

B Series Gear Units

OIBCE 0501-1112

Operating Instructions



Contents.....	01
1 - How to Use This Manual	05
2 - Unit Designation.....	06
2.1- Detailed Unit Designation	06
2.2- Nameplate, Unit Designation	07
3. Standard Type Gearbox Parts Lists	08
3.1- BT..3.00 type.....	08
3.2- BT..3.0S type	09
3.3- BT..3.01 type.....	10
3.4- BT..3.02 type.....	11
3.5- BT..3.03 type.....	12
3.6- BT..3.04 type.....	13
3.7- BT..3.05 type.....	14
3.8- BT..3.08 type.....	15
3.9- BT..4.00 type.....	16
3.10- BT..4.0S type	17
3.11- BT..4.01 type.....	18
3.12- BT..4.02 type.....	19
3.13- BT..4.03 type.....	20
3.14- BT..4.04 type.....	21
3.15- BT..4.05 type.....	22
3.16- BT..4.08 type.....	23
4- Safety	24
4.1- Intended use.....	24
4.2- Improper use	24
4.3- Safety Instructions.....	25
4.3.1- General safety instructions.....	25
4.3.1.1- Working on the gearbox	25
4.3.1.2- Operation	25
4.3.1.3- Maintenance	25
4.3.1.4- Lubrication.....	25
4.3.1.5- Working conditions	25
4.4- Tightening torques.....	26
4.5- Case of fire	26
4.5.1- Suitable extinguishers.....	26
4.5.2- Unsuitable extinguishers.....	26
5 - Checking Before Installing the Gearbox.....	27
5.1- Transportation	27
5.2- Storage.....	28



6- Installing the Gearbox	28
6.1- Before you start	28
6.2- Checking shaft dimensions	29
6.3- Checking ambient temperatures	29
6.4- Checking voltage supply	29
6.5- Checking mounting position	32
6.6- How to use breather plug	32
6.7- Checking oil level	32
6.8- Checking shaft ends and mounting faces	32
6.9- Protection from corrosive environment.....	32
6.10- Checking accessibility to oil plugs	33
7- Mechanical Installation	33
7.1- Installing customer shaft with shoulder	34
7.2- Disassembling customer shaft with shoulder	35
7.3- Installing output shaft elements	37
7.4- Correct position of output shaft elements.....	37
7.5- Coupling connection.....	38
7.6- Shaft tightening torques	39
7.7- Recommended shaft dimensions for B.00 types.....	40
8- Maintenance & Inspection	41
9- Lubrication.....	42
9.1- Oil types	42
9.2- Changing the oil	43
9.3- Oil quantities (lt)	43
9.4- Oil plugs	44
9.5- Mounting Positions	46
10- Cooling Options	47
10.1- Fan cooling.....	48
10.2- Cooling with cooling coil	48
10.3- Cooling with water / oil heat exchanger.....	49
10.4- Cooling with air / oil heat exchanger	50



11- Troubleshooting Guide.....	51
12- Disposal.....	54
12.1- Disposal of oil.....	54
12.2- Disposal of sealing.....	54
12.3- Disposal of metal parts.....	54
13- Appendix.....	55
13.1- Warranty conditions.....	56
13.2- Warranty paper.....	57
13.3- Service points.....	58



1 - How to Use This Manual

Take attention to the following safety and warning signs for proper understanding and quick reference.



Electrical Hazard; Can cause severe or fatal injuries.



Mechanical Hazard; Can cause severe or fatal injuries.



Likely to be Hazardous; Can cause minor or fatal injuries



Damage Risk; Can damage the gearbox or environment



Important Information



EC Machinery Directive:

Within terms of the EC machinery directive 2006/42/EC ,the gear reducer is not considered an autonomous machine, but as a component to install in machines. Operation is prohibited within the area of validity of the EC directive, until it has been determined that the machine, in which this product is installed, corresponds to the regulations within this directive.

The operating instructions contain important information to ensure;

- Trouble-free operation
- Fulfilment of any rights to claim under guarantee

The operating instruction must be kept close to the gearbox and must be available in case it is needed.

This operating instruction is written for B series gear units and is applicable only for B series. If any different type of gearbox is used please ask YILMAZ REDUKTOR for the operating instructions of that type.

This instruction can be used only for standard type geared units of YILMAZ REDUKTOR. For special application and modified gear units ask YILMAZ REDUKTOR for validity.

This manual does not cover 94/9/EC compatible gearboxes. For 94/9/EC contact YILMAZ REDUKTOR.



2 - Unit Designation

2.1- Detailed Unit Designation



Detailed B series gear units designation for ordering

(This Designation is different from the short nameplate designation)

B T 05 2 3 . 0 1 R - M1

Mounting Position

M1: Output shaft is parallel to earth, cover is on top

M2: Gearbox is upright and output shaft is over input shaft

M3: Output shaft is parallel to earth, cover is on bottom

M4: Gearbox is upright and output shaft is under input shaft

M5: Output shaft is vertical to earth and output shaft points to earth

M6: Output shaft is vertical to earth and output shaft points to sky

AX: Gearbox works in an angle

...T: with torque arm

Shaft and Flange Arrangement

Please refer to shaft and flange arrangements section at catalogue

Output Shaft Properties

0: Hollow shaft

1: Solid output shaft

2: Solid output shaft and output flange

3: Hollow shaft and output flange

4: Double output shaft

5: Double output shaft and flange

8: Hollow output shaft and double output flange

S: Hollow shaft with shrink disk

E: Extruder type output

Input Shaft Properties

0: Standard input shaft

F: With brake

K: With backstop

Number of Gear Stages

2: Two stages

3: Three stages

4: Four stages

Revision Number

Second revision

Gearbox Size

Sizes from 03.....to 15

Version of Gearbox

T: Free solid input shaft

Series of Gear Unit

B: Helical gear type horizontal industrial gear units with bevel stage input





2.2- Nameplate, unit designation



Nameplate unit designation is a short abbreviation from the detailed designation

A sample name plate for B Series

	YILMAZ REDÜKTÖR www.yr.com.tr MADE IN TURKEY	
Type:	BT0323.00R	
Serial N.:	100896546	
Power:	45 kW	Ratio: 7.55
Speed:	185 rpm.	M.Pos.: M1
Oil:	MINERAL VG460	
Oil Qty:	21	lt.

Abbreviations:

Serial N. : Serial Number
M.Pos. : Mounting Position

Type Designation;

BT0323.00 R
Type Shaft and Flange Arrangement

Serial Number: 100896546

Viewed from input side

L - Right input, Left output
R - Left input, Right output
U - Right input, Right output
V - Left input, Left output



3. Standard Type Gearbox Part List
3.1- BT...3.00 types

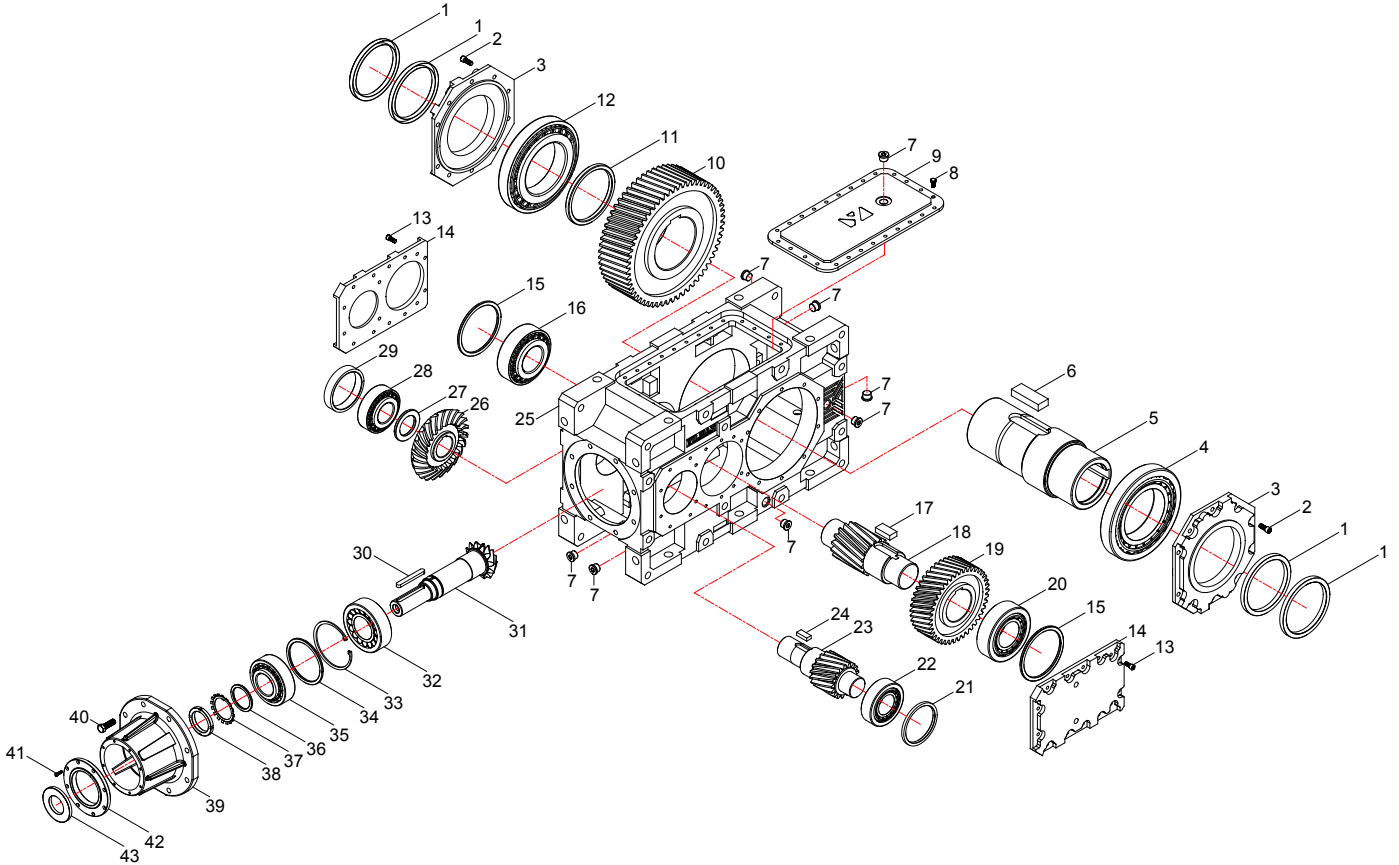

Standard BT...3.00 type basic part diagram. Parts may differ for special applications.



Standard Part List

1- Seal	10- Gear	19- Gear	28- Bearing	37- Locking Plate
2- Bolt	11- Spacer	20- Bearing	29- Spacer	38- Locking Nut
3- Sealed Side Cover	12- Bearing	21- Spacer	30- Key	39- Input Bearing Hosing
4- Bearing	13- Bolt	22- Bearing	31- Gear	40- Bolt
5- Hollow Output Shaft	14- Cover	23- Gear	32- Bearing	41- Bolt
6- Key	15- Spacer	24- Key	33- Circlips	42- Sealed Side Cover
7- Oil Plug	16- Bearing	25- Housing	34- Spacer	43- Seal
8- Bolt	17- Key	26- Gear	35- Bearing	
9- Top Cover Plate	18- Gear	27- Spacer	36- Spacer	



3.2- BT...3.0S Types

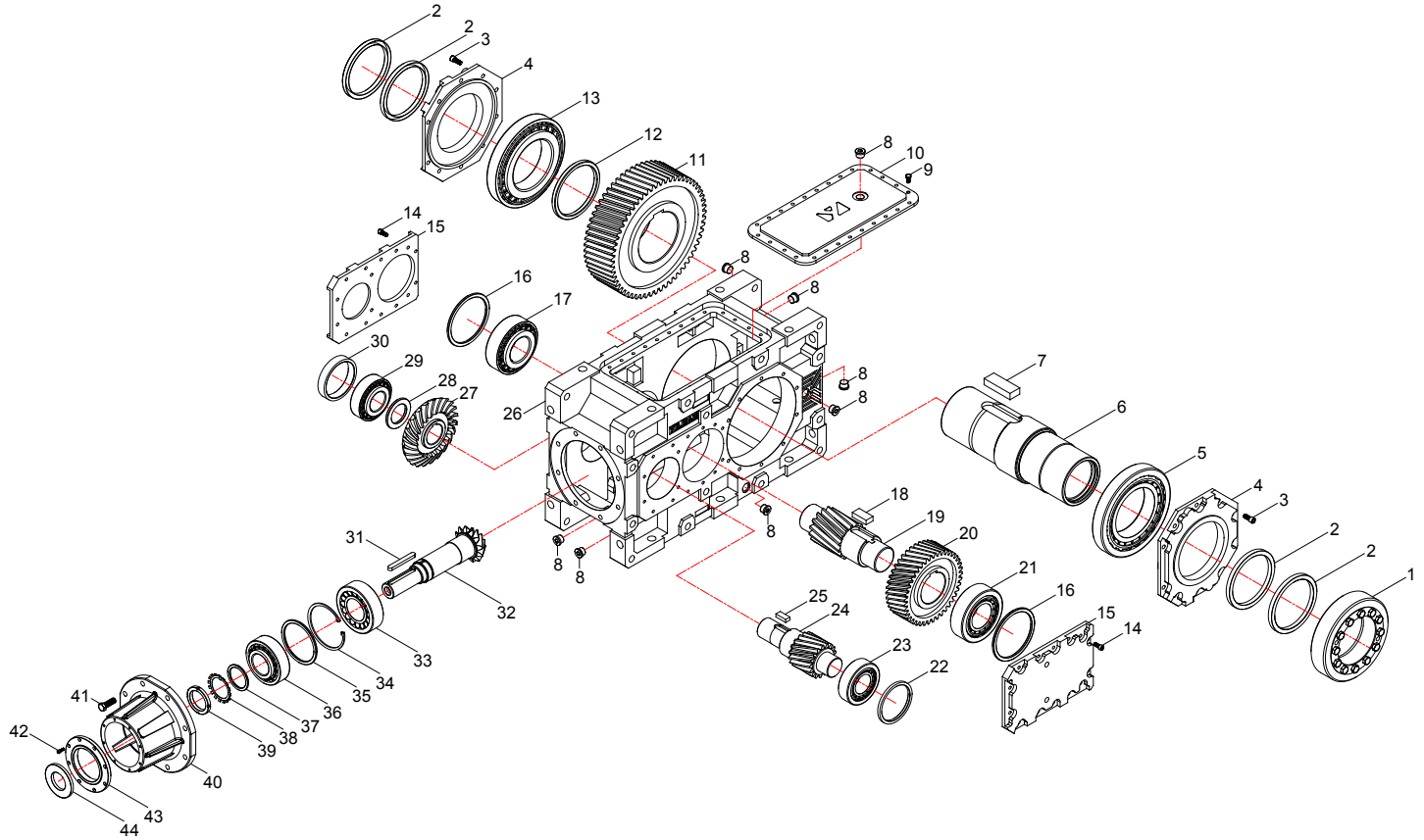

Standard BT...3.0S type basic part diagram. Parts may differ for special applications.

Standard Part List

1- Shrink Disk	10- Top Cover Plate	19- Gear	28- Spacer	37- Spacer
2- Seal	11- Gear	20- Gear	29- Bearing	38- Locking Plate
3- Bolt	12- Spacer	21- Bearing	30- Spacer	39- Locking Nut
4- Sealed Side Cover	13- Bearing	22- Spacer	31- Key	40- Input Bearing Housing
5- Bearing	14- Bolt	23- Bearing	32- Gear	41- Bolt
6- Hollow Output Shaft	15- Cover	24- Gear	33- Bearing	42- Bolt
7- Key	16- Spacer	25- Key	34- Circlips	43- Sealed Side Cover
8- Oil Plug	17- Bearing	26- Housing	35- Spacer	44- Seal
9- Bolt	18- Key	27- Gear	36- Bearing	



3.3- BT...3.01 Types

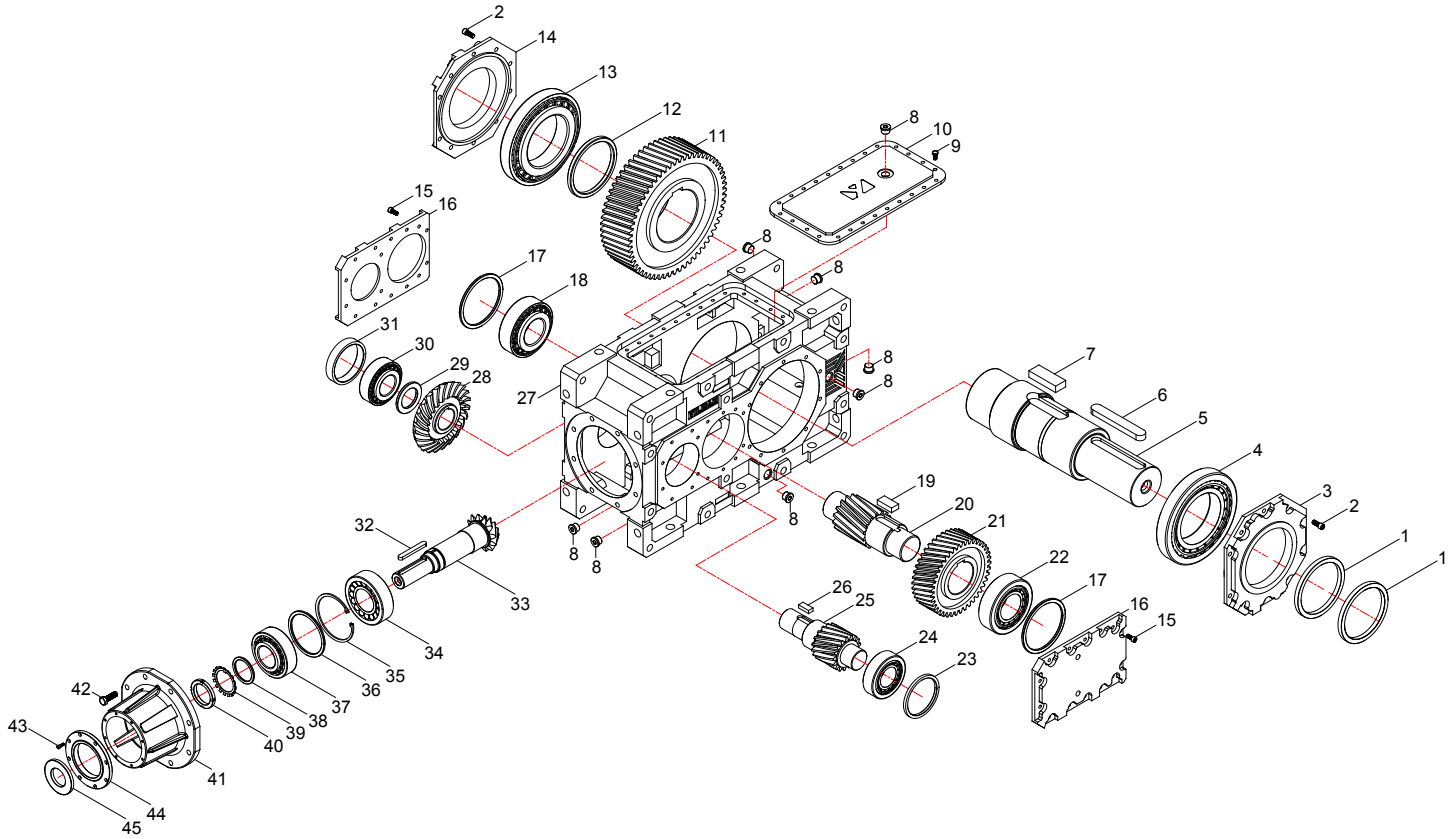

Standard BT...3.01 type basic part diagram. Parts may differ for special applications.

Standard Part List

1- Seal	10- Top Cover Plate	19- Key	28- Gear	37- Bearing
2- Bolt	11- Gear	20- Gear	29- Spacer	38- Spacer
3- Sealed Side Cover	12- Spacer	21- Gear	30- Bearing	39- Locking Plate
4- Bearing	13- Bearing	22- Bearing	31- Spacer	40- Locking Nut
5- Output Shaft	14- Cover	23- Spacer	32- Key	41- Input Bearing Housing
6- Key	15- Bolt	24- Bearing	33- Gear	42- Bolt
7- Key	16- Cover	25- Gear	34- Bearing	43- Bolt
8- Oil Plug	17- Spacer	26- Key	35- Circlips	44- Sealed Side Cover
9- Bolt	18- Bearing	27- Housing	36- Spacer	45- Seal



3.4- BT...3.02 Types

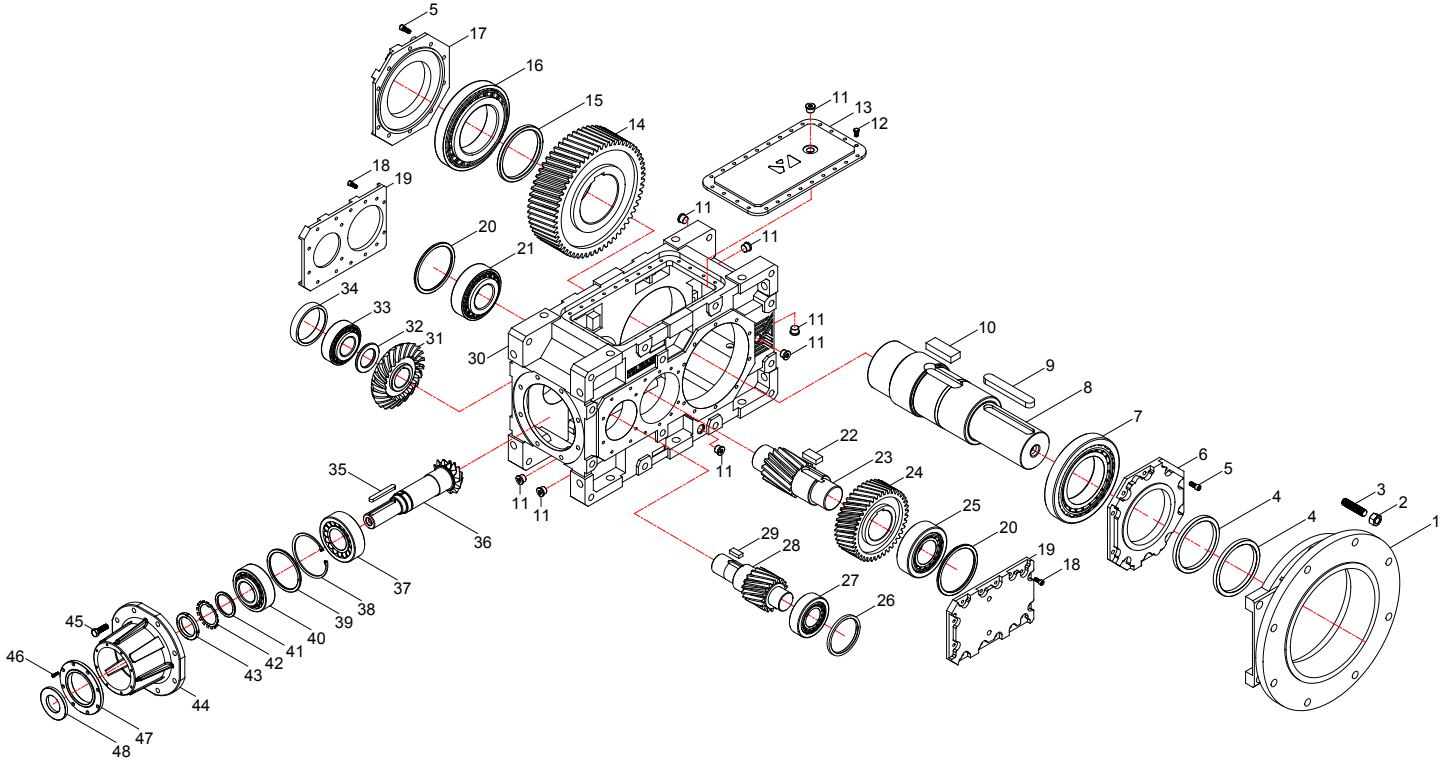

Standard BT...3.02 type basic part diagram. Parts may differ for special applications.

Standard Part List

1- Output Flange	11- Oil Plug	21- Bearing	31- Gear	41- Spacer
2- Nut	12- Bolt	22- Key	32- Spacer	42- Locking Plate
3- Screw Pin	13- Top Cover Plate	23- Gear	33- Bearing	43- Locking Nut
4- Seal	14- Gear	24- Gear	34- Spacer	44- Input Bearing Housing
5- Bolt	15- Spacer	25- Bearing	35- Key	45- Bolt
6- Sealed Side Cover	16- Bearing	26- Spacer	36- Gear	46- Bolt
7- Bearing	17- Cover	27- Bearing	37- Bearing	47- Sealed Side Cover
8- Output Shaft	18- Bolt	28- Gear	38- Circlips	48- Seal
9- Key	19- Cover	29- Key	39- Spacer	
10- Key	20- Spacer	30- Housing	40- Bearing	



3.5- BT...3.03 Types

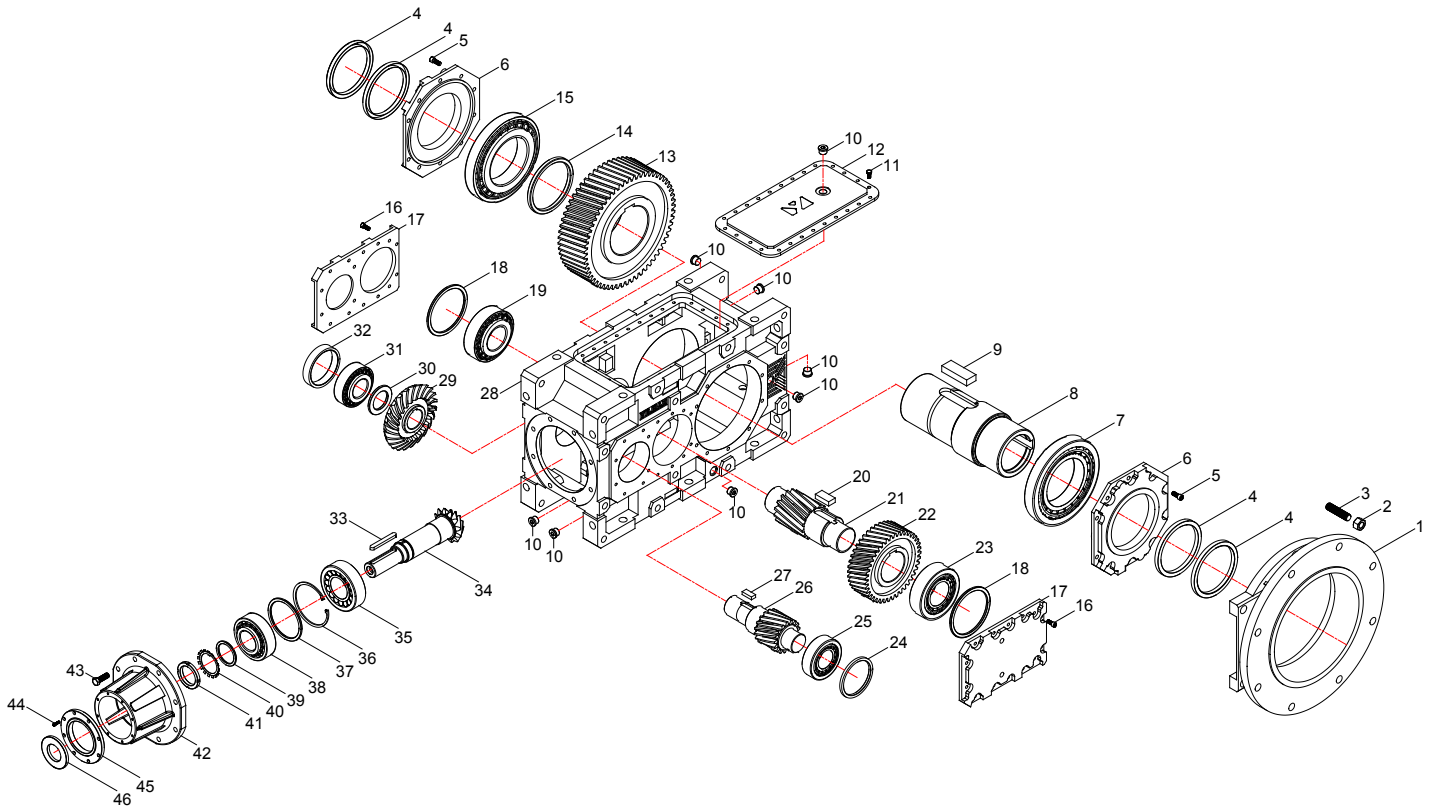

Standard BT...3.03 type basic part diagram. Parts may differ for special applications.



Standard Part List

1- Output Flange	11- Bolt	21 - Gear	31- Bearing	41- Locking Nut
2- Nut	12- Top Cover Plate	22- Gear	32- Spacer	42- Input Bearing Housing
3- Screw Pin	13- Gear	23- Bearing	33- Key	43- Bolt
4- Seal	14- Spacer	24- Spacer	34- Gear	44- Bolt
5- Bolt	15- Bearing	25- Bearing	35- Bearing	45- Sealed Side Cover
6- Sealed Side Cover	16- Bolt	26- Gear	36- Circlips	46- Seal
7- Bearing	17- Cover	27- Key	37- Spacer	
8- Hollow Output Shaft	18- Spacer	28- Housing	38- Bearing	
9- Key	19- Bearing	29- Gear	39- Spacer	
10- Oil Plug	20- Key	30- Spacer	40- Locking Plate	



3.6- BT...3.04 Types

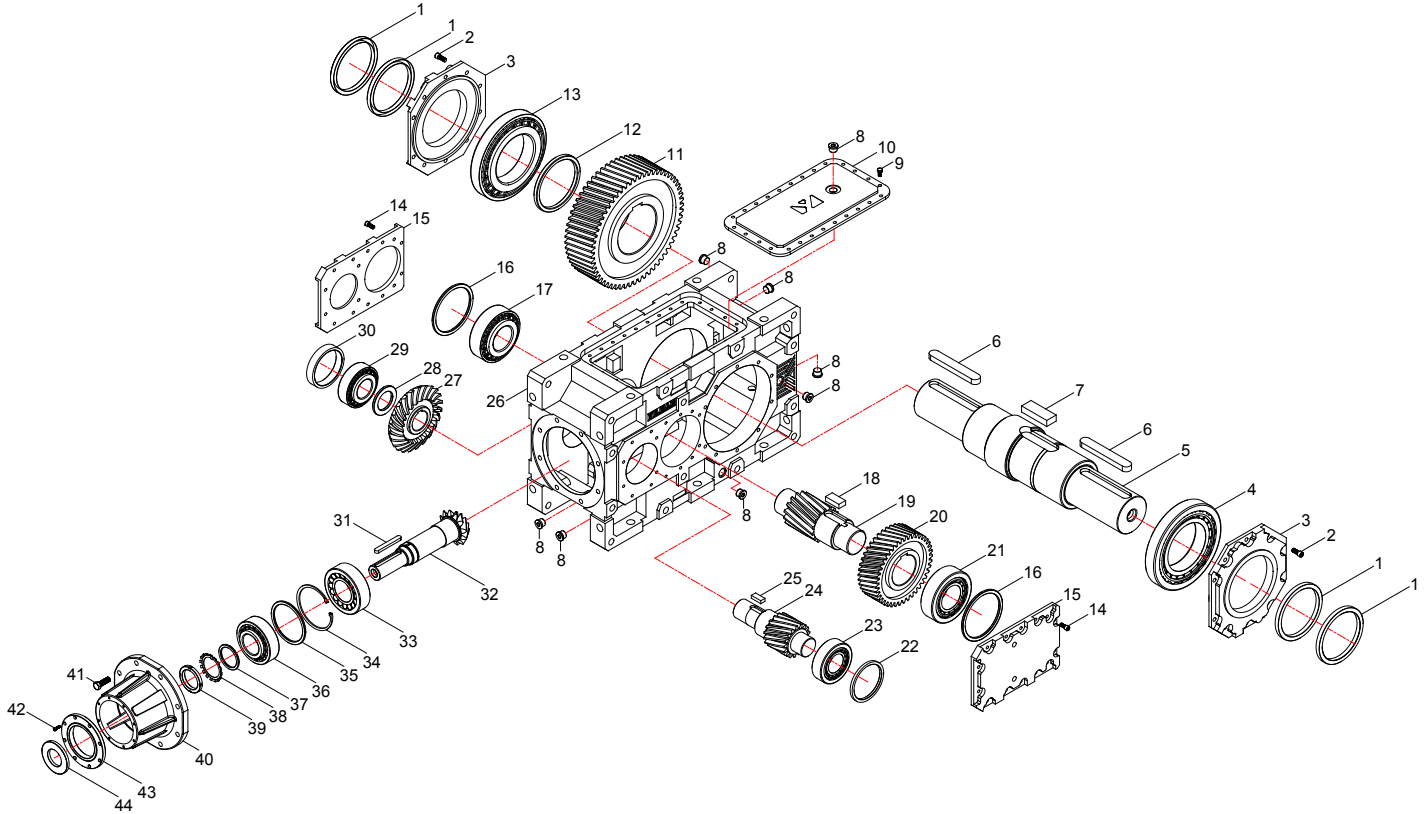

Standard BT...3.04 type basic part diagram. Parts may differ for special applications.

Standard Part List

1- Seal	10- Top Cover Plate	19- Gear	28- Spacer	37- Spacer
2- Bolt	11- Gear	20- Gear	29- Bearing	38- Locking Plate
3- Sealed Side Cover	12- Spacer	21- Bearing	30- Spacer	39- Locking Nut
4- Bearing	13- Bearing	22- Spacer	31- Key	40- Input Bearing Housing
5- Output Shaft	14- Bolt	23- Bearing	32- Gear	41- Bolt
6- Key	15- Cover	24- Gear	33- Bearing	42- Bolt
7- Key	16- Spacer	25- Key	34- Circlips	43- Sealed Side Cover
8- Oil Plug	17- Bearing	26- Housing	35- Spacer	44- Seal
9- Bolt	18- Key	27- Gear	36- Bearing	



3.7- BT...3.05 Types

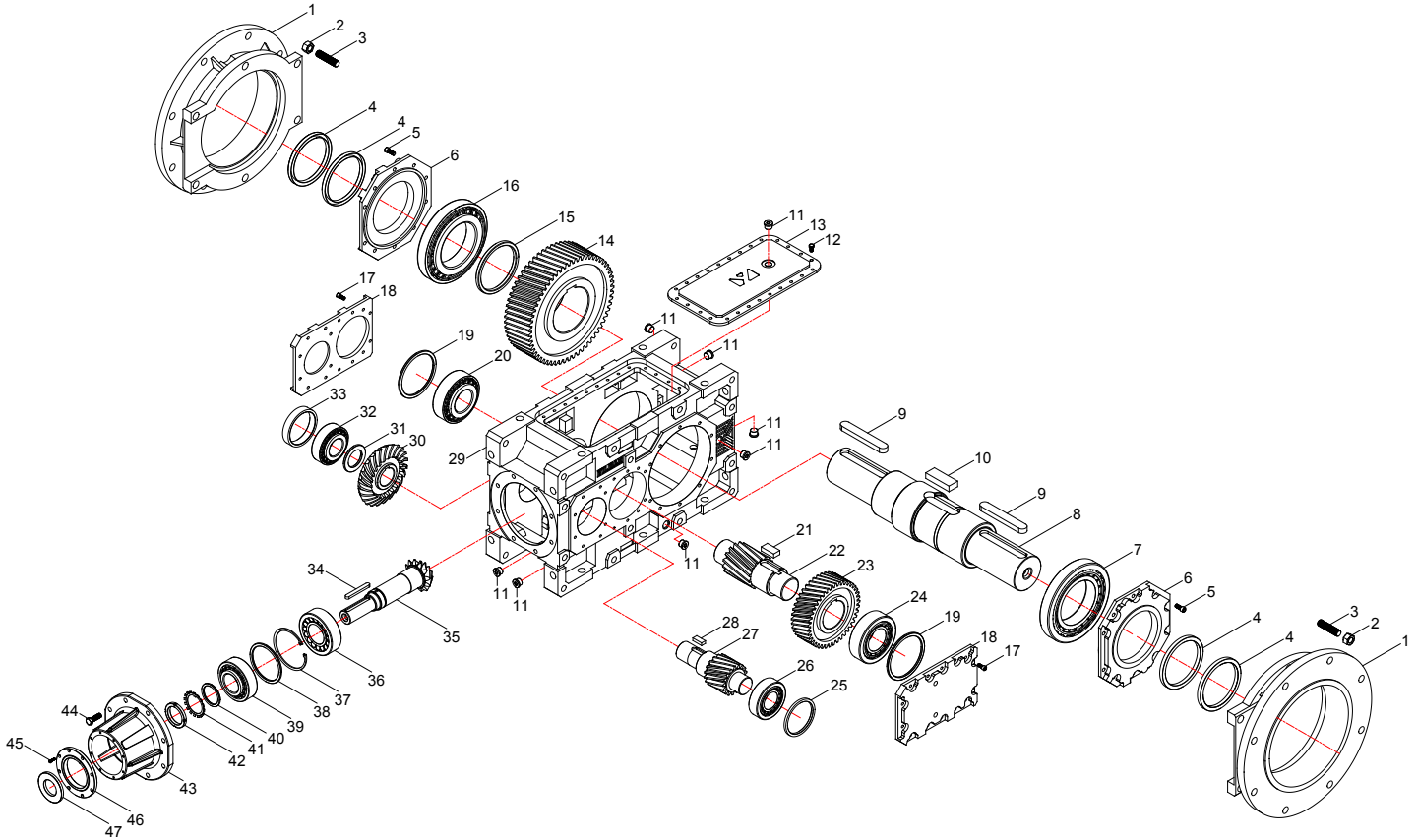

Standard BT...3.05 type basic part diagram. Parts may differ for special applications.

Standard Part List

1- Output Flange	11- Oil Plug	21- Key	31- Spacer	41- Locking Plate
2- Nut	12- Bolt	22- Gear	32- Bearing	42- Locking Nut
3- Screw Pin	13- Top Cover Plate	23- Gear	33- Spacer	43- Input Bearing Housing
4- Seal	14- Gear	24- Bearing	34- Key	44- Bolt
5- Bolt	15- Spacer	25- Spacer	35- Gear	45- Bolt
6- Sealed Side Cover	16- Bearing	26- Bearing	36- Bearing	46- Sealed Side Cover
7- Bearing	17- Bolt	27- Gear	37- Circlips	47- Seal
8- Output Shaft	18- Cover	28- Key	38- Spacer	
9- Key	19- Spacer	29- Housing	39- Bearing	
10- Key	20- Bearing	30- Gear	40- Spacer	



3.8- BT...3.08 Types

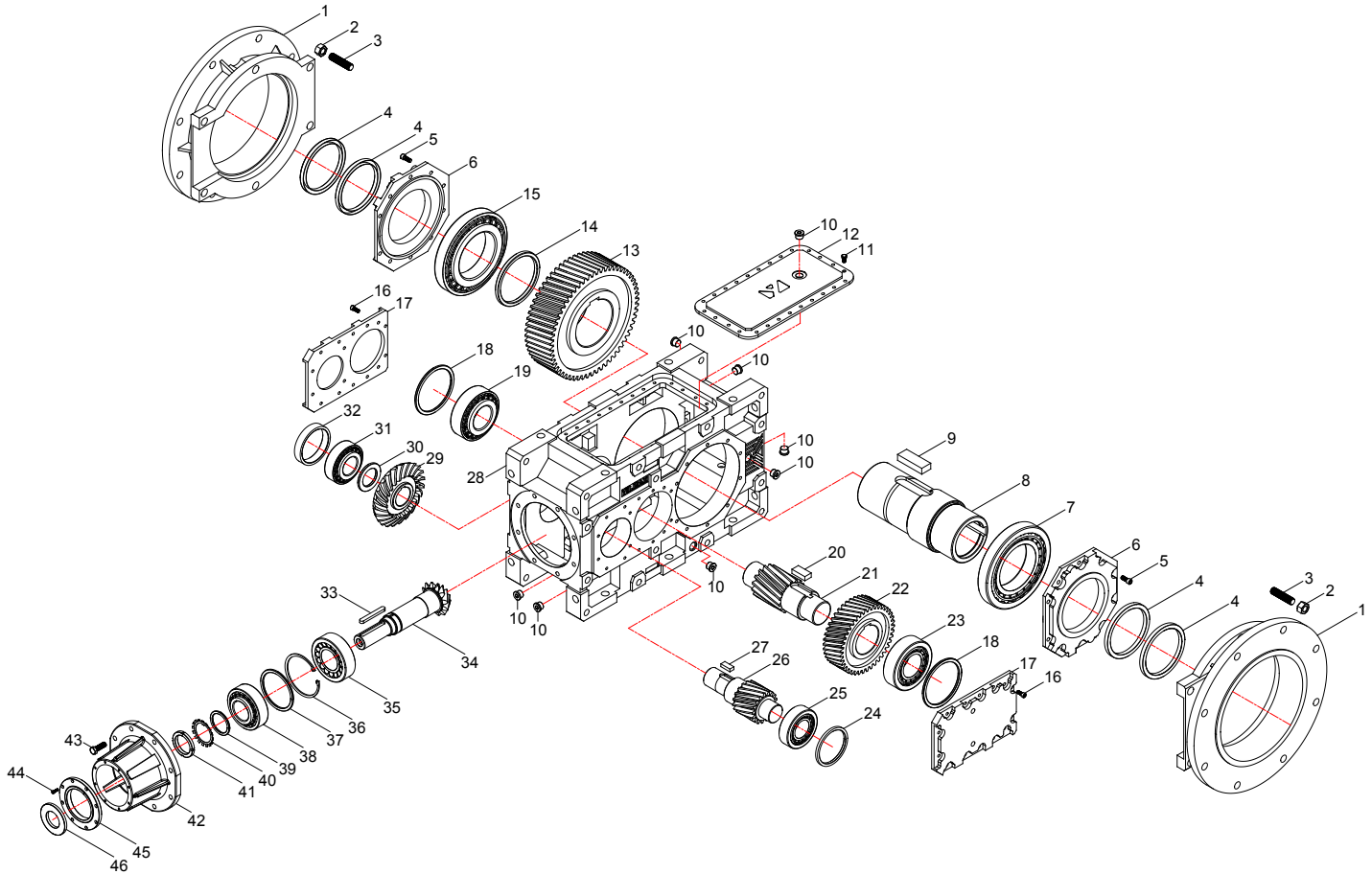

Standard BT...3.08 type basic part diagram. Parts may differ for special applications.



Standard Part List

1- Output Flange	11- Bolt	21 - Gear	31- Bearing	41- Locking Nut
2- Nut	12- Top Cover Plate	22- Gear	32- Spacer	42- Input Bearing Housing
3- Screw Pin	13- Gear	23- Bearing	33- Key	43- Bolt
4- Seal	14- Spacer	24- Spacer	34- Gear	44- Bolt
5- Bolt	15- Bearing	25- Bearing	35- Bearing	45- Sealed Side Cover
6- Sealed Side COver	16- Bolt	26- Gear	36- Circlips	46- Seal
7- Bearing	17- Cover	27- Key	37- Spacer	
8- Hollow Output Shaft	18- Spacer	28- Housing	38- Bearing	
9- Key	19- Bearing	29- Gear	39- Spacer	
10- Oil Plug	20- Key	30- Spacer	40- Locking Plate	



3.9- BT...4.00 Types

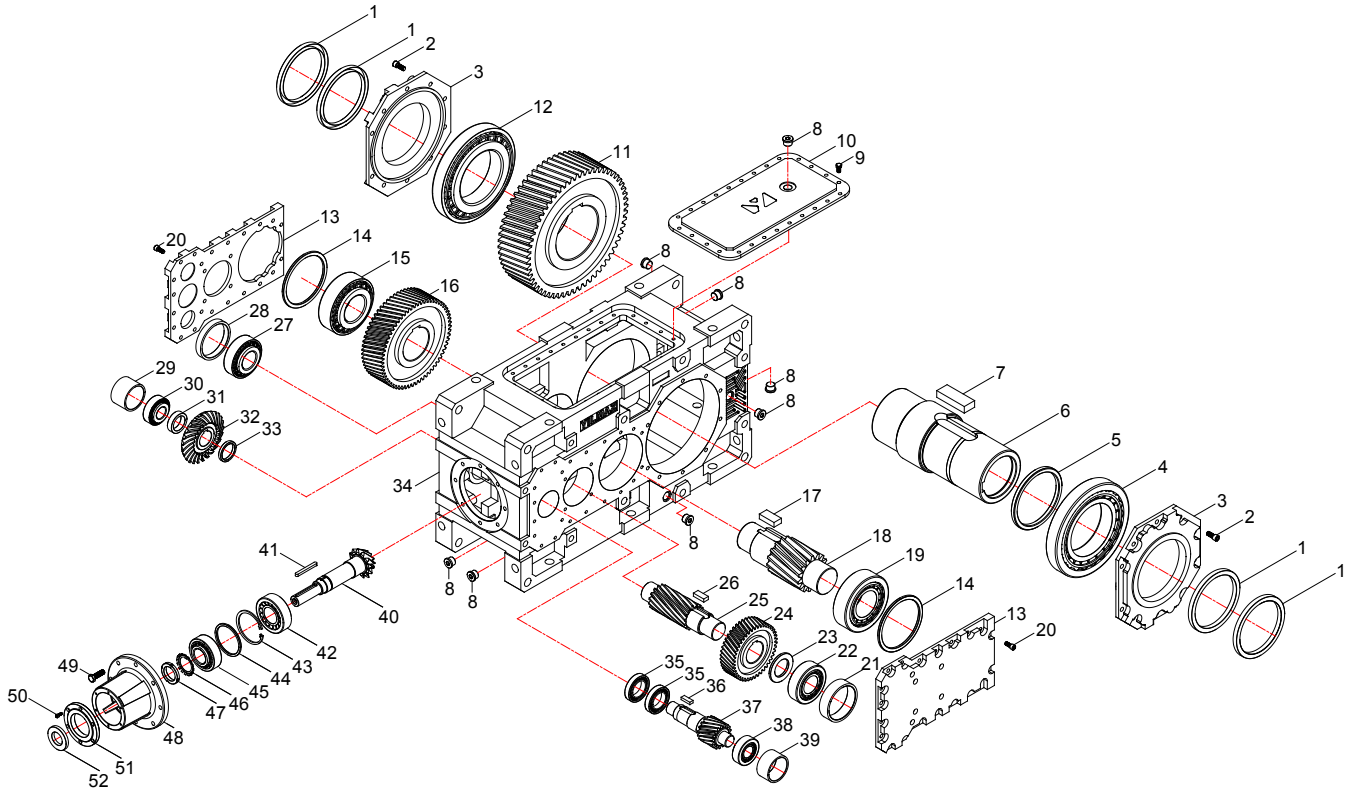

Standard BT...4.00 type basic part diagram. Parts may differ for special applications.

Standard Part List

1- Seal	12- Bearing	23- Spacer	34- Housing	45- Bearing
2- Bolt	13- Cover	24- Gear	35- Bearing	46- Locking Plate
3- Sealed Side Cover	14- Spacer	25- Gear	36- Key	47- Locking Nut
4- Bearing	15- Bearing	26- Key	37- Gear	48- Input Bearing Housing
5- Spacer	16- Gear	27- Bearing	38- Bearing	49- Bolt
6- Hollow Output Shaft	17- Key	28- Spacer	39- Spacer	50- Bolt
7- Key	18- Gear	29- Spacer	40- Gear	51- Sealed Side Cover
8- Oil Plug	19- Bearing	30- Bearing	41- Key	52- Seal
9- Screw Pin	20- Bolt	31- Spacer	42- Bearing	
10- Top Cover Plate	21- Spacer	32- Gear	43- Circlips	
11- Gear	22- Bearing	33- Spacer	44- Spacer	



3.10- BT...4.0S Types

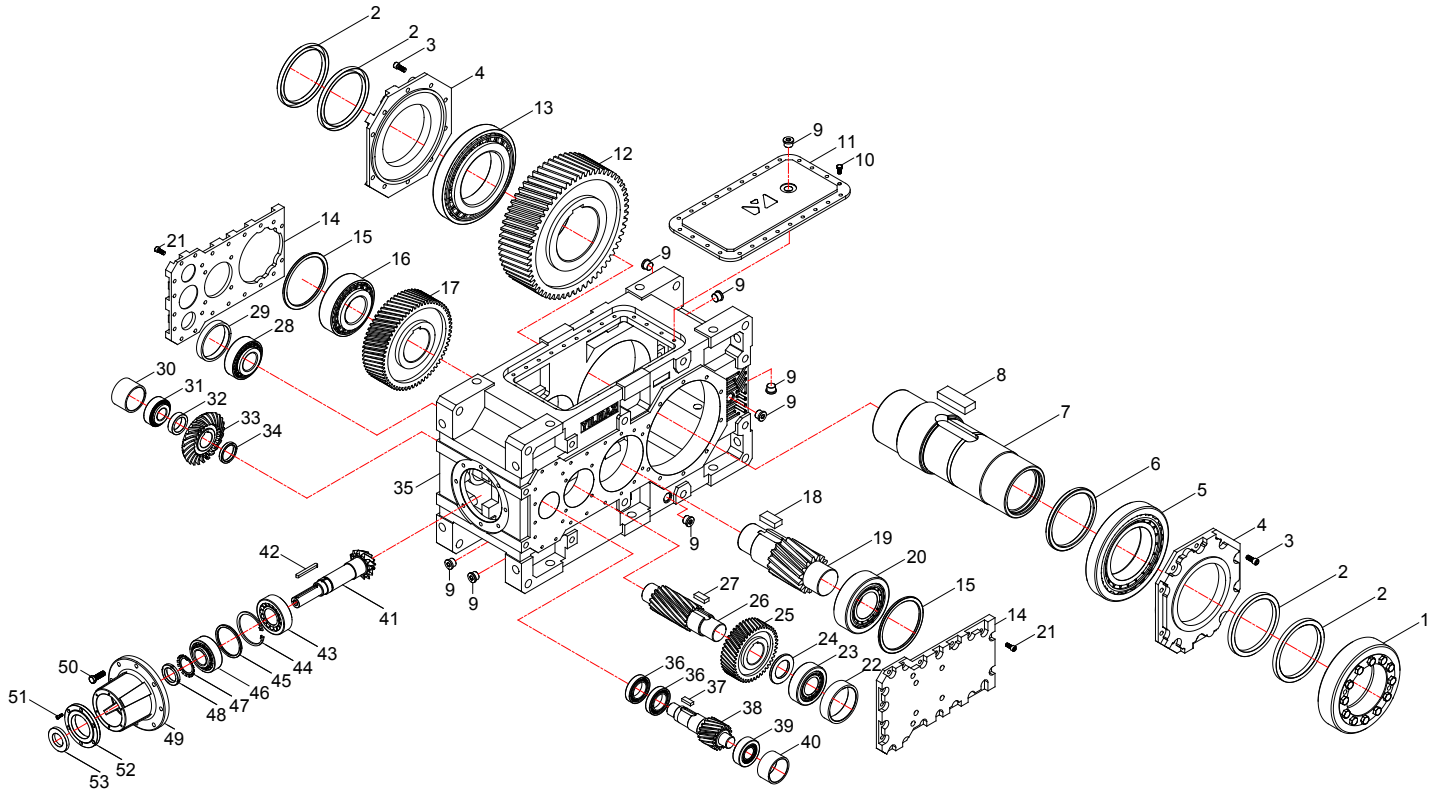

Standard BT...4.0S type basic part diagram. Parts may differ for special applications.

Standard Part List

1- Shrink Disk	12- Gear	23- Bearing	34- Spacer	45- Spacer
2- Seal	13- Bearing	24- Spacer	35- Housing	46- Bearing
3- Bolt	14- Cover	25- Gear	36- Bearing	47- Locking Plate
4- Sealed Side Cover	15- Spacer	26- Gear	37- Key	48- Locking Nut
5- Bearing	16- Bearing	27- Key	38- Gear	49- Input Bearing Housing
6- Spacer	17- Gear	28- Bearing	39- Bearing	50- Bolt
7- Hollow Output Shaft	18- Key	29- Spacer	40- Spacer	51- Bolt
8- Key	19- Gear	30- Spacer	41- Gear	52- Sealed Side Cover
9- Oil Plug	20- Bearing	31- Bearing	42- Key	53- Seal
10- Bolt	21- Bolt	32- Spacer	43- Bearing	
11- Top Cover Plate	22- Spacer	33- Gear	44- Circlips	



3.11- BT...4.01 Types

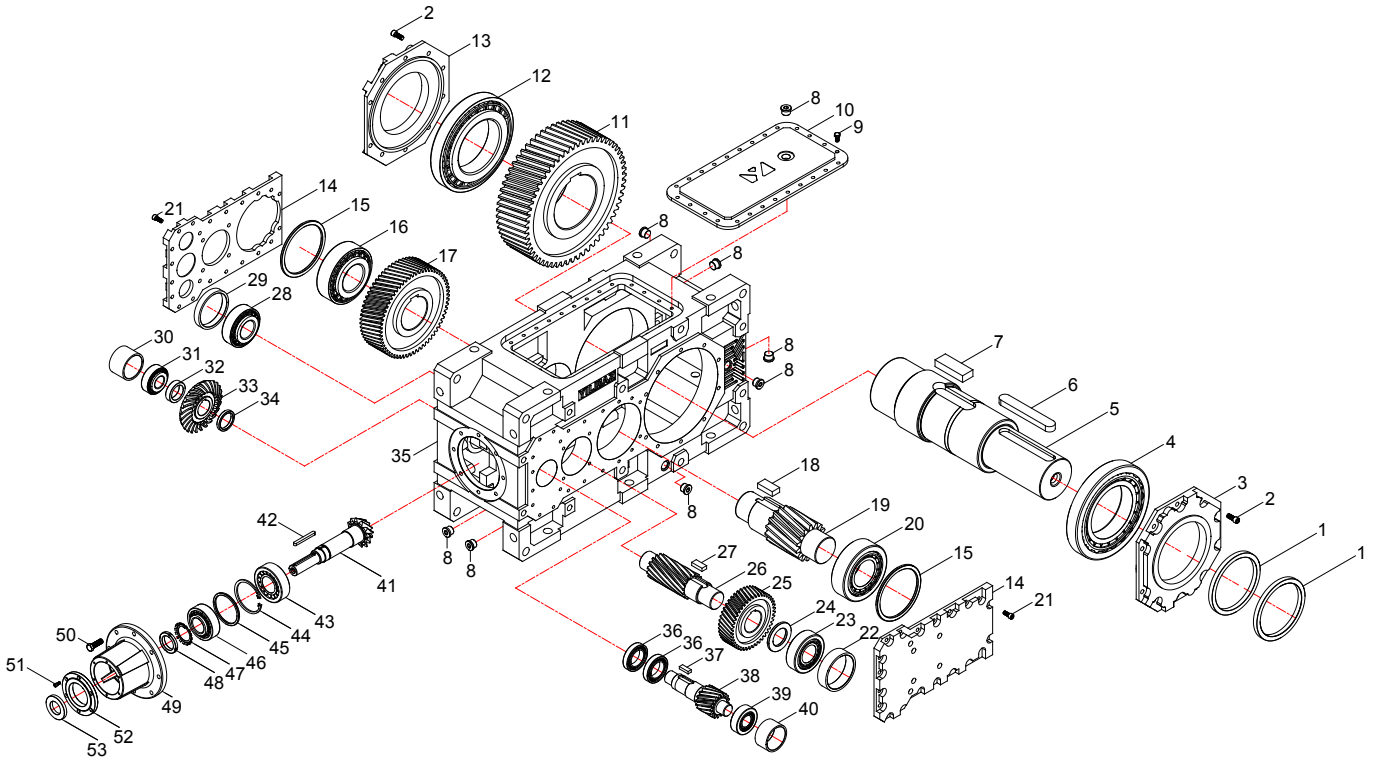

Standard BT...4.01 type basic part diagram. Parts may differ for special applications.

Standard Part List

1- Seal	12- Bearing	23- Bearing	34- Spacer	45- Spacer
2- Bolt	13- Cover	24- Spacer	35- Housing	46- Bearing
3- Sealed Side Cover	14- Cover	25- Gear	36- Bearing	47- Locking Plate
4- Bearing	15- Spacer	26- Gear	37- Key	48- Locking Nut
5- Output Shaft	16- Bearing	27- Key	38- Gear	49- Input Bearing Housing
6- Key	17- Gear	28- Bearing	39- Bearing	50- Bolt
7- Key	18- Key	29- Spacer	40- Spacer	51- Bolt
8- Oil Plug	19- Gear	30- Spacer	41- Gear	52- Sealed Side Cover
9- Bolt	20- Bearing	31- Bearing	42- Key	53- Seal
10- Top Side Cover	21- Bolt	32- Spacer	43- Bearing	
11- Gear	22- Spacer	33- Gear	44- Circlips	



3.12- BT...4.02 Types

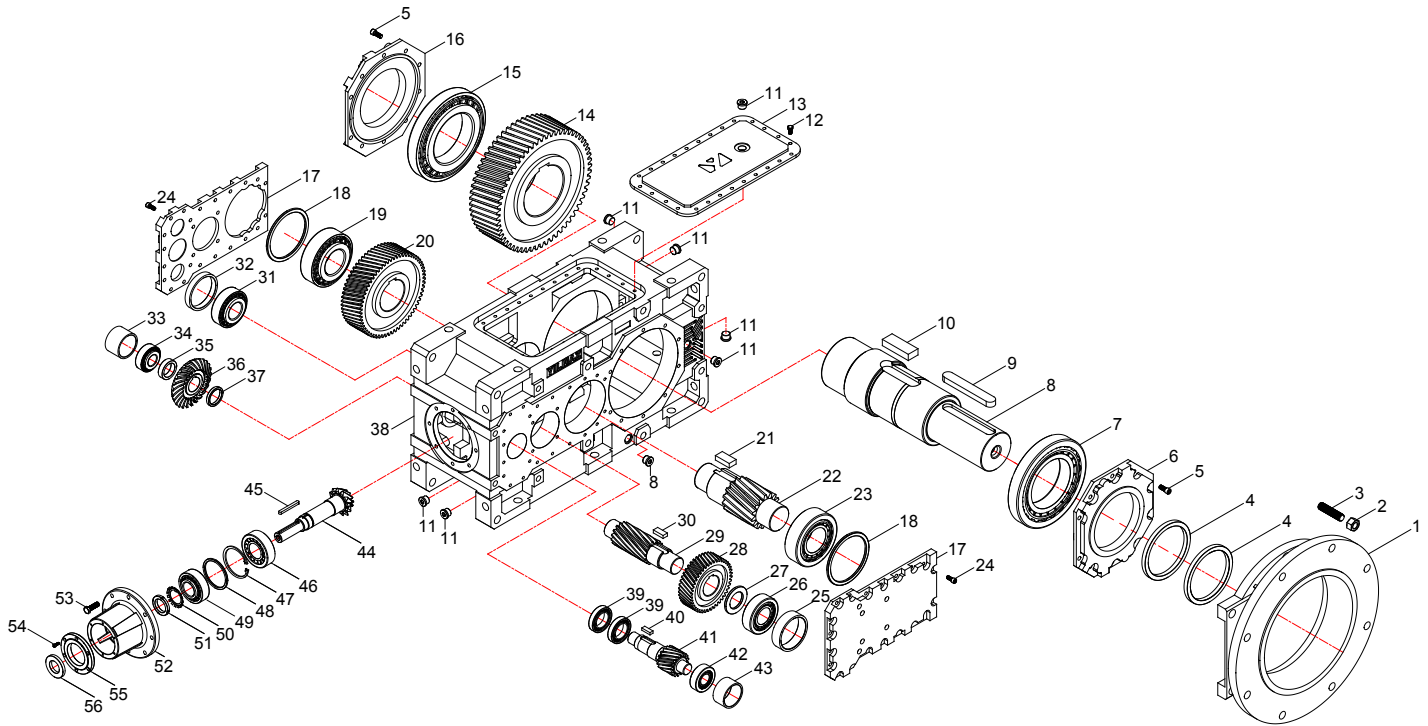

Standard BT...4.02 type basic part diagram. Parts may differ for special applications.

Standard Part List

1- Output Flange	12- Bolt	23- Bearing	34- Bearing	45- Key	56- Seal
2- Nut	13- Top Side Cover	24- Bolt	35- Spacer	46- Bearing	
3- Screw Pin	14- Gear	25- Spacer	36- Gear	47- Circlips	
4- Seal	15- Bearing	26- Bearing	37- Spacer	48- Spacer	
5- Bolt	16- Cover	27- Spacer	38- Housing	49- Bearing	
6- Sealed Side Cover	17- Cover	28- Gear	39- Bearing	50- Locking Plate	
7- Bearing	18- Spacer	29- Gear	40- Key	51- Locking Nut	
8- Output Shaft	19- Bearing	30- Key	41- Gear	52- Input Bearing Housing	
9- Key	20- Gear	31- Bearing	42- Bearing	53- Bolt	
10- Key	21- Key	32- Spacer	43- Spacer	54- Bolt	
11- Oil Plug	22- Gear	33- Spacer	44- Gear	55- Sealed Side Cover	



3.13- BT...4.03 Types

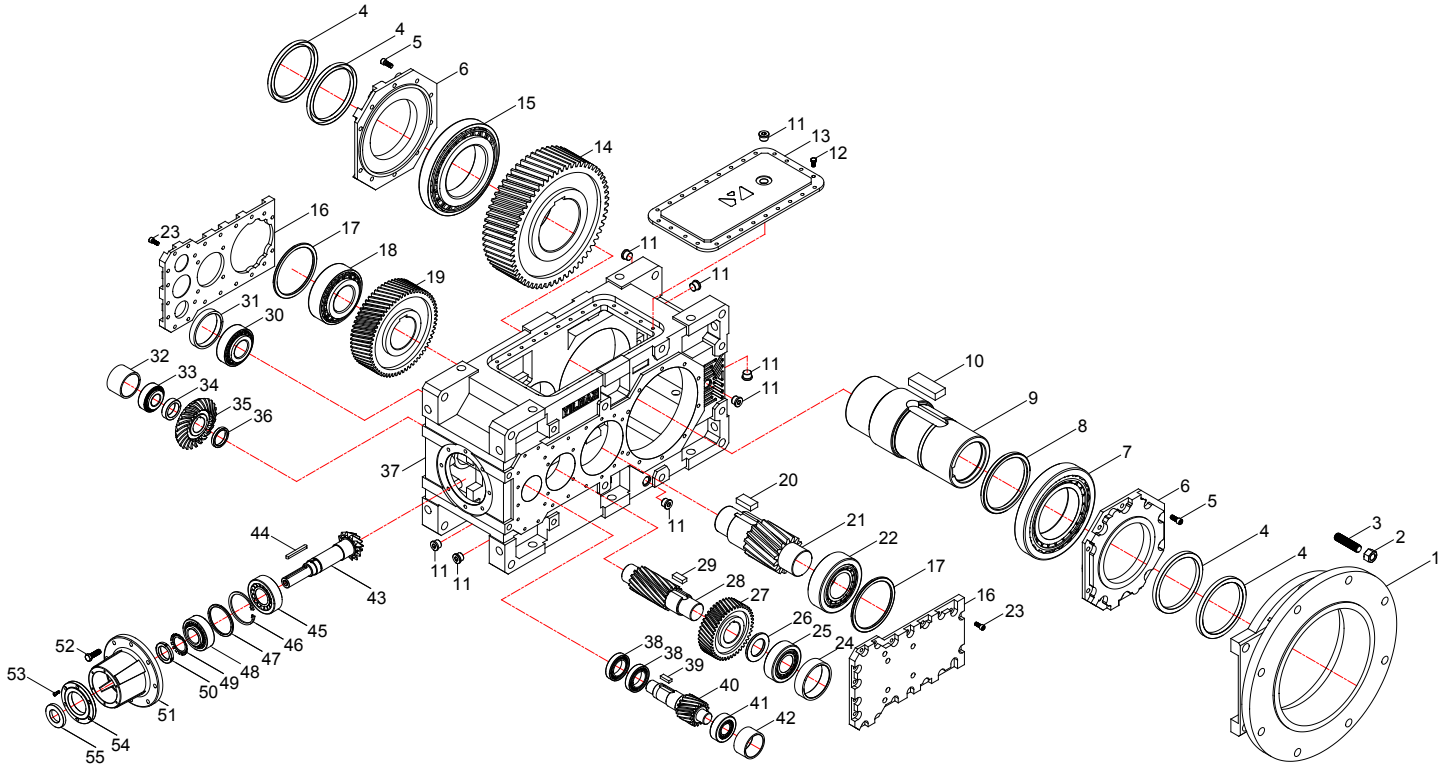

Standard BT...4.03 type basic part diagram. Parts may differ for special applications.

Standard Part List

1- Output Flange	12- Bolt	23- Bolt	34- Spacer	45- Bearing
2- Nut	13- Top Side Cover	24- Spacer	35- Gear	46- Circlips
3- Screw Pin	14- Gear	25- Bearing	36- Spacer	47- Spacer
4- Seal	15- Bearing	26- Spacer	37- Housing	48- Bearing
5- Bolt	16- Cover	27- Gear	38- Bearing	49- Locking Plate
6- Sealed Side Cover	17- Spacer	28- Gear	39- Key	50- Locking Nut
7- Bearing	18- Bearing	29- Key	40- Gear	51- Input Bearing Housing
8- Spacer	19- Gear	30- Bearing	41- Bearing	52- Bolt
9- Hollow Output Shaft	20- Key	31- Spacer	42- Spacer	53- Bolt
10- Key	21- Gear	32- Spacer	43- Gear	54- Sealed Side Cover
11- Oil Plug	22- Bearing	33- Bearing	44- Key	55- Seal



3.14- BT...4.04 Types

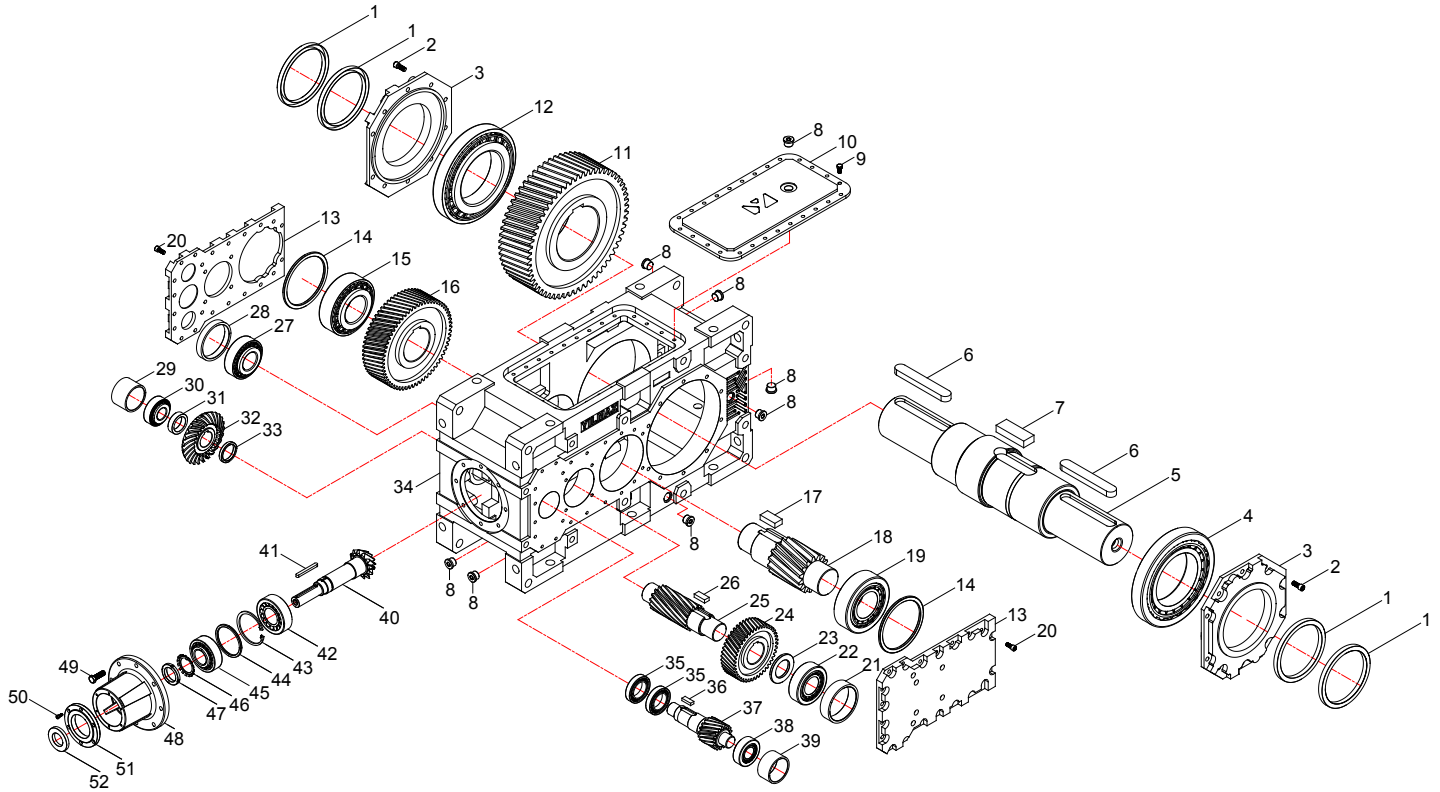

Standard BT...4.04 type basic part diagram. Parts may differ for special applications.

Standard Part List

1- Seal	12- Bearing	23- Spacer	34- Housing	45- Bearing
2- Bolt	13- Cover	24- Gear	35- Bearing	46- Locking Plate
3- Sealed Side Cover	14- Spacer	25- Gear	36- Key	47- Locking Nut
4- Bearing	15- Bearing	26- Key	37- Gear	48- Input Bearing Housing
5- Output Shaft	16- Gear	27- Bearing	38- Bearing	49- Bolt
6- Key	17- Key	28- Spacer	39- Spacer	50- Bolt
7- Key	18- Gear	29- Spacer	40- Gear	51- Sealed Side Cover
8- Oil Plug	19- Bearing	30- Bearing	41- Key	52- Seal
9- Bolt	20- Bolt	31- Spacer	42- Bearing	
10- Top Side Cover	21- Spacer	32- Gear	43- Circlips	
11- Gear	22- Bearing	33- Spacer	44- Spacer	



3.15- BT...4.05 Types

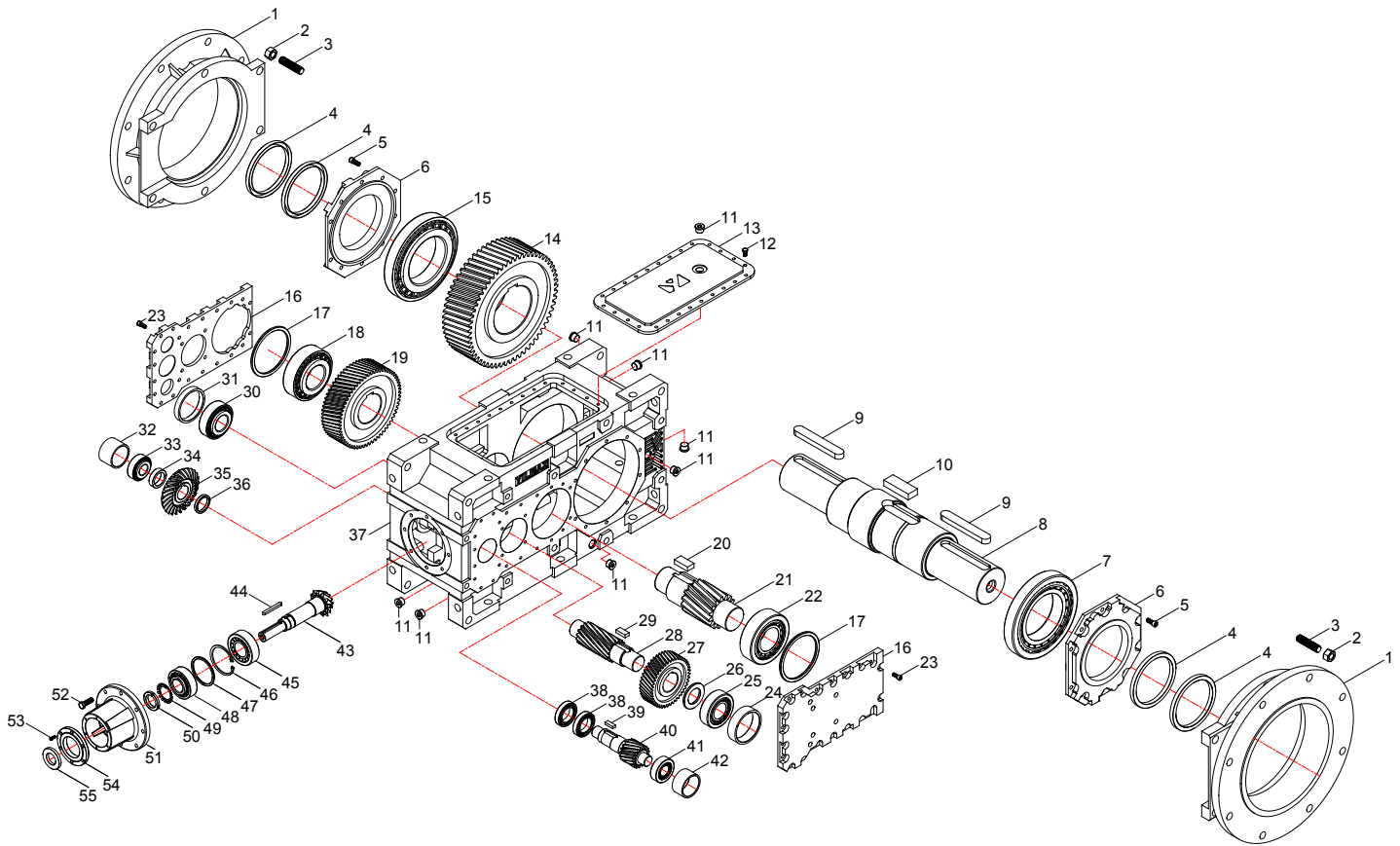

Standard BT...4.05 type basic part diagram. Parts may differ for special applications.

Standard Part List

1- Output Flange	12- Bolt	23- Bolt	34- Spacer	45- Bearing
2- Nut	13- Top Side Cover	24- Spacer	35- Gear	46- Circlips
3- Screw Pin	14- Gear	25- Bearing	36- Spacer	47- Spacer
4- Seal	15- Bearing	26- Spacer	37- Housing	48- Bearing
5- Bolt	16- Cover	27- Gear	38- Bearing	49- Locking Plate
6- Sealed Side Cover	17- Spacer	28- Gear	39- Key	50- Locking Nut
7- Bearing	18- Bearing	29- Key	40- Gear	51- Input Shaft Housing
8- Output Shaft	19- Gear	30- Bearing	41- Bearing	52- Bolt
9- Key	20- Key	31- Spacer	42- Spacer	53- Bolt
10- Key	21- Gear	32- Spacer	43- Gear	54- Sealed Side Cover
11- Oil Plug	22- Bearing	33- Bearing	44- Key	55- Seal



3.16- BT...4.08 Types

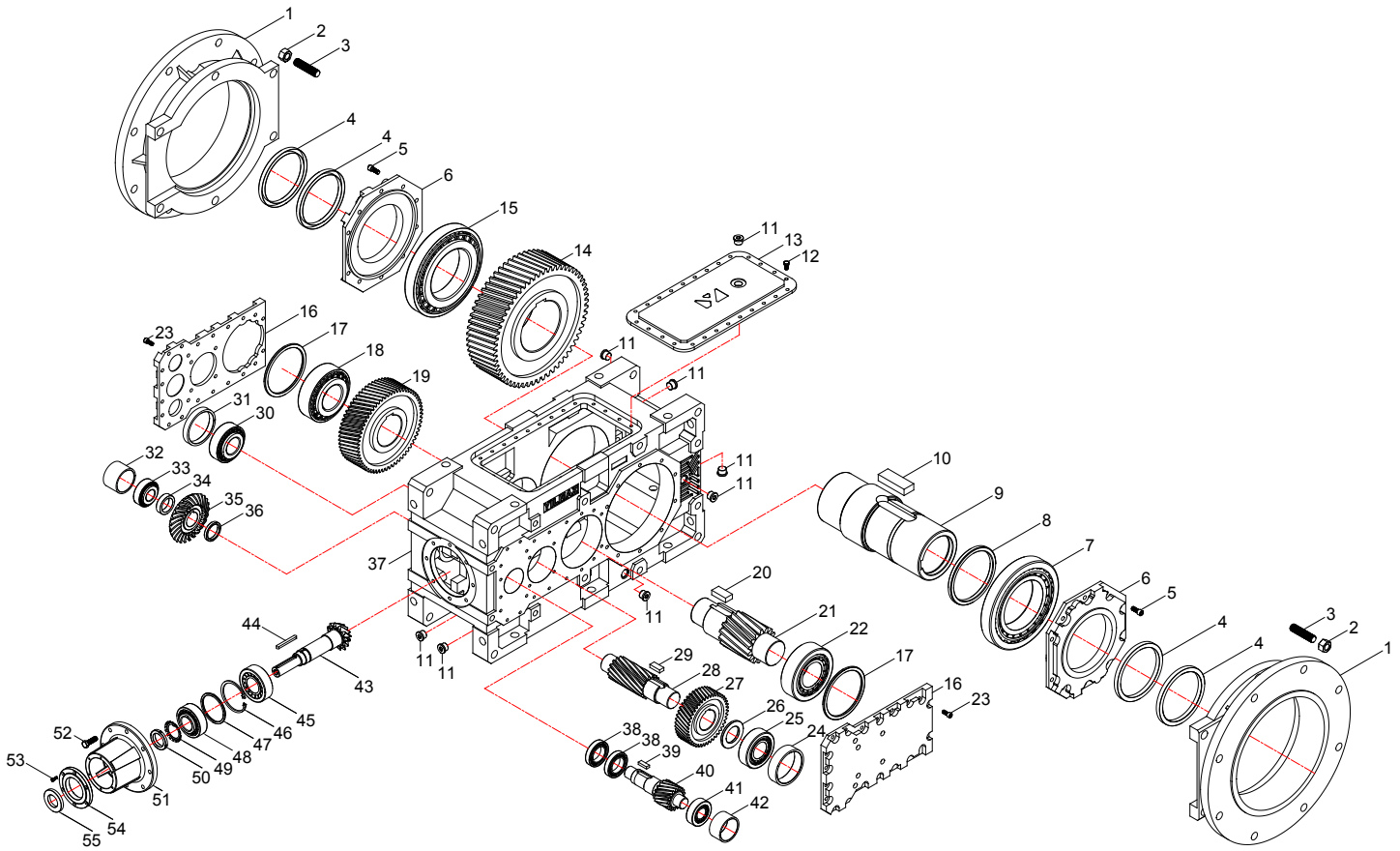

Standard BT...4.08 type basic part diagram. Parts may differ for special applications.

Standard Part List

1- Output Flange	12- Bolt	23- Bolt	34- Spacer	45- Bearing
2- Nut	13- Top Side Cover	24- Spacer	35- Gear	46- Circlips
3- Screw Pin	14- Gear	25- Bearing	36- Spacer	47- Spacer
4- Seal	15- Bearing	26- Spacer	37- Housing	48- Bearing
5- Bolt	16- Cover	27- Gear	38- Bearing	49- Locking Plate
6- Sealed Side Cover	17- Spacer	28- Gear	39- Key	50- Locking Nut
7- Bearing	18- Bearing	29- Key	40- Gear	51- Input Bearing Housing
8- Spacer	19- Gear	30- Bearing	41- Bearing	52- Bolt
9- Hollow Output Shaft	20- Key	31- Spacer	42- Spacer	53- Bolt
10- Key	21- Gear	32- Spacer	43- Gear	54- Sealed Side Cover
11- Oil Plug	22- Bearing	33- Bearing	44- Key	55- Seal



4- Safety

4.1- Intended Use

The gearbox is designed for usage in industrial machines. Please refer to our catalogue or our web page for the maximum permitted torques and speeds. The most important maximum permitted values are indicated on the nameplate of the product, but the whole data can be found on our product catalogues. Using the product out of the product catalogue/ nameplate's permitted ranges will cancel the warranty / manufacturer declaration and YILMAZ will not take any responsibility.

The gear units are intended to use for industrial machines and may only be used in accordance with the information provided in this manual the product catalogue and the nameplate of the gearbox. They comply with the applicable standards and regulations and meet the requirements of the directive 2006/42/EC. The gearbox must be started up, maintained and operated according to this manual. The gearbox must be incorporated with 2006/42/EC confirming parts/machines.



A motor connected to the gear unit is only allowed to be operated in the frequency entries so that the data provided on nameplate/catalogue of the gearbox is not exceeded and is accordance with the nameplate/catalogue. The speed range will be provided on the name plate if YILMAZ REDUKTOR is informed that the gear unit will be used with frequency inverter. If not informed, the nameplate will have a single fixed speed and only this speed is allowed.

The electric motor and frequency inverter must be in accordance with 2006/42/EC



If the gear units input is used with variable speed gear unit, YILMAZ must be informed before ordering and on the nameplate the allowed maximum and minimum speeds (speed range) will be provided. If not mentioned while ordering, the gearbox's speed will be a fixed single input speed and only this speed is allowed.



If the gear unit will be driven by belt / coupling / chain drive etc. the gearbox is only allowed to used according the nameplate/catalogue entries. Different speed, higher motor power, higher radial/axial loads etc. than nameplate/catalogue is not allowed.



The ambient temperature must be between +5 , +40 celsius and no corrosive media must attack the paint and seals. If there is different working conditions YILMAZ must be informed before ordering.



The gearbox maintenance (oil change / check) must be done according to this manual

4.2- Improper Use

Every usage which exceeds the limits stated above, the nameplate and catalogue of the product (especially higher torques and speeds) is not compliant with the regulations, and thus prohibited.

The operation of the gearbox is prohibited if;

- It was not mounted/installed according to regulations and this manual
- The gearbox is very dirty and soiled
- It is operated without lubricant
- It is operated out of the permitted values provided on catalogues and/or nameplate.



4.3- Safety Instructions

4.3.1- General Safety Instructions

4.3.1.1- Working on the Gearbox

- Inappropriately executed work can lead to injury or damage.

Make sure that the gear reducer is only installed, maintained and dismantled by trained technicians.

- Foreign objects spinning through the air can cause grave injury.

Before putting the gear reducer into operation, check that there are no foreign objects or tools near the gearbox.

4.3.1.2- Operation

- Touching hot surfaces can lead to burning.

Do not touch the gearboxes if their operation temperatures are too high, or use suitable safety equipment like gloves.

- Rotating machinery can lead to injuries. There is danger of being trapped or pulled in !

Keep a sufficient distance and make safeguarding to rotating machinery. See relevant norms EN349 + A1 and EN13857.

4.3.1.3- Maintenance

- An unintentional start of the machine during maintenance work can lead to serious accidents.

Make sure no one can start the machine while you are working on it.

- Even a brief running of the machine during maintenance work can lead to accidents if the safety devices are not operating.

Make sure that all safety devices are mounted and active.

4.3.1.4- Lubricant

- Extended, intensive contact with oils can lead to skin irritations.

Avoid extended contact with oil, and clean oil off skin immediately

- Hot oil can cause scalding.

When changing oil, protect yourself against contact of hot oil.

4.3.1.5- Ambient Conditions

- Standard gearboxes are allowed to work in ambient temperatures between +5 to +40 celsius unless differently specified on the nameplate. Using the gear unit out of this range can cause damage to the gearbox or environment. Over +40 celsius ambient conditions the gearbox surface temp. could be so high causing burns when touched.

- If the gear unit will be used in outdoor applications the gear unit must be protected from rain snow and dust. Entering substances inside the gear unit from seals can damage the gear unit. Observe the safety instructions for outdoor use EN12100 and EN 14121.



4.4- Tightening Torques

All screwed connections for which a tightening torque is specified, must be tightened with a calibrated torque wrench and checked. Use the following torques for the threaded bores over the gear unit housing. For connecting elements refer to the mechanical installation part.

Bolt Size	Class	Tightening Torque [Nm]
M8	8.8	15
M10	8.8	20
M12	8.8	20
M16	8.8	40
M20	8.8	80
M24	8.8	200

4.5- Case of Fire

The gear reducer itself is not combustible. However, it contains a synthetic or mineral gear oil.

Please observe the following if the gearbox is situated in a burning environment.

4.5.1- Suitable Extinguishing Agents, Protective Equipment

Always keep suitable extinguishing, protective equipment like carbon dioxide, powder, foam, fog easily accessible around the gearbox.

- Higher temperatures produce irritating steam.

Use a protective breathing apparatuses.



4.5.2- Unsuitable Extinguishing Agents

Do not spray with water !





5- Checking Before the Gear Unit or Geared Motor is Installed



If your gearbox is with motor , please also refer to the manual of the motor manufacturer.

Before you install the gearbox you have to be sure that the gearbox is arrived with the all necessary equipment and without damage. Things to take into consideration before you start to install the unit;

- You have received the correct operation manual of the your product.
- The gearbox and all its parts are transported without damage.
- The gearbox is stored correctly according the instructions in this manual
- You have the latest product catalogue or you have access to internet.

5.1- Transportation

When the goods arrive, first check for any damage. If some damage observed, immediately contact the transport company and inform about the damage. Contact YILMAZ for the damage and do not start to install the unit until it is agreed that the damage has no affect of operation.



Use the upper foot connection holes for lifting up the gear unit by using eyebolts. The eyebolts should be capable to carry the weight of gearboxes. Do not hang additional loads on the gearbox while lifting. Use suitable hoisting equipment which is capable to hold the gear units weight. Refer to the catalogue for various types weights. If the gearbox is delivered with steel carrying construction use the construction holes for lifting the gear unit. See drawing bellow for hoisting point.



Do not stay beneath / under the lifting / hoisting equipment which may cause serious injuries by falling down objects, accidentally movements, unexpected accidents.

Falling or hard movement can damage the gear unit.



Only use hoisting and securing equipment which is permitted for the size / weight of your gearbox. Ensure that the load is slowly and carefully handled and placed.

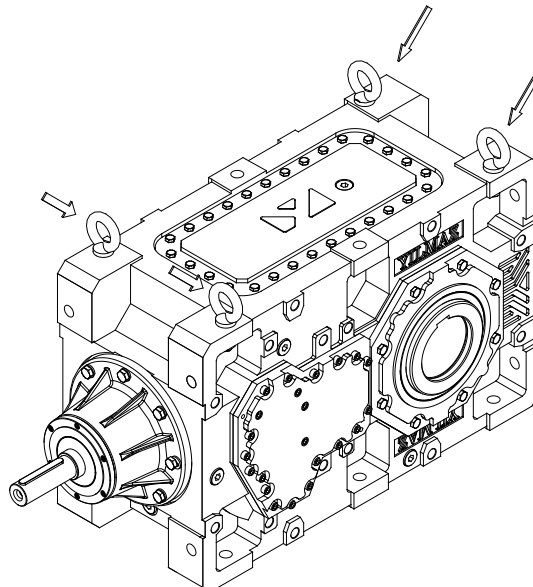



5.2- Storage

If the gear unit or geared motor will be stored up to 3 years refer to the following instructions;

With Packing ;

- Use corrosion protection oil for the output shaft and connection surfaces like flange surface or foot assembling surfaces. Seal the unit in a plastic wrap and pack it in container. A moisture indicator should be placed around the container to observe the moisture. Relative atmospheric humidity should not exceed 50%. The container should be kept under roof which protects from snow and rain. Under this condition the gear unit can be stored up to 3 years with regular checks. The ambient temperature should be between - 5 to + 60 Celsius degrees

Without Packing ;

- Use protection oil for the output shaft and connection surfaces like flange surface or foot assembling surfaces. If no packing is used and the gearbox is stored without packing, the ambient temperature should be between + 5 to + 60 Celsius degrees. The gearbox must be kept under enclosed roof with constant temperature and constant humidity which is not exceeding 50 %. The storage should be free of dust and dirt and ventilated with filter. If the gearbox is stored without packing it is recommended not to store more than 2 years and regular checking during this time is recommended. If stored in open areas protect against insect damage.

6- Installing The Gear Unit

6.1- Before You Start ;

- Observe the gear unit for damages of storage or transportation. If any damage please contact YILMAZ REDUKTOR.

- Be sure that you have all the equipment necessary for installing like; Spanners, torque wrench, shims and distance rings, fixing devices for input and output elements, lubricant, bolt adhesive etc.



- This manual is not for 94/9/EC (ATEX) conforming gear units. For 94/9/EC conforming gear units refer to the ATEX range manual. ATEX conforming gear units have name plates indicating the zone and the temperature class and are different from standard type geared units. Therefore standard units can not be installed on potentially explosive atmospheres.



6.2- Check the Shaft Dimensions to Fit

Type	Hollow Output Shaft Diameter [mm]	Hollow Output Shaft Tolerance (H8) [mm]	Solid Output Shaft Diameter [mm]	Solid Output Shaft Tolerance (DIN 748) (m6)
B.03	60	+0.03 0	70	+0.03 +0.01
B.04	80	+0.03 0	80	+0.03 +0.01
B.05	95	+0.04 0	100	+0.04 +0.01
B.06	105	+0.04 0	110	+0.04 +0.01
B.07	115	+0.04 0	120	+0.04 +0.01
B.08	125	+0.04 0	130	+0.04 +0.02
B.09	135	+0.04 0	140	+0.04 +0.02
B.10	150	+0.04 0	160	+0.04 +0.02
B.11	165	+0.04 0	170	+0.04 +0.02
B.12	180	+0.04 0	180	+0.04 +0.02
B.13	190	+0.05 0	200	+0.05 +0.02
B.14	210	+0.05 0	220	+0.05 +0.02
B.15	230	+0.05 0	230	+0.05 +0.02

6.3- Check the Ambient Temperature ;

The ambient temperature must be between +5 celsius to +40 celsius for standard type gear units. If there is different ambient conditions please contact YILMAZ REDUKTOR for special solutions.

6.4- Check the Voltage Supply ;

The standard geared motors are supplied with 230/400 V 50/60Hz. up to 3kW including 3kW and 400/690 V 50/60 Hz. over 3kW and is indicated on the motors name plate unless it is differently ordered. In case of only gear unit is supplied from YILMAZ please observe the name plate of the electric motor and the instructions of the supplier. Check the basic electric connection diagrams given on next pages. Use experienced electric technician.



Using wrong connection or voltage can damage the electric motor or environment.



The following wiring diagram is for standard 230/400 V 50Hz AC electric motors. For different voltages please contact YILMAZ REDUKTOR. For gear units supplied without motor, refer to the motor manufacturers user manual.



The electric connection must be done by experienced electric technician.
The gearbox, the motor and the brake must be grounded to prevent potential differences of earth and gearbox / motor.

Kutup Sayısı	Nominal Güç 400V, 50Hz	
	230V (Δ) / 400 V (Y)	400V (Δ)
2 veya 4	\cong 3 kW	\cong 4 kW
6	\cong 2,2 kW	\cong 3 kW
8	\cong 1,5 kW	\cong 2,2 kW
Çalışma Prensibi	Direkt	Direkt veya Y/ Δ

Basic Motor Connection Wiring Diagram

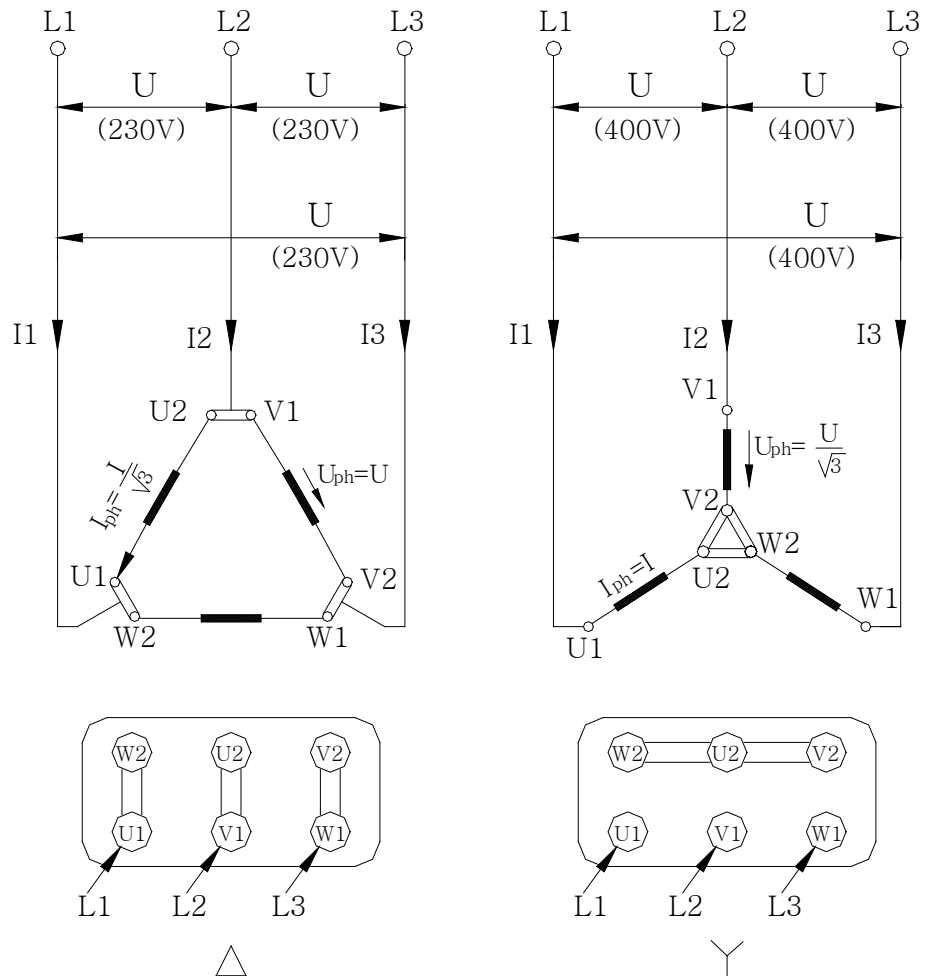

Operating Instructions

B Series

Mounting



Standard Type Brakes Basic Wiring Diagram



The electric connection must be done by experienced electric technician.
The gearbox and the motor must be grounded to prevent potential differences of earth and gearbox/motor.

Delayed Running Brake (220 V)

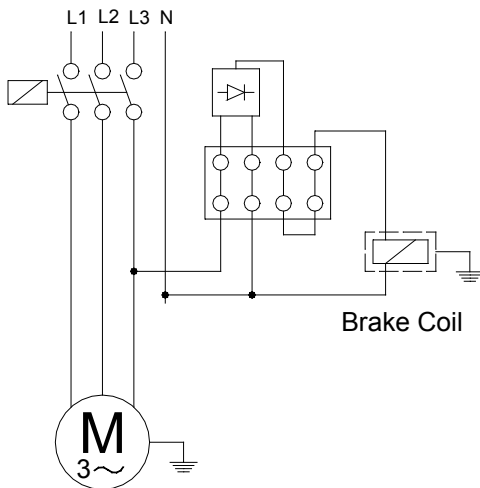

Sudden Brake (220 V)

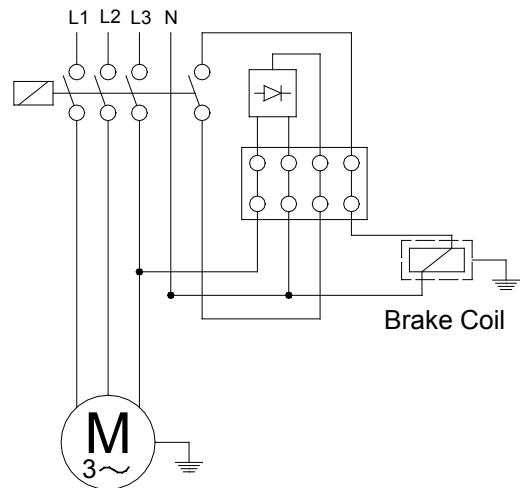

Delayed Running Brake (24 V)

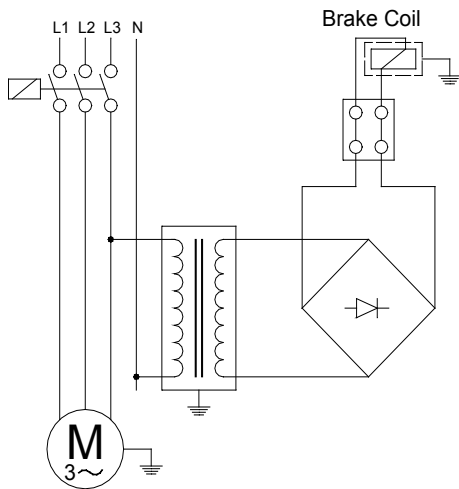

Sudden Brake (24 V)

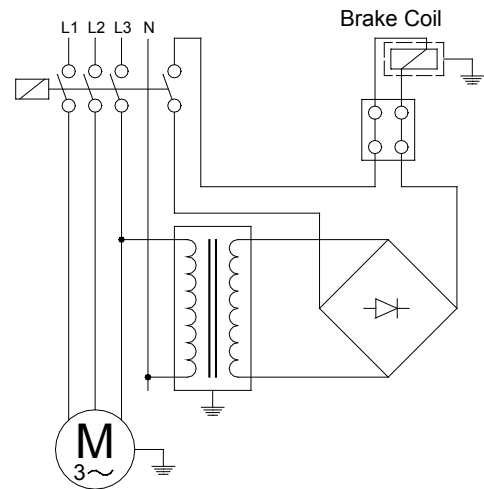



6.5- Check the Mounting Position;

The mounting position must be in accordance with the mounting position mentioned on the name plate. If different please contact YILMAZ REDUKTOR for possibilities of using in a different mounting position. Refer to the mounting positions and oil quantities on this manual and adjust the oil level accordingly with the recommended oil types given on this manual.



Do not mix synthetic oils with mineral oils which can cause serious damage on the gear unit.

6.6- Usage of Breather Plug ;

Breather plugs are not needed for B series under normal ambient and working conditions (Up to 30 degree Celsius ambient temperature and up to 8 hours per day) . If heavy ambient conditions and long time working hours then breather plugs are recommended by YILMAZ REDUKTOR which are delivered with the gearbox together. Replace the breather plug with the upper plug according to your mounting position.



Some plug positions are not machined according to mounting position. If no mounting position is mentioned while ordering the standard M1 position plugs are machined.

6.7- Check the Oil Level ;

On the oil plugs tables the oil plugs are shown. Please refer to those tables and be sure that the oil level is correct according the mounting position by screwing half way out the level plug and see if oil comes out from that plug. If oil comes out tighten the plug again. If no oil comes out take out the filling plug and add oil until oil comes out from the level plug and tighten both plugs after finish. Be sure you are using the correct oil mentioned on the oil tables on this manual.



Do not mix synthetic oils with mineral oils which can cause serious damage on the gear unit.

6.8- Check Shaft Ends and Mounting Surfaces;

Before you start installing be sure that all the connection elements are free of oil and dust. The output shaft may be protected by anti-corrosion oil. Please remove this using available solvents on your market. By using this do not touch sealing lips or painting of the housing.

6.9- Cover Against Corrosive Ambient;

If the gear unit will be placed on a corrosive ambient be sure that the output seals are covered so that no corrosive material, chemicals or water touches the seals. Any pressure coming from outside over the seals can cause substances to enter the gearbox and cause serious damage to the gear unit. If pressure or abrasive material can not be prevented from coming over the sealing, contact YILMAZ for solutions.



Abrasive material, chemicals, water, positive or negative pressure exceeding 0,2 bar can affect or damage the sealing lip or output shaft. Substances entering to the inside from the seals can cause serious damage to the gear unit.



6.10- Check Accessibility to Filling, Breather and Drain Plugs ;

The filling, breather and drain plugs must be freely accessible for further checking and service.

7- Mechanical Installation ;

The gear unit can only be installed using the given connection points like feet and flanges.



To install the gear unit without the given connection points can cause serious injuries by loosening or breaking the gear unit. Even the gear unit is installed totally correctly according this manual, be sure that no one will be harmed by accidentally brake downs or loosening.



The mounting plate must be rigid enough not allowing torsions, flat enough to prevent strains by tightening the bolts and stable enough not allowing vibrations. By using chain drives this becomes much more important because of the polygon effect on chain drives. According to your connection elements the maximal permitted radial and axial load of the gear unit must be in accordance with your application. Check the product catalogue for permitted radial loads and calculation.



If the output or input shaft is overloaded by radial or axial loads it can cause serious damage to the gear unit.

Secure the gear unit using 8.8 or higher quality bolts.



Cover all the turning parts to prevent touching. Turning parts can cause severe or fatal injuries.

For different kind of basic installations refer to the following illustrations.



7.1- Installing Customer Shaft with Shoulder

7.1.1- Use anti-seize assembling paste available on your market. Use a brush to apply the paste.

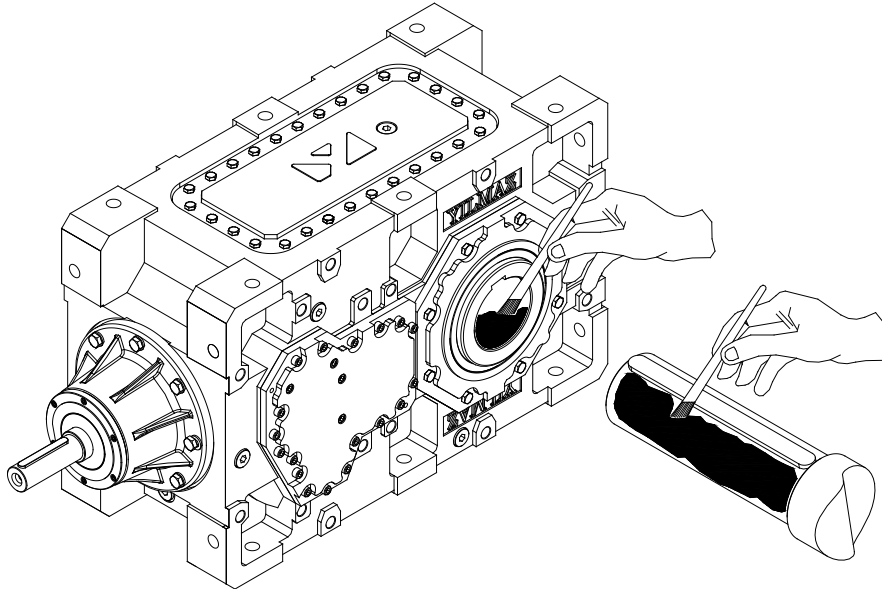

7.1.2- Fasten the bold as shown below.

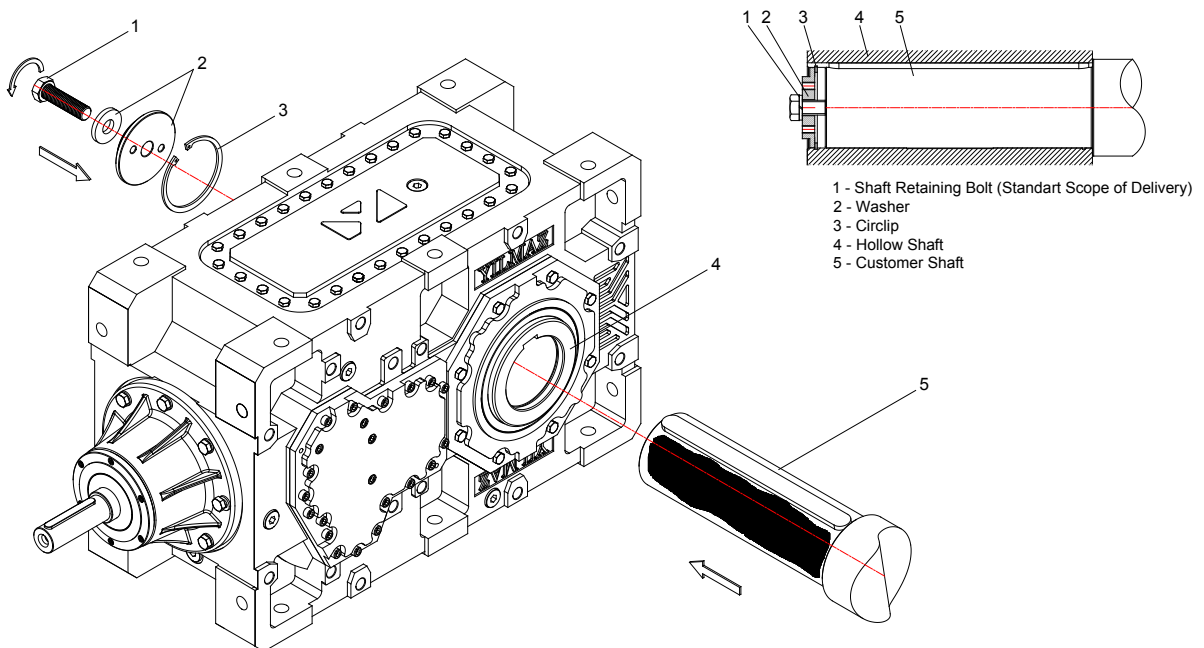



7.2- Disassembling Customer Shaft with Shoulder

7.2.1- Disassemble the bolt and take out the parts as shown

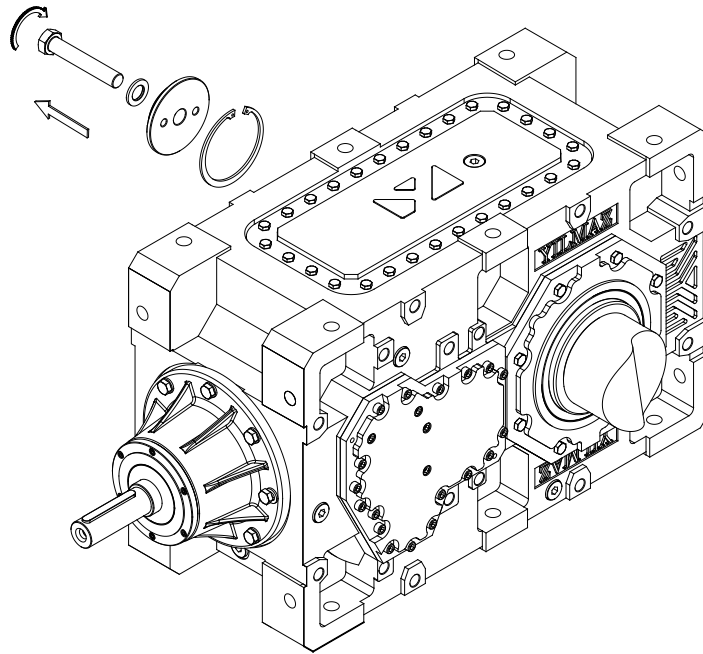



7.2.2- Use the disassemble set from YILMAZ and fasten the bold as shown below to take out the output shaft.

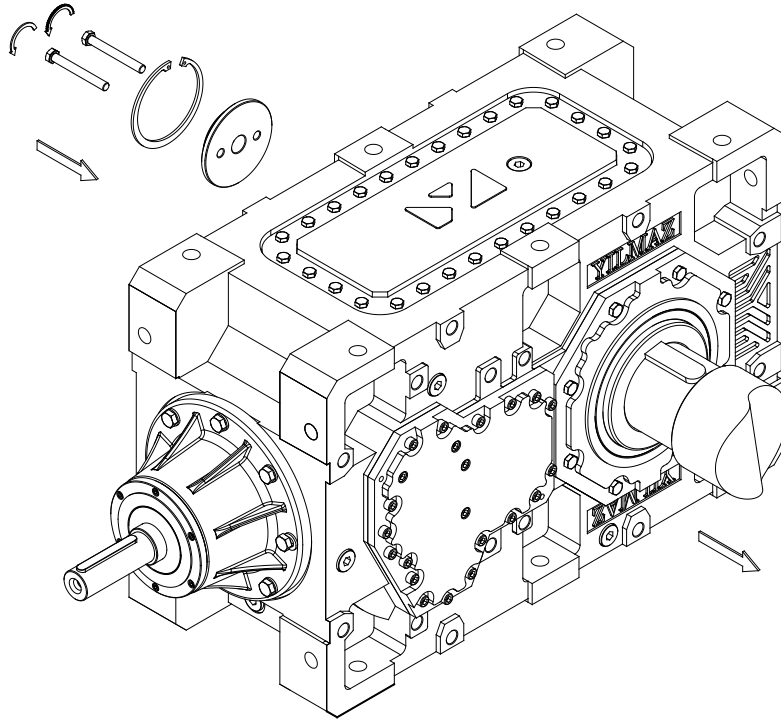



7.3- Fitting Output Shaft Elements

Use the following illustration to assemble output shaft units

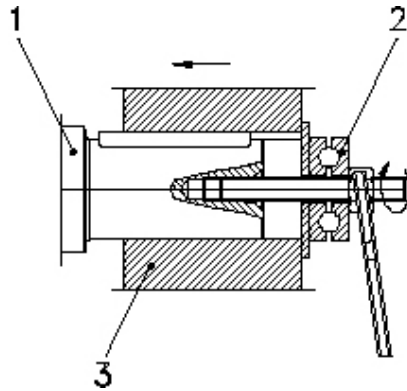

- 1) Gear Shaft End
- 2) Thrust Bearing
- 3) Coupling Hub

7.4- Correct Position of Output Shaft Elements

The Output Shaft unit (transmission elements) must be placed as close as possible to the gear unit to get radial load as close as possible.

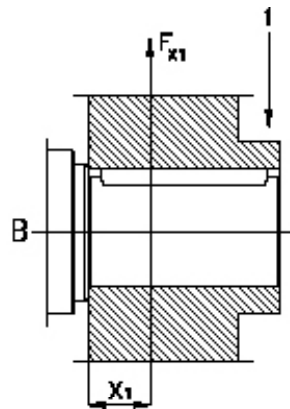
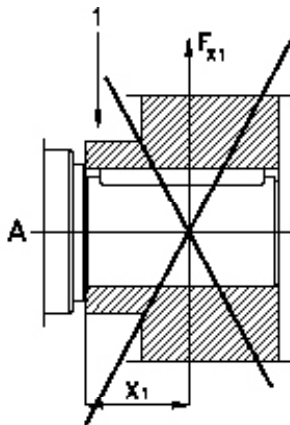

- 1) Hub



7.5- Fitting Couplings

7.5.1- While fitting couplings be sure that there is some clearance between the two shafts

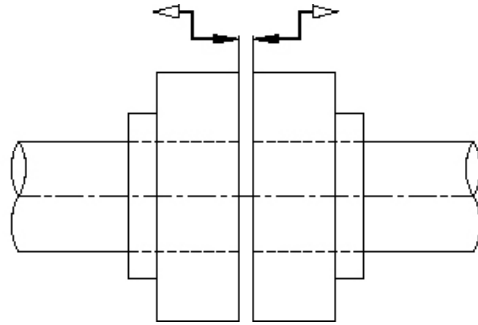

7.5.2- While fitting couplings be sure that there is no eccentricity between the two shafts.

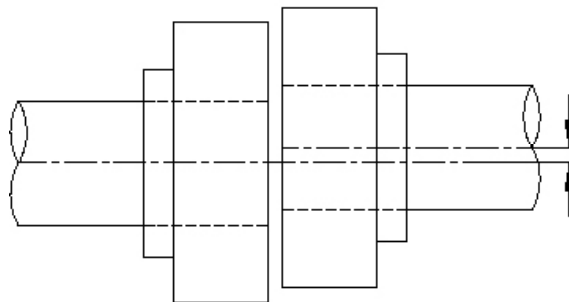

7.5.3- While fitting couplings be sure that the two shafts are not angular miss-aligned.

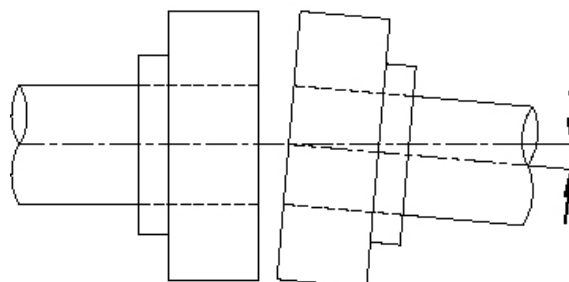



7.6- Shaft Tightening Torques

Use the following table for shaft tightening torques.

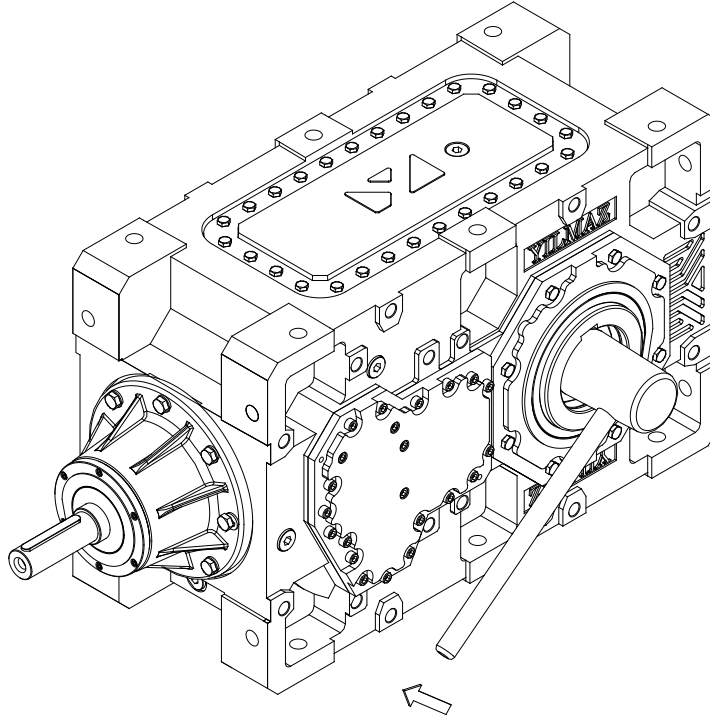

Type	Bolt	Tightening Torques [Nm]
B.03	M20	80
B.04	M20	80
B.05	M24	200
B.06	M24	200
B.07	M24	200
B.08	M24	200
B.09	M30	400
B.10	M30	400
B.11	M30	400
B.12	M30	400
B.13	M30	400
B.14	M30	400
B.15	M36	1000



7.7- Recommended Shaft Dimensions for B...00 Types

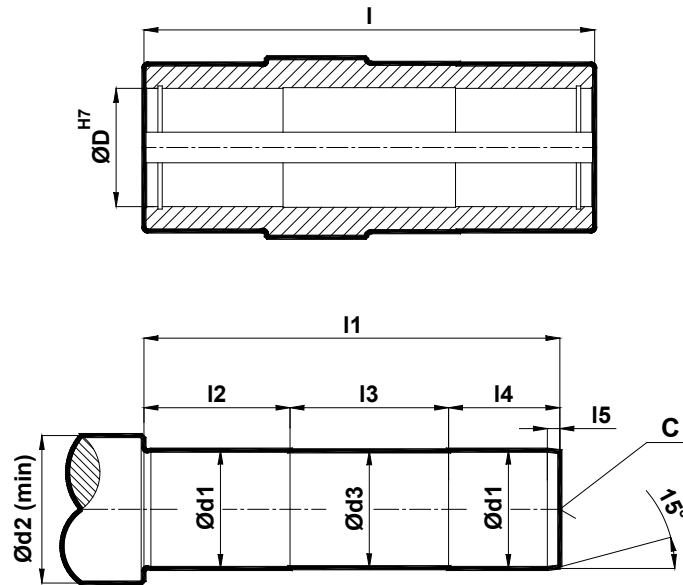

	d1	d2	d3	l	l1	l2	l3	l4	l5	c
B03	60 (h6)	74	59	280	255	95	90	70	4	M20
B04	80 (h6)	98	79	280	255	95	90	70	4	M20
B05	95 (h6)	118	94	330	301	115	100	86	5	M24
B06	105 (h6)	128	104	330	301	115	100	86	5	M24
B07	115 (h6)	138	114	390	361	135	120	106	5	M24
B08	125 (h6)	154	124	390	361	135	120	106	5	M24
B09	135 (m6)	162	134	470	436	165	140	131	6	M30
B10	150 (m6)	178	149	470	436	165	140	131	6	M30
B11	165 (m6)	198	164	540	505	185	170	150	7	M30
B12	180 (m6)	218	179	540	505	185	170	150	7	M30
B13	190 (m6)	228	189	670	626	225	220	181	8	M30
B14	210 (m6)	258	209	670	626	225	220	181	8	M30
B15	230 (m6)	278	229	760	710	225	250	205	8	M36



8- Maintenance and Inspections

Under normal ambient and working conditions the gear unit should be checked according the following intervals. (For definition of normal working conditions refer to the product catalogue : "Selecting Gearbox" section) ;

Item to Check / Replace	Every 3000 Working Hours or Every 6 Months	Every 4000 Working Hours	Every 10000 Working Hours or Every 3 Years	Every 25000 Working Hours
Check for Oil Leakage	x			
Check for Oil Level	x			
Check for Oil Leakage from Seals	x			
Check Bearing's Noise		x (Change if Necessary)		
Change Mineral Oil			x (See Below for Details)	
Change Synthetic - PAO Oil				x (See Below for Details)
Change Sealing				x
Change Bearing Grease				x
Change Bearings				x
Check for Noise Changes				x

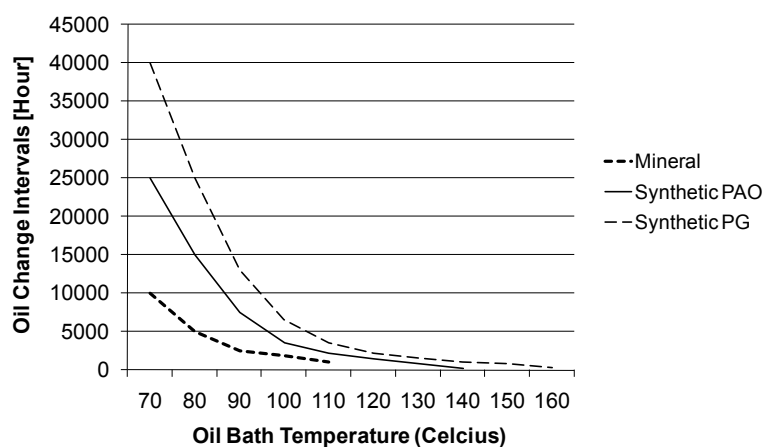

For normal ambient conditions 70 degrees celsius oil bath temp. should be taken as reference

* For our B series gearboxes mineral oil is used unless it is differently ordered. For oil type and quantities refer to the following tables.

Operating Instructions





B Series

Lubrication



9- Lubrication

9.1- Oil Types

Lubricant	DIN 51517-3	Ambient Temperature [°C]		ISO VG	Beyond Petroleum	Castrol	Klüber Lubrication	Mobil	Shell
		Dip Lubrication	Forced Lubrication						
Mineral Oils	CLP	0 ... +50	–	680	Energol GR-XP 680	Alpha SP 680	Klüberoil GEM 1-680 N	Mobilgear XMP 680	Omala 680
		-5 ... +45	–	460	Energol GR-XP 460	Alpha SP 460	Klüberoil GEM 1-460 N	Mobilgear XMP 460	Omala F460
		-10 ... +40	+15 ... +40	320	Energol GR-XP 320	Alpha SP 320	Klüberoil GEM 1-320 N	Mobilgear XMP 320	Omala F320
		-15 ... +30	+10 ... +30	220	Energol GR-XP 220	Alpha SP 220	Klüberoil GEM 1-220 N	Mobilgear XMP 220	Omala F220
		-20 ... +20	+5 ... +20	150	Energol GR-XP-150	Alpha SP 150	Klüberoil GEM1-150 N	Mobilgear XMP150	Omala 150
		-25... +10	+3 ... +10	100	Energol GR-XP 100	Alpha SP 100	Klüberoil GEM 1-100 N	–	Omala 100
Synthetic Oils	CLP PG	-10 ... +60	–	680	Energyn SG-XP 680	–	Klübersynth GH 6 -680	Mobil Glygoyle 680	Tivela S 680
		-20 ... +50	–	460	Energyn SG-XP460	Aphasyn PG460	Klübersynth GH 6-460	Mobil Glygoyle 460	Tivela S 460
		-25 ... +40	+5 ... +40	320	Energyn SG-XP320	Aphasyn PG320	Klübersynth GH 6-320	Mobil Glygoyle 320	Tivela S 320
		-30 ... +30	0 ... +30	220	Energyn SG-XP 220	Aphasyn PG 220	Klübersynth GH 6-220	–	Tivela S 220
		-35 ... +20	-5 ... +20	150	Energyn SG-XP 150	Aphasyn PG 150	Klübersynth GH 6 -150	–	Tivela S 150
		-40 ... +10	-8 ... +10	100	–	–	Klübersynth GH 6 -100	–	–
	CLP HC	-10 ... +60	–	680	–	–	Klübersynth GEM4-680 N	Mobilgear SHCXMP680	–
		-20 ... +50	–	460	Energyn EP-XF 460	Alphasyn T 460	Klübersynth GEM4-460 N	Mobilgear SHC XMP460	Omala HD 460
		-25 ... +40	+5 ... +40	320	Energyn EP-XF 320	Alphasyn T 320	Klübersynth GEM4-320 N	Mobilgear SHC XMP 320	Omala HD 320
		-30 ... +30	0 ... +30	220	Energyn EP-XF 220	Alphasyn T 220	Klübersynth GEM4-220 N	Mobilgear SHC XMP 220	Omala HD 220
		-35 ... +20	-5 ... +20	150	Energyn EP-XF 150	Alphasyn T 150	Klübersynth GEM4-150 N	Mobilgear SHC XMP 150	Omala HD 150
		-40 ... +10	-8 ... +10	100	–	–	Klübersynth GEM4-100 N	–	–
Food Grade Oil	CLP NSF H1	-15 ... +25	+5 ... +25	320	–	Optileb GT 320	Klüberoil 4 UH1-320 N	Mobil SHC Cibus 320	Cassida Fluid GL-320
Bio degradable Oil	CLP E	-25 ... +40	+5 ... +40	320	–	Tribol BioTop 1418-320	Klübersynth GEM 2-320	–	–
Mineral Greases [-20 +130 Working Temperatures °C]					Energrease LS 3	Spheerol AP3	Centoplex 2 EP	Mobilux EP 3	Alvania RL3
Synthetic Greases [-30 +130 Working Temperatures °C]					Energrease SY 2202	–	Petamo GHY 133 N	Mobiltemp SHC100	Cassida RLS 2



9.2- Changing the Oil

Refer to the nameplate to find out the correct oil type filled inside the gearbox.



- Do not mix synthetic oils with mineral oils which will cause serious damage to the gear unit. The oil change must be done by using the filling, draining and level plugs according the mounting position illustrated at oil plugs tables.



- Extended, intensive contact with oils can lead to skin irritations. Avoid extended contact with oil, and clean oil off skin immediately.



- Hot oil can cause scalding. When changing oil, protect yourself against contacting hot oil, use protective gloves.

9.3- Oil Quantities

H and B Series Oil Quantities (lt)													
	H0322 B0323	H0323	H0422 B0423	H0423	H0522 B0523	H0523	H0622 B0623	H0623	H0722 B0723	H0723 H0724 B0724	H0822 B0823	H0823 H0824 B0824	H0922 B0923
M1	8	9	10	11	15	16	19	21	31	35	37	40	48
M3	8	9	10	11	15	16	19	21	31	35	37	40	48
M2	9	11	12	13	18	19	23	25	37	42	44	48	58
M4	10	12	13	15	20	21	25	27	40	46	48	52	62
M5*	9	10	11	12	16	17	20	23	34	38	41	44	53
M6*	9	11	12	13	17	18	21	24	36	40	43	46	56

	H0923 H0924 B0924	H1022 B1023	H1023 H1024 B1024	H1122 B1123	H1123 H1124 B1124	H1222 B1223	H1223 H1224 B1224	H1322	H1323 H1324 B1324	H1422	H1423 H1424 B1424	H1522	H1523 H1524 B1524
M1	53	61	65	83	90	122	128	150	162	180	190	225	245
M3	53	61	65	83	90	122	128	150	162	180	190	225	245
M2	63	73	78	100	108	145	150	180	190	215	225	270	290
M4	67	79	87	108	115	150	165	190	205	234	245	290	315
M5*	58	67	70	91	100	134	141	165	178	198	209	248	265
M6*	61	70	74	96	104	140	148	173	187	208	219	260	278



9.4- Oil Plugs

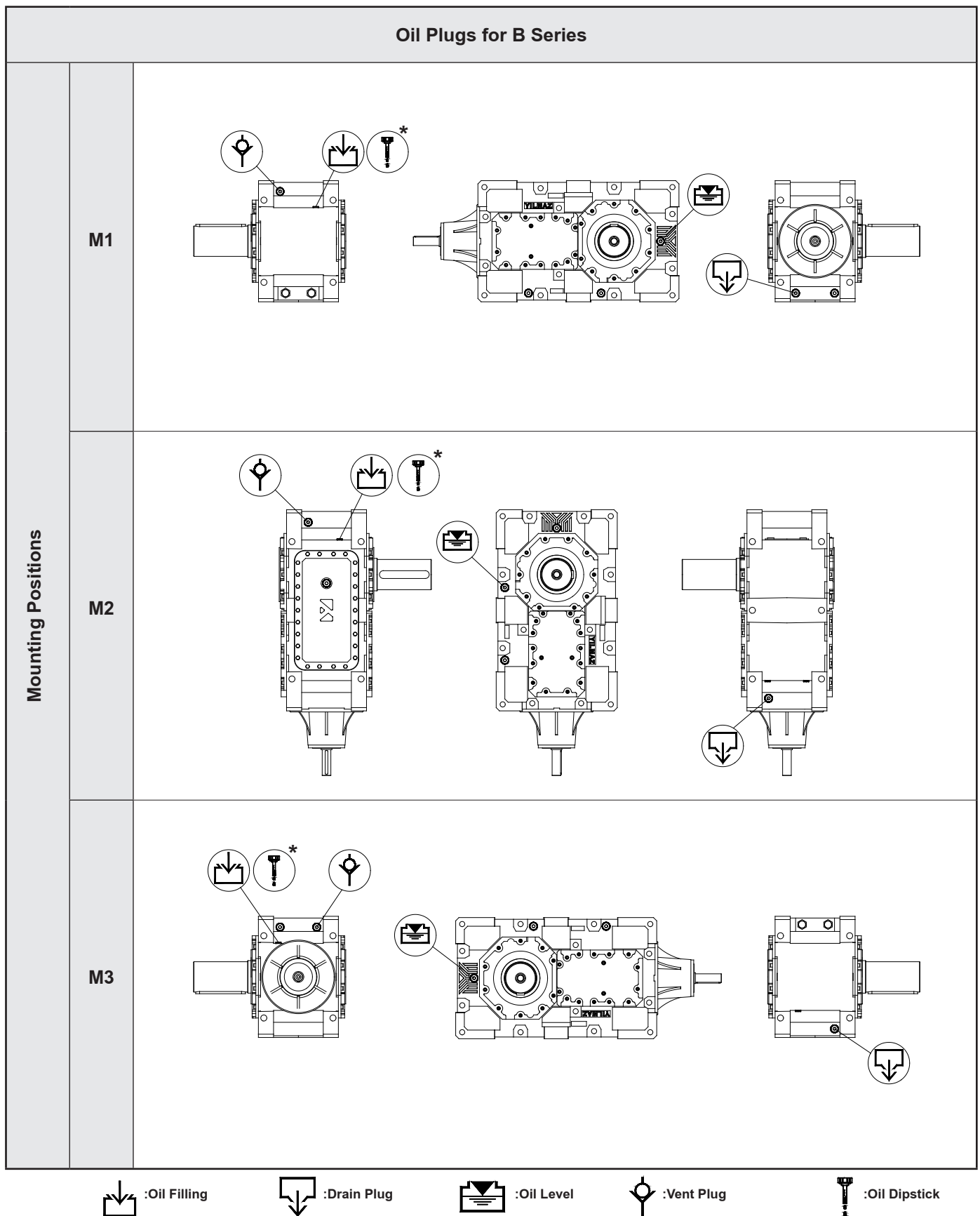

*:Option



9.4- Oil Plugs

		Oil Plugs for B Series
Mounting Positions	M4	
	M5	<p>It is given for the gearboxes which are without additional oil supply options and with sealed bearings.</p>
	M6	<p>It is given for the gearboxes which are without additional oil supply options and with sealed bearings.</p>



:Oil Filling



:Drain Plug



:Oil Level



:Vent Plug



:Oil Dipstick

*:Option



9.5- Mounting Positions

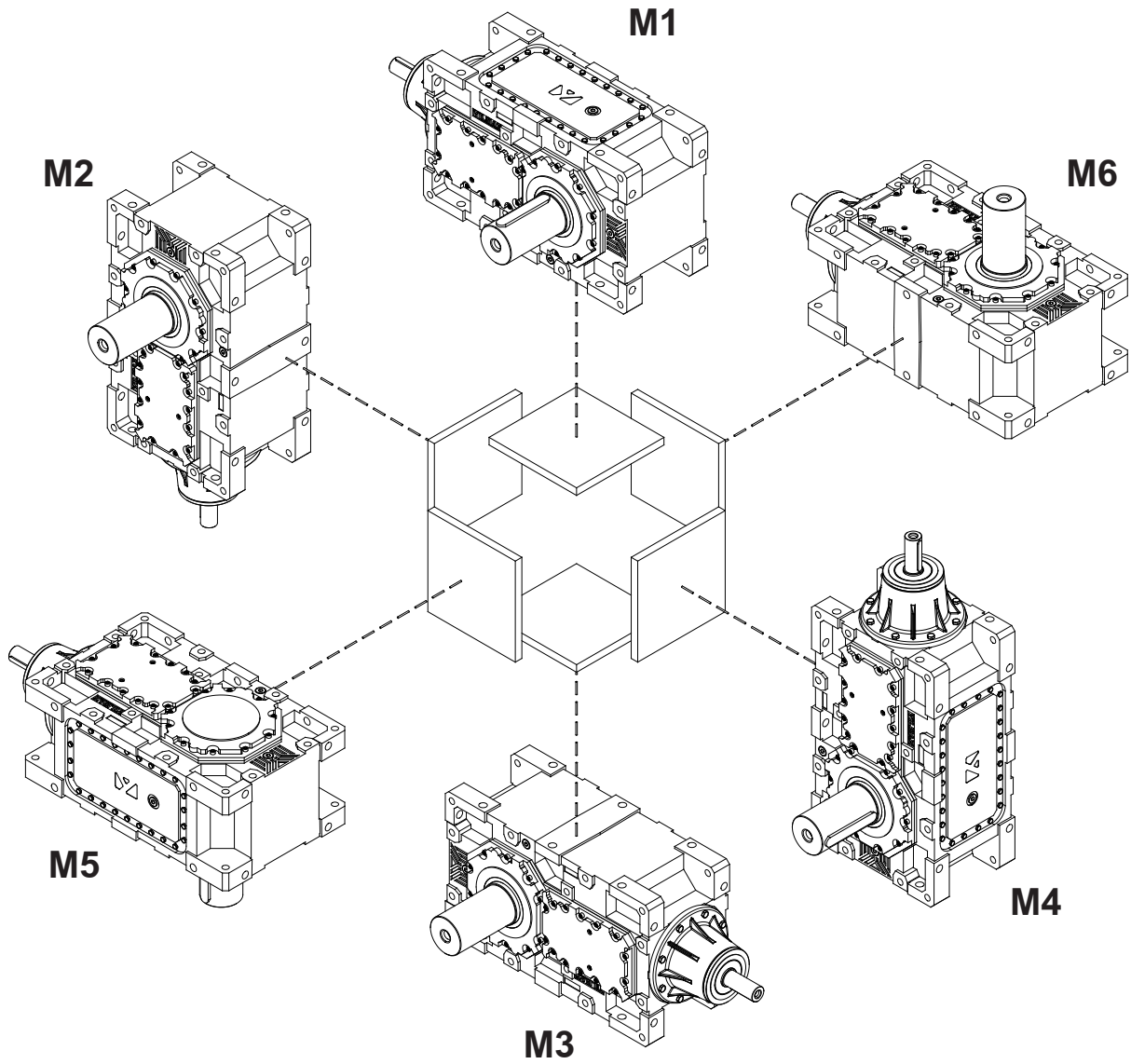

Operating Instructions

B Series

Cooling Options



10- Cooling Options

Cooling Options	
F Fan Cooling	
S Cooling Coil	
HE1 Heat Exchanger with External Motor Pump	
HE2 Heat Exchanger with Shaft End Pump	
R Air / Oil Heat Exchanger	



10.1- Fan Cooling ;

Standart Scope of Delivery ;

- Integrated fan on the input shaft
- Fan cover



The hatched areas shown below on the drawing must be kept free for clean and easy air intake .

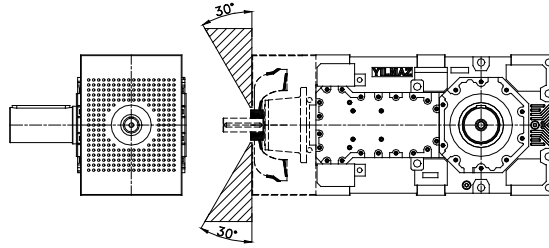

10.2- Cooling Coil ;

Standart Scope of Delivery ;

- Cooling Coil at the bottom of Gearbox
- Inlet and outlet ports for cooling water

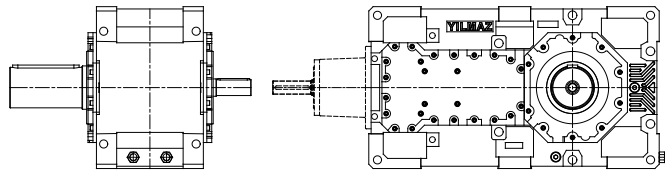

Maximal water inlet temperature must be 30°C. Minimum water flow rate for gear units with cooling coil must be 4 lt/min for H03/B03....H08/B08 and 8 lt/min for H09/B09....H15/B15. There are inlet and outlet ports for customers. Port sizes can be seen at the below table.

Gearbox Size	Pipe Connection Diameter	Flow Rate (lt/min)	Max. Water Inlet Temperature (C)
H03...-H08 B03...-B08	G 1/2"	4...6	30
H09...-H15 B09...-B15	G 3/4"	8...10	30



10.3- Cooling with Heat Exchanger ;



You can see the minimum cooling water flow rate for heat exchanger types below. Maximum cooling water inlet temperature must be 30°C.

Heat Exchanger Type	Cooling Power [kW]	Oil Flow Rate [lt/d]	Pump Power [kW]	Min. Cooling Water Flow Rate [lt/d]
E1	1,5	5,6	0,18	2,2
E2	3,0	5,6	0,18	5,6
E3	5,0	11,5	0,37	7,2
E4	10	22,4	0,75	14
E5	20	46,2	1,5	29
E6	30	72,8	2,2	43
E7	45	98	3,0	65

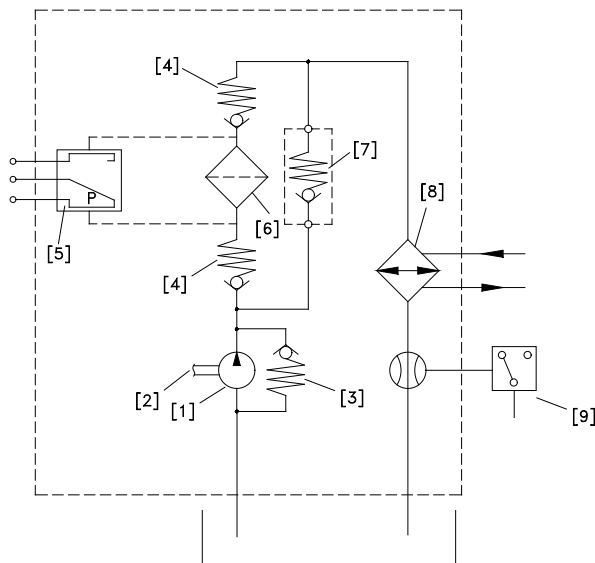

Flow Diagram

Heat Exchanger (Shaft End Pump)

- 1 - H ; 4 cm/rev pump
- B ; 16 cm/rev pump
- 2 - Shaft end of gearbox
- 3 - 3 bar pressure valve
- 4 - Bypass valve (optional)
- 5 - 20 μ oil filter
- 6 - Pressure differential led (optional)
- 7 - Bypass valve (optional)
- 8 - Flow switch (optional)

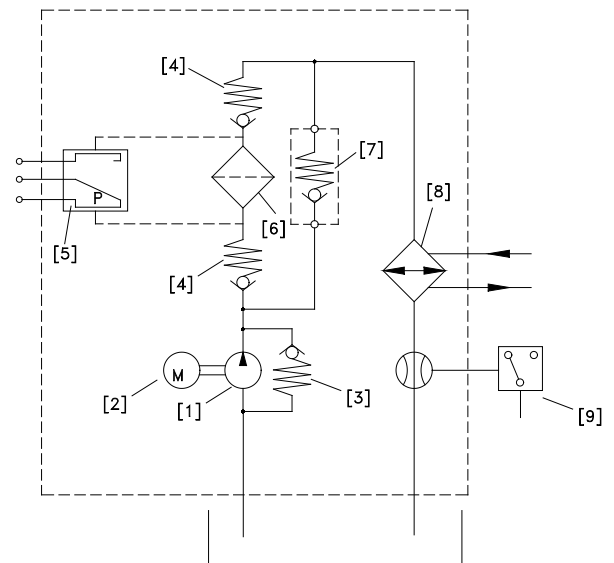

Flow Diagram

Heat Exchanger (External Motor Pump)

- 1 - 4 cm/rev pump
- 2 - 0,37 kW, 1400 rpm pump motor
- 3 - 3 bar pressure valve
- 4 - Bypass valve (optional)
- 5 - 20 μ oil filter
- 6 - Pressure differential led (optional)
- 7 - Bypass valve (optional)
- 8 - Flow switch (optional)



10.4- Cooling with Air / Oil Heat Exchanger ;



You can find technical informations about air / oil heat exchangers below. Technical informations are valid for 20°C ambient temperature.

Air / Oil H. Exchanger Type	Cooling Capacity [kW]	Oil Volume [lt/m]	Pump Motor Power [kW]
R1	6,0	62	2,2
R2	9,5	62	2,2
R3	17,5	98	3,0
R4	25	98	3,0
R5	29,5	98	3,0

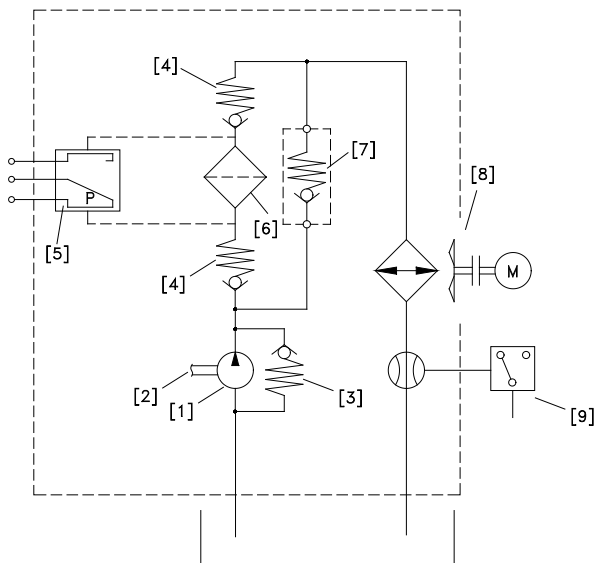

Flow Diagram
Air / Oil Heat Exchanger (Shaft End Pump)

- 1 - Shaft end pump
- 2 - Shaft end of gearbox
- 3 - 3 bar pressure valve
- 4 - Bypass valve (optional)
- 5 - Pressure differential led (optional)
- 6 - 20 µ oil filter
- 7 - Bypass valve (optional)
- 8 - Air / oil heat exchanger
- 9 - Flow switch (optional)

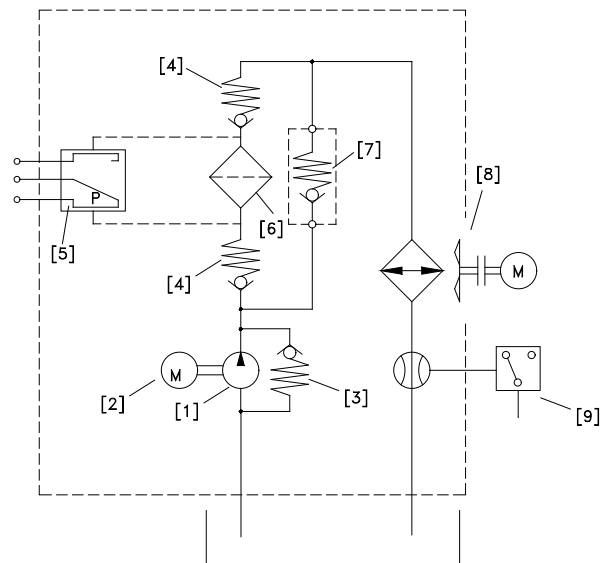

Flow Diagram
Air / Oil Heat Exchanger (External Motor Pump)

- 1 - External pump
- 2 - Pump motor
- 3 - 3 bar pressure valve
- 4 - Bypass valve (optional)
- 5 - Pressure differential led (optional)
- 6 - 20 µ oil filter
- 7 - Bypass valve (optional)
- 8 - Air / oil heat exchanger
- 9 - Flow switch (optional)



11- Troubleshooting Guide



All the operations below must be done by authorized and skilled mechanic/electrician. Inform YILMAZ REDUKTOR before making any change to the gearbox. Only oil change is allowed to change without information. Do not make anything if you are not sure what you are doing and contact YILMAZ. Any change or operation done without the information of YILMAZ REDUKTOR is in your own risk and responsibility and YILMAZ REDUKTOR does not take any responsibility.

ID	Problem	Observation	Remedy
001	Gearbox Does Not Start Up	You hear no noise and shaft is not turning. You are not using any driver or frequency inverter.	Please Check the voltage supply and frequency of your electric connection. They must be in accordance with the nameplate of the motor. Observe motor manufacturers start up manual. Still does not work go to ID 100
002	Gearbox Does Not Start Up	You hear no noise and shaft is not turning. You are using frequency inverter or driver.	Please observe the frequency inverter/driver manual. Check the motor by supplying direct voltage to see if the problem is on your driver/frequency inverter. Still does not work go to ID 001.
003	Gearbox Does Not Start Up	You hear some noise but both motor shaft and gearbox shaft is not turning. You are not using any driver /frequency inverter or braked motor.	Please Check the voltage supply and frequency of your electric connection. They must be in accordance with the nameplate of the motor. Observe motor manufacturers start up manual. Still same problem, the load may be too high for the chosen motor. Loosen the gearbox from the load/torque. If it works than the starting torque is insufficient and higher motor power is needed. For mono phase motors, check the starting up condensator and running condensator as well. If nothing helps go to ID 100
004	Gearbox Does Not Start Up	You hear some noise but both motor shaft and gearbox shaft is not turning. You are using driver or frequency inverter.	Please observe the frequency inverters or drivers manual. To see if the problem is on your driver or frequency inverter take out the driver/frequency inverter and make direct voltage supply to the motor according the motors nameplate. Still does not work go to ID 100
005	Gearbox Does Not Start Up	You hear some noise but both motor shaft and gearbox shaft is not turning. You are using braked motor	Please Check the voltage supply and frequency of your electric connection. They must be in accordance with the nameplate of the motor. Observe motor manufacturers start up manual. Be sure that the brake is working. Observe the brake manufacturers manuel. If brake is supplied from YILMAZ observe this manuel for correct brake wiring diagram. If still not work supply the brake with voltage according its nameplate directly. For example 198 V DC. You will hear a clicking noise explaining that the brake is opening. If you hear no noise the brake or rectifier is defect. If you hear the clicking noise the brake is working. You should this clicking noise by your normal electric connection as well. By supplying direct supply to the brake you hear the clicking noise and at same time you supply the motor with direct voltage according to its name plate and still same problem, the load may be too high for the chosen motor. Go to ID 003.

Operating Instructions

B Series

Troubleshooting Guide



ID	Problem	Observation	Remedy
006	Gearbox Does Not Work in Low speeds / Frequencies.	You are using frequency inverter.	For very low speeds the frequency inverters frequency is lowering down. For very low frequencies the inverter parameter and motor parameter must be optimise. Also for low speeds the efficiency of the gearbox may vary too much. Specially for worm-gearboxes. The recommended frequency range is 20-70 Hz for worm-gearboxes and 10-70 Hz for Helical Gear Boxes. Use Higher motor power and Frequency inverter or change ratio of gearbox to work inside the recommended range.
007	Gearbox Does Not Start Mornings or After Long Time Stop.	Ambient Temperature is below +5 Celsius	The oil is not in accordance with your working conditions. Change to lower viscosity oils. Observe this manual for using the correct oil. Working in higher ambient temperatures is an other solution if possible. If still same problem you need higher motor power.
008	Gearbox is Heating Up too Much	You are using Worm Gear Box and ambient temperature is lower than +40 Celsius	Measure the surface temp. using a temperature measuring device under full load. If the temp is under +80 Celsius this will make no harm to the gearbox and is normal. All ATEX conforming gearboxes and standard worm gearboxes are designed to work under max. +120 Celsius. <u>If higher than +120 Celsius and using ATEX conforming gear box immediately stop the system and contact YILMAZ REDUKTOR.</u> Go to ID 100. If not ATEX confirming check the oil type and oil quantity/level according your mounting position and check the nameplate mounting position. If nameplate mounting position does not fit the actual position go to ID 100.
009	Gearbox is Heating Up too Much	You are using Helical Gear Box. Ambient temp is lower than +40 Celsius	Measure the surface temp. using a temperature measuring device under full load. If the temp is under +80 Celsius this will make no harm to the gearbox and is normal. All ATEX conforming gearboxes are designed to work under max. +120 Celsius. <u>If higher than +120 Celsius and using ATEX conforming gear box immediately stop the system and contact YILMAZ REDUKTOR.</u> If not ATEX gearbox the gearbox is designed to work under max. +80 Celsius. If higher than +80 Celsius check the oil type and oil quantity/level according your mounting position and check the nameplate mounting position. If nameplate mounting position does not fit the actual position go to ID 100
010	Gearbox is Heating Up too Much	Ambient Temp is over +40 Celsius	Standard Gearboxes are designed to work under +40 Celsius. ambient temperature. If ambient temp is higher than +40 Celsius special solutions/gearboxes are required. Please contact YILMAZ
011	Gearbox is noisy	Noise is regular continuous	Check Your moving parts for noise. Disassemble the gearbox and run without load. If you still hear the noise motor bearings or gearbox bearings are defect. Change bearings. Go to ID 100
012	Gearbox is noisy	Noise is random	Check Your moving parts for noise. Disassemble the gearbox and run without load. If you hear still the noise the oil may has some particles inside. Change the oil and look for small particles. If metal particles are found the gearbox may have some damage. Goto ID 100

Operating Instructions

B Series

Troubleshooting Guide



ID	Problem	Observation	Remedy
013	Gearbox is noisy	Regular knocking noise	Check Your moving parts for noise. Disassemble the gearbox and run without load. If you still hear the noise one of the gears inside is defect. Go to ID 100
014	Gearbox is noisy	Regular up and down noise	Check the output-shaft connection elements for run out. Take out the output shaft element and run without load. If you still hear the noise one of the gears has run out problem. Go to ID 100
015	Gearbox is noisy	Gearbox is with braked motor and noise is coming from the brake side randomly.	Low randomly clicking noise may come from the brake disk which is normal. If noise level is disturbing the brake may be defect or brake clearance is not adjusted. Go to ID 100
016	Gearbox is noisy	You are using frequency inverter and the noise level is changing according your speed.	The frequency inverter parameters are not optimise for the frequency range or motor you are using. Observe the frequency inverters manual. If still same problem change the ratio of gearbox. Go to ID 100
017	Oil is Leaking	Oil Leakage from Seal	If ambient Temp is over +40 Celsius or none stop work over 16 hours please change the top plug with a breather plug. Observe this manual for using breather plug. If this is not your case the seal could be damaged. Go to ID 100
018	Oil is Leaking	Oil Leakage from Plug	If you are using breather plug be sure it is in the correct place. This is the most top plug position according your mounting position. The plug may be not tight enough. There are some particles under the plug rubber surface. Clean and tighten the plug. If still same problem go to ID 100
019	Oil is Leaking	Oil Leakage from Housing	Observe exactly where the oil is coming out. It could be seal or plug point where it comes out and leaks over the housing. If this is your case go to ID 018/019. If you are sure oil comes out from housing than housing has some micro split / crack. Go to ID 100
020	Oil is Leaking	Oil Leakage from Cover	The sealing liquid under cover is split/defect. Disassemble the cover and put new sealing liquid. Assemble the cover and tighten the bolts. If still same problem go to ID 100
021	Gearbox is moving regularly on its mounting point	You are using Torque Arm	The movement of gear box is because of the run out of the shaft which you assemble the gearbox. This has no bad affect or harm to the gearbox and is normal unless you are using torque arm.
022	Gearbox is moving randomly on its mounting point	You are using Torque Arm	The movement of gear box is because of the run out and clearance of the shaft which you assemble the gearbox. Check the clearance of the assembling shaft and the clearances on your machine. This has no bad affect or harm to the gearbox unless you are using torque arm.
023	Motor is heating up	Motor is running over its nominal current	The motor power is not enough or some overload to the motor is possible. The motor may be defect. Go to ID 100
023	Motor is heating up	Ambient is dusty	Check the motor Fan Hub and rips. They must be free of dust. If you are using forced external fan, check if it is working. If you are using frequency inverter in low speeds and you do not have forced external fan, you may need forced external fan. Go to ID 100

Operating Instructions

B Series

Troubleshooting Guide



ID	Problem	Observation	Remedy
024	Motor is running but Gearbox shaft does not turn	Scratching noise comes out	Some part (key, gear) may be defect inside gearbox. Go to ID 10
025	Gearbox Housing is Defect	You are using chain drive or pinion gear	The radial load or polygon effect of the chain may have caused the damage. Check also if the assembly bolts are loosened or the plate you assemble the gearbox is rigid enough. Check if you are using the correct diameter of chain drive and you are not exceeding max. allowed radial load. Check the position of your output element and re-calculate your radial load and check if this fit to the maximum allowed radial load. Go to ID 100
026	Output Shaft is Defect	You are using chain drive or pinion gear	The radial load or polygon effect of the chain may have caused the damage. Check also if the assembly bolts are loosened or the plate you assemble the gearbox is rigid enough. Check if you are using the correct diameter of chain drive and you are not exceeding max. allowed radial load. Check the position of your output element and re-calculate your radial load and check if this fit to the maximum allowed radial load. Go to ID 100
027	Gearbox is stopping too late	You are using braked motor	Please check the wiring diagram of the brake. There are two different kind of brake wiring diagram. The standard gearbox delivered from our factory is set to delayed braking. For sudden braking check the wiring diagram.
028	Gearbox is starting too late	You are using braked motor	For fast opening of big brakes (over 100 Nm), you may need shock transformers which is supplied by YILMAZ. Go to ID 100
100	Service Required	No self solution found	Please contact YILMAZ REDUKTOR Service point. See on the back side of this manual. Changing mechanical parts of gearbox can only be done by YILMAZ REDUKTOR or with information of YILMAZ REDUKTOR. Any change without informing YILMAZ REDUKTOR will cancel the warranty, manufacturer declaration and YILMAZ REDUKTOR will take no responsibility.

12- Disposal

If your product is no longer of use and you wish to dispose it, refer to the instructions here. If you have any questions regarding ecological disposal methods, please consult our service points given on the backside of this manual.

12.1- Disposal of Oil

Lubricants (oil and greases) are hazardous substances, which can contaminate soil and water. Collect drained lubricant into suitable receptacles and dispose of it according to the valid national guidelines.

12.2- Disposal of Sealing

Remove the sealing rings from the gear reducer, and clean them of oil and grease residues. Dispose of the sealing as composite material (metal/plastic)

12.3- Disposal of Metal

Divide up the remainder of the gear reducer into iron, aluminium, non-ferrous heavy metal if possible. Dispose of it according to the valid national guidelines.

Appendix



Warranty Conditions:

1. The geared motors and gear units are warranted for two year except the electric motor. For motor warranty please refer to the manual of the electric motor manufacturer or the warranty document of the motor manufacturer. This warranty is valid only if the gearbox is assembled and started up according our operating instructions and is used under the allowed conditions for the appropriate gearbox type in our catalogue. Special Gearbox parts made according customer request are not covered by this warranty.
2. The warranty time starts from the start up time written on the warranty document and last for two years. If the start-up time is more then three months after the billing time, the total warranty time is limited to 27 months starting from billing time. If the warranty document is not send to our company after start-up, the total warranty time will be limited to 24 months after the billing time.
3. Any time during the warranty for maintenance, repair or change will be added to the warranty time. This time starts from the date which the company or representative was made aware of the problem and ends on the date of the re-start-up.
4. If the product fails to operate because of a manufacturing or assembly failure during the warranty time, the product will be repaired free of charge.
5. If the product fails to operate because of a manufacturing or assembly failure during the warranty time and it is not possible to repair it, the product will be changed with a new one according to the report from our service department mentioning that the hazard can not be repaired.
6. Costumers must inform the manufacturer if there are some problems after the service and repair of the failed product.
7. The extra costs like stopped plant, physical or mental injuries etc. by the costumer side are not covered by this warranty except the product itself.

YILMAZ REDUKTOR San. ve Tic. A.S.

Head Office: Maltepe Gumussuyu Cad. Bestekar Medeni Aziz Efendi Sok. No:54

P.K.34020 Topkapi/Istanbul-TURKEY

Phone: +90 (0) 212 567 93 82/83 , Fax: +90 (0) 212 567 99 75

Factory : YILMAZ REDUKTOR Sanayi ve Ticaret A.S.

ATATÜRK Mah. Lozan Cad. No:17 P.K.34522 Esenyurt-İstanbul- TURKİYE

Telephone: +90 (0) 212 886 90 01 (8 line) , Fax: +90 (0) 212 886 54 57



Warranty Decleration and Instruction Manual Receipt Form

YILMAZ REDUKTOR products are warranted for **2 (Two)** years covering all parts and materials used in products and their production errors unless they are started-up and used according our service manual and is not modified or disassembled without an acknowledgement from our company.

The warranty covers all costs like repair, service, spare parts etc. and no charge will be asked under any name. The time for repair, service will be added to the warranty time.

For detailed warranty conditions please refer the back side of this page.

Serial No:

Type:

Manufacturer:

Company : YILMAZ REDUKTOR Sanayi ve Ticaret A.S.

Address : ATATÜRK Mah. Lozan Cad. No:17 P.K.34522 Esenyurt-Istanbul- TURKIYE

Telephone : +90 (0) 212 886 90 01 (8 line)

Fax : +90 (0) 212 886 54 57

Stamp and Signature

Supplier / End User:

With signing this part and sending this back to our company your warranty period will be started and you are accepting that you have received the operating instruction of the product.

Name:

Billing Date/ Bill No.:

Start-Up Place / Date:

Address:

Phone - Fax:

Supplier/ End User Stamp and Signature

Service Contact Points:

Main Service Point:

YILMAZ REDUKTOR A.S.

ATATÜRK Mah. Lozan Cad. No:17 P.K.34522 Esenyurt-Istanbul- TÜRKİYE

Telephone: +90 (0) 212 886 90 01 - 6 lines , Fax: +90 (0) 212 886 54 57

Head Office:

Tel: +90 (0)212 567 93 82 (2 line),

+90(0) 212 567 06 03,

+90(0) 212 567 40 78

+90(0) 212 567 04 11

+90(0) 212 567 45 07

+90(0) 212 567 00 70

Fax: +90(0) 212 567 99 75

e-mail: yilmaz@yr.com.tr

web: www.yr.com.tr

Factory:

Tel: +90(0) 212 886 90 01 (8 line)

+90(0) 212 886 50 43

+90(0) 212 886 50 44

+90(0) 212 886 52 82

Fax: +90 (0) 212 886 54 57

e-mail: yilmaz@yr.com.tr

web: www.yr.com.tr

Outside Turkey:

Please contact the main service point mentioned above. You will be directed to our nearest service point to your location