

AquaTRUE™ Planetary Gearheads

Mounting Configurations & Instructions

P-3061-BG
86-121-055, Issue 6



Mounting Configuration #1 (Round Motor)

Note: Washdown of gearhead while the output shaft is turning may cause seal leakage and permanent damage to gearhead

STEP 1: Lay the gearbox (Item 1) on a work surface and wipe any dirt or dust particles on the face (Item 2) away using forced dry air or rubbing alcohol.

STEP 2: Set the motor (Item 4) on the work surface vertically with the output shaft facing straight up. Clean the mounting face of the motor of any dirt or dust particles, in the same fashion as STEP 1.

STEP 3: Lube oring (Item 3) with the oring lubricant provided (use only minimal amount to assist oring in sticking into the motor groove). Assemble the oring into the motor groove, making sure that it is evenly seated all away around the groove.

STEP 4: Slide the gearbox with the hub clamp (Item 6) down onto the motor shaft.

STEP 5: Tighten the hub screws (Item 8) to the specified pre-tightening torque (see table 1 on page 5). The hub screws can be accessed through the access holes in the gearbox housing (Item 1).

STEP 6: Insert and tighten the four hexhead screws (Item 5) provided to secure the motor to the gearbox finger tight.

STEP 7: Loosen the hub screws (Item 8).

STEP 8: Tighten the four hexhead screws (Item 5) to the specified full torque (see table 2 on page 5). Torque to be applied in the proper alternating cross pattern for four screws.

STEP 9: Fully tighten the hub screws to their final tightening torque specification (see table 1 on page 5), gradually increasing the torque value in at least 3 increments and in an alternating fashion.

STEP 10: Plug both hub access holes with the provided hex plugs (Item 7). Tighten both to the recommended torque (see table 3 on page 5).

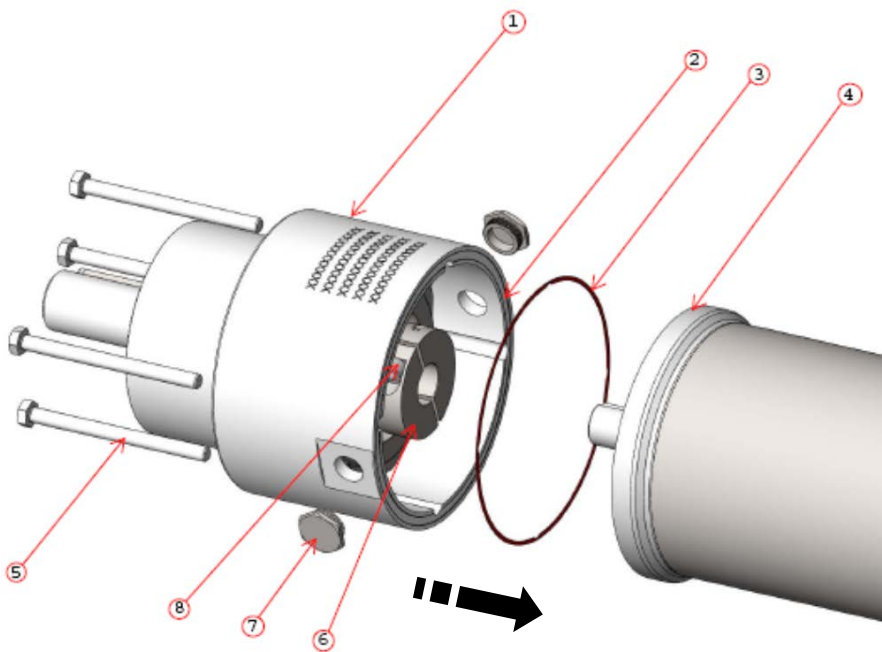

Note: Appearance of parts may vary

NOTE: Motor O-ring or Gasket (item 3) **MUST** be replaced and lubricated every time the gearhead is disassembled from the motor.

Mounting Configuration #2 (Square Motor)

STEP 1: Lay the gearbox (Item 1) on a work surface and wipe any dirt or dust particles on the face (Item 2) away using forced dry air or rubbing alcohol.

STEP 2: Set the motor (Item 4) on the work surface vertically with the output shaft facing straight up. Clean the mounting face of the motor of any dirt or dust particles, in the same fashion as STEP 1.

STEP 3: Lube gasket (Item 3) with the gasketing compound provided (use only minimal amount to assist O-ring in sticking into the gearbox groove). Assemble the gasket into the groove, aligning the notches (if present) in the groove with the hole pattern in the gearbox housing and making sure that it is evenly seated all away around the groove.

STEP 4: Slide the gearbox with the hub clamp (Item 6) down onto the motor shaft.

STEP 5: Tighten the hub screws (Item 8) to the specified pre-tightening torque (see table 1 on page 5). The hub screws can be accessed through the access holes in the gearbox housing (Item 1).

STEP 6: Insert and tighten the four hexhead screws (Item 5) provided to secure the motor to the gearbox finger tight.

STEP 7: Loosen the hub screws (Item 8).

STEP 8: Tighten the four hexhead screws (Item 5) to the specified full torque (see table 2 on page 5). Torque to be applied in the proper alternating cross pattern for four screws.

STEP 9: Fully tighten the hub screws to their final tightening torque specification (see table 1 on page 5), gradually increasing the torque value in at least 3 increments and in an alternating fashion.

STEP 10: Plug both hub access holes with the provided hex plugs (Item 7). Tighten both to the recommended torque (see table 3 on page 5).

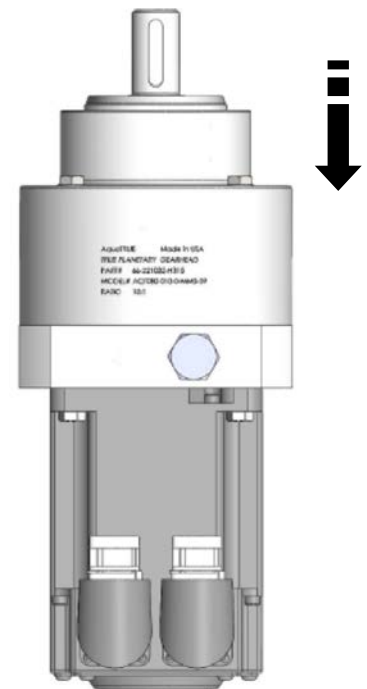
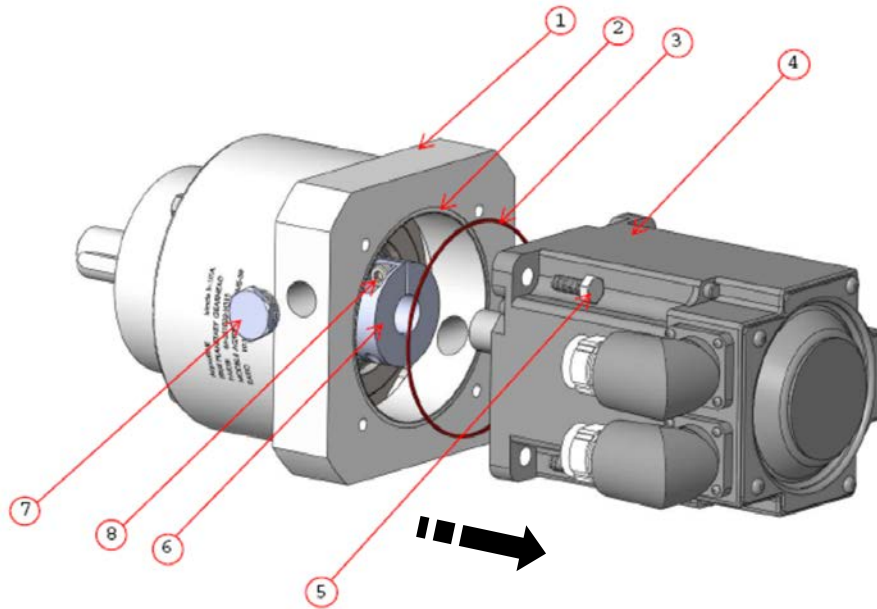

Note: Appearance of parts may vary

NOTE: Motor O-ring or Gasket (item 3) MUST be replaced and lubricated every time the gearhead is disassembled from the motor.

Mounting Configuration #3 (Special Round Motor)

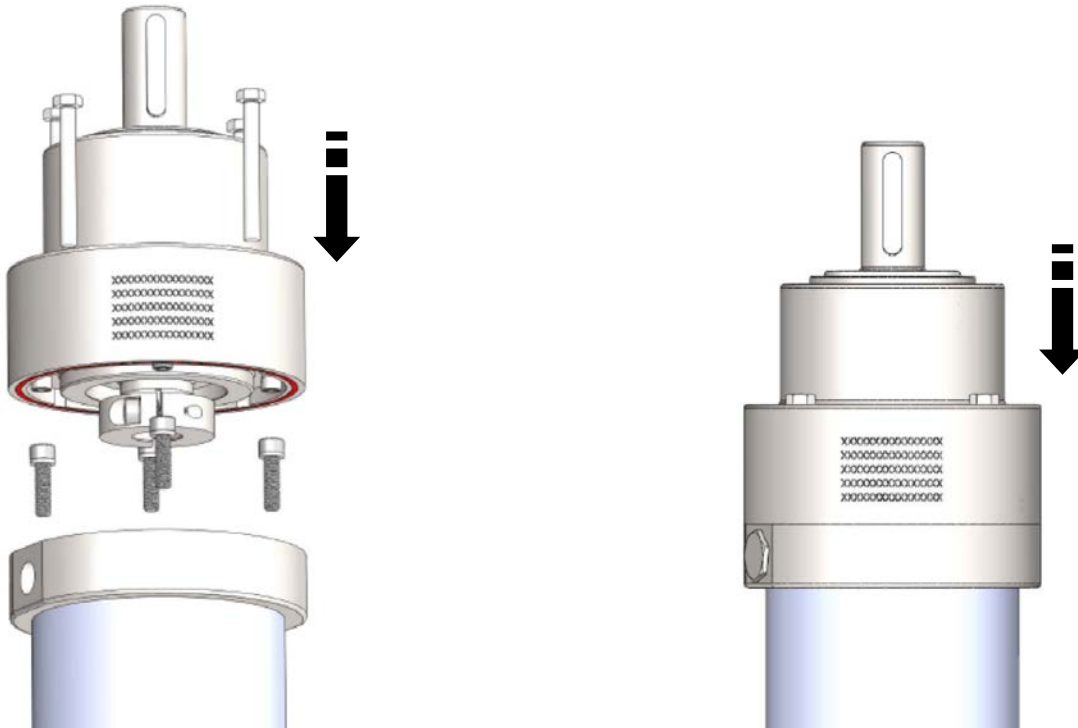
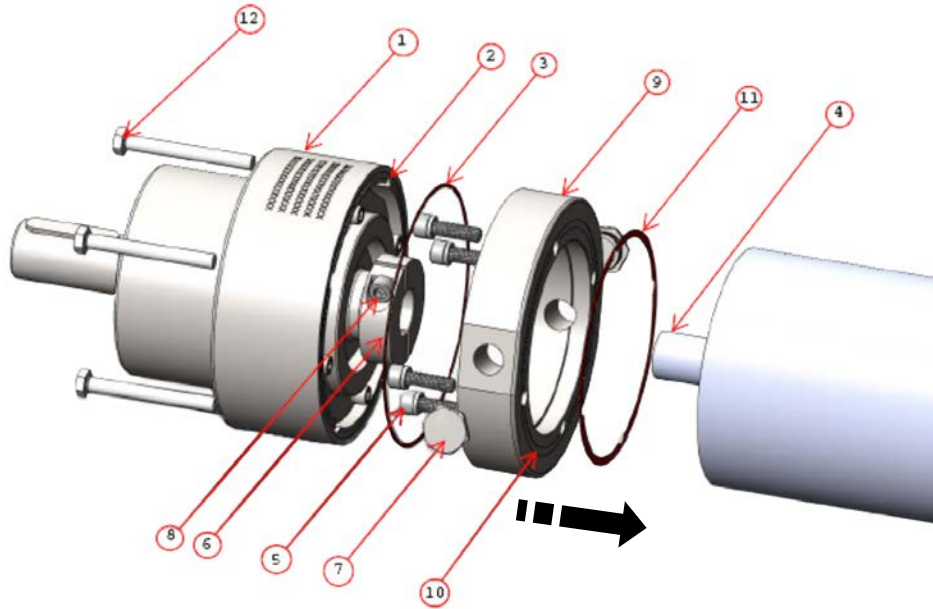

Note: Appearance of parts may vary

Mounting Configuration #3 (Cont...)

STEP 1: Wipe any dirt or dust particles in the groove (Item 10) of the adapter plate (Item 9) and surrounding mounting face using forced dry air or by rubbing alcohol. Lube gasket (Item 11) with the gasketing compound provided (use only minimal amount to assist gasket in sticking into groove). Assemble the gasket into the groove, aligning the notches (if present) in the groove with the hole pattern in the adapter plate.

STEP 2: Set the motor (Item 4) on the work surface with the output shaft facing straight up (remove key from the shaft, if present). Clean the mounting face of the motor of any dirt or dust particles. Mate the adapter plate with the assembled gasket onto the motor face using the four screws (Item 5) and associated lockwashers provided, using their recommended tightening torque specification (see specific gearbox control drawing for screw size and material).

STEP 3: Lay the gearbox (Item 1) on a work surface and wipe any dirt or dust particles on the face (Item 2) and surrounding mounting face away using forced dry air or rubbing alcohol.

STEP 4: Lube gasket (Item 3) with the gasketing compound provided (use only minimal amount to assist O-ring in sticking into the gearbox groove). Assemble the gasket into the groove, aligning the notches (if present) in the groove with the hole pattern in the gearbox housing and making sure that it is evenly seated all away around the groove.

STEP 5: Slide the gearbox with the hub clamp (Item 6) down onto the motor shaft.

STEP 6: Tighten the hub screws (Item 8) to the specified pre-tightening torque (see table 1). The hub screws can be accessed through the access holes in the gearbox housing (Item 1).

STEP 7: Insert and tighten the four hexhead screws (Item 5) provided to secure the motor to the gearbox finger tight.

STEP 8: Loosen the hub screws (Item 8).

STEP 9: Tighten the four hexhead screws (Item 5) to the specified full torque (see table 2). Torque to be applied in the proper alternating cross pattern for four screws.

STEP 10: Fully tighten the hub screws to their final tightening torque specification (see table 1), gradually increasing the torque value in at least 3 increments and in an alternating fashion.

STEP 11: Plug both hub access holes with the provided hex plugs (Item 7). Tighten both to the recommended torque (see table 3).

Tightening Torque Tables

Table 1

Hub Tightening Torques				
GB Size	Pre-tightening Torque		Final Tightening Torque	
	in-lb	Nm	in-lb	Nm
AQT080	4	0,4	76	8,5
AQT120	16	1,8	316	36
AQT160	32	3,6	636	72

Table 2

Gearbox Screw Tightening Torque		
GB Size	Tightening Torque	
	in-lb	Nm
AQT060	22	2,5
AQT080	76	8,5
AQT120	187	21
AQT160	372	42

Table 3

Hub Access Plug Tightening Torque		
GB Size	Tightening Torque	
	in-lb	Nm
AQT060	55.3	6,3
AQT080	55.3	6,3
AQT120	55.3	6,3
AQT160	88.5	10

NOTE: Motor O-ring or Gasket (item 3) MUST be replaced and lubricated every time the gearhead is disassembled from the motor.

Micron Warranty

Boston Gear warrants that products manufactured or sold by it shall be free from defects in material and workmanship. Micron gearhead products which shall within one (1) year of delivery, be proved to the Company's satisfaction to have been defective at the time of delivery in these respects will be replaced or repaired by the Company at its option. Freight is the responsibility of the customer. The Company's liability under this limited warranty is limited to such replacement or repair and it shall not be held liable in any form of action for direct or consequential damages to property or person. THE FOREGOING LIMITED WARRANTY IS EXPRESSLY MADE IN LIEU OF ALL OTHER WARRANTIES WHATSOEVER, EXPRESS, IMPLIED AND STATUTORY AND INCLUDING WITHOUT LIMITATION THE IMPLIED WARRANTIES OF MERCHANTABILITY AND FITNESS.

No employee, agent, distributor, or other person is authorized to give additional warranties on behalf of Boston Gear, nor to assume for Boston Gear any other liability in connection with any of its products, except an officer of Boston Gear by a signed writing.



www.bostongear.com

701 Carrier Drive
Charlotte, NC 28216
704-588-5610