



# Operation Manual RTM MP

## EMGZ482T.MP.24VDC, EMGZ482R.MP and EMGZ443MP.T, EMGZ443MP.R

### Multi-Purpose Radio Transmission Tension Monitoring System with Encoder Signal Evaluation

Version 3.07      12/2014      ff  
Firmware Version: V 3.03

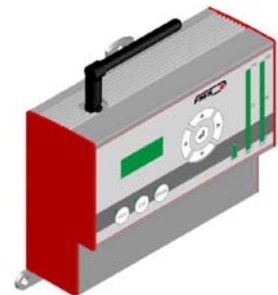

This operation manual is also available in German.  
Please contact your local FMS representative.

Diese Bedienungsanleitung ist auch in Deutsch erhältlich.  
Bitte kontaktieren Sie Ihren nächstgelegenen FMS Vertreter.

## Table of Contents

---

<b>1</b>	<b>Safety Instructions .....</b>	<b>3</b>
1.1	Description conditions	3
1.2	List of Safety Instructions	4
<b>2</b>	<b>System Description .....</b>	<b>5</b>
2.1	Functional Description RTM MP System	5
2.2	System Components	6
<b>3</b>	<b>Certifications and Compliancy.....</b>	<b>7</b>
<b>4</b>	<b>Installation and Wiring .....</b>	<b>9</b>
4.1	Area of Machine Rotation	9
4.2	Force Measuring Sensors on the Static Machine Area	9
4.3	Force Measuring Sensors on a Rotating Machine Part	9
4.4	Mounting and Wiring the Electronic Components	10
4.5	Mounting and Wiring the Transmitter EMGZ482T.MP.24VDC	11
4.6	Components on the Static Part of the Machine	12
4.7	Wiring the Receiver EMGZ482R.MP	13
4.8	In- and Output Schematics EMGZ443MP.T and R	14
4.9	Connectors EMGZ443MP.T (rotating machine part)	15
4.10	Connectors EMGZ443.MP.R (static machine part)	17
<b>5</b>	<b>Configuration of the RTM MP System .....</b>	<b>19</b>
5.1	RTM MP Quick Start	19
5.2	Description of the Operating Panel EMGZ482R.MP	19
5.3	Offset Compensation Procedure	20
5.4	Calibration Methods	21
5.5	Calibration Procedure	21
5.6	Relay Output for Lost Communication	21
<b>6</b>	<b>Mechanical Dimensions .....</b>	<b>22</b>
<b>7</b>	<b>Trouble Shooting.....</b>	<b>24</b>
<b>8</b>	<b>Technical Data .....</b>	<b>25</b>

# 1 Safety Instructions

All safety related regulations, local codes and instructions that appear in the manual or on equipment must be observed to ensure personal safety and to prevent damage to the equipment connected to it. If equipment is used in a manner not specified by the manufacturer, the protection provided by the equipment may be impaired. Do not stress the equipment over the specification limits neither during assembly nor operation. To do so can be potentially harmful to persons or equipment in the event of a fault to the equipment.

## 1.1 Description conditions

### a) Danger of health injury or loss of life



#### **Danger**

*This symbol refers to high risk for persons to get health injury or loss life. It has to be followed strictly.*

### b) Risk of damage of machines



#### **Caution**

*This symbol refers to information, that if ignored, could cause heavy mechanical damage. This warning has to be followed absolutely.*

### c) Note for proper function



#### **Note**

*This symbol refers to an important information about proper use. If not followed, malfunction can be the result.*

## 1.2 List of Safety Instructions

- ⚠** *Changes or modifications made to this equipment not expressly approved by (manufacturer name) may void the FCC authorization to operate this equipment.*
- ⚠** *This device complies with Part 15 of the FCC Rules and with Industry Canada licence-exempt RSS standard(s). Operation is subject to the following two conditions:  
(1) this device may not cause harmful interference, and  
(2) this device must accept any interference received, including interference that may cause undesired operation.*
- ⚠** *Radiofrequency radiation exposure Information.  
This equipment complies with FCC radiation exposure limits set forth for an uncontrolled environment. This equipment should be installed and operated with minimum distance of 20 cm between the radiator and your body: This transmitter must not be co-located or operating in conjunction with any other antenna or transmitter.*
- ⚠** *It is of paramount importance to compensate the centrifugal forces caused by the rotating base plate of the stranding machine. The measuring results will be wrong, if this rule is broken.*
- ⚠** *Proper function of the FMS RTM MP System can only be guaranteed with the recommended application of the components. Other arrangements can cause malfunctions. Therefore, the installation instructions on the following pages must be followed.*
- ⚠** *Local installation regulations are to preserve safety of electric equipment. They are not taken into consideration by this operating manual. However, they have to be followed strictly.*
- ⚠** *The shield should be connected only to the electronic unit. On the force sensor side the shield should stay open.*
- ⚠** *Bad earth ground connection may cause electric shock to persons, malfunction of the total system or damage of the electronic unit! It is vital to ensure that proper earth connection is done.*
- ⚠** *The sensor cables must be installed separate from power lines.*

## 2 System Description

### 2.1 Functional Description RTM MP System

RTM MP is an innovative system that utilizes force measuring rollers to capture the tension of individual wires or strands, and then securely transmits this data from the rotating to the static part of the machine. Channel Extension Modules expand the system with a variety of analogue and digital I/Os and thus create the multi-channel, multi-purpose system RTM MP

The expansion module EMGZ443MP.T is used in the transmitter side (rotating part of the machine). The EMGZ443MP.R expands the system on the receiver side (static part of the machine). A fully expanded system can handle 2 force measuring rollers, 4 Encoders, 2 analogue I/Os and 16 digital I/Os. In addition a relay contact is activated if the radio link is interrupted. The expansion achieved in this way allows a versatile operation of the system.

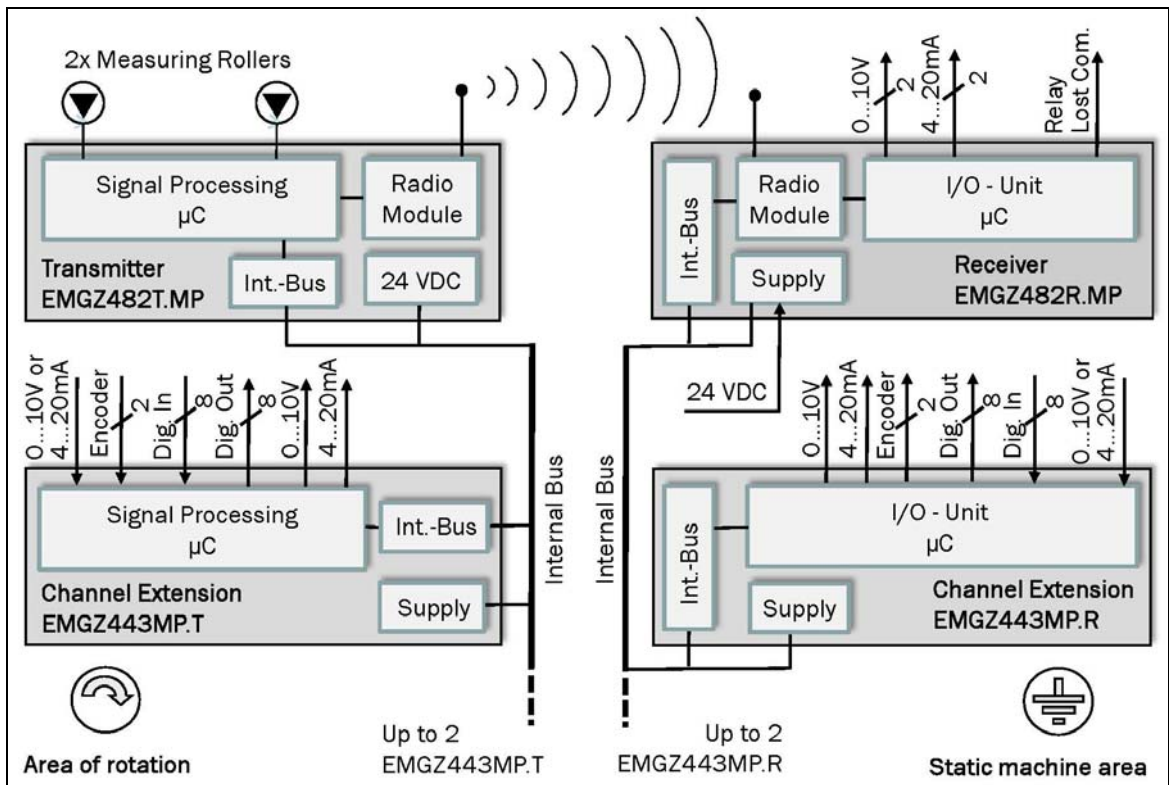

Fig. 1: Block diagram of RTM MP -System

RTM-MP0010e

## 2.2 System Components

### RMGZ Force Measuring Rollers

- Measures the wire tension
- Converts the tension values in an electrical signal



### EMGZ482T.MP.24VDC

- Amplification and conditioning of the electrical signals
- Wireless transmission of tension data
- Bus connection to EMGZ443MP.T
- Power supply via slip rings



### EMGZ482R.MP

- Wireless reception of tension data
- Offset compensation
- Bus connection to EMGZ443MP.R
- Data transfer to EMGZ443MP.R and PLC.

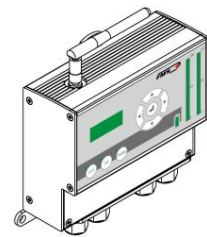

### EMGZ443MP.T Extension Module Multi-Purpose Transmitter Side

- Expansion of I/O Configuration by:
  - 1x Analogue output 0...10V or 4...20mA
  - 1x Analogue input 0...10V or 4...20mA
  - 2x Encoder Inputs
  - 8x Dig. outputs
  - 8x Dig. inputs

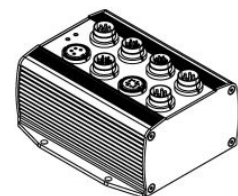

### EMGZ443MP.R Extension Module Multi-Purpose Receiver Side

- Expansion of I/O Configuration by:
  - 1x Analogue output 0...10V or 4...20mA
  - 1x Analogue input 0...10V or 4...20mA
  - 2x Encoder outputs
  - 8x Dig. outputs
  - 8x Dig. inputs

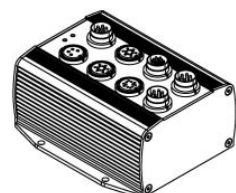

### 3 Certifications and Compliancy

This equipment has been tested and found to comply with following rules:

<b>ETSI Radio Certification</b>	
Magnitude of Test (Coverage)	Article 3.2 of Directive 1999/5/EC (R&TTE Directive)
Certification	ETSI EN 300 440-2 V1.5.1 (2009-03) ETSI EN 300 440-1 V1.3.1 (2009-03)
<b>ETSI EMC Certification</b>	
Magnitude of Test (Coverage)	ECM-Test according to 98/37/EC and 2004/108/EC harmonized
Emission and Immunity Test	ETSI EN 489-3 EN 61326-1
<b>FCC Certification</b>	
Magnitude of Test	Class A digital device, pursuant to Part 15 of the FCC Rules
Certification	FCC Registration #: 0020311882



**Note**

*This equipment has been tested and found to comply with the limits for a Class A digital device, pursuant to Part 15 of the FCC Rules. These limits are designed to provide reasonable protection against harmful interference when the equipment is operated in a commercial environment. This equipment generates, uses, and can radiate radio frequency energy and, if not installed and used in accordance with the instruction manual, may cause harmful interference to radio communications. Operation of this equipment in a residential area is likely to cause harmful interference in which case the user will be required to correct the interference at his own expense.*



**Caution**

*Changes or modifications made to this equipment not expressly approved by (manufacturer name) may void the FCC authorization to operate this equipment.*



**Caution**

*This device complies with Part 15 of the FCC Rules and with Industry Canada licence-exempt RSS standard(s). Operation is subject to the following two conditions:*

- (1) this device may not cause harmful interference, and*
- (2) this device must accept any interference received, including interference that may cause undesired operation*



**Caution**

*Radiofrequency radiation exposure Information.*

*This equipment complies with FCC radiation exposure limits set forth for an uncontrolled environment. This equipment should be installed and operated with minimum distance of 20 cm between the radiator and your body:*

*This transmitter must not be co-located or operating in conjunction with any other antenna or transmitter.*



## 4 Installation and Wiring

### 4.1 Area of Machine Rotation

Following RTM MP components are installed either on the rotating part of the machine or in the area of machine rotation:

- RMGZ Force Measuring Rollers
- Transmitter EMGZ482T.MP.24VDC
- Multi-purpose extension module EMGZ443MP.T

### 4.2 Force Measuring Sensors on the Static Machine Area

The red point should always be aligned in the direction of the resulting Force (see Fig. 2). For further mounting information please consult the respective installation manual of the sensor. The installation manual is always delivered together with the sensor.

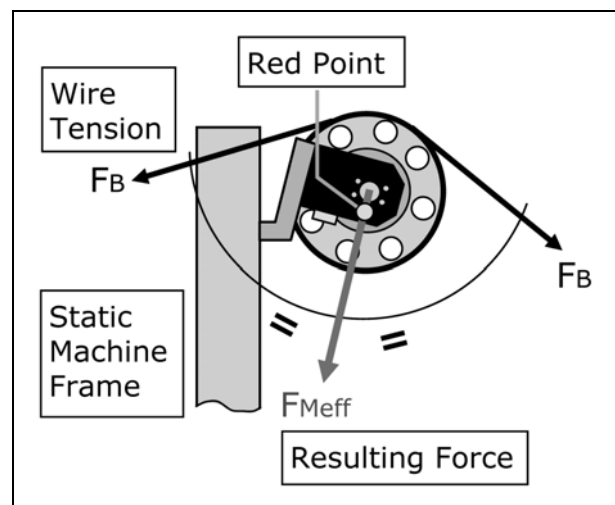

Fig. 2: RMGZ Red Point alignment on static machine parts  
RTMX2 0028e

### 4.3 Force Measuring Sensors on a Rotating Machine Part



#### Note

*In rotating applications the force measuring sensors are mounted such that centrifugal forces are compensated. If using FMS RMGZ sensors, this can be achieved by turning the Red Point parallel to the rotation axis and in direction of the positive force component (refer to Fig. 3).*



#### Note

*The adjustment of the red point can be tested after offset compensation and calibration. If the reading of an unloaded load cell stays at zero regardless of the load cell position (e.g. at 12 o'clock or at 6 o'clock position), the red point is correctly aligned.*

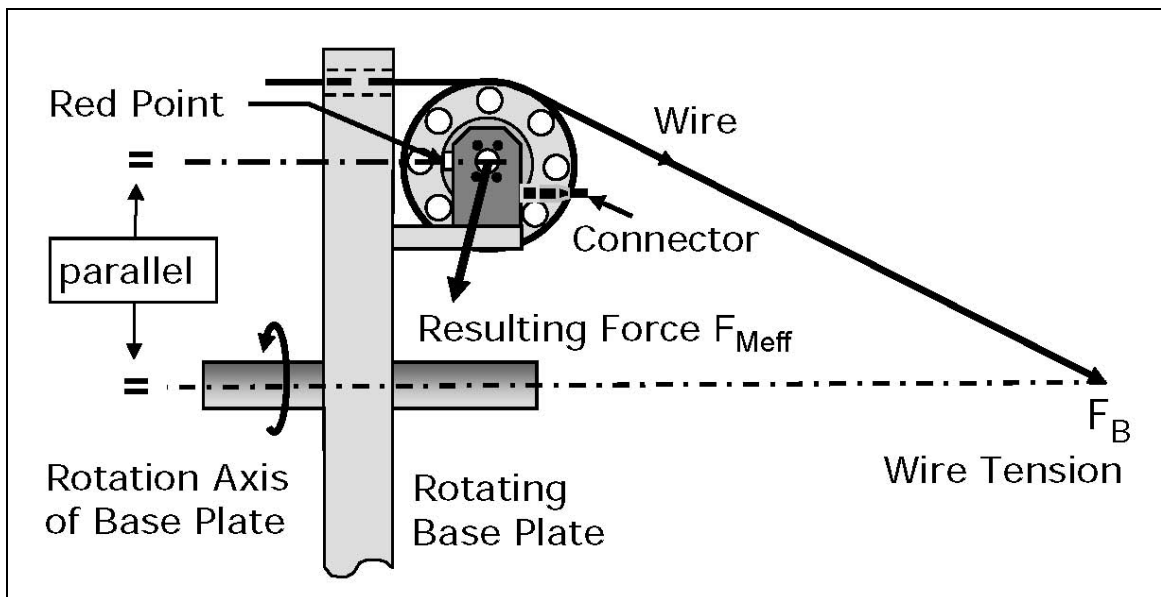

Fig. 3: RMGZ Red Point alignment on rotating machine parts

R300003e

**Caution**  
*It is of paramount importance to compensate the centrifugal forces caused by the rotating base plate of the stranding machine. The measuring results will be wrong, if this rule is broken.*

#### 4.4 Mounting and Wiring the Electronic Components

An RTM MP system is usually delivered complete with all its components and cables. The cables are prepared with connectors on both sides for easy assembly

**Caution**  
*Proper function of the FMS RTM MP System can only be guaranteed with the recommended application of the components. Other arrangements can cause malfunctions. Therefore, the installation instructions on the following pages must be followed.*

**Caution**  
*Local installation regulations are to preserve safety of electric equipment. They are not taken into consideration by this operating manual. However, they have to be followed strictly.*

### 4.5 Mounting and Wiring the Transmitter EMGZ482T.MP.24VDC

One or two force sensors can be connected to the RTM-Transmitter. It is favourably to mount the EMGZ482T.MP.24VDC transmitter close to the RMGZ load cells to keep the signal cables short.

If no standard FMS cables are used, the connection between force sensors and transmitter must be wired with 2x2x0.25mm<sup>2</sup> [AWG 23] shielded twisted-pair cable. The wiring diagram below (Fig. 4) shows how the signals are wired to the connectors.

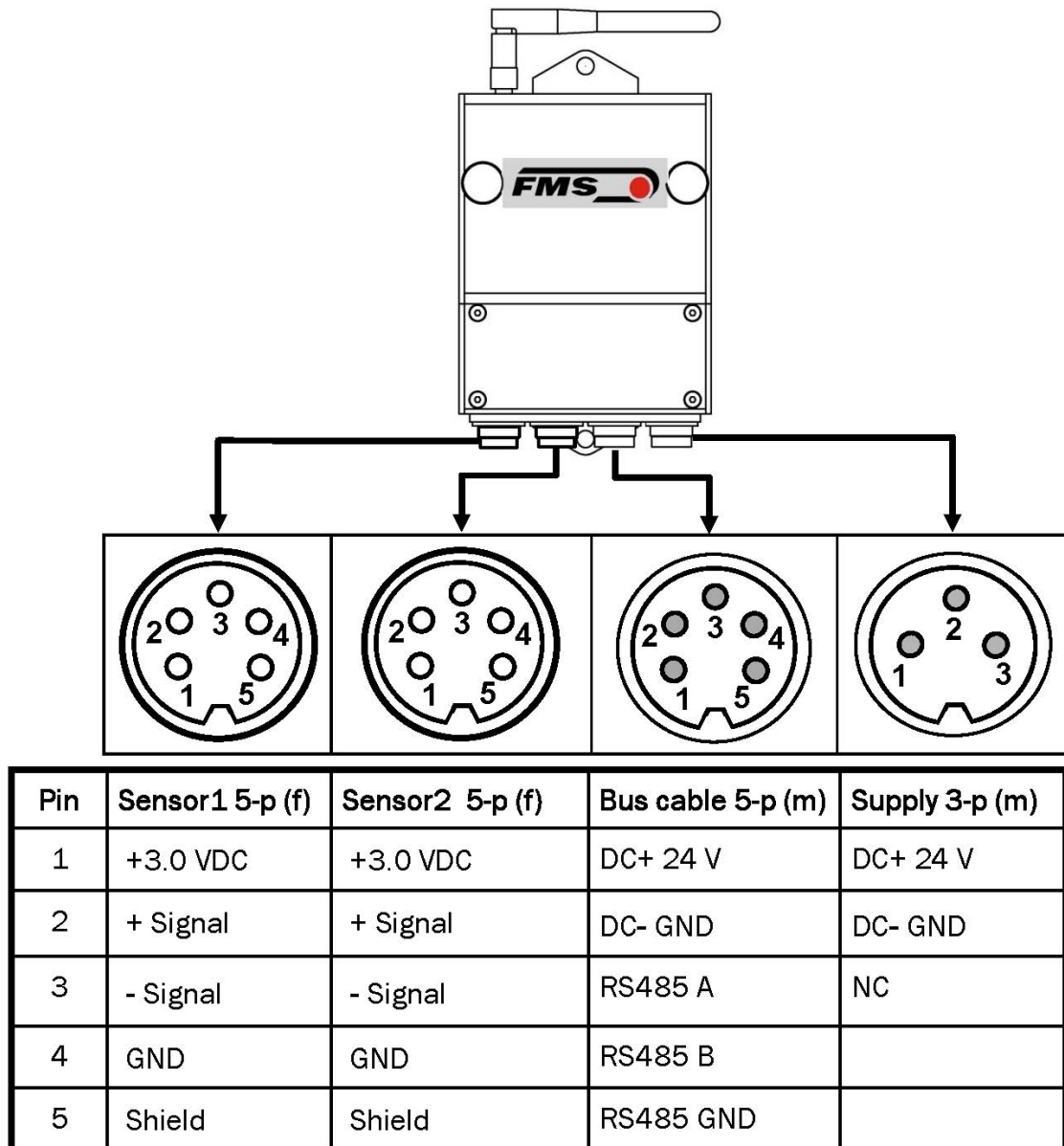

**Fig. 4:** Signal assignment EMGZ482T.MP  
Connectors are shown from the mating side.

RTM-MP007e

**Caution**

*The shield should be connected only to the electronic unit. On the force sensor side the shield should stay open.*

**Caution**

*Bad earth ground connection may cause electric shock to persons, malfunction of the total system or damage of the electronic unit! It is vital to ensure that proper earth connection is done.*

**Caution**

*The sensor cables must be installed separate from power lines.*

## 4.6 Components on the Static Part of the Machine

Following RTM MP components are installed on the static part of the system:

- Receiver EMGZ482R.MP
- Multi-purpose extension module EMGZ443MP.R
- Cables to PLC / Machine Control

### 4.7 Wiring the Receiver EMGZ482R.MP

EMGZ482R.MP receives the data captured by the RTM-transmitter and acts as an interface to a PLC or to a close-loop tension controller. Fig. 6 shows the pin assignment on the electronic board.

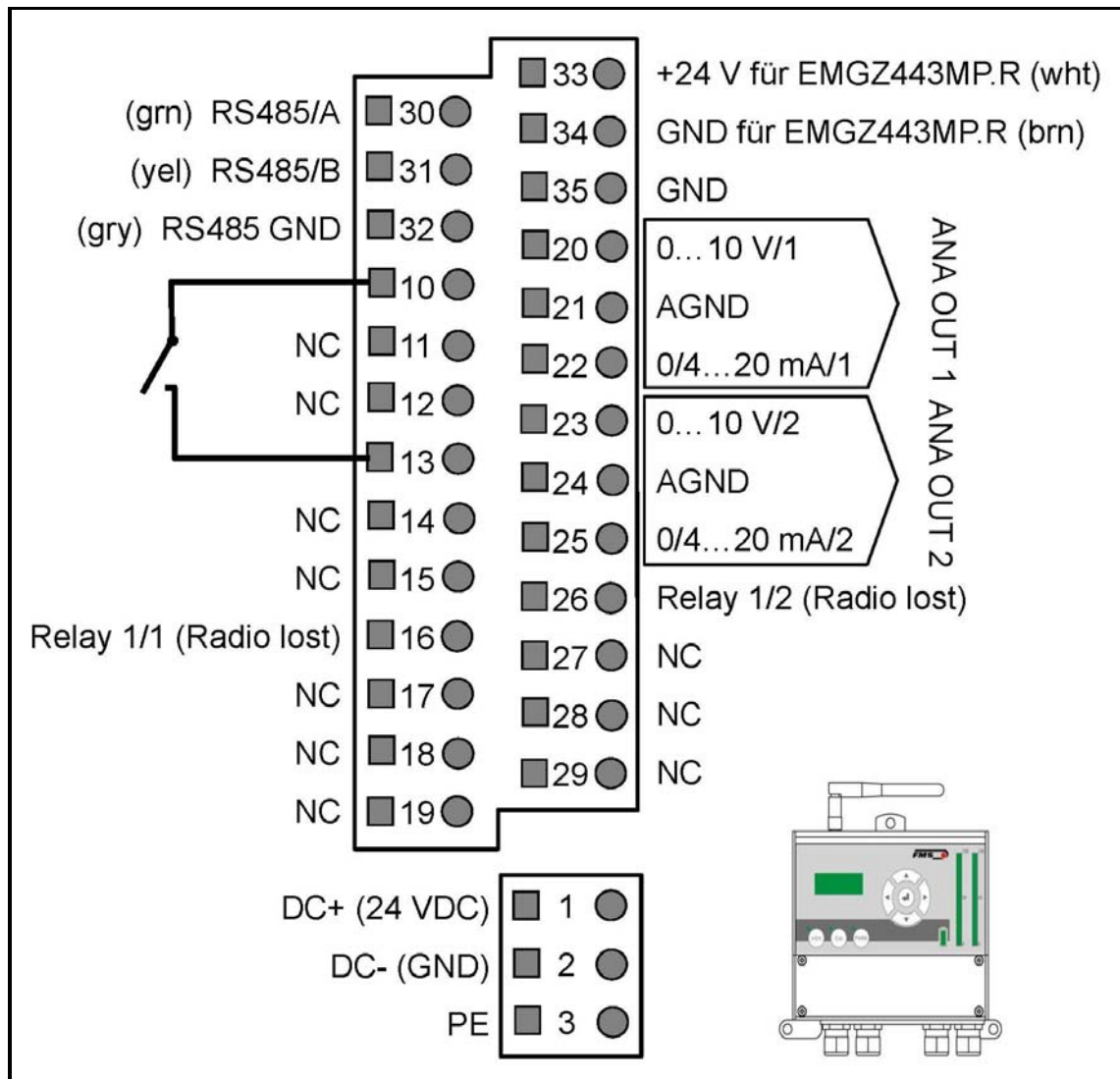

Fig. 6: Signal assignment EMGZ482R.MP on electronic board

RTM-MP008e

### 4.8 In- and Output Schematics EMGZ443MP.T and R

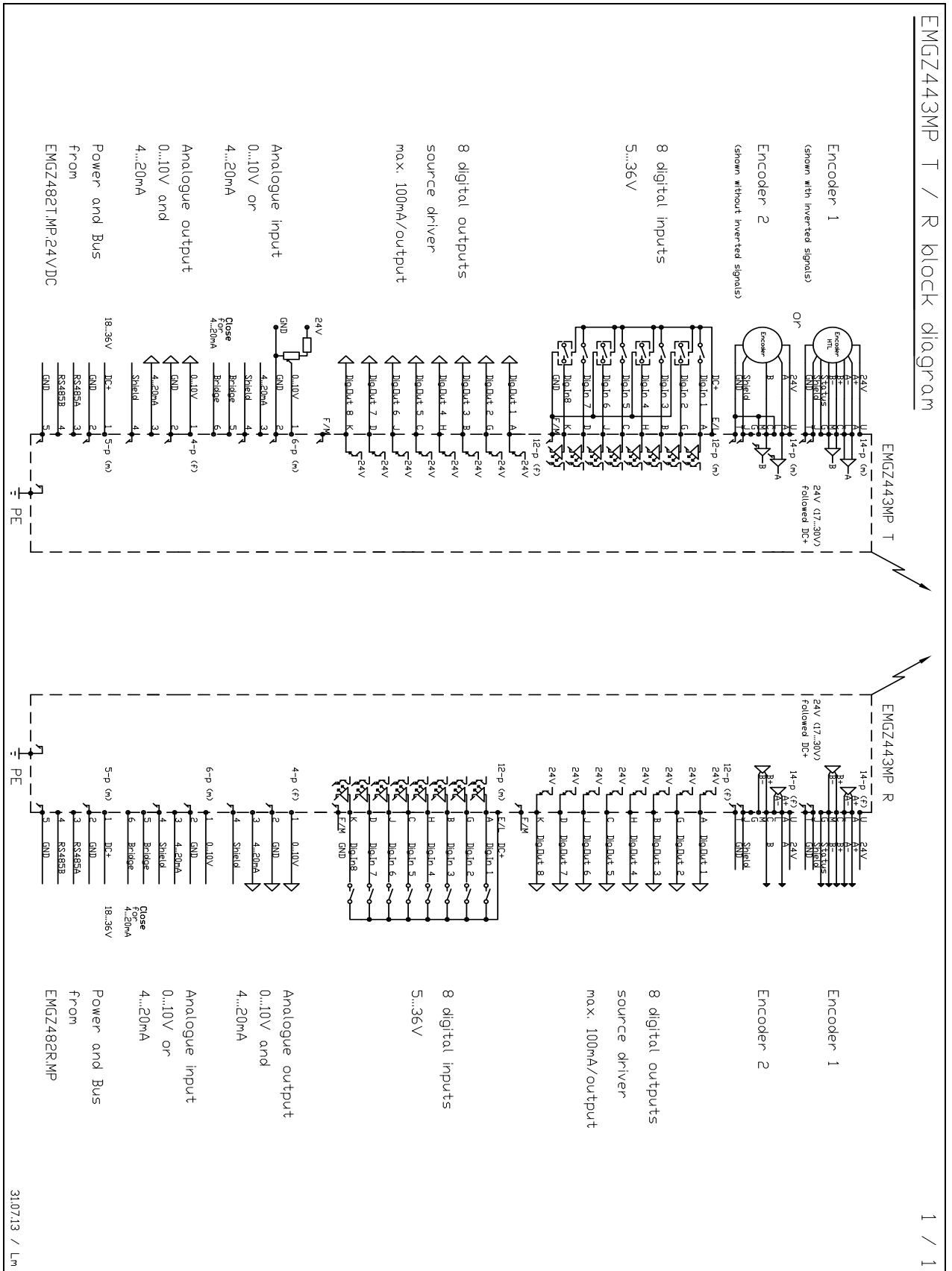
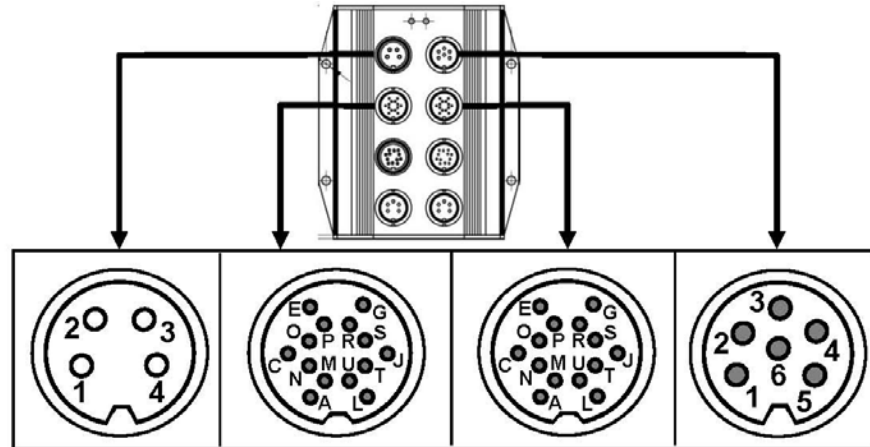

Fig. 7: In / Output configuration EMGZ443MP.T and R

RTM-MP0011e

### 4.9 Connectors EMGZ443MP.T (rotating machine part)



Pin	Colour	Ana Out 4-p (f)	Enco 1 14-p (m)	Enco 2 14-p (m)	Ana In 6-p (m)	
1	A	white	0...10 VDC	A+	A+	0...10 VDC
2	C	brown	AGND	B+	B+	AGND
3	E	green	4...20 mA	Ref+ (inactive)	Ref+ (inactive)	-4...20 mA
4	G	yellow	Shield	Status	Status	Shield
5	J	grey		Shield	Shield	Bridge
6	L	pink		A-	A-	Bridge
	M	blue		B-	B-	
	N			NC	NC	
	O			NC	NC	
	P			NC	NC	
	R			NC	NC	
	S	red		Ref- (inactive)	Ref- (inactive)	
	T	black		GND	GND	
	U	purple		24 V ENC	24 V ENC	

Fig. 8: Signal assignment EMGZ443MP.T (1<sup>st</sup> part))

RTM-MP 003e

Connectors are shown from the mating side.

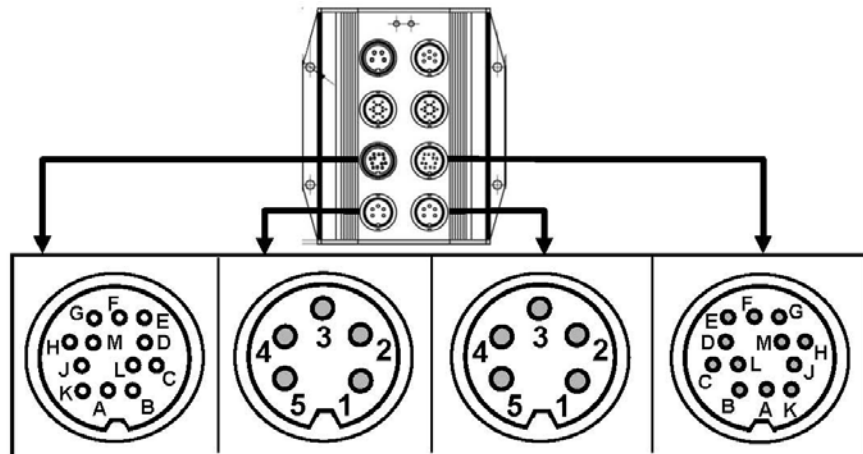

Pin	Colour	Dig. Out 12-p (f)	Power & Bus 5-p (m)	Power & Bus 5-p (m)	Dig. In 12-p (m)	
1	A	white	Dig. Out 1	24 VDC	24 VDC	Dig. In 1
2	B	brown	Dig. Out 3	PGND	PGND	Dig. In 3
3	C	green	Dig. Out 5	RS485 A	RS485 A	Dig. In 5
4	D	yellow	Dig. Out 7	RS485 B	RS485 B	Dig. In 7
5	E	grey	24 VDC	GND	GND	24 VDC
	F	pink	PGND			PGND
	G	blue	Dig. Out 2			Dig. In 2
	H	red	Dig. Out 4			Dig. In 4
	J	black	Dig. Out 6			Dig. In 6
	K	purple	Dig. Out 8			Dig. In 8
	L	gry/pin	24 VDC			24 VDC
	M	red/blu	PGND			PGND

Fig. 9: Signal assignment EMGZ443MP.T (2<sup>nd</sup> part))

RTM-MP 004e

Connectors are shown form the mating side.



### 4.10 Connectors EMGZ443MP.R (static machine part)

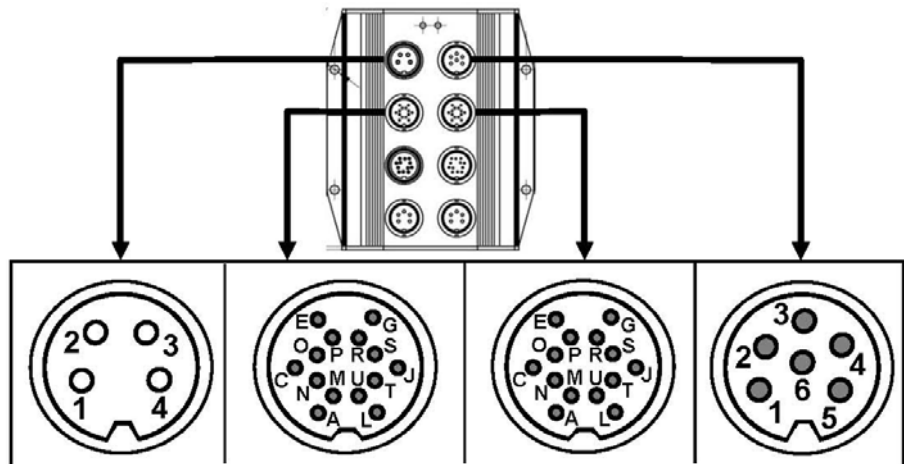

Pin	Colour	Ana Out 4-p (f)	Enco 1 14-p (f)	Enco 2 14-p (f)	Ana In 6-p (m)	
1	A	white	0...10 VDC	A+	A+	0...10 VDC
2	C	brown	AGND	B+	B+	AGND
3	E	green	4...20 mA	Ref+ (inactive)	Ref+ (inactive)	-4...20 mA
4	G	yellow	Shield	Status	Status	Shield
5	J	grey		Shield	Shield	Bridge
6	L	pink		A-	A-	Bridge
	M	blue		B-	B-	
	N			NC	NC	
	O			NC	NC	
	P			NC	NC	
	R			NC	NC	
	S	red		Ref- (inactive)	Ref- (inactive)	
	T	black		GND	GND	
	U	purple		24 V ENC	24 V ENC	

Fig. 10: Signal assignment EMGZ443MP.R (1<sup>st</sup> part))

RTM-MP005e

Connectors are shown form the mating side.

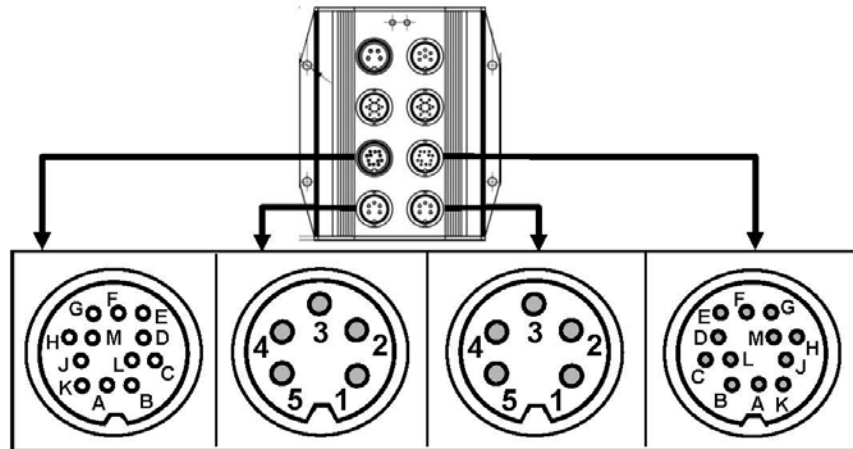

Pin	Colour	Dig. Out 12-p (f)	Power & Bus 5-p (m)	Power & Bus 5-p (m)	Dig. In 12-p (m)	
1	A	white	Dig. Out 1	24 VDC	24 VDC	Dig. In 1
2	B	brown	Dig. Out 3	PGND	PGND	Dig. In 3
3	C	green	Dig. Out 5	RS485 A	RS485 A	Dig. In 5
4	D	yellow	Dig. Out 7	RS485 B	RS485 B	Dig. In 7
5	E	grey	24 VDC	GND	GND	24 VDC
	F	pink	PGND			PGND
	G	blue	Dig. Out 2			Dig. In 2
	H	red	Dig. Out 4			Dig. In 4
	J	black	Dig. Out 6			Dig. In 6
	K	purple	Dig. Out 8			Dig. In 8
	L	gry/pin	24 VDC			24 VDC
	M	red/blu	PGND			PGND

Fig. 11: Signal assignment EMGZ443MP.R (2<sup>nd</sup> part)

RTM-MP006e

Connectors are shown form the mating side.

## 5 Configuration of the RTM MP System

FMS delivers the RTM MP System with preset hardware components, installed software, a configured 2.4 GHz radio-link.

### 5.1 RTM MP Quick Start

1. After having mounted and wired the RTM MP system components on your machine power up transmitter EMGZ482T.MP and receiver EMGZ482R.MP
2. The RTM MP system will establish the wireless radio link automatically. This initial process can take 5-10 sec.
3. After having achieved a stable radio link the LCD display on the EMGZ482R.MP will show:

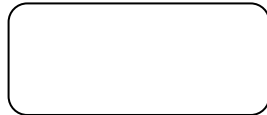

4. The system is now ready to be calibrated.

### 5.2 Description of the Operating Panel EMGZ482R.MP

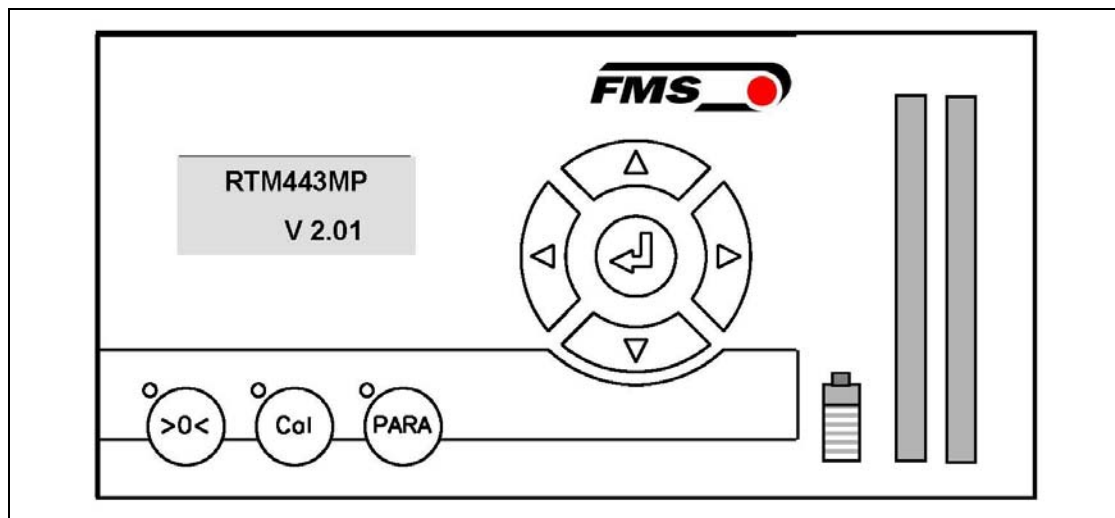









Fig. 12: View of the Operating Panel EMGZ482R.MP

RTM-MP 009

The battery symbol on the operation panel indicates the status of the supply voltage in the EMGZ482R.MP unit.

The keys on the operating panel of the EMGZ482R.MP version are all deactivated and have not their normal function as in the standard version.

Key	Key function during operation
	Key deactivated
	Key deactivated
	Key deactivated
	Key deactivated
	Keys deactivated
	Key deactivated
	Key deactivated

### 5.3 Offset Compensation Procedure

With the Offset Compensation one can compensate the roller weight of the sensor. This procedure is always performed before the calibration. The roller weight compensation is performed for both channels (sensor 1 and sensor 2). The force measuring roller should not be loaded while the Offset Compensation is being done.

Procedure:

1. Remove any wires that may apply a force to the roller.
2. Close a contact between terminal 10 and 13 on the EMGZ482R.MP (see Fig. 6). The switch time must be >100 ms.
3. This connection will perform the offset compensation on both force measuring rollers (sensor 1 and 2).

## 5.4 Calibration Methods

The Calibrating procedure (setting the Gain), adjusts the controller and force sensors so that the output gives you the actual tension value. There are two methods of calibrating the system. The first method uses a defined weight. The second method is based on a calculation method in conjunction with the FMS Calculator. This Calculator can be downloaded from the FMS web page. FMS recommends using the method with the weight (see Fig. 13) since it delivers the most accurate results.

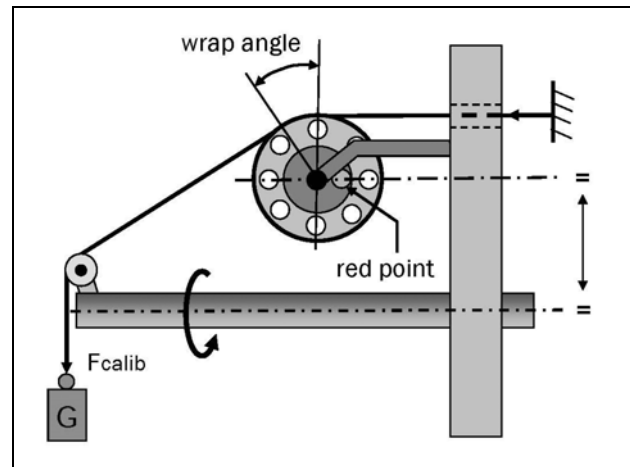

Fig. 13: Calibrating the measuring amplifier  
RTM00020e

## 5.5 Calibration Procedure

1. The calibration of the sensors must be performed with the PLC
2. Load a rope on the roller with the weight corresponding to your calibration force. The roller configuration must correspond to the real material path in the machine (wrap angle, distances between the rollers etc.).
3. The RTM MP-system will deliver tension raw data via the corresponding output
4. Enter the force data in your PLC and calibrate it matching your controlling needs.

## 5.6 Relay Output for Lost Communication

The relay output on the receiver EMGZ482R.MP becomes active, if the communication link between receiver and transmitter is lost. For the technical specification of the relay output see chapter 8 "Technical Data", Table EMGZ482R.MP.

## 6 Mechanical Dimensions

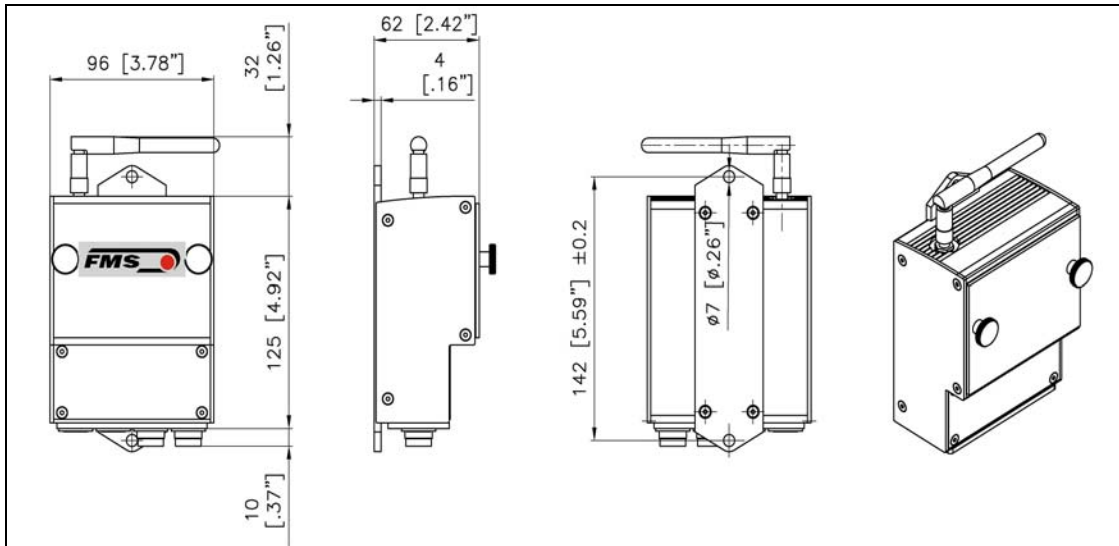

**Fig. 14: Dimensions EMGZ482T.MP.24VDC**

RTMX2 0020US

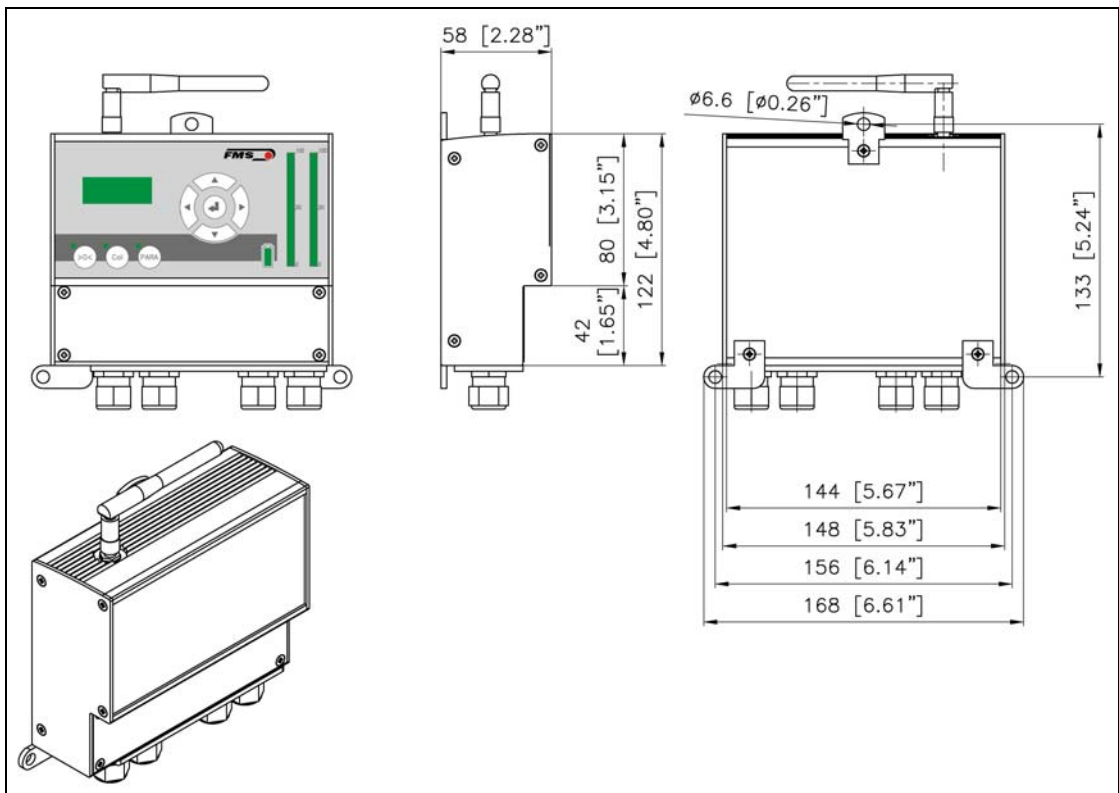

**Fig. 15: Dimensions EMGZ482R.MP**

RTX2 0018US

The EMGZ443MP.T and EMGZ443MP.T differ in their connector assignment. The mechanical dimensions of the housing are the same.

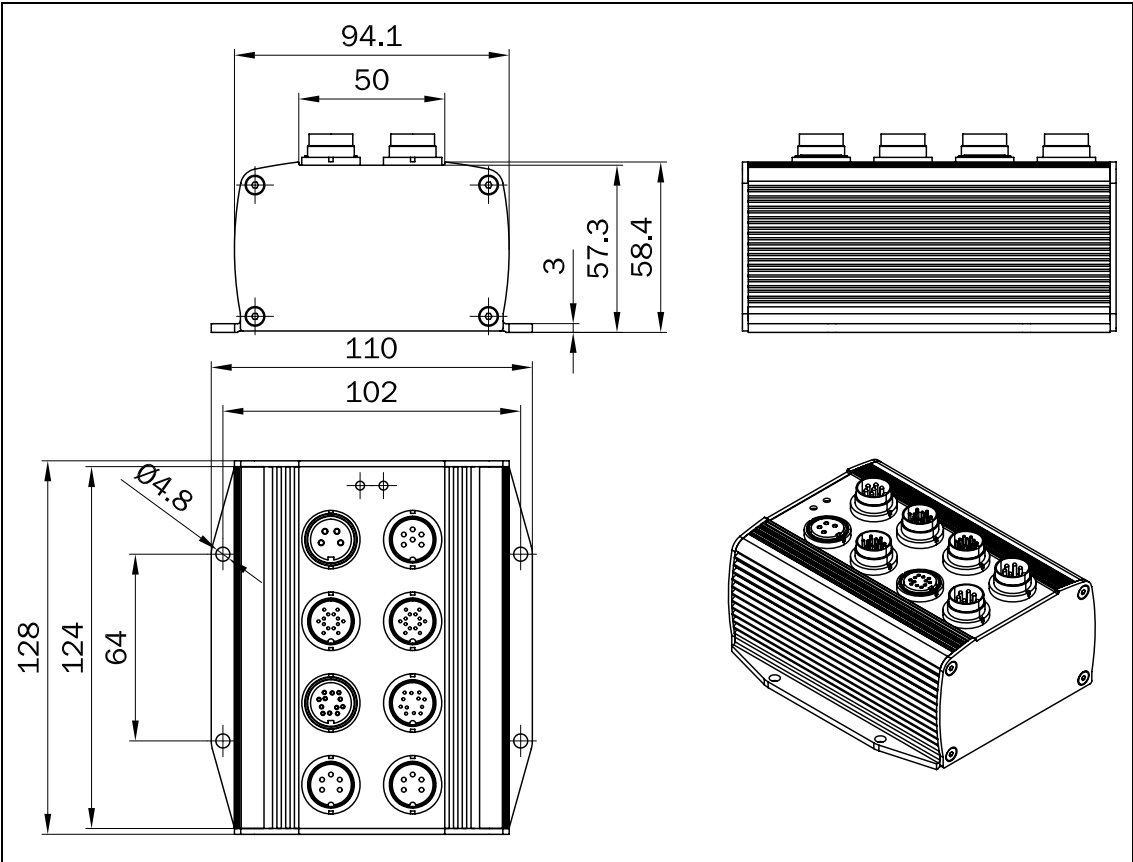

Fig. 16: Outline Drawing EMGZ443MP.T and EMGZ443MP.R

E443001

## 7 Trouble Shooting

Error	Cause	Corrective action
<b>Relay "Radio lost" is active</b>	Radio link to EMGZ482R.MP is interrupted.  Metallic objects between transmitter and receiver cause radio interferences	Speisespannung an EMGZ482T.MP.24VDC und EMGZ443MP.T überprüfen  Remove metallic objects from the radio path.
<b>Feedback value doesn't correspond to the effective material tension</b>	Sheave weight influences the measurement	Perform Offset compensation (see <b>chapter 5.3</b> )
<b>Periodic oscillation on wire tension reading</b>	Sheave weight influences the measurement  or  Alignment of red point is incorrect	Perform Offset compensation (see <b>chapter 5.3</b> ) or  See <b>chapter 4.2 and 4.3</b> . Align red point correspondingly and re-calibrate the system ( <b>chapters 5.4 and 5.5</b> ).
<b>Feedback value doesn't correspond to the effective material tension</b>	Alignment of red point is incorrect	See <b>chapter 4.2 and 4.3</b> . Align red point correspondingly and re-calibrate the system ( <b>chapters 5.4 and 5.5</b> ).
<b>Very low tension values on PLC not corresponding to the effective material tension</b>	Gain badly calculated  or  Wrongly calibrated	Re-calibrate the system ( <b>chapters 5.4 and 5.5</b> ) and write correct gain factor in PLC



## 8 Technical Data

<b>EMGZ482T.MP.24VDC</b>	
<b>Number of Channel</b>	2 channels for 2 sensors
<b>Measuring Error</b>	<0.05% FS
<b>Sensor Supply</b>	3.0 VDC, max. 20mA, high stability
<b>Power Supply</b>	24VDC via slip rings (18...36VDC /10W max. 0.5A)
<b>Resolution A/D Converter</b>	±8192 Digit (14 Bit)
<b>Wireless Interface</b>	2.44 GHz
<b>Analogue Input 1</b>	1 sensor with strain gauges @ 350 Ω (0...5.4 mV, max. 7.4 mV)
<b>Analogue Input 2</b>	1 sensor with strain gauges @ 350 Ω (0...5.4 mV, max. 7.4 mV)
<b>Temperature Range</b>	0...50 °C [32...122 °F]
<b>Protection Class</b>	IP52
<b>Weight</b>	0.52 kg [1.15 lbs]

<b>EMGZ482R.MP</b>	
<b>Number of Channel</b>	2 channels
<b>Displays</b>	LCD 2x 8 characters (8mm) Supply voltage indicator
<b>Propagation delay</b>	≤ 5ms
<b>Resolution D/A Converter</b>	0...4096 (12 Bit)
<b>Wireless Interface</b>	2.44 GHz
<b>Analogue Output 1</b>	0...10 VDC; min. 1.2kΩ or 4...20mA, max. 500Ω
<b>Analogue Output 2</b>	0...10 VDC; min. 1.2kΩ or 4...20mA, max. 500Ω
<b>Relay Output</b>	1 output (DC: 24V/0.5A/12W; AC:24V/0.5A/12VA)
<b>Power Supply</b>	24VDC (18...36VDC) / 10W (max. 0.5A)
<b>Temperature Range</b>	0...50 °C [32...122 °F]
<b>Protection Class</b>	IP52
<b>Weight</b>	0.65 kg [1.43 lbs]

<b>EMGZ443MP.T</b>	
<b>Propagation delay</b>	≤ 5 ms
<b>Interface</b>	RS485 Proprietary
<b>Analogue output</b>	0...10 VDC or 4...20mA
<b>Analogue input</b>	0...10 VDC or 4...20mA
<b>Encoder inputs</b>	2 channels max. 100kHz
<b>Digital outputs</b>	8 outputs; max. 100 mA / output (source)
<b>Digital inputs</b>	8 inputs 5...36 VDC
<b>Power supply</b>	24VDC (18...36VDC) max. 0.4A
<b>Encoder power supply</b>	HTL (15...30 VDC; max. 2 W)
<b>Power consumption</b>	max. 10W
<b>Temperature range</b>	0...+50 °C [32...122 °F]
<b>Protection class</b>	IP52
<b>Weight</b>	0.6 kg [1.32 lbs]

<b>EMGZ443MP.R</b>	
<b>Propagation delay</b>	≤ 5 ms
<b>Interface</b>	RS485 Proprietary
<b>Analogue output</b>	0...10 VDC or 4...20mA
<b>Analogue input</b>	0...10 VDC or 4...20mA
<b>Encoder inputs</b>	2 channels max. 100kHz
<b>Digital outputs</b>	8 outputs; max. 100 mA / output (source)
<b>Digital inputs</b>	8 inputs 5...36 VDC
<b>Power supply</b>	24VDC (18...36VDC) max. 0.6A
<b>Encoder power supply</b>	HTL (15...30 VDC; max. 2 W)
<b>Power consumption</b>	max. 15W
<b>Temperature range</b>	0...+50 °C [32...122 °F]
<b>Protection class</b>	IP52
<b>Weight</b>	0.6 kg [1.32 lbs]





**FMS Force Measuring Systems AG**  
Aspstrasse 6  
8154 Oberglatt (Switzerland)  
Tel. +41 44 852 80 80  
Fax +41 44 850 60 06  
info@fms-technology.com  
www.fms-technology.com

**FMS Italy**  
Via Baranzate 67  
I-20026 Novate Milanese  
Tel: +39 02 39487035  
Fax: +39 02 39487035  
fmsit@fms-  
technology.com

**FMS USA, Inc.**  
2155 Stonington Ave. Suite 119  
Hoffman Estates, IL 60169 USA  
Tel. +1 847 519 4400  
Fax +1 847 519 4401  
fmsusa@fms-technology.com

**FMS UK**  
Highfield, Atch Lench Road  
Church Lench  
Evesham WR11 4UG, Great Britain  
Tel. +44 1386 871023  
Fax +44 1386 871021  
fmsuk@fms-technology.com