

ELMON rail 41-322 ELMON rail 41-822



Betriebsanleitung (Original, Gültigkeit siehe letzte Seite)
ELMON rail 41-322 / ELMON rail 41-822 Sicherheitsschaltgerät Seite 3-13

Deutsch

Operating Manual (see last page for validity)
ELMON rail 41-322 / ELMON rail 41-822 Safety Relais Page 14-24

English

Manuel d'utilisation (Validité voir la dernière page)
ELMON rail 41-322 / ELMON rail 41-822 Relais de sécurité Page 25-35

Français

1. Table of Contents

1. Table of Contents	14
2. General safety regulations and protection measures	15
3. General and function description	16
4. Intended use	17
5. Application example	17
6. Device overview	18
6.1 Versions	18
6.2 Signal indicators	18
6.3 Connection terminals	18
6.4 DIP switch for configuring the operating mode	19
7. Operating modes	19
7.1 Safety output	19
7.2 Automatic reset	19
7.3 Fault self-retaining – manual reset	19
7.4 Signaling output without any delay (RLU)	19
7.5 Signaling output delayed (RL)	19
8. Mechanical mounting	20
9. Electrical connection	20
9.1 Supply voltage	20
9.2 Connection of sensor	20
9.3 Connection of multiple sensors per sensor circuit.	20
9.4 Connection of control circuits.	21
9.5 Connection Reset.	21
9.6 Connection of signaling contact.	21
10. Commissioning and function testing.	22
11. Fault diagnosis	22
12. Decommissioning and disposal.	22
13. Technical data	23
14. EC Declaration of Conformity.	24

All rights reserved to implement technical and operationally relevant changes of the products and devices shown in this documentation at any time without prior notice.

2. General safety regulations and protection measures

- The manufacturer and user of the system/machine on which the protection system is used are responsible for coordinating and adhering to all applicable safety rules and regulations under their own responsibility.
- The protection system guarantees functional safety in combination with the superordinate control system, but not the safety of the entire system/machine. Thus, a safety review of the entire system/machine in accordance with machine directive 2006/42/EC or relevant product standards is necessary prior to use of the device.
- The operating instructions must be permanently available at the operating location of the protection device. They must be thoroughly read and applied by every person who is tasked with the operation, maintenance or repair of the protection device.
- The installation and start-up of the protection device may only be conducted by specialized personnel who are familiar with these operating instructions and the applicable regulations on job safety and accident prevention. The instructions in these operating instructions must be followed and adhered to unconditionally.
- Electrical work may only be carried out by skilled electricians. Safety regulations for electrical engineering and from the professional association must be followed.
- In case work has to be carried out on the switching device, it must be switched to a voltage-free position and checked for freedom from any voltage and secured against being switched back on again.
- If the potential-free connections of the safety switching contacts are supplied with a hazardous voltage from an external source, it must be ensured that these are also switched off when working on the switching device.
- The switching device does not contain any components that the user must service. Any warranty or liability on the part of the manufacturer is forfeited in the event of any unauthorized modifications or repairs to the switching device.
- Auxiliary outputs must not execute any safety-orientated functions. They are not fail-safe and are not checked either by testing.



The system must be checked for correct function in suitable intervals by qualified persons for the standard-conform design of the safety system. The check must be documented in a way that allows it to be traced at any time.

English

In the case of non-compliance or deliberate abuse, the manufacturer's liability will cease.

3. General and function description

The ELMON rail 41-322 (ELMON rail 41-822) switching device is used to evaluate sensors such as safety contact mats, safety contact edges and safety bumpers for securing crush and shear locations.

An ASO sensor can be connected to the switching device. The steady-state current monitoring of the sensor is made possible by an integrated terminating resistor in the sensor.

Furthermore, the device can also evaluate a sensor in four-wire technology.

If the desired steady-state current flows, the safety relays are driven and the switching contacts closed. If the sensor is operated or the sensor circuit is interrupted, the relay switching contacts open.

A signal output with potential-free switching contacts is available. An operation of the sensor causes a reaction of the signal output in accordance with the DIP switch configuration. The signal output must not execute any safety-orientated functions. It is not fail-safe and not checked by testing either.

The switching device has been designed and type-approved in accordance with EN ISO 13849-1 "Safety-related parts of control systems" for category 3 Performance Level e. For compliance with category 3, the safety output is set up redundantly with two independent switching elements.

In addition the device has been type-approved according to EN 62061 "Functional safety of safety-related electrical, electronic and programmable electronic control systems" and can meet a safety function up to SIL 3.

The monitoring state of the sensor and the applied operating voltage are indicated by LED.

If there is a fault alarm, all safety outputs are inactive.



The unit can be used in a household environment as well as an industrial environment up to an altitude of 2000m above mean sea level. The unit must not be operated in areas with major temperature changes.

English

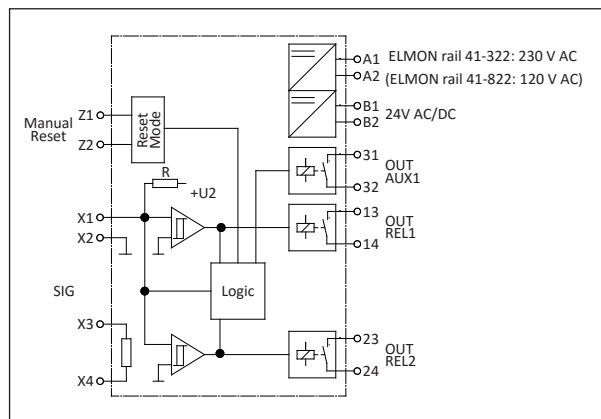

Functional circuit diagram

4. Intended use

The switching device can only fulfill its safety-relevant task, if it is used as intended within specifications. The intended use of the switching device is the use as a protection system in connection with safety contact mats, safety bumpers and safety contact edges with 8.2 kΩ resistance for steady-state current monitoring. It is not allowed to use the safety relay in heights over 2000 m above sea level or potentially explosive atmospheres.

A different use or any use going beyond the intended use is not within specifications. The manufacturer does not accept any liability for any damage arising from use not within specifications. Any use for special applications requires prior release by the manufacturer.

5. Application example

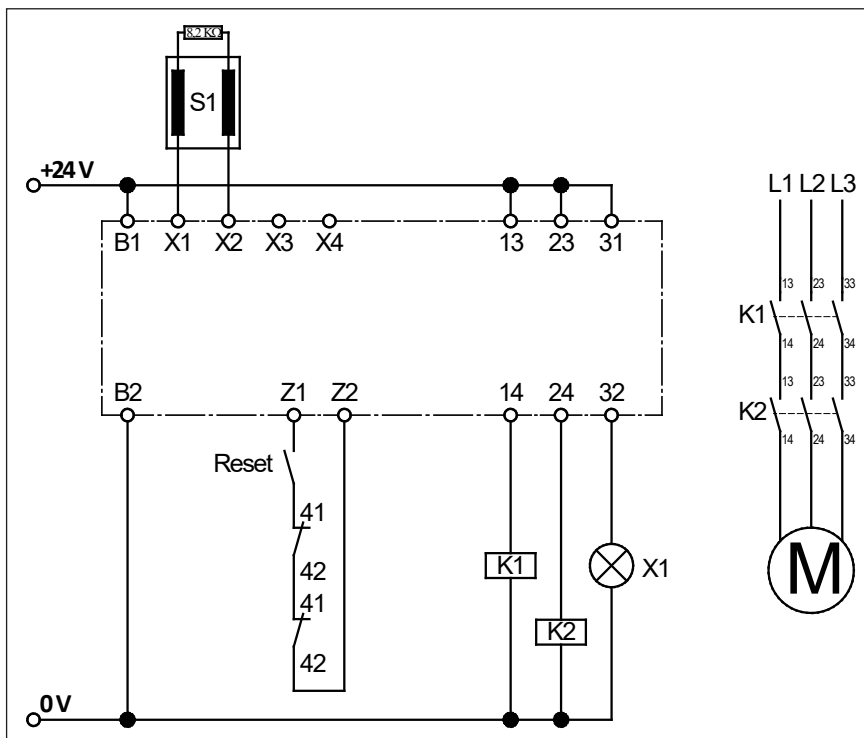

Safety-orientated monitoring of a safety contact strip with start release via release pushbutton and separate continuation of the control circuits (category 3 compliant application according to EN ISO 13849-1).

In order to check the functionality of the load breaking K1 and K2 relays the break contacts of these contactors are integrated into the start circuit (Z1 Z2).

The signaling relay output is used to visualize the switching state of the safety contact strip.

Circuit diagram in voltage-free state. Sensor not operated.

1 Sensor (edge, mat or bumper)

2 Release key

English

6. Device overview

6.1 Versions

Version	Supply voltage
ELMON rail 41-322	230 V 50/60Hz and 24 V AC/DC
ELMON rail 41-822	120 V 50/60 Hz and 24V AC/DC

6.2 Signal indicators

<p>LED Power (green) Operating state (on) Fault alarm (pulse)</p>
<p>LED CH 1 (red) Sensor operated (on) Sensor power circuit interrupted (fast flashing) Fault self-retaining (slow flashing)</p>
<p>LED AUX 1 (yellow) Signal output switched</p>

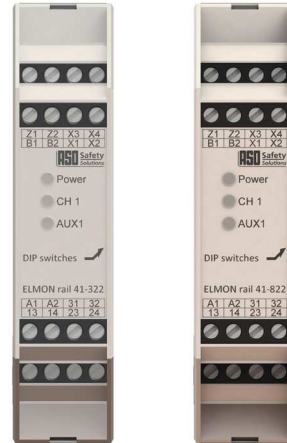

ELMON rail 41-322 ELMON rail 41-822

If there is no fault alarm, then the operating state is shown via the **Power** LED (on). When a fault alarm is issued, the number of pulses output indicates the fault:

Pulse	Fault alarm
1	Voltage supply outside the valid value range
2	Fault when testing signal input
3	Output control relay faulty
4	Data transmission between micro-controllers faulty

English

6.3 Connection terminals

A1 A2	ELMON rail 41-322: Supply voltage 230 V 50/60 Hz ELMON rail 41-822: Supply voltage 120 V 50/60 Hz
B1 B2	Supply voltage 24 V AC/DC
X1 X2	Connection sensor
X3 X4	Internal terminating resistor
13 14	Switching contact safety relay 1
23 24	Switching contact safety relay 2
31 32	Switching contact signal relay
Z1 Z2	Connection manual reset /re-start (key NO; optional)

6.4 DIP switch for configuring the operating mode

S1

„ON“: Automatic reset
 „OFF“: Fault self-retaining – manual reset (factory setting)

S2

„ON“: AUX1 Mode signal output: RLU
 „OFF“: AUX1 Mode signal output: RL (factory setting)

7. Operating modes

7.1 Safety output

Separate or series-connected output of the control circuits (redundant continuation of the switching contacts). In order to use the two safety relays separately, the bridge between **14** and **23** must be removed.

7.2 Automatic reset

(S1 = „ON“)

After removing a fault in a sensor circuit or after a voltage failure, the switching unit will automatically release output again.

7.3 Fault self-retaining – manual reset

(S1 = „OFF“)

Following removal a fault of in a sensor circuit, or after a voltage failure, the switching unit will only release the output(s) again, if the **Z1** and **Z2** contacts, 500 ms after the elimination of the disruption, are closed by means of a pushbutton. This completely prevents any automatic re-start. A permanent bridging of the **Z1** and **Z2** contacts does not cause an automatic reset.

7.4 Signaling output without any delay (RLU)

(S2 = „ON“)

In this mode of operation the corresponding signaling output is activated without delay, if any fault is signaled on the corresponding channel. The output is always inactive in the de-energized state of the switching device.

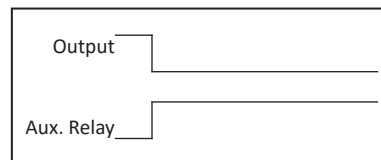

Safety output (symbolic)
 Signaling output (symbolic)

7.5 Signaling output delayed (RL)

(S2 = „OFF“)

In this operating mode the corresponding signaling output is activated with a delay of 0.5 seconds and then remains active for a maximum of 3 seconds, if a fault is signaled.

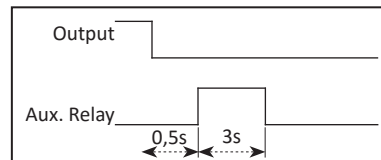

Safety output (symbolic)
 Signaling output (symbolic)

English

8. Mechanical mounting

The switching unit must be mounted correctly:



- In a dust-protected and moisture-protected switch cabinet or casing.
- For use in an environment with level 2 contamination.
- With a protection type of at least IP54.
- On a 35 mm DIN support rail according to EN 50 022.

The switching unit can be installed in any position.

The unit must not be operated in areas with major temperature changes.

9. Electrical connection



The switching unit can be destroyed by connection to the incorrect terminals.

Lines that are routed in the open air or outside the switch cabinet must be protected accordingly.

The limit values stated in the "Technical Data" for the supply voltage and the switching capability of the relay must be observed.

9.1 Supply voltage



The supply voltage can **optionally** be effected by means of a mains voltage of 230 V AC 50/60Hz (ELMON rail 41-822: 120 V AC 50/60 Hz) or a low voltage of 24 V AC/DC. For a supply with 24 V AC/DC the voltage must correspond to the requirements for protective low voltages (SELV). The supply line to the switching device must be protected by means of a 5x20 glass tube fuse 200mA medium time lag.

Never apply both voltages simultaneously!

The 230 V (120 V) supply voltage must be applied to the **A1** and **A2** terminals. For operation with 24 V, the supply voltage must be applied to the **B1** and **B2** terminals.

For a fixed installation a separating device must be available (for example, a main switch for the system). A mains plug is sufficient as a separating device, if it is freely accessible.

English

9.2 Connection of sensor

The sensor with a terminating resistor of 8.2 k Ω must be connected to the **X1** and **X2** terminals.

The sensor without a terminating resistor is connected to the **X1** and **X2** terminals by means of one lead and with the other lead to the **X3** and **X4** terminals.

9.3 Connection of several sensors per sensor circuit



ASO-Sensors must not be connected in parallel.

One or several sensors can be connected to the signal transmitter input. For this purpose, the individual sensors are connected in series in accordance with Figure 1.

Safety contact edge SENTIR edge:

A maximum of 5 SENTIR edge devices can be connected in series. The maximum total length of the SENTIR edge must not exceed 100 m.

The length of a SENTIR edge can be up to 25 m.

The total line length of the series-connected SENTIR edge must not exceed 25 m.

Safety contact bumper SENTIR bumper:

A maximum of 5 SENTIR bumper devices can be connected in series. The maximum total length of the SENTIR bumpers must not exceed 15 m.

The length of a SENTIR bumper may be up to 3 m.

The total line length of the series-connected SENTIR bumpers must not exceed 25 m.

Safety contact mat SENTIR mat:

A maximum of 10 SENTIR mats can be connected in series. The maximum total surface area must not exceed 10 m².

The size of a SENTIR mat can be up to 1350 x 2350 mm.

The total line length of the series-connected SENTIR mat must not exceed 25 m.

Before connecting the series-connected sensors, it is recommended to measure the resistance value of the wiring. In the case of non-operated sensors the resistance must be 8.2 kΩ ± 500 Ω. If the sensor is operated, the resistance must not exceed 500 Ω.

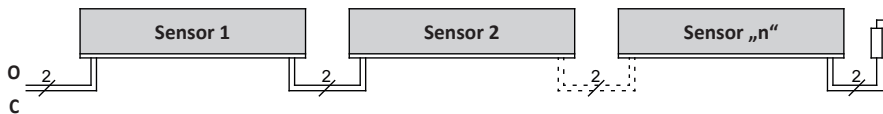

Fig. 1: Interconnecting several sensors, here using the example of the safety contact edge

9.4 Connection of control circuits

Connect the control circuit to be monitored to the **13** and **24** terminals. If the switching contacts are redundantly continued, the factory-inserted bridge between the **14** and **23** terminals must be removed.



In the event of any redundant use of the switching contacts only voltages with the same potential may be connected. The use of different voltage potentials does not correspond to any intended use within specifications.

Depending on the nominal current, the control circuits are to be protected by a corresponding fuse, or the nominal current on the control circuits must be limited to the maximum value by means of other measures.

9.5 Connection Reset

For the operating mode "manual reset" the necessary reset switch must be connected to the **Z1** and **Z2** terminals.

9.6 Connection of signaling contact

The 31 and 32 signaling contact only serves as an auxiliary contact (signaling, display etc.) and must not be integrated into the safety circuit.



The signaling contact may only switch extra low voltages (24V). The switching of low voltages (230V) is not permissible.

10. Commissioning and function testing

Following a corresponding connection of all electrical connections and switching on the supply voltage, the system / machine must be checked for correct functionality.

After successful commissioning the **13** and **24** safety output is driven (relay contact "closed"). An operation of the sensor causes an opening of the **13** and **24** relay contact.

The signaling relay (**31 32** connection) switches in accordance with the present DIP switch position. This is indicated by means of the yellow **AUX1** LED.

The safety system must be inspected by competent specialists at suitable intervals. The check must be documented in a way that allows it to be traced at any time. The requirements of the system / machine manufacturer are to be taken into account and observed.

11. Fault diagnosis

If the supply voltage is correctly wired and applied, only the green **Power** LED may be lit up. If the red LED illuminates, there is a fault in the system which can be delimited by means of the LED.

LED	Fault	Fault removal
green Power LED does not light up	Supply voltage is missing, too low or incorrectly connected.	Check connections and supply voltage: - 230 V AC (or 120 V) at terminals A1 A2 or - 24 V AC/DC at terminals B1 B2 Tolerance range: $\pm 10\%$
green Power LED flashes cyclically (pulse output)	Internal fault is indicated by the number of pulses.	See -> signal displays
red CH1 LED lights up	The corresponding sensor is recognized as being operated.	- Check the connections of the corresponding sensors (squeezed or brittle supply lines, etc.) - Check signal sensor *
red CH1 LED fast flashing	Sensor circuit interrupted, sensor not connected, defectively connected or defective.	- Check the connections of the corresponding sensors (squeezed or brittle supply lines, etc.) - Check signal sensor *
red CH1 LED slow flashing	Fault self-retaining	Carry out manual reset

English

* If the fault is not found in the wiring, the function of the electronic system can be checked by applying a resistance of 8.2 k Ω to the sensor-input on the switching device. Subsequently, if the electronics work perfectly, the sensor must be checked by means of an ohmmeter. For this purpose, the connection of the sensor to the switching device must be separated and connected by means of an ohmmeter. In the case of a non-operated sensor the resistance must be 8.2 k Ω \pm 500 Ω . If the sensor is operated, the resistance must not exceed 500 Ω .

12. Decommissioning and disposal

The products manufactured by ASO are exclusively intended for commercial use (B2B). At the end of use, the products must be disposed of according to all local, regional and national regulations. ASO is also happy to take back the products and disposes of them properly.

ELMON rail 41-322 / ELMON rail 41-822 Safety Relais



13. Technical data

Supply voltage

Mains voltage	U _{Netz}	ELMON rail 41-322: 230 V AC ± 10% 50/60 Hz ELMON rail 41-822: 120 V AC ± 10% 50/60 Hz
Low voltage	U _E	24 V AC/DC ±10%
Power consumption	P _{Netz_max}	3,5 VA 230 V AC 3,8 VA 120V AC 50Hz / 3,5VA 120V AC 60Hz
	P _{E_max}	1,5 W 24 V DC
	P _{E_max}	1,2 VA 24 V AC
Fuse Mains voltage (external)		200 mA middle time-lag fuse (glass tube 5x20)
Fuse Low voltage (external)		200 mA middle time-lag fuse (glass tube 5x20)

Terminating resistor – sensor

Nominal value	R _{Nom}	= 8,2 kΩ
upper switching value	R _{AO}	> 12,0 kΩ
lower switching value	R _{AU}	< 5,0 kΩ

Safety relay

Nominal current DC	1 A (24 V DC)
Nominal current AC	1 A (230 V AC)
Mechanical service life	>10 ⁶ operations
Switch-off delay (reaction time)	< 11 ms
Switch-on delay	≤ 550 ms (Power on < 850 ms)
Utilization category	AC-15 (230V AC; 1A; 800000 Op.) DC-13 (24V DC; 1A; 950000 Op.)
Protection	1A middle time-lag fuse (glass tube 5x20)

Signal relay

Max. switching current	2 A (24 V AC/DC)
Mechanical service life	> 10 ⁶ operations
Operating mode RL: Switch-on delay	0,5 Sek.
Operating mode RL: Switch-on duration	3 sec.

With the RLU version, the signal relay switches synchronously to the operation of the signal transmitter.

Housing	Polyamide PA 6.6 Self-extinguishing according to UL 94-V2
Dimensions (HxWxD)	99 x 22,5 x 114 mm
Protection type	IP20
Protection	class II (protective insulation) 
Pollution Degree	2
Overtoltage category	III
Rated insulation voltage	250 V
Rated impulse voltage resistance	4,00 kV
Weight	210 g
Temperature range single mounting	-20 °C to +55 °C
Temperature range mounting in row	max. +35 °C
Connection cable cross-section	single- or fine-stranded cable 0,75-1,5 mm ²
Temperature class copper conductors	60/75°C

Certifications

ELMON rail 41-322 (41-822)	EN ISO 13849-1:2015 Category 3 PL e (MTTFD 195 years, DC 99 %) EN 62061:2013 SILCL 3 (PFHd 6,51E-09 1/h)
Electronics	MTTFD 625 years, DC 99 %
Electromechanics	B10D 500000 MTTFD 285 years, DC 99% (Nop 17520)

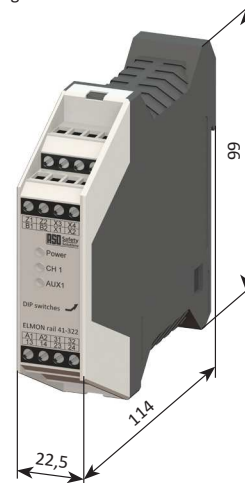

English



13. EC declaration of conformity

We hereby declare that the following products of the series:

ELMON rail 41-322

(article number 1114-0030, format serial number yymmnnnnn)

ELMON rail 41-822

(article number 1114-0040, format serial number yymmnnnnn)

Safety switching device for the combination of switching edges, switching mats and switching bumpers for avoiding hazards at crush and shear locations corresponds to the relevant basic safety and health requirements of the following EC Directives as a result of its conception and construction as well as the design we put on the market:

Machine Directive 2006/42/EC

EN ISO 13849-1:2015
EN ISO 13849-2:2013-2
EN 62061:2013-09
EN 60947-5-1:2010-04
EN 61000-6-2:2005
EN 61000-6-3:2007

EC - type approval

Notified Body 0044
TÜV NORD CERT GmbH
Langemarckstraße 20
D-45141 Essen
EC type-examination no.: 44 205 13031827

English

This declaration of conformity does not absolve the machine designer/manufacturer of his obligation to guarantee the conformity of the overall machine to which this product is attached in accordance with the EC Directive.

Manufacturer and authorized representative for documents:

ASO, Antriebs- und Steuerungstechnik GmbH,
Hansastraße 52, D 59557 Lippstadt

