

Automatic filter AF 119 S

with internal pressure cleaning and integrated cyclone effect
Nominal diameter: DN 100, 125, 150, 200

1. Features

Filtration Group automatic backflush filters are suitable for all applications where low or medium-viscosity liquids have to be filtered.

These compact, inline filter systems are designed for automatic cleaning. The system is cleaned by rotating the filter cartridge and backflushing with cleaned internal pressure media.

Advantages:

- Low lifecycle costs because no filter material is consumed
- Cleaning without interrupting filtration
- Precise separation quality in accordance with the surface filter principle
- Top-quality, asymmetric filter medium made of multiple-sintered stainless steel fleece on a robust inner core
- Efficient filter cleaning assures maximum process stability
- Solid construction and high-quality materials for a long service life
- Minimal liquid loss during cleaning
- Filter cleaned one segment at a time with a high backflush pulse
- Actual filter rating and nominal separation are indicated
- Integrated preseparation thanks to tangential inflow and preseparator tube
- Material options open up a wide range of applications (also for high abrasive media)
- Modular Filtration Group Vario system for optimum filter selection
- Optional: Gas-tight shaft seals available
- Optional: Application in Ex zone 1 and 2
- Optional Certification for Pressure Equipment Directive (PED)
- Optional: Acceptance for AMSE U-Stamp
- Easy maintenance
- Worldwide distribution



2. Operating principle

The Filtration Group AF 119 S backflush filter belongs to the large Vario series. The compact Filtration Group automatic filter system is used for fine and micro-filtration of a variety of low-viscosity liquids.

This inline pressure filter consumes no filter material, which means there is also no need for subsequent disposal. The filter is cleaned without interrupting operation. The concentrated solids are drained off simply by opening the system for a short time.

The medium to be cleaned is guided into the filter housing under pressure. It flows inward through the Filtration Group segmented element. Particles settle on the surface of the filter medium. The filtered fluid exits the filter housing at the top opposite the inlet connection.

The integrated preseparator relieves the load on the segmented element, particularly from coarse and heavy particles. This permits a tangential flow around the preseparator tube and the deflection edges.

The filter is cleaned when a preset differential pressure limit, a set interval or a defined filtered fluid quantity is reached.

The segmented element is turned as the cleaning and external pressure valves are opened. The segments are then guided one at a time past the outside backflush channel. This causes them to open and close alternately. The internal pressure is built up at a throttle point downstream of the filter, so that when one segment opens, an outward surge cleans the separated particles from the filter material. As a result of this pulse cleaning principle, the particles are catapulted out, collected in the backflush channel and discharged with a small amount of internal medium. One turn suffices to clean all segments.

The residue that has settled in the collection cone can be emptied via the drain valve either when the machine is at a standstill or during filtration.

All filters in the Filtration Group Vario series are protected by various patents.

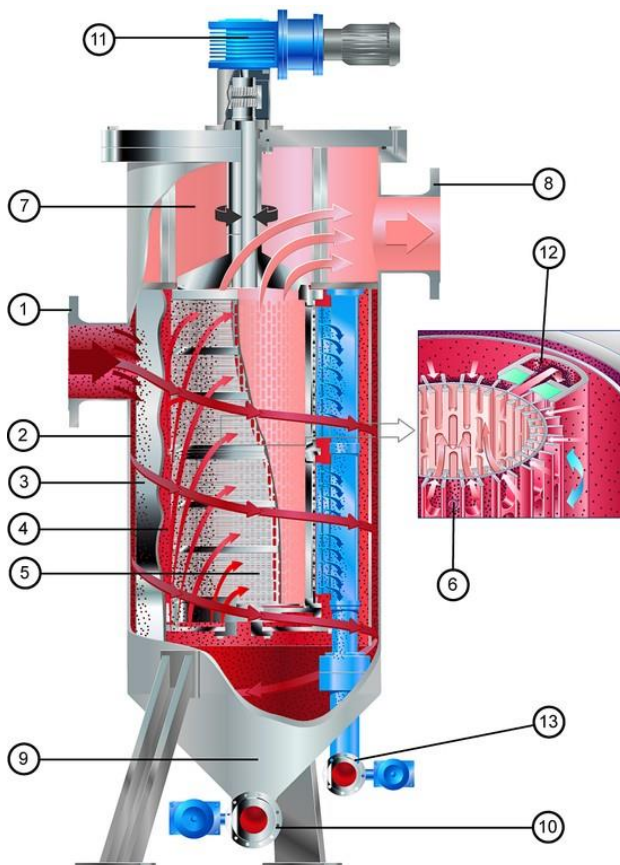

Used Filtration Group filter cartridges in the AF 119 S backflush filter:

Filtration Group topmesh cartridges (standard)

- Good cleanability due to asymmetric design
- Large effective filter surface
- Defined particle retention
- Several material combinations possible

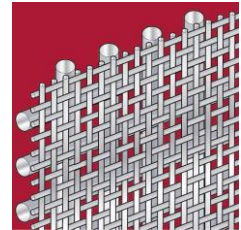

- 1 Inlet connection
- 2 Outer inlet plenum
- 3 Preseparator tube
- 4 Inner inlet plenum
- 5 Filtration Group segmented element
- 6 Filtration Group filter materials
- 7 Plenum for filtered fluid
- 8 Drain connection for filtered fluid
- 9 Residue collection cone
- 10 Drain valve
- 11 Drive motor
- 12 Flushing channel
- 13 Cleaning valve

3. Technical data

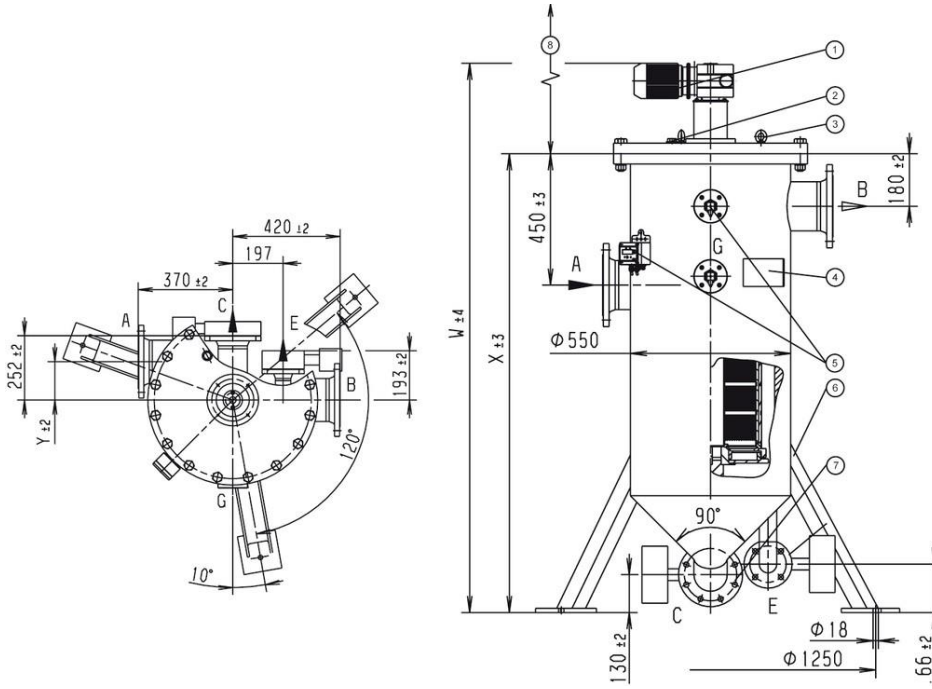

- 1 Cleaning drive: can be mounted turned 90°, 180° or 270°
- 2 Vent screw G1/4
- 3 Lifting eyebolts
- 4 Name-plate
- 5 Optional: Differential pressure indicator/switch
- 6 Feet (3 x 120°)
- 7 Optional: Drain valve, manual or automatic mode
- 8 Optional: Automatic backflush valve
- 9 Clearance required = 600 mm

Filter data

- Max. operating pressure: 10 bar
 Max. operating temperature: 100 °C
- Materials:
- Housing and cover: St. 1.4571
 - Internals: St. 1.4571
 - Bearing bushes: PTFE based
 - Seals: FPM (Viton)
 - Segmented element: 1.4571/Al (Δp max. 6 bar)
- Cover fastening:
- 16x M24 hexagon screws
 - 16x M24 hexagon nuts
- Connections and nominal diameters:
- A-inlet, B-outlet: DN 100, DN 125, DN 150, DN 200
 - C-drain: DN 50
 - D-gauge DN 25
 - E-cleaning: DN 50
 - All threaded holes acc. to DIN 3852 X
 - flanges acc. to EN 1092-1/11B1/PN 40
- Drive shaft seal: Lip seal with O-ring
 Outside coating: Synthetic resin primer, blue acc. to RAL 5007

Other types available on request!

Technical data is subject to change without notice

Motor data

Worm gear motor
 Multi-range winding

V	Hz	kW	rpm	A
Δ 230 \pm 10%	50	0.18	4.09	1.3
λ 400 \pm 10%	50	0.18	4.09	1.3
Δ 255 \pm 10%	60	0.21	4.09	1.3
λ 440 \pm 10%	60	0.21	4.09	1.3

Protection class: IP55; insulation class F; output torque: 252 Nm

Typ	W [mm]	X [mm]	Z [mm]	Volume [l]	Weight [kg]
AF 119123-.1.	1543	1232	860	239	460
AF 119133-.1.	1883	1572	1200	319	500
AF 119153-.1.	2223	1912	1540	399	540
AF 119163-.1.	2563	2252	1880	479	580

Nominal diameter	Dimension Y [mm]
DN 200	165
DN 150	190
DN 125	205
DN 100	215

Optional:

- Ex protection acc. to ATEX 2014/34/EU
- Electrical components in Ex II 2G T3
- Mechanical design in Ex II 2G c T3

Differential pressure stability:

Segmented elements (aluminium and stainless steel versions): 6 bar

4. Design and application

Cartridge type (see section 6)	Total surface in cm ²	Gap width in μm / effective filter surface in cm ²						
		10	20	30	40	60	80	100
AF 1002013	2615	2129	2129	2129	2129	2129	2129	2129
AF 1002113								

■ Recommended design

The table shows the filter surfaces for one filter cartridge.

For AF 11913.. Filter surface x 2
 AF 11915.. Filter surface x 3
 AF 11916.. Filter surface x 4

Cleaning and emptying

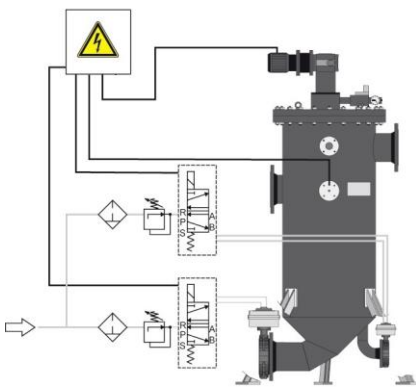

Fully automatic operation:

Filtration usually takes place under pressure. The filter is cleaned after a programmed time or a preset number of cycles or according to the differential pressure. We recommend cleaning the system at a differential pressure of approximately 0.5 to 0.7 bar. The cleaning motor is operated for around 14 s (about one turn of the filter cartridge). The cleaning valve remains open for this period. An internal pressure of 2 to 3 bar suffices to clean the filter thoroughly. The drain valve is opened in order to empty the filter. Depending on the residue concentration, this can either take place directly after cleaning or be time or cycle controlled. The opening time of the drain valve is 2 to 3 s.

Refer to the Instruction Manual for further information.

Filtration Group's team of specialists will be pleased to assist in any way. Tests can be carried out in the absence of reliable evaluation criteria.

5. Efficiency curves

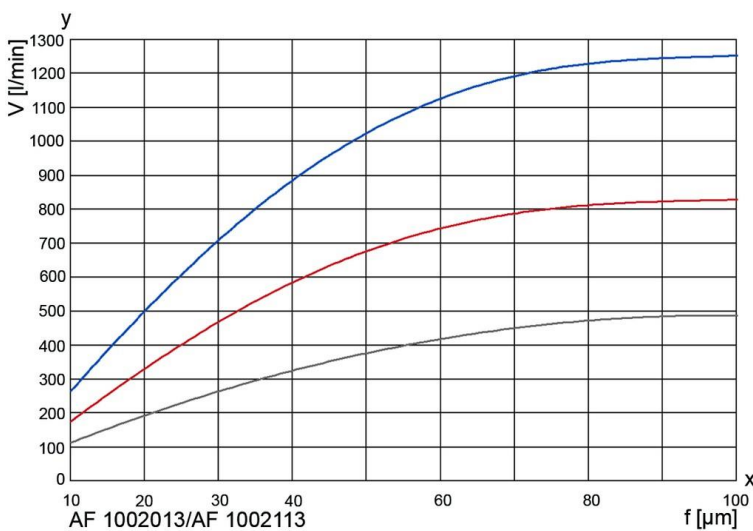

The curves indicate the volume flow through the complete filter system (filter housing including cartridge) and are referred to a differential pressure of 0.3 bar. Specific process information is essential to guarantee reliable operation of an automatic filter.

Viscosity in mm²/s
 ■ 1 mm²/s
 ■ 33 mm²/s
 ■ 100 mm²/s

y = Volume flow V [l/min]
 x = Gap width f [μm]

6. Type number key

Type number key with selection example for AF 119143-711-53660/S4

Size

AF 11912	1 x 300x350	No. of steps x diameter x length [mm]
AF 11913	2 x 300x350	No. of steps x diameter x length [mm]
AF 11915	3 x 300x350	No. of steps x diameter x length [mm]
AF 11916	4 x 300x350	No. of steps x diameter x length [mm]

Cleaning drive

- 3** Gear motor 230/400 V, 50 Hz or 266/460 V, 60 Hz
- 4** Gear motor 230/400 V, 50 Hz Ex II 2G T3

Inlet and outlet connections

- 6** DN 100
- 7** DN 125
- 8** DN 150
- 9** DN 200

Permissible operating pressure in bar (housing/cover)

- 1** PN 10

Material Seal FPM, bearing PTFE

- 1** Standard; aluminium, nodular cast iron; steel
- 2** Stainless steel 1.4571/1.4581
- 3** Standard; steel, internals stainless steel 1.4301/1.4571

Differential pressure indicator and gauge

- 5** PiS 3175, digital Δp gauge, 2 pressure transmitters settable from 0 to 16 bar

Valves and control throttles

- 1** P2 control throttle with P2 gauge
- 6** Like 1 but with P3 control throttle and P3 gauge

Drain valve

- 2** Ball valve, electropneumatic 24 V
- 3** Ball valve, electropneumatic 230 V
- 4** Ball valve, electric 24 V
- 5** Ball valve, electric 230 V

Cleaning valve

- 2** Ball valve, electropneumatic 24 V
- 3** Ball valve, electropneumatic 230 V
- 4** Ball valve, electric 24 V
- 5** Ball valve, electric 230 V

Optional features

- 0** Without / special version

AF 11913 **3** **-7** **1** **1** **-5** **1** **2** **2** **0** **-XXXX (end number for special version)/S4**

*end number completion:

S4 welded, Version 4

End number	Special version
3001	Standard filter insert (complete), without housing or drive
3002	Standard complete inner assembly, without housing, with drive
3700	PTFE seals
Other numbers	On request

Type number key with selection example for coiled or welded cartridges for AF 1002013-006

Series

AF 100 Segmented element with topmesh

Material	Core element	Filter medium	Clamp rings
----------	--------------	---------------	-------------

Segmented element

20	Al/hc	1.4571	1.4571
21	1.4571	1.4571	1.4571

Overall length Diameter x length in mm

13 300 x 350

Gap width/rating in µm (see 4. Design and application)

001	10 µm	004	40 µm	010	100 µm
002	20 µm	006	60 µm		
003	30 µm	008	80 µm		

Other filter ratings on request

AF 100 20 13 -006

7. Spare parts

No.	Designation	Material no.	
		FPM/C steel	PTFE/VA
1	Bush kit		70310285
2	Seal kit (complete)	70310287	
3	Backflush channel moulding AF 119		70310292
4	Filter cartridge	See name-plate	

Please contact us for detailed technical information, any open questions about options, accessories and for general expert advice. Completion of the relevant questionnaire would facilitate in the coordination of all important parameters.

Comprehensive documentation on our filter range, filter elements and accessories can be provided. About installation and operation, please refer to the Instruction Manual