

Filter Aggregate

Pi 8200

Volume flow 14 and 35 l/min

1. Features

Compact, ready-to connect filter aggregates for modern hydraulic and lubrication systems

- Low noise internal gear pump with double bearing driving shaft
- Minimum loss of performance due to the high efficiency and the volume flow optimized design of parts
- Integrated pressure limitation valve
- Visual/electrical maintenance indicators
- Equipped with highly efficient Filtration Group Sm-x spin-on cartridges
- Beta rated elements according to ISO 16889 multipass test
- High dirt holding capacity due to the large filter surface
- Defined cleanliness classes
- Easy to service
- Worldwide distribution



2. Mode of operation

The filter assembly consists of a filter block with an integrated electric motor, a gear pump, a filter housing and a spin-on cartridge.

With its double-bearing drive shaft design, the internal-gear pump is extremely quiet and virtually vibration-free, with excellent suction capacity and sophisticated mechanical- and volumetric efficiencies. The Filtration Group spin-on cartridges can be supplied with filter ratings ranging from 3 µm to 25 µm and Sm-x assembly (β_{5(c)}) to β_{20(c)} according to ISO 16889) or with Mic elements with a nominal size of 10 and 25 µm.

In bypass mode, superior oil cleanliness codes per ISO 4406 of up to 14/12/09 and better can be achieved with these filter units and the Filtration Group Sm-x spin-on cartridges.

To monitor the filter element, a differential pressure indicator is supplied as standard. For customer-specific requirements, the entire range of Filtration Group differential pressure indicators is available with one or two switching levels, LED displays, various contact types, and connector plugs.

The pump units are suitable for all mineral-oil-based hydraulic oils and lubricating oils.

The standard scope of supply includes the complete unit with On/Off switch, motor protection feature, 2-m plug power cord, pump, maintenance indicator, and the selected spin-on cartridge.

Units are available for prompt delivery.

3. Separation grade characteristics

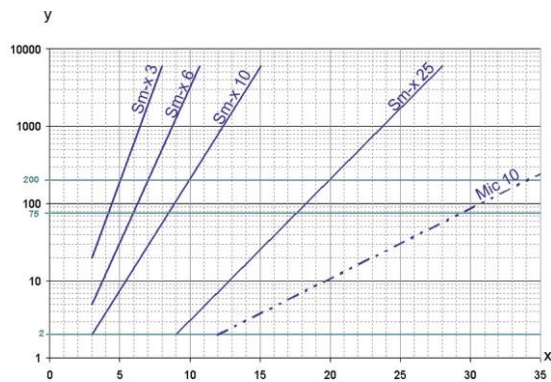

y = beta-value

x = particle size [µm]

determined by multipass tests (ISO 16889)

calibration according to ISO 11171 (NIST)

5. Quality assurance

Filtration Group filters and filter elements are produced according to the following international standards:

Norm	Designation
DIN ISO 2941	Hydraulic fluid power filter elements; verification of collapse/burst resistance
DIN ISO 2942	Hydraulic fluid power filter elements; verification of fabrication integrity
DIN ISO 2943	Hydraulic fluid power filter elements; verification of material compatibility with fluids
DIN ISO 3723	Hydraulic fluid power filter elements; method for end load test
DIN ISO 3724	Hydraulic fluid power filter elements; verification of flow fatigue characteristics
ISO 3968	Hydraulic fluid power-filters-evaluation of pressure drop versus flow characteristics
ISO 10771.1	Fatigue pressure testing of metal containing envelopes in hydraulic fluid applications
ISO 16889	Hydraulic fluid power filters-multipass method for evaluation filtration performance of a filter element

4. Filter performance data

tested according to ISO 16889 (multipass test)

Sm-x elements with max. Δ p 10 bar

Sm-x 3 β_{5(c)} ≥ 200

Sm-x 6 β_{7(c)} ≥ 200

Sm-x 10 β_{10(c)} ≥ 200

Sm-x 25 β_{20(c)} ≥ 200

values guaranteed up to 10 bar differential pressure

6. Symbols

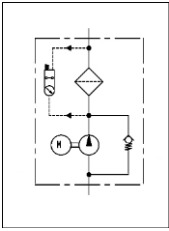

7. Order numbers

Example for ordering filters:

1. Filter aggregate	2. Spare part spin-on cartridge
V = 14 l/min with visual/electr. maintenance indicator and PX 33 spin-on cartridge Type: Pi 82001-069 PX33-13-2-Smx10 Order number: 70383014	Sm-x 10 Type: PX33-13-2-Smx10 Order number: 70541523

7.1 Filter aggregates			
Nominal size NG [l/min]	Order number	Type	with visual/electr. indicator
14	70383013	Pi 82001-069 PX33-13-2-Mic10	
	70383014	Pi 82001-069 PX33-13-2-Smx10	
	70383015	Pi 82001-069 PX37-13-2-Mic10	
	70383019	Pi 82001-069 PX37-13-2-Smx3	
	70383017	Pi 82001-069 PX37-13-2-Smx6	
	70320065	Pi 82001-069 PX37-13-2-Smx10	
	70383016	Pi 82001-069 PX37-13-2-Smx25	
35	70377257	Pi 82003-069 PX37-13-2-Mic10	
	70383025	Pi 82003-069 PX37-13-2-Smx3	
	70383024	Pi 82003-069 PX37-13-2-Smx6	
	70383023	Pi 82003-069 PX37-13-2-Smx10	
	70383022	Pi 82003-069 PX37-13-2-Smx25	

7.2 Spin-on cartridges					
Nominal size NG [l/min]	Order number	Type	Filter material	max. Δ p [bar]	Filter surface [cm ²]
14 + 35	70541525	PX33-13-2-Mic10	Mic 10	5	7000
	70541523	PX33-13-2-Smx10	Sm-x 10		3400
	70541540	PX37-13-2-Mic10	Mic 10		13500
	70541536	PX37-13-2-Smx3	Sm-x 3		7400
	70541537	PX37-13-2-Smx6	Sm-x 6		
	70541538	PX37-13-2-Smx10	Sm-x 10		
	70541539	PX37-13-2-Smx25	Sm-x 25		

8. Technical specifications

Pi 82001-069/Pi 82003-069

Volume flow:	14 l/min/35 l/min
Temperature range:	-10 to +80 °C
Setting pressure limiting valve:	4 ±0.5 bar
Maintenance indicator setting:	2.2 bar
Connection suction side:	G¾/G1
Connection pressure side:	G¾/G1
Motor output:	0.25 kW/0.55 kW
Revolutions:	1400 1/min
Voltage:	230V AC/50 Hz
Nominal current:	2.5 A/4.2 A
Type of protection:	IP 54 in inserted and secured status
Contact:	normally open/closed
Cable sleeve:	M20x1.5
Viscosity range:	10 – 200 mm²/s

The switching function can be changed by turning the electric upper part by 180° (normally closed contact or normally open contact). The state on delivery is a normally closed contact. By inductivity in the direct current circuit the use of suitable protection circuit should be considered. Further maintenance indicator details and designs are available in the maintenance indicator data sheet.

We draw attention to the fact that all values indicated are average values and do not always occur in specific cases of application. Our products are continually being further developed. Values, dimensions and weights can change as a result of this. Our specialized department will be pleased to offer you advice.

We recommend you to contact us concerning applications of our filters in areas governed by the EU Directive 94/9 EC (ATEX 95). The standard version can be used for liquids based on mineral oil (corresponding to the fluids in Group 2 of Directive 97/23 EC Article 9). If you consider to use other fluids please contact us for additional support.

Subject to technical alteration without prior notice!

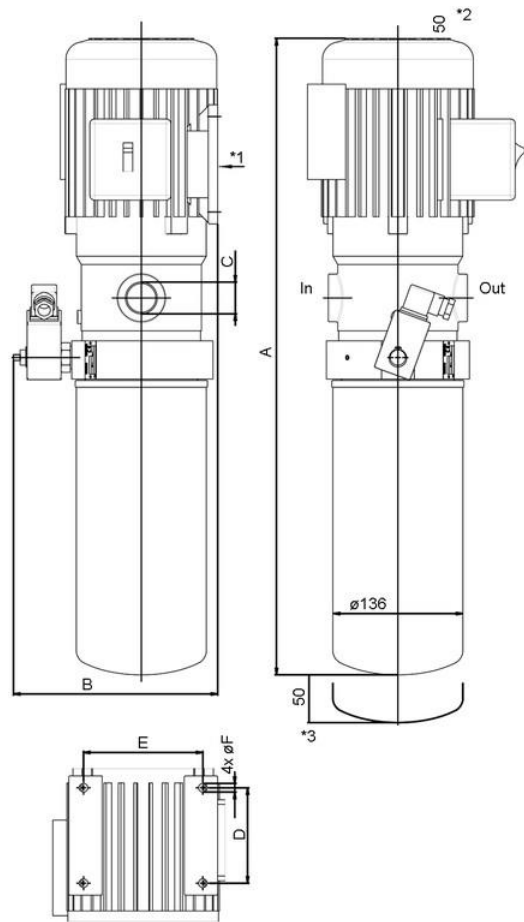

In	= Inlet
Out	= Outlet
*1	= View mounting
*2	= Minimum clearance
*3	= Clearance for cartridge change

9. Dimensions

All dimensions except "C" in mm.

Aggregate type	Spin-on cartridge type	A	B	C	D	E	F
Pi 82001-069	PX33	495	183	G $\frac{3}{4}$	90	112	7
	PX37	633	183	G $\frac{3}{4}$	90	112	7
Pi 82003-069	PX37	667	214	G1	100	125	9

10. Installation, operating and maintenance instructions

10.1 Filter aggregate installation

When installing the filter aggregate make sure that sufficient space is available to remove the spin-on cartridge. The filter aggregate should be installed with the spin-on cartridge pointing downwards.

The maintenance indicator must be visible.

10.2 Connecting the electrical maintenance indicator

The electrical indicator is connected via a 2-pole appliance plug according to DIN EN 175301-803 with poles marked 1 and 2.

The electrical section can be inverted to change from normally open position to normally closed position or vice versa.

10.3 When should the filter element be replaced?

1. Filter aggregates equipped with visual and electrical maintenance indicator:
During cold starts, the indicator may give a warning signal. Press the red button of the visual indicator once again only after operating temperature has been reached. If the red button immediately pops up again and/or the electrical signal has not switched off after reaching operating temperature, the filter element must be replaced after the end of the shift.
2. Filter aggregates without maintenance indicator:
The spin-on cartridge should be replaced after the trial run or flushing of the system. Afterwards follow instructions of the manufacturer.
3. Please always ensure that you have original Filtration Group spare spin-on cartridges in stock.

10.4 Spin-on cartridge exchange

1. Stop system and relieve filter aggregate from pressure.
2. Unscrew the spin-on cartridge with the aid of a belt spanner by turning some to the left.
3. Make sure that the order number on the spin-on cartridge corresponds to the order number of the plate.
4. The seal of the screw-on cartridge should be lightly oiled.
5. Screw cartridge on in accordance with the printed-on instructions.

11. Spare parts list

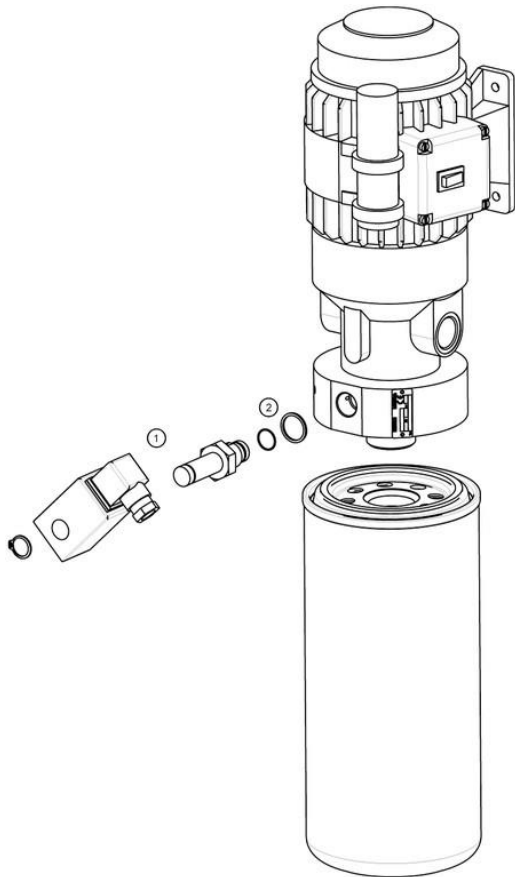

Order number for spare parts		
Position	Type	Order number
①	Maintenance indicator	
	Visual PiS 3098/2,2	77669971
	Electrical PiS 3097/2,2	77669948
	Electrical upper part only	77536550
②	Seal kit for maintenance indicator	
	NBR	77760309