

RES-5011

Operating instructions

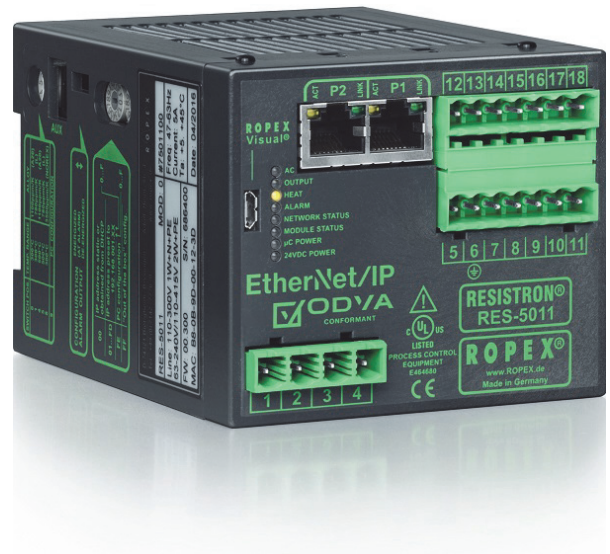

Important features

- Complete control via EtherNet/IP™ interface (2 x RJ-45)
- Automatic zeroing (AUTOCAL)
- Automatic optimisation (AUTOTUNE)
- Automatic configuration of the secondary voltage and current range (AUTORANGE)
- Automatic phase correction (AUTOCOMP)
- Automatic frequency adaptation
- Booster output
- Analogue output 0...10 VDC for ACTUAL temperature
- Alarm function with error diagnosis
- Heating element alloy and temperature range can be selected
- Wide voltage range for the use of 110...415 V
- Eight channels for administration of various calibration values
- Micro-USB interface for ROPEXvisual®
- cULus approval

Contents

1	Revision list	3	8	Device functions	20	
2	General information	3	8.1	LEDs and controls	20	
2.1	Copyright	3	8.2	EtherNet/IP™ communication	22	
2.2	Intended use	3	8.3	Device description file (EDS)	22	
2.3	Heatsealing band	4	8.4	Communication protocol	23	
2.4	Impulse transformer	4	8.5	Input data	23	
2.5	Current transformer PEX-W4/-W5	4	8.6	Output data	26	
2.6	Line filter	5	8.7	Parameter object (class: 0x0F)	28	
2.7	Standards / CE marking	5	8.8	Integrated web server	55	
2.8	Maintenance	5	8.9	Undervoltage detection	58	
2.9	Transportation	6	8.10	Temperature meter (actual value output)	59	
2.10	Disposal	6	8.11	Booster connection	60	
3	Use	6	8.12	USB interface for visualization software	ROPEXvisual®	61
4	Functional principle	7	8.13	AUX interface	61	
5	Device features	7	8.14	Total cycle counter	61	
6	Mounting and installation	8	8.15	Operating hours counter	61	
6.1	Installation sequence	8	8.16	Data memory for error messages and	AUTOCAL	62
6.2	Installation steps	9	8.17	Built-in clock (date and time)	62	
6.3	Power supply	10	8.18	System monitoring / alarm output ...	62	
6.4	Line filter	11	8.19	Error messages	63	
6.5	Current transformer PEX-W4/-W5 ...	11	8.20	Fault areas and causes	67	
6.6	Wiring diagram (standard)	13	9	Factory settings	69	
6.7	Wiring diagram with booster connection	14	10	Technical data	69	
7	Startup and operation	15	11	Dimensions	72	
7.1	View of the device	15	12	Modifications	72	
7.2	Device configuration	15	12.1	Modifications (MODs)	72	
7.3	Replacing and burning in the heatsealing	band	13	How to order	73	
7.4	Startup procedure	18	14	Index	75	

1 Revision list

Version	Change
1	<ul style="list-style-type: none"> • Creation of documentation
2	<ul style="list-style-type: none"> • Change to one column layout • ROPEX logo changed • Covering page with important features • Additions in general information <ul style="list-style-type: none"> ↳ section 2 "General information" on page 3 • Addition in Communication protocol: Status bit measurement interruption <ul style="list-style-type: none"> ↳ section 8.6.10 "Measurement interruption (MU)" on page 28 • Terminal number of analog output corrected <ul style="list-style-type: none"> ↳ section 8.7.8 "Automatic phase angle compensation (AUTOCOMP)" on page 50 • Extension of parameter object with instances 54 to 70: absolute calibration resistances <ul style="list-style-type: none"> ↳ page 42 • Extension integrated webserver: presentation of calibration values <ul style="list-style-type: none"> ↳ section 8.8.6 "Calibration page" on page 58 • Updating of how to order <ul style="list-style-type: none"> ↳ section 13 "How to order" on page 73

2 General information

This RESISTRON® temperature controller is manufactured according to EN 61010-1. In the course of its manufacture it passed through quality assurance, whereby it was subjected to extensive inspections and tests. As a result of this, the product left our factory in perfect condition.

Please carefully read through the operating manual before using the RESISTRON® temperature controller. Keep the operating manual for later reference and make sure that information and functions important for the user are available.

The recommendations and warning notes contained in these operating instructions must be complied with, in order to guarantee safe operation.

The device can be operated within the limits indicated in the "Technical Data" without impairing its operational safety. Installation and maintenance may only be performed by technically trained, skilled persons who are familiar with the associated risks and warranty provisions.

2.1 Copyright

All contents, in particular texts, photographs and graphics, are protected by copyright. All rights, including to replication, publication, editing and translation, are reserved.

2.2 Intended use

RESISTRON® temperature controllers may only be used for heating and temperature control of heatsealing bands which are expressly approved for them, and providing the regulations, notes and warnings contained in these instructions are observed.

In case of non-observance or use contrary to the intended purpose, there is a risk that safety will be impaired or that the heatsealing band, electrical wiring, transformer etc. will overheat. This is the personal responsibility of the user.

2.3 Heatsealing band

The use of suitable heatsealing bands is a basic prerequisite for reliable and safe operation of the system. The resistance of the heatsealing band which is used must have a positive minimum temperature coefficient in order to guarantee trouble-free operation of the RESISTRON[®] temperature controller.

The temperature coefficient must be specified as follows:

$$TCR = 10 \times 10^{-4} \text{K}^{-1} \text{ or } \text{K}^{-1} \text{ or ppm/K}$$

e.g. Alloy-20: TCR = 1100 ppm/K
NOEX: TCR = 3500 ppm/K
Vacodil: TCR = 1100 ppm/K

The RESISTRON[®] temperature controller must be set and coded according to the temperature coefficient of the heatsealing band.

The temperature coefficient must be taken from the ROPEX application report and must be set accordingly.

 **The use of incorrect alloys with a too low temperature coefficient and incorrect coding of the RESISTRON[®] temperature controller leads to uncontrolled heating of the heatsealing band, which will ultimately burn out!**

The original heatsealing bands must be clearly identified by means of suitable markings as well as the connector geometry, length, or other means to ensure that replacement bands are identical.

2.4 Impulse transformer

A suitable impulse transformer is necessary in order to guarantee trouble-free operation of the control loop. This transformer must be designed according to EN 61558 (isolating transformer with reinforced insulation) and have a one section bobbin. When the impulse transformer is installed, suitable touch protection must be provided in accordance with the national installation regulations for electrical equipment. In addition to this, water, cleaning solutions and conductive fluids must be prevented from seeping into the transformer.

Incorrect installation of the impulse transformer impairs electrical safety.

2.5 Current transformer PEX-W4/-W5

The current transformer supplied with the RESISTRON[®] temperature controller is an integral part of the control system.

Only the original ROPEX PEX-W4 or PEX-W5 current transformer may be used. Other transformers may cause the equipment to malfunction.

The current transformer may only be operated if it is correctly connected to the RESISTRON[®] temperature controller (see section "Startup and operation"). The relevant safety instructions contained in section "Power supply", must be observed. External monitoring modules can be used in order to additionally increase operating safety. They are not included in the scope of supply of the standard control system and are described in a separate document.

2.6 Line filter

ROPEX provides line filters in different power classes. The ROPEX application report lists the suitable line filter which can be ordered accordingly.

The use of an original ROPEX line filter is mandatory in order to comply with the standards and provisions mentioned in section 2.7 "Standards / CE marking" on page 5. This device must be installed and connected according to the instructions contained in section "Power supply" as well as the separate documentation enclosed with the line filter.

2.7 Standards / CE marking

The controller described here complies with the following standards, provisions and directives:

DIN EN 61010-1:2001 (2014/35/EU)	Safety requirements for electrical equipment for measurement, control and laboratory use (low-voltage directive): pollution degree 2, protection class I, measurement category I (for U_R and I_R terminals)
DIN EN 60204-1 (2006/42/EG)	Electrical equipment of machines (machinery directive)
EN 55011:2009+A1:2010 EN 61000-3-2:2006-04+A1:2009+A2:2009 EN 61000-3-3:2008 EN 61000-6-4:2007+A1:2011 (2014/30/EU)	EMC generic emissions: Group 1, Class A
EN 61000-6-2:2005 (2014/30/EU)	EMC generic immunity: Class A (ESD, RFI, burst, surge) <u>Exception:</u> Line voltage interruption acc. to EN 61000-4-11 is not fulfilled (this leads to a designated error message of the controller)
2011/65/EU	Directive on the restriction of the use of certain hazardous substances in electrical and electronic equipment.

Compliance with these standards and provisions is only guaranteed if original accessories and / or peripheral components approved by ROPEX are used. If not, then the equipment is operated on the user's own responsibility. The CE marking on the controller confirms that the device itself complies with the above-mentioned standards.

It does not imply, however, that the overall system also fulfills these standards.

It is the responsibility of the machine manufacturer and of the user to verify the completely installed, wired and operationally ready system in the machine with regard to its conformity with the safety provisions and the EMC directive (see also section "Power supply"). If peripheral components (e.g. the transformer or the line filter) from other manufacturers are used, no functional guarantee can be provided by ROPEX.

2.8 Maintenance

The controller requires no special maintenance. Regular inspection and / or tightening of the terminals – including the terminals for the winding connections on the impulse transformer – is recommended. Dust deposits on the controller can be removed with dry compressed air.

 **Dust deposits and dirt from liquids result in a loss of function. Accordingly, installation in a switch cabinet or terminal cabinet with IP54 is recommended.**

2.9 Transportation

Store and transport the device in its original carton.
After transport, perform a visual inspection for possible damage.

2.10 Disposal



This device is subject to Directive 2012/19/EU concerning the reduction of the increasing amount of waste electrical and electronic equipment and the disposal of such waste in an environmentally sound way.

To guarantee proper disposal and / or the recover of reusable material, please take the device to a designated municipal collection point and observe local regulations.

 Careless, uncontrolled disposal can cause damage to the environment and human health. By ensuring that your product is disposed of or recycled in a responsible way, you can help protect the environment and human health.

 **This device must not be disposed of as residual waste!**

3 Use

This RESISTRON[®] temperature controller is part of the “Series 5000”, whose main characteristic is microprocessor technology. All RESISTRON[®] temperature controllers provide temperature regulation of heating elements as are used in a variety of foil sealing processes.

The most common heating elements include:

- ribbon cables (straight and contoured)
- clincher bands
- beaded bands
- cutting wires
- heat-sealing blades
- soldering bows

The main application area is sealing or cutting of thermoplastics using the thermal impulse process.

The most common application areas are:

- vertical and horizontal form-fill-seal machines (VFFS and HFFS)
- bagging, filling and sealing machines
- film-wrapping machines
- bag-production machines
- group packaging machines
- foil sealing devices
- spout and hose sealing
- and much more

4 Functional principle

The resistance of the heating element, which changes with temperature, is measured by means of current and voltage measurement, displayed and compared with the specified setpoint value. Measurements are made 50 times per second in a 50 Hz network, 60 times per second in a 60 Hz network.

The primary voltage of the impulse transformer is adjusted following the leading edge principle if the measured values deviate from the setpoint value. The related current change in the heating element results in a rise in temperature and change of resistance. The change in resistance is measured and evaluated by the RESISTRON[®] temperature controller. The temperature controller adjusts the control variables according to the change and the setpoint.

Even the smallest thermal loads on the heating element are recorded and can be quickly and precisely corrected. Measurement of pure electric variables, together with the high measurement rate, result in a highly dynamic thermoelectric control circuit. The principle of primary-side transformer control proves to be especially advantageous as it permits a very large secondary current range with low power loss. This permits an optimal adjustment to the load and thus the desired dynamics with extremely compact device measurements.

5 Device features

The RESISTRON[®] temperature controller RES-5011 is equipped with a EtherNet/IP[™] interface. Through this interface, all functions and parameters can be parameterised by means of the higher level machine controller. In addition, important controller information is queried and can be processed accordingly.

The ACTUAL temperature of the heating element is output through the EtherNet/IP[™] interface and through an analogue output 0...10 VDC. The real heating element temperature can be visualised on an external display instrument (e.g. ATR-x) or via the operating unit of the machine controller.

The RES-5011 has an integrated error diagnosis that checks both the external system (heating element, wiring, etc.) and the internal electronics. A differentiated error message is output through the EtherNet/IP[™] interface in case of malfunction.

To increase operational security and immunity to interference, all EtherNet/IP[™] signals from the controller and heating circuit are electrically isolated.

Adjustment for different heating element alloys (alloy A20, Vacodil, etc.) and setting of the temperature range to be used (0...300 °C or 0...500 °C) can be made through coding switches on the temperature controller itself or through the EtherNet/IP[™] interface.

The compact design of the RESISTRON[®] temperature controller RES-5011 as well as the plug-in connecting terminals make mounting and installation easier.

An overview of the most important features and functions:

- Easy calibration of the heating element through AUTOCAL, the automatic zero-point setting.
- Eight channels permit switching of the calibration parameters during tool change.
- High control dynamics through AUTOTUNE, automatic adjustment to the controlled system.
- High flexibility: The AUTORANGE function covers a secondary voltage range of 0.4 V to 120 V and a current range of 30 A to 500 A.
- Automatic adjustment to the network frequency in the range of 47 Hz to 63 Hz.
- Wide voltage range for flexible use from 110 VAC to 415 VAC
- Easy and convenient system diagnosis and process visualisation through the free, downloadable software ROPEXvisual[®]
- Comprehensive error diagnosis over the EtherNet/IP[™] interface
- Booster output available for connecting a switching amplifier
- High process security through comprehensive options for evaluating the parameter data (e.g. temperature diagnosis or heat-up time monitoring)

6 Mounting and installation

↪ See also section 2 "General information" on page 3.

 **Mounting, installation and startup may only be performed by authorized persons who have received suitable instruction and are familiar with the associated risks and warranty provisions.**

 **The supply voltage to the machine side must lie within the permitted voltage and frequency range of the RESISTRON[®] temperature controller. Otherwise, there is the danger of a defect.**

6.1 Installation sequence

Proceed as follows to install the RESISTRON[®] temperature controller RES-5011:

1. Switch off the line voltage and the 24 VDC supply, and verify that the circuit is de-energized.
2. Mount the RESISTRON[®] temperature controller on a standard top hat rail (DIN TS35 rail according to DIN EN 50022) in the electrical cabinet. If several controllers are mounted on one rail, the minimum clearance specified in section 10 "Technical data" on page 69 must be allowed between them.
3. Wire the system in accordance with the instructions in section 6.3 "Power supply" on page 10, section 6.6 "Wiring diagram (standard)" on page 13, and the ROPEX Application Report. The information provided in section 6.2 "Installation steps" on page 9 must also be observed.

Wires used for control or measuring connections must always be laid inside the building.

4. An overcurrent protective device with a maximum rating of 10 A must be fitted when the device is installed, e.g.:
 - Miniature circuit breaker to EN 60898 (B, C, D, K, or Z characteristic)
 - Miniature circuit breaker to UL 489 (*) (B, C, D, K, or Z characteristic)
 - Fuse gG to IEC 60269
 - Class CC or Class J fuse to UL 248 (*)

The overcurrent protective devices marked (*) should be used in installations conforming to UL standards.

If one such device is not adequate for the heatsealing application, two separate overcurrent protective devices should be provided – one for the controller and one for the application (↪ ROPEX Application Report).

The overcurrent protective device must be located directly adjacent to the controller.

The minimum possible specification for this device is indicated in the ROPEX Application Report based on the calculated currents. If a larger overcurrent protective device is fitted, you must match the current carrying capacity of the other components accordingly (e.g. cables, impulse transformer etc.).

5. A disconnecting device must be provided when the system is installed; it must be marked as belonging to the system and fitted in a readily accessible position.

If a miniature circuit breaker is used, it can also perform the function of this device.
6. Connect the RESISTRON[®] temperature controller to the EtherNet/IP[™] scanner using a suitable (standard compliant) cable.

 **Check that all system connections – including the terminals for the impulse transformer windings – are securely attached.**

7. Make sure the wiring conforms to all relevant national and international installation regulations.

6.2 Installation steps

Sample depiction

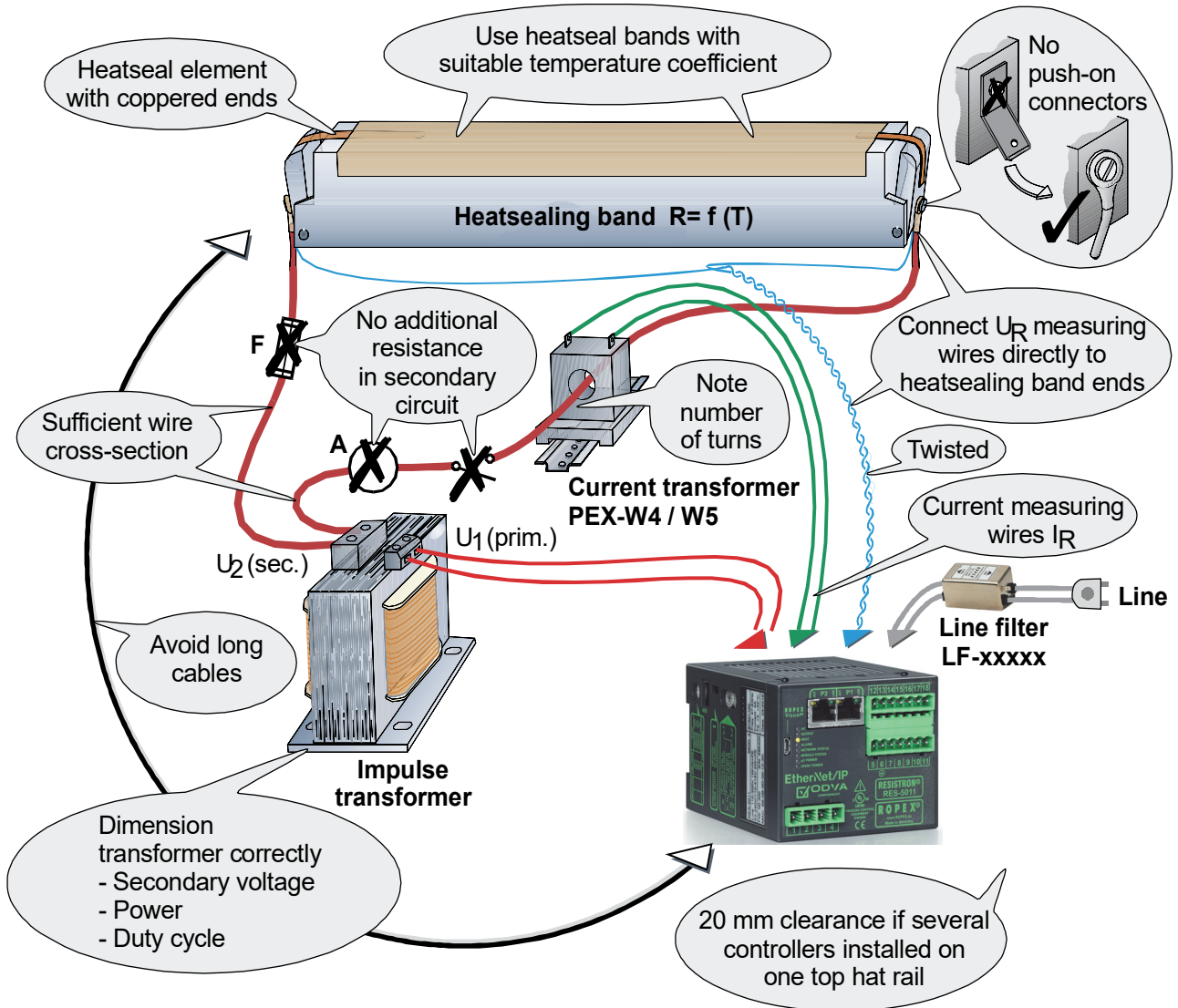

6.3 Power supply

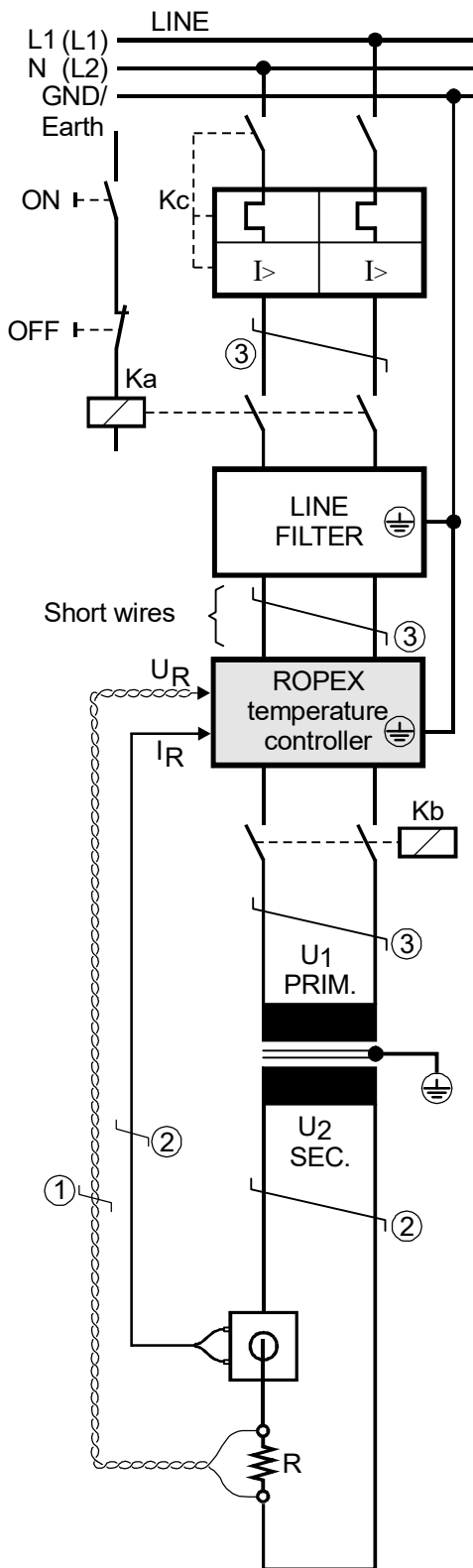

Line

Over-current protection

Double-pole circuit-breaker or fuses,
(☞ ROPEX Application Report)

⚠ Short-circuit protection only. RESISTRON® temperature controller not protected.

Relay Ka

For "HEAT ON - OFF" function (all-pole) or "EMERGENCY STOP".

Line filter

The filter type and size must be determined according to the load, the transformer and the machine wiring (☞ ROPEX Application Report).

⚠ Do not run the filter supply wires (line side) parallel to the filter output wires (load side).

RESISTRON® temperature controller

Relay Kb

Load break (all-pole), e.g. in combination with the alarm output of the temp. controller (ROPEX recommendation).

⚠ When using a series resistor RV-....-1 the relay Kb shall be installed.

Impulse Transformer

Designed according to EN 61558 (isolating transformer with reinforced insulation). Connect core to ground.

⚠ Use transformers with a one section bobbin. The power, duty cycle and voltage values must be determined individually according to the application (☞ ROPEX Application Report and "Accessories" leaflet for impulse transformers).

Wiring

The wire cross-sections depend on the application (☞ ROPEX Application Report).

① Wires must always be twisted (min. 20 turns/meter).

② These wires must be twisted (min. 20 turns/meter) if several control loops are laid together ("crosstalk").

③ Twisting (min. 20 turns/meter) is recommended to improve EMC.

6.4 Line filter

To comply with EMC directives – corresponding to EN 50081-1 and EN 50082-2 – RESISTRON control loops must be operated with line filters.

These filters damp the reaction of the phase-angle control on the line and protect the controller against line disturbances.



The use of a suitable line filter is part of the standards conformity and a prerequisite of the CE mark.

ROPEX line filters are specially optimized for use in RESISTRON control loops. Providing that they are installed and wired correctly, they guarantee compliance with the EMC limit values.

You can find the exact specification of the line filter in the ROPEX Application Report calculated for your particular heatsealing application.

For more technical information: ↪ "Line filter" documentation.

It is permissible to supply several RESISTRON control loops with a single line filter, providing the total current does not exceed the maximum current of the filter.

The wiring instructions contained in section 6.3 "Power supply" on page 10 must be observed.

Example drawing for LF-06480:

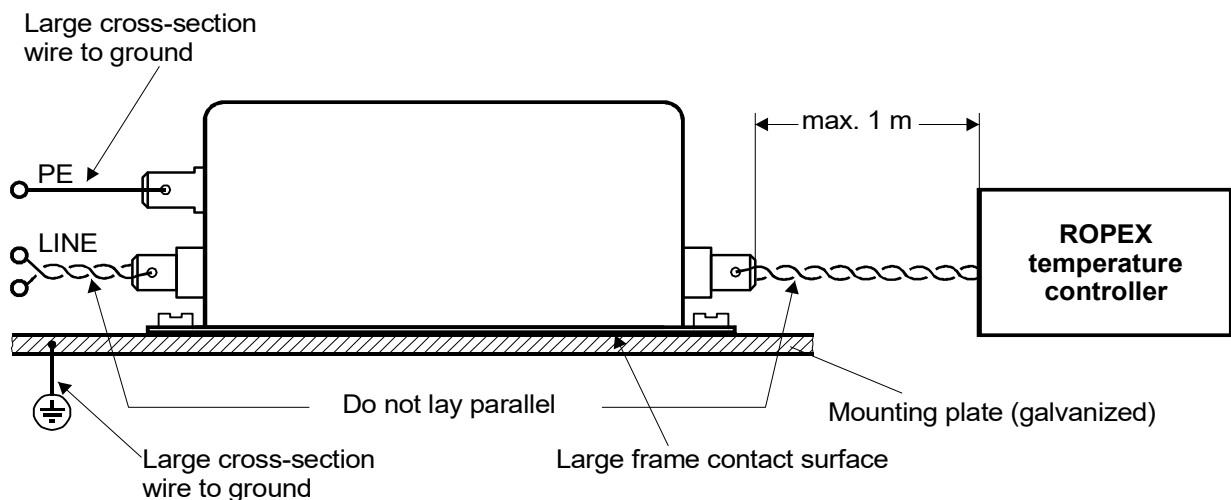

6.5 Current transformer PEX-W4/-W5

The PEX-W4/-W5 current transformer supplied with the RESISTRON[®] temperature controller is an integral part of the control system. The current transformer may only be operated if it is connected to the temperature controller correctly (↪ section 6.3 "Power supply" on page 10).

6.5.1 PEX-W4

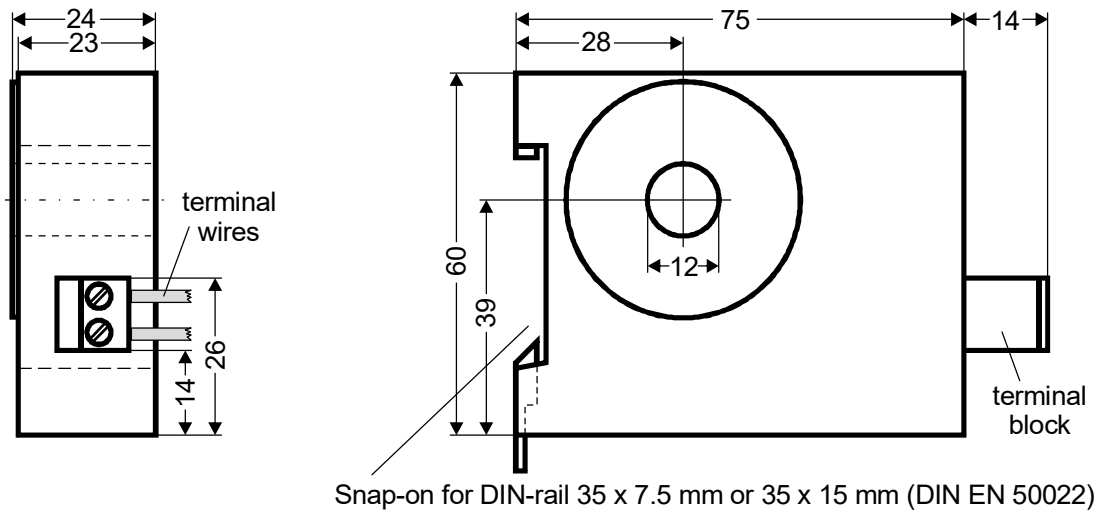

6.5.2 PEX-W5

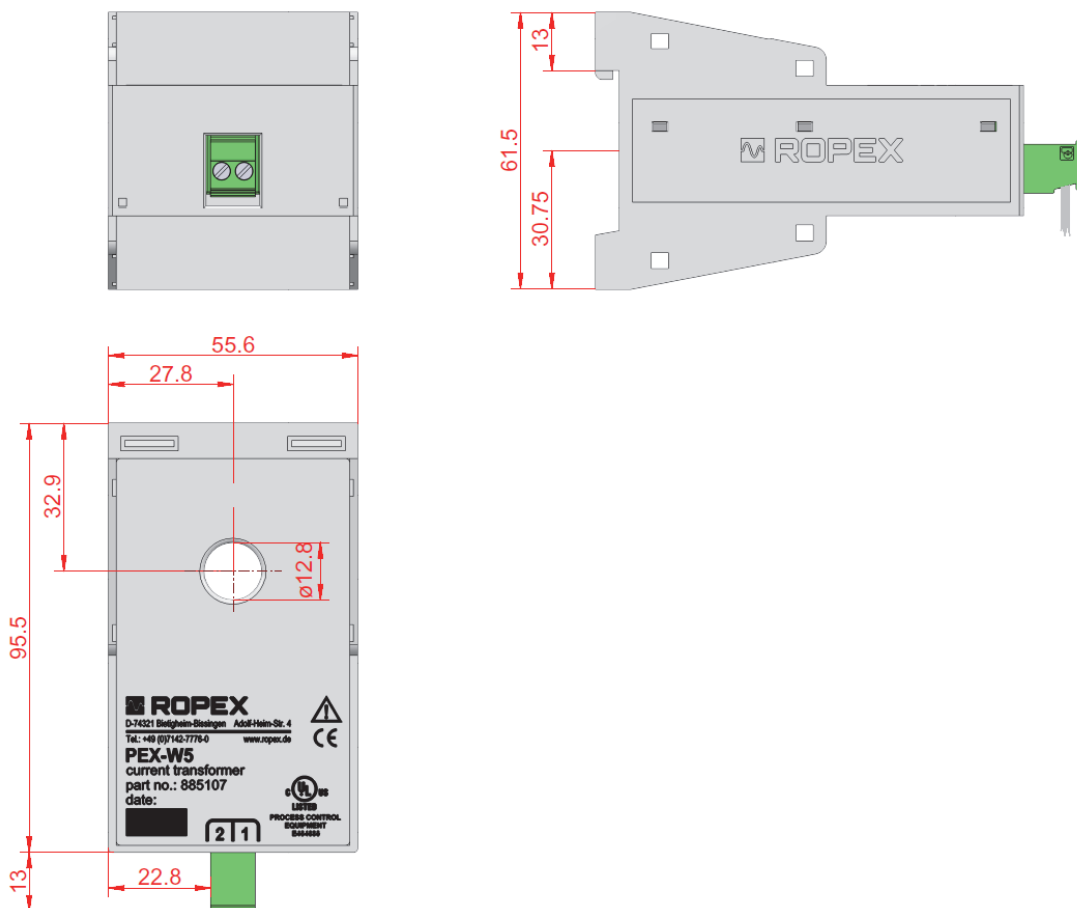

Mounting on DIN-rail 35 x 7.5 mm or 35 x 15 mm (DIN EN 50022).

6.6 Wiring diagram (standard)

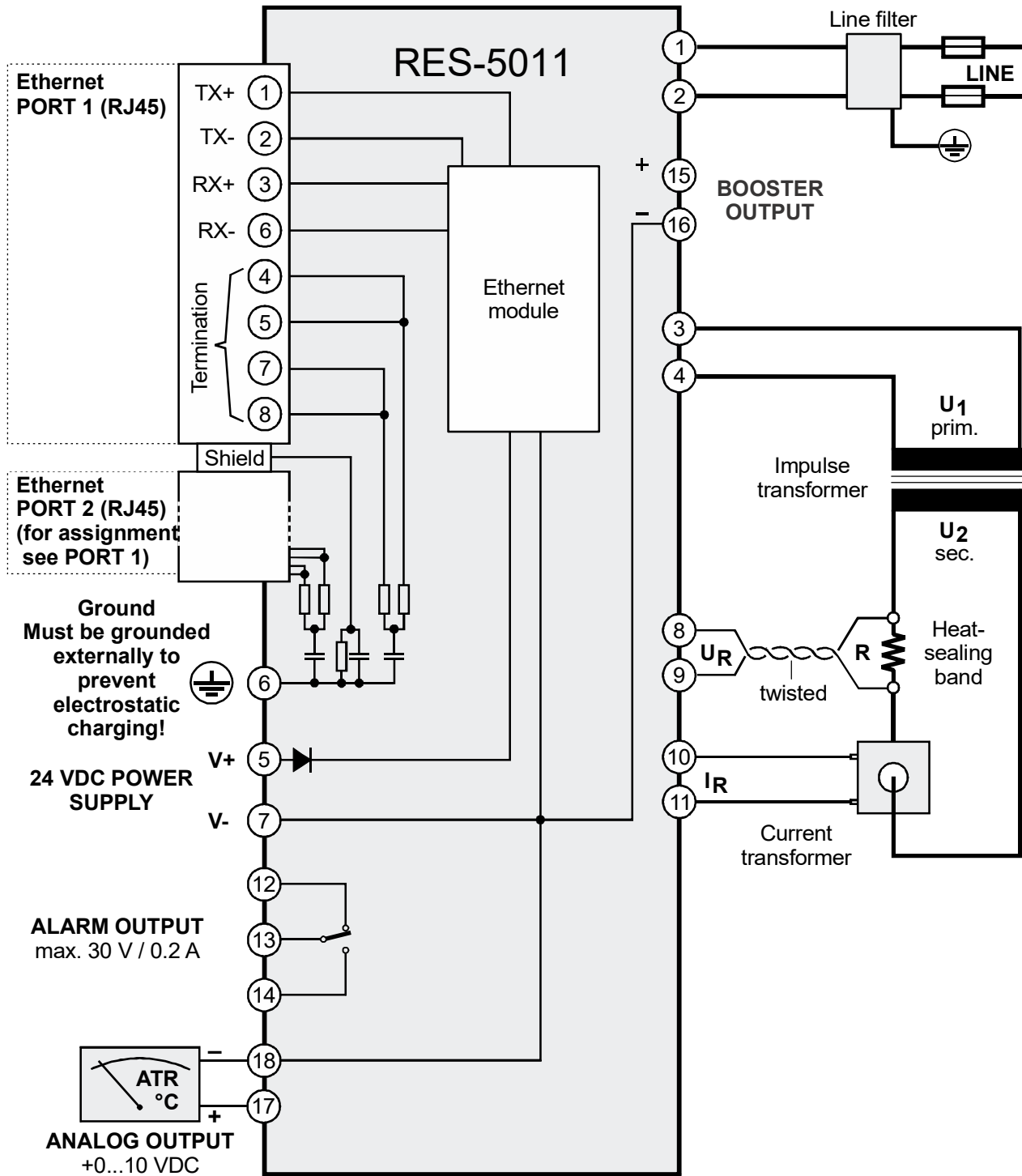

6.7 Wiring diagram with booster connection

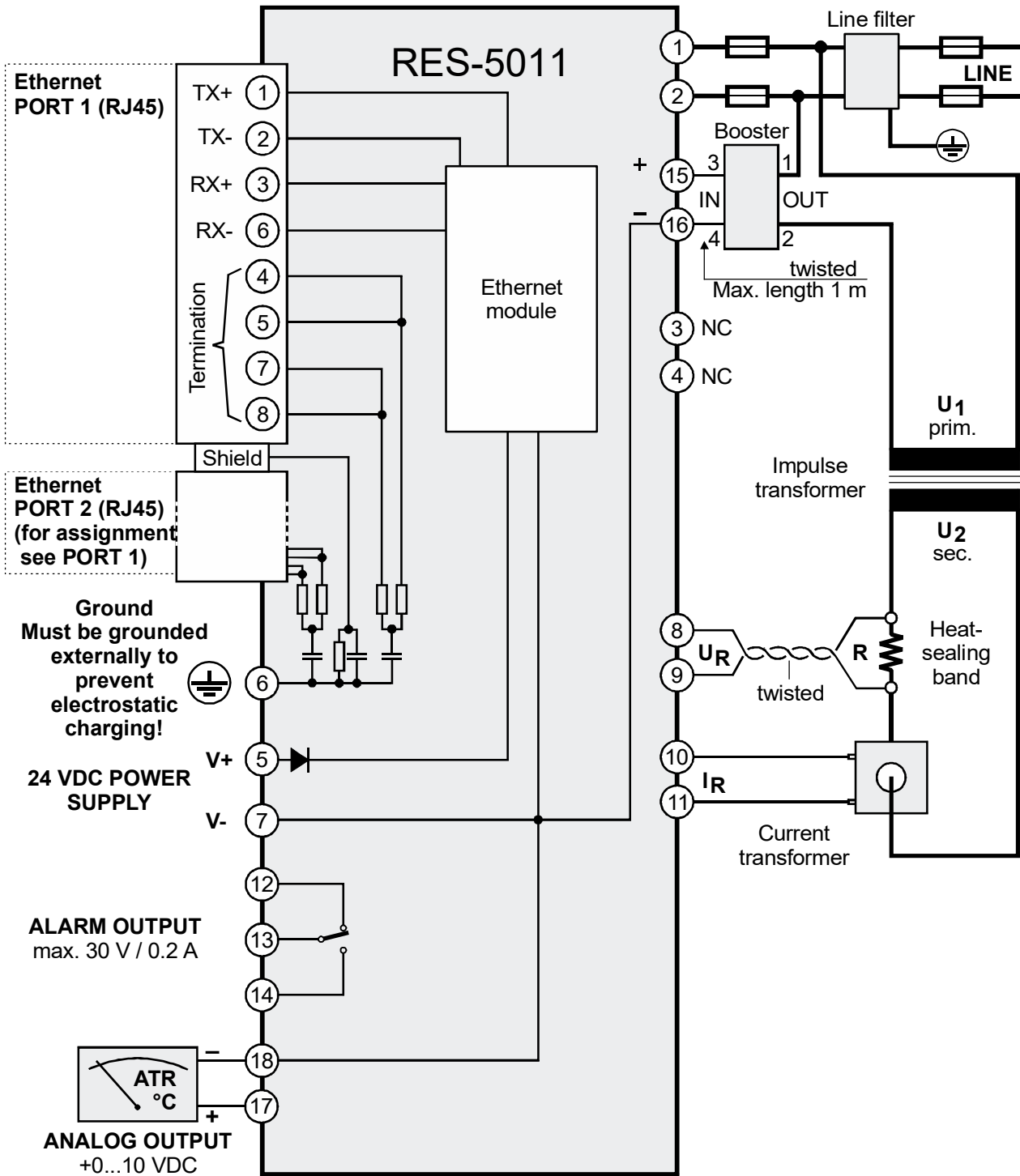

7 Startup and operation

7.1 View of the device

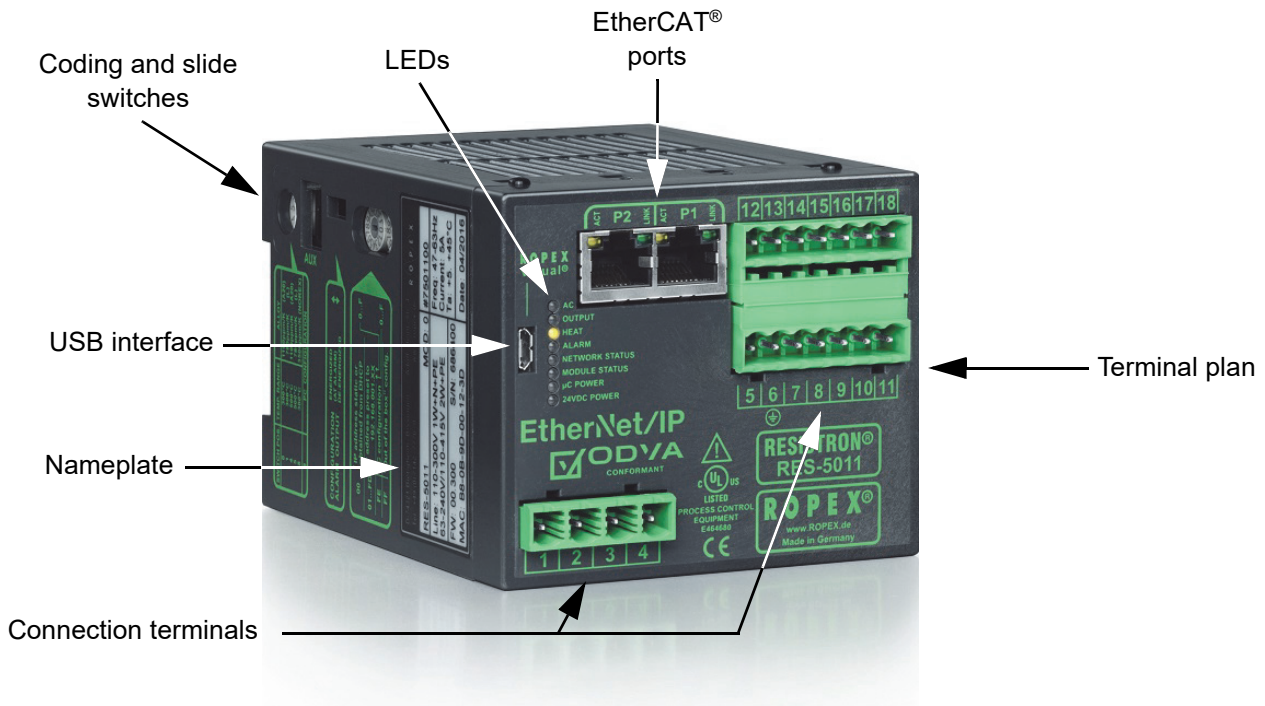

7.2 Device configuration



The controller must be switched off in order to configure the coding and slide switches.

7.2.1 Configuration of the secondary voltage and current ranges

The secondary voltage and current ranges are automatically configured during the automatic calibration function (AUTOCAL). The voltage is configured in the range from 0.4 VAC to 120 VAC and the current in the range from 30 A to 500 A. If the voltage and / or current are outside of the permissible range, a detailed error message appears on the controller (↪ section 8.19 "Error messages" on page 63).

If the secondary current I_2 is less than 30 A, the secondary high-current wire must be laid twice (or several times) through the PEX-W4, or PEX-W5 current transformer (↪ ROPEX Application Report).



7.2.2 Configuration of the rotary coding switch for the temperature range and alloy

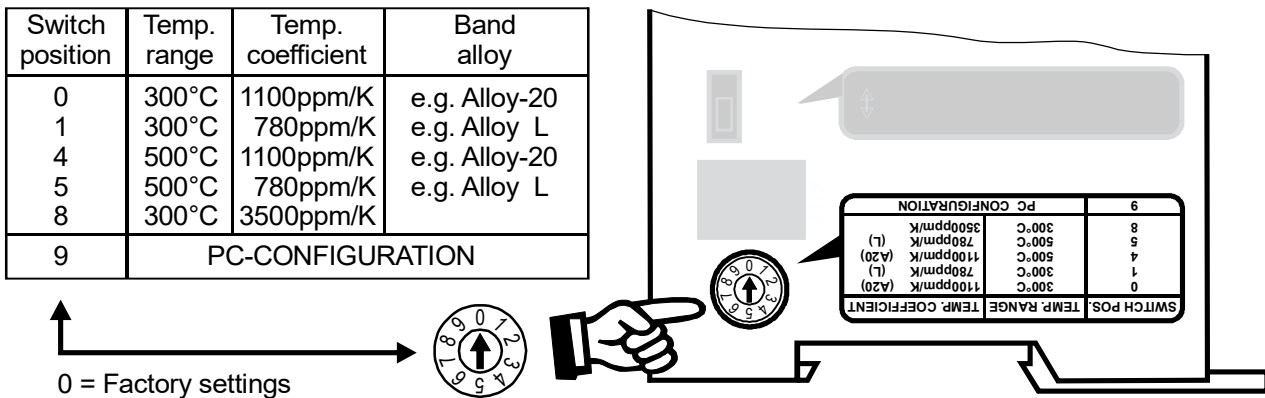

! The setting of the rotary coding switch for the temperature range and alloy can be overwritten with the parameter data (↪ section 8.7 "Parameter object (class: 0x0F)" on page 28).

If the switch is set to "9", more temperature ranges and alloys can be selected in the ROPEX visualization software (↪ section 8.12 "USB interface for visualization software ROPEXvisual®" on page 61).

7.2.3 Configuration of the rotary coding switch for the IP address

These coding switches allow you to set the least significant byte in the IP address of the RES-5011 in the EtherNet/IP™ network to a value between 0x01 and 0xFD. A new setting does not take effect until the next time the controller is switched on. The preset IP address of the RES-5011 is configured as follows, depending on the settings of the rotary coding switches:

Rotary coding switch	IP address
00	DHCP client active or if DHCP client was deactivated: Last IP address assigned is static
01...FD	192.168.001.1...253
FE	Configuration determined by PC visualization software
FF	Last configuration assigned is erased

IP address selectable.

00 = Factory settings

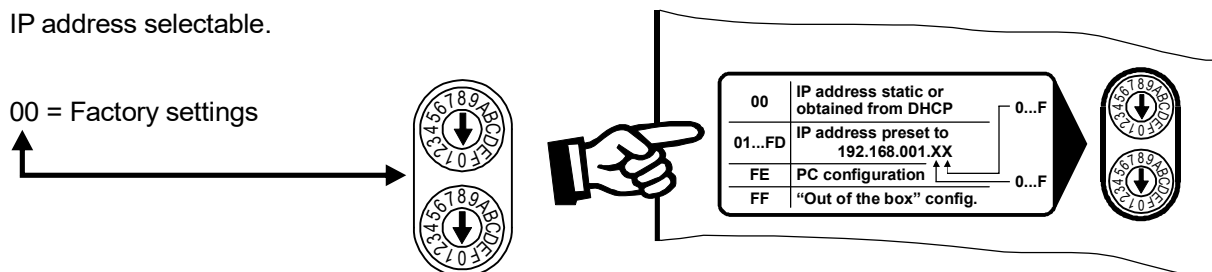

The "00" switch position allows an IP address to be assigned, or the DHCP client switched on and off, via the EtherNet/IP™ interface either using a software tool (e.g. Rockwell's "BOOT / P-DHCP Server") or by manually accessing the TCP / IP object. These settings are stored in the controller. However, when the power supply to the controller is momentarily interrupted, the stored values are only used if the rotary coding switches are set to "00". All other switch positions cause the stored values to be temporarily overwritten.

7.2.4 Configuration of the alarm relay

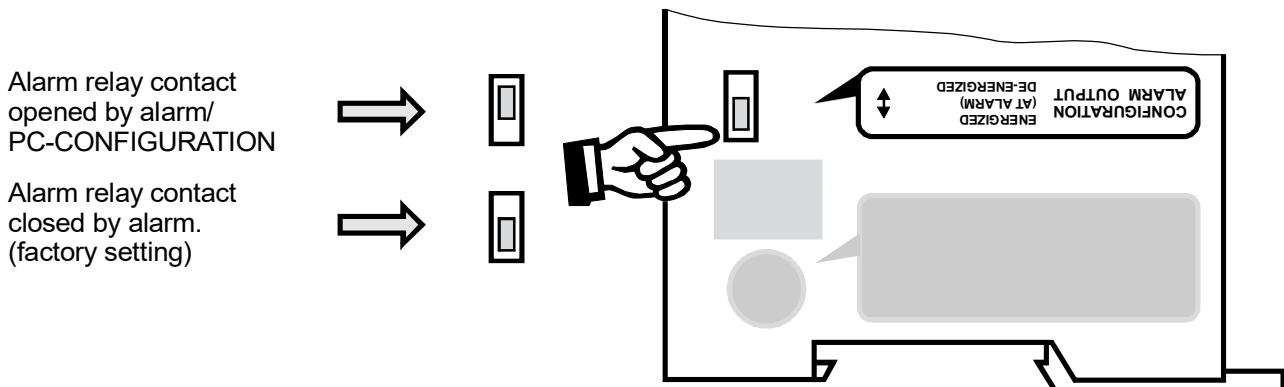

If the switch is set to "Alarm relay de-energized at alarm / PC CONFIGURATION", you can select more alarm output configurations in the ROPEX visualization software (see section 8.12 "USB interface for visualization software ROPEXvisual[®]" on page 61).

7.3 Replacing and burning in the heatsealing band

7.3.1 Burning in the heatsealing band

The heatsealing band is a key component in the control loop because it is not only a heating element but also a sensor. The geometry of the heatsealing band is too complex to be discussed at length here. We shall therefore only refer to a few of the most important physical and electrical properties.

The measuring principle used for this system requires a heatsealing band alloy with a suitable temperature coefficient TCR. Too low a TCR leads to oscillation or uncontrolled heating.

If a heatsealing band with a higher TCR is used, the controller must be calibrated for it.

The first time the heatsealing band is heated to approximately 200...250 °C, the standard alloy undergoes a once-only resistance change (burn-in effect). The cold resistance of the heatsealing band is reduced by approximately 2...3%. However, this at first glance slight resistance change results in a zero point error of 20...30 °C. The zero point must therefore be corrected after a few heating cycles, i.e. the AUTOCAL function must be run again.

To do this, the system must be cooled off completely.

After the first heating and zeroing, the heating element is burned in and the change of resistance stabilised. The heating element can now be used.

The burn-in effect described here does not occur if the heatsealing band has already been thermally pretreated by the manufacturer.

⚠ An overheated or burned-out heatsealing band must no longer be used because the temperature coefficient has been irreversibly altered.

A very important design measure is copper-coating or silver-coating of the heating element ends. The thermal characteristics change in this range through coating of the heating element ends. As a result, the ends remain cold, which permits exact temperature control and increases the useful life of the heating element.

7.3.2 Replacing the heatsealing band

The supply voltage (all poles) must be disconnected from the RESISTRON[®] temperature controller in order to replace the heatsealing band.

⚠ The heatsealing band must be replaced in accordance with the instructions provided by the manufacturer.

Each time the heatsealing band is replaced, you must calibrate the zero point with the AUTOCAL function while the band (and the environment, i.e. silicone, PTFE cover, sealing bar etc.) is still cold in order to compensate production-related resistance tolerances.

If a new heating element is used, the above-described procedure for burning in must be performed.

7.4 Startup procedure

Please also refer to section 2 "General information" on page 3 and section 3 "Use" on page 6.



Mounting, installation and startup may only be performed by authorized persons who have received suitable instruction and are familiar with the associated risks and warranty provisions.

7.4.1 Initial startup

Condition: The device must be correctly installed and connected (↪ section 6 "Mounting and installation" on page 8).

Proceed as follows to start up the controller for the first time:

1. Switch off the line voltage and the 24 VDC supply, and verify that the circuit is de-energized.
2. Set the IP address of the device either by means of the rotary coding switches or a DHCP server (↪ section 7.2 "Device configuration" on page 15).
3. Link the device description file (EDS) into the EtherNet/IP™ scanner (↪ section 8.3), then select the required parameters, make the connections, assign an IP address, and start the communication.
4. Make sure that the higher-level controller does not send values not equal to zero to the temperature controller.
5. Switch on the line voltage and the 24 VDC supply (the order is arbitrary).
6. When the voltage is switched on, the yellow "AUTOCAL" LED lights up for approximately 0.3 seconds to indicate that the controller is being powered up correctly.



If the red "ALARM" LED lights up for 0.3...1.5 seconds when the voltage is switched on in addition to the yellow "AUTOCAL" LED, the configuration of this controller has been changed in the visualization software (↪ section 8.12 "USB interface for visualization software ROPEXvisual®" on page 61). In order to avoid malfunctions, please check the controller configuration before continuing the startup procedure.

7. One of the following states then appears:

"ALARM" LED	"OUTPUT" LED	ACTION
OFF	Short impulses every 1.2 s	Go to step 8
BLINKS fast (4 Hz)	OFF	Go to step 8
LIT continuously	OFF	Error diagnosis (↪ section 8.19)

8. Activate the AUTOCAL function while the heatsealing band is still cold by setting the AC bit (**A**UTOCAL) in the EtherNet/IP™ protocol (↪ section 8.4 "Communication protocol" on page 23). The yellow "AUTOCAL" LED lights up for the duration of the calibration process (approx. 10...15 seconds). The AA bit (**A**UTOCAL **a**ctive) is additionally set and a voltage of approximately 0 VDC appears at the actual value output (terminals 17+18). If an ATR-x is connected, it indicates 0...3 °C.

After the zero point has been calibrated, the "AUTOCAL" LED goes out and a voltage of 0.66 VDC (300 °C range) or 0.4 VDC (500 °C range) appears at the actual value output. If an ATR-x is connected, it must be set to "Z".

If the zero point was not calibrated successfully, the AL bit (**a**larm **a**ctive) is set and the red "ALARM" LED blinks

slowly (1 Hz). In this case the controller configuration is incorrect (↪ section 7.2 "Device configuration" on page 15, ROPEX Application Report). Repeat the calibration after correcting the controller configuration.

9. After the zero point has been successfully calibrated, specify a defined temperature by means of the EtherNet/IP™ protocol (set point) and set the ST bit. The RA bit (control active) is then activated and the "HEAT" LED lights up. The heating and control process can be observed at the actual value output.

The controller is functioning correctly if the temperature (which corresponds to the signal change at the analog output or the actual value in the EtherNet/IP™ protocol) is a regular curve, in other words it must not jump abruptly, fluctuate, or temporarily deviate in the wrong direction. This kind of behavior would indicate that the U_R measurement cable was laid incorrectly.

If an error code is displayed, proceed as described in section 8.19 "Error messages" on page 63.

10. Burn in the heatsealing band (↪ section 7.3 "Replacing and burning in the heatsealing band" on page 17) and run the AUTOCAL function again.

7.4.2 Restart after replacing the heatsealing band

To replace the heatsealing band, proceed as described in section 7.3 "Replacing and burning in the heatsealing band" on page 17.



Always use a heatsealing band with the correct alloy, dimensions, and copper plating in order to avoid malfunctions and overheating.

Continue with section 7.4, steps 4 to 10.

8 Device functions

See also section 6.6 "Wiring diagram (standard)" on page 13.

8.1 LEDs and controls

RX/TX (yellow LED)	Lit or blinking if Ethernet frames are transmitted.
LINK (green LED)	Lit if connection exists to Ethernet.
AUTOCAL (yellow LED)	Lit while AUTOCAL process is executing.
OUTPUT (green LED)	Indicates pulses in measurement mode. In control mode, luminous intensity is proportional to heating current.
HEAT (yellow LED)	Lit during heating phase.
ALARM (red LED)	Lit or blinking to indicate fault.
NETWORK STATUS (red/green)	Lit (green) if connection exists to EtherNet/IP scanner; lit (red) to indicate network error.
MODULE STATUS (red/green)	Lit (green) if there are no communication errors.
µC POWER (green LED)	Lit if internal power supply for EtherNet/IP interface is OK.
24V POWER (green LED)	Lit if external 24VDC power supply is present.

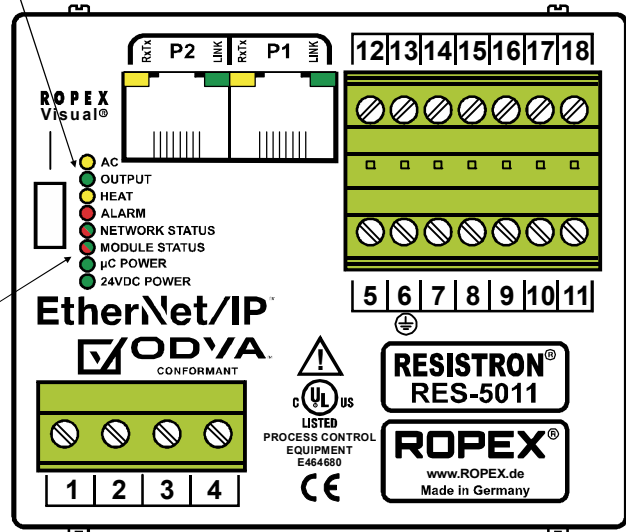

In addition to the functions shown above, the LEDs also indicate various controller operating states. These states are described in detail in the table below:

LED	Blinks slowly (1 Hz)	Blinks fast (4 Hz)	Lit continuously
AUTOCAL (yellow)	RS bit set (reset)	AUTOCAL requested but function blocked (e.g. START active)	AUTOCAL executing
	LED blinks at a different frequency: Supply voltages incorrect (too low)		

LED	Blinks slowly (1 Hz)	Blinks fast (4 Hz)	Lit continuously
HEAT (yellow)	—	START requested but function blocked (e.g. AUTOCAL active, set temperature < 40 °C)	START executing
OUTPUT (green)	In control mode, luminous intensity is proportional to heating current.		
ALARM (red)	Configuration error, no AUTOCAL possible	Controller calibrated incorrectly, run AUTOCAL	Error, ↪ section 8.19
MODULE STATUS	Green: Standby Red: Warning, e.g. rotary coding switch setting changed	Red / green: Self-test	Green: Normal operation Red: Serious communication error
NETWORK STATUS	Green: No connection but IP address received Red: Connection timeout	Red / green: Self-test	Green: At least one connection to scanner Red: IP address of controller already assigned
LINK PORT 1, 2 (green)	—	—	Connection exists to Ethernet
RX / TX PORT 1, 2 (yellow)	Device is transmitting / receiving Ethernet frames		

8.2 EtherNet/IP™ communication

The following sections only describe controller-specific functions. For general information on the EtherNet/IP™ interface and the system configuration, please refer to the description of your PLC.

The controller can communicate via the EtherNet/IP™ interface provided the 24 VDC supply voltage (terminals 5+7) is present.

If no line voltage is present however (e.g. if it is switched off in order to open a door), error code 901 or 201 (error group 7, no line voltage / sync signal) appears on the controller and the alarm relay is switched. This happens due to the absence of line voltage. The error message can be reset by switching on the line voltage again and setting the RS bit (☞ section 8.5.3 "Reset (RS)" on page 24).

You can easily process the error code that appears if the line voltage is switched off – or suppress switching of the alarm relay – in the PLC program.

8.3 Device description file (EDS)

The configuring tools for the EtherNet/IP™ scanner interpret the content of the device description files (EDS) and use this information to create a parameter set for the EtherNet/IP™ scanner which controls user data traffic. The ROPEX_RES-5011_V2_4.eds file of the RES-5011 contains all essential controller information for the configuration, e.g. the I/O data description, parameter descriptions etc. The device description files and the associated image files (.BMP and .ICO) can be requested by e-mail (support@ropex.de) or downloaded from our website (<https://ropex.de>).

If the controller already has an IP address, the device description file can also be downloaded from the integrated web server. Alternatively, you can download it from the controller via the file object using CIP services.

After linking the required device description file into the configuring tool, you must assign an IP address to the controller. DHCP is activated by default to enable the controller to request an IP address from a DHCP server in the network. You must also select the desired parameter values.

8.4 Communication protocol

The communication protocol consists of 2x16 bit input words and 3x16 bit output words (from the point of view of the controller). This protocol separates the set point and the actual value of the RES-5011 from the status information and the control functions, to simplify decoding by the EtherNet/IP™ scanner.

Bits 0...7 form the low byte and bits 8...15 the high byte ("INTEL format").

The 2 x 16-bit **input data** contains the set point in word ① and the control functions in word ②:

①	Spare							Set point / AC temperature									
Name:	0	0	0	0	0	0	0										
Bit no.:	15	14	13	12	11	10	9	8	7	6	5	4	3	2	1	0	

②	Spare					Channel			Spare			Control function				
Name:	0	0	0	0	0	CH2	CH1	CH0	0	0	0	MA	MP	RS	ST	AC
Bit no.:	15	14	13	12	11	10	9	8	7	6	5	4	3	2	1	0

The 3 x 16-bit **output data** contains the actual value in word ①, the status information in word ②, and the error code in word ③:

①	Actual value (signed)															
Name:																
Bit no.:	15	14	13	12	11	10	9	8	7	6	5	4	3	2	1	0

②	Spare				Channel			Status information								
Name:	0	0	0	MU ¹	CH2	CH1	CH0	SA	IA	WA	AA	AG	AL	TE	TO	RA
Bit no.:	15	14	13	12	11	10	9	8	7	6	5	4	3	2	1	0

1. As from firmware version 303

③	Error code															
Name:	0	0	0	0	0	0	A9	A8	A7	A6	A5	A4	A3	A2	A1	A0
Bit no.:	15	14	13	12	11	10	9	8	7	6	5	4	3	2	1	0

8.5 Input data

The term "input data" refers to the data that is transferred from the EtherNet/IP™ scanner to the RES-5011. It contains the set point as well as the control functions such as START or AUTOCAL for the RES-5011. These functions are explained in the following.

8.5.1 Automatic zero calibration AUTOCAL (AC)

Owing to the automatic zero calibration (AUTOCAL) function, there is no need to adjust the zero point manually on the controller. This function adjusts the controller to the current and voltage signals present in the system and calibrates it to the value which is predefined in the parameter data (↪ section 8.7.4 "Variable calibration temperature" on page 49). If no parameter data is transferred by the EtherNet/IP™ scanner, the default value is 20 °C.

Some EtherNet/IP™ scanners do not allow the parameter data to be changed during operation. In this case, the calibration temperature cannot be adapted to the actual ambient conditions in the machines.

The calibration temperature can thus be specified by means of the "Set point / AC temperature" input data whenever the zero point is calibrated, provided this is permitted in the parameter data (↪ section 8.7.4 "Variable calibration temperature" on page 49). You can specify it in the 0...+40 °C range. The specified calibration temperature must be entered in the "Set point / AC temperature" input data when the AUTOCAL function is activated (AC bit = 1). This specified value must not be changed until the AUTOCAL function has finished.

If the specified temperature is too high (greater than 40 °C) or if the specified value fluctuates, an error message appears (error codes 115 and 116; ↪ section 8.19 "Error messages" on page 63).

The AUTOCAL request (AC bit = 1) is executed by the controller provided the AUTOCAL function is not blocked. The automatic calibration takes around 10...15 seconds. The heatsealing band is not heated during this process. The yellow LED on the front panel lights up while the AUTOCAL function is executing and the controller shows "AUTOCAL active" (AA bit = 1) in the output data. The actual value output (terminals 17+18) changes to 0...3 °C (corresponds to approx. 0 VDC).

If the temperature of the heatsealing band fluctuates, the AUTOCAL function is executed a maximum of three times. If the function still cannot be executed successfully, an error message appears (↪ section 8.19 "Error messages" on page 63).

The AUTOCAL function should only be activated while the heatsealing band (and the environment, i.e. silicone, PTFE cover, sealing bar etc.) is still cold (base temperature).

Reasons for blocked AUTOCAL function:

1. An AUTOCAL request cannot be accepted until 10 seconds after the controller is switched on. During this time the controller shows "AUTOCAL blocked" (AG bit = 1) in the output data.
2. The AUTOCAL function is not activated if the heatsealing band cools down at a rate of more than 0.1 K/s. If the AC bit is set, the function is automatically executed when the cooling rate falls below the specified value.
3. If the START bit is set (ST bit = 1), the AUTOCAL function is not executed ("HEAT" LED lit).
4. If the RESET bit is set (RS bit = 1), the AUTOCAL function is not executed.
5. The AUTOCAL function cannot be activated if error codes 101...103, 201...203 or 9xx appear as soon as the controller is switched on (↪ section 8.19 "Error messages" on page 63). It also cannot be activated if error codes 201...203 or 9xx appear and the controller has operated correctly at least once since being switched on.

If the AUTOCAL function is blocked (AG bit = 1), an AUTOCAL request (AC bit = 1) causes the "AUTOCAL" LED to blink fast (4 Hz).

8.5.2 Start (ST)

When the START bit is set (ST bit = 1), the controller's internal set / actual comparison is enabled and the heatsealing band is heated to the SET temperature. It remains at this temperature either until the ST bit is reset or until the actual heating time exceeds the preset heating time limit (↪ section 8.7.5 "Heating time limit" on page 50).

The "HEAT" LED on the front panel of the RES-5011 lights up continuously for the duration of the heating time. A start request is not processed as long as the AUTOCAL function is active, a fault is present on the controller, the set point is less than 20 °C higher than the calibration temperature, or the RS bit is set. In this case, the "HEAT" LED blinks.

The heatup process is terminated if the ST bit is reset or if a communication error occurs.

The ST bit is only accepted if the AUTOCAL function is deactivated and there are no faults.

The alarm relay is switched if the ST bit is set while a warning with error code 104...106, 111...114, 211, 302, or 303 is indicated (↪ section 8.19 "Error messages" on page 63). The heating element is not heated.

8.5.3 Reset (RS)

This bit resets the controller if the controller shows a fault.

No AUTOCAL or START requests are accepted as long as the RS bit is set. Until it is reset again, only error codes 201...203, 901, 913 are evaluated and output by the error diagnosis function. The power unit is not activated in

this state and no measuring impulses are generated. As a result of this, the actual value is no longer updated. The reset request is not accepted until the RS bit is reset. EtherNet/IP™ communications are not interrupted by a controller reset.

The controller actual value output changes to 0...3 °C (i.e. approximately 0 VDC) and the SA bit is set in order to set the RS bit.

The AUTOCAL function is not canceled if the RS bit is set while it is executing.

The controller performs an internal initialization lasting approximately 500 ms after the RS bit is reset. The next heatsealing process cannot be started until it has finished.

If a Kb contactor is used to deactivate the control loop (↪ section 6.3 "Power supply" on page 10), it must be reliably energized again 200 ms at the latest after the RS bit is reset (note the contactor switching and delay times). If it is energized too late, an error message appears on the controller.

8.5.4 Measurement pause (MP)

No more measuring impulses are generated by the controller as soon as the MP bit is set. Until it is reset again, only error codes 5 and 7 (201...203, 901, 913) are evaluated and output by the error diagnosis function. In addition, the actual value is no longer updated. The last valid value before the MP bit was set is output. As soon as the MP bit is reset, new measuring impulses are generated, all error messages are evaluated, and the actual value is updated again.

The MP bit is only active in measurement mode. The bits ST, RS, and AC take priority.

The bit is suitable for all applications in which the electrical connections of the heatsealing band must be disconnected during normal operation without triggering a fault (e.g. sliding rail contacts).

Unlike the RS bit (RESET), the MP bit does not reset any faults when it is set. The controller is active again as soon as the MP bit is reset, in other words there is no initialization phase.

When the controller is switched on, it does not evaluate the MP bit until the system test (including the functional test of the heating circuit) has been successfully completed. This can take several hundred milliseconds.

8.5.5 Master AUTOCAL (MA)

Setting this control bit starts a calibration as described in section 8.5.1 "Automatic zero calibration AUTOCAL (AC)" on page 23. However, if the Master AUTOCAL function is successful, the heatsealing band resistance which is determined by the controller is also used as a reference value, e.g. after replacing the heatsealing band.

This reference value serves to calculate the deviation from the calibration value for all subsequent calibrations (initiated with the AC bit). This deviation helps you assess aging of the heatsealing band.

The deviation from the calibration value is queried by means of the parameter object.

8.5.6 Channel selection (CH0...CH2)

The temperature controller has separate memories for up to eight calibration data records. A calibration data record contains the values determined by the temperature controller during the AUTOCAL function. By storing the calibration data records, you can alternate between different sealing tools without having to run the AUTOCAL function every time the tool is changed. You only need to execute AUTOCAL if you connect a new heatsealing band.

Since different calibration values, AUTOCAL temperatures, and temperature coefficients are stored in the controller for this purpose, the required calibration data record 0...7 can be selected with the three bits CH0...CH2. You can switch to another channel at any time.

This function is useful, for instance, in applications where frequent changes of format are necessary. The tools can then be changed as required in order to handle the different formats. A channel containing the relevant calibration data record is assigned to each tool. Once all tools have been calibrated with a unique channel assignment, they can be changed at any time simply by selecting the appropriate channel.

If the application does not require any format changes, the channel can remain set to 0. In this case, the temperature controller behaves in exactly the same way as older models where different calibration data records are not supported.

It is possible to switch to another channel during the AUTOCAL function; however, the controller continues working with the original channel until the AUTOCAL function has finished. The channel currently being used by the controller is shown in the status information.

8.5.7 Set point

A set point of up to 300 °C or 500 °C is allowed, depending on the selected temperature range (↪ section 8.7.1 "Temperature range and alloy" on page 49). If you attempt to enter a higher set point, it is limited internally to 300 °C or 500 °C.

8.6 Output data

The term "output data" refers to the data that is transferred from the RES-5011 to the EtherNet/IP™ scanner. It contains the current actual value as well as all important information on the current status of the controller. If a fault is signaled, it can be diagnosed accurately with the help of the error code.

8.6.1 AUTOCAL active (AA)

The AA bit indicates that the AUTOCAL or AUTOCOMP function is executing.

8.6.2 AUTOCAL blocked (AG)

If the AG bit is set, the AUTOCAL function is temporarily blocked. This is the case if "START" is active or the heat-sealing band is still in the cooling phase.

8.6.3 Alarm active (AL)

If the AL bit is set, an alarm has been triggered but not yet reset. The error code provides information on the exact cause (↪ section 8.19 "Error messages" on page 63).

8.6.4 Warning active (WA)

This bit can be set in addition to the AL bit. If the WA bit is set, a warning is output to indicate the current fault. In this case, the alarm relay is not active.

8.6.5 Temperature achieved (TE)

The TE bit is set if the actual temperature exceeds 95% of the set temperature. This status bit is reset again as soon as you exit control mode (ST bit = 0) or a fault is signaled (AL bit = 1).

8.6.6 Temperature OK (TO)

The RES-5011 checks whether the actual temperature is within a settable tolerance band ("OK" window) either side of the set temperature. The high ($\Delta\vartheta_{high}$) and low ($\Delta\vartheta_{low}$) limits of the tolerance band can be changed independently of one another in the parameter data (↪ section 8.7 "Parameter object (class: 0x0F)" on page 28). The following settings are possible:

1. "Off"

The TO bit is always reset.

2. "Active when Tact = Tset" (factory setting)

The TO bit is set if the actual value is inside the specified temperature tolerance band. If the actual temperature is outside of the tolerance band, the TO bit is reset (see graph below).

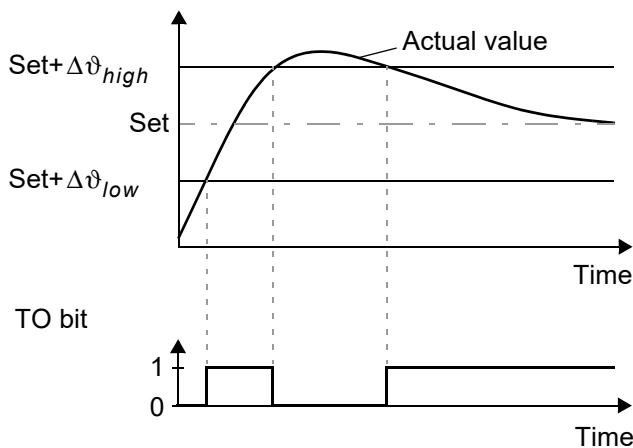

Unlike the "Temperature achieved" status bit (TE bit), the actual temperature is evaluated independently of the control mode.

3. "Active when Tact = Tset" with latch function

A heatsealing cycle starts when the ST bit is set. The TO bit is set when the actual temperature reaches the temperature tolerance band for the first time during a heatsealing cycle. If the actual temperature leaves the tolerance band again while the ST bit is still set, the TO bit is reset (Fig. a.). If the actual temperature does not leave the tolerance band while the ST bit is still set, the TO bit is not reset until the start of the next heatsealing cycle (latch function, Fig. b.). The switching state of the TO bit can thus be queried after the ST bit has been reset and before the start of the next heatsealing cycle.

a.) Temperature *not* ok

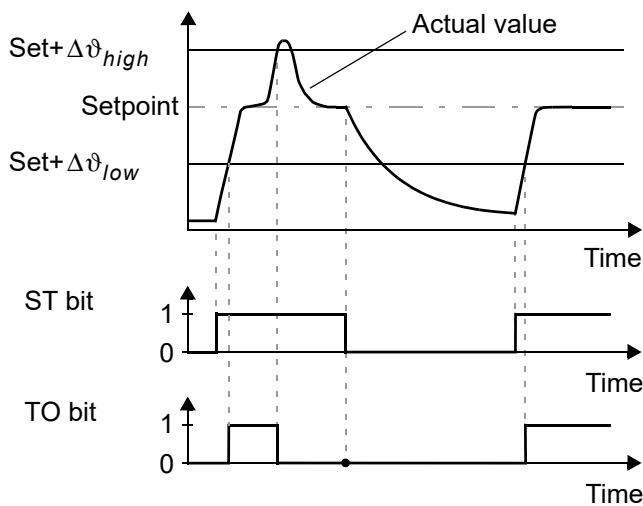

b.) Temperature ok

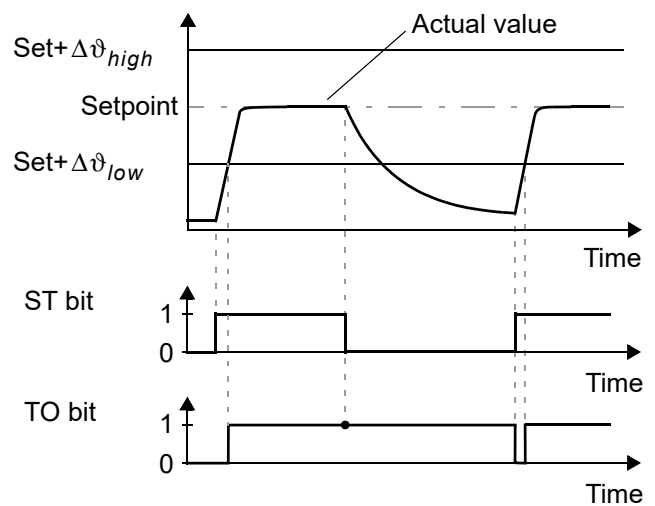

The limits of the tolerance band are adjustable up to a maximum of ± 99 K.

8.6.7 Control active (RA)

The RES-5011 has successfully accepted the "START" request and entered control mode if the RA bit = 1.

8.6.8 Info active (IA)

This bit is reserved for future use and is not currently supported (it is always set to 0).

8.6.9 Standby active (SA)

This bit is active if the RS bit is set. It shows the PLC when the controller has accepted the RS bit or the MP bit, so that these bits can be reset again (handshake).

8.6.10 Measurement interruption (MU)



This bit is available as from firmware version 303.

This bit is active as long as the controller does not perform a temperature measurement during the regulation phase (ST = 1). This can occur when the actual value is larger than the setpoint value (setpoint exceeded). This can be used, for example, to evaluate whether measurement interruptions occur during the heating impulse. This would then be an indication of excessive temperature, which can result in a bad sealing seam.

As soon as a measurement is performed again, the MU bit goes back to 0.

8.6.11 Actual value

All 16 bits of the first word must be interpreted as a signed number (twos complement notation). The resolution is 1 °C. During the calibration procedure or if a fault occurs, the actual value is 0.

8.6.12 Error codes

If a fault is signaled (AL bit = 1), you can determine the exact cause with the help of the error code. The error code is contained in the third word at bit positions 0...9 (↪ section 8.19 "Error messages" on page 63).

8.7 Parameter object (class: 0x0F)

In accordance with the CIP specification, the RES-5011 provides a parameter object containing all of the device parameters.

All instances of the parameter object support the "Get_Attribute_Single" and "Get_Attribute_All" services. The class (instance 0) additionally supports the "Save", "Restore", and "Reset" services. The instances additionally support the "Set_Attribute_Single" service for attribute 1.



The instances 54 to 70 are first available as from firmware 303.

The parameter object has the following structure:

Instance	Attribute ID	Data type ¹	Name	Default value	Value range
0 (class)	1	UINT	Revision	1	
	2	UINT	Max. instance	70	
	6	UINT	Max. class attribute	9	
	7	UINT	Max. instance attribute	6	
	8	UINT	Parameter class description	13	
	9	UINT	Configuration assembly	102	

Instance	Attribute ID	Data type ¹	Name	Default value	Value range
1	1	USINT	Temperature range / alloy	10	0, 1, 4, 5, 8, 9, 10, 11 (↪ 8.7.1)
	2	USINT	Link path length	6	
	3	EPATH	Link path	20 0F 24 01 30 01	
	4	WORD	Descriptor	0x0000	
	5	USINT	Data type	0xC6	
	6	USINT	Data length	1	
2	1	USINT	Low temperature OK threshold	10 K	3...99 K
	2	USINT	Link path length	6	
	3	EPATH	Link path	20 0F 24 02 30 01	
	4	WORD	Descriptor	0x0000	
	5	USINT	Data type	0xC6	
	6	USINT	Data length	1	
3	1	USINT	High temperature OK threshold	10 K	3...99 K
	2	USINT	Link path length	6	
	3	EPATH	Link path	20 0F 24 03 30 01	
	4	WORD	Descriptor	0x0000	
	5	USINT	Data type	0xC6	
	6	USINT	Data length	1	
4	1	SINT	Calibration temperature	20 °C	-1 (= variable), 0...40 °C
	2	USINT	Link path length	6	
	3	EPATH	Link path	20 0F 24 04 30 01	
	4	WORD	Descriptor	0x0000	
	5	USINT	Data type	0xC2	
	6	USINT	Data length	1	

Instance	Attribute ID	Data type ¹	Name	Default value	Value range
5	1	UINT	Heating time limit (100 ms steps)	0	0...999 (0...99.9 s)
	2	USINT	Link path length	6	
	3	EPATH	Link path	20 0F 24 05 30 01	
	4	WORD	Descriptor	0x0004 (scaling supported)	
	5	USINT	Data type	0xC7	
	6	USINT	Data length	2	
	13	USINT	Factor	1	
	14	USINT	Divisor	10	
	15	USINT	Base	1	
6	1	USINT	Measuring impulse duration	1.7 ms (17)	1.7...3.0 ms (17...30)
	2	USINT	Link path length	6	
	3	EPATH	Link path	20 0F 24 06 30 01	
	4	WORD	Descriptor	0x0004 (scaling supported)	
	5	USINT	Data type	0xC6	
	6	USINT	Data length	1	
	13	USINT	Factor	1	
	14	USINT	Divisor	10	
	15	USINT	Base	1	
7	1	BOOL	Data format	Little Endian, Intel (0)	Little Endian, Intel (0), Big Endian, Motorola (1)
	2	USINT	Link path length	6	
	3	EPATH	Link path	20 0F 24 07 30 01	
	4	WORD	Descriptor	0x0000	
	5	USINT	Data type	0xC6	
	6	USINT	Data length	1	

Instance	Attribute ID	Data type ¹	Name	Default value	Value range
8	1	UINT	Temperature coefficient	1100 ppm/K	400...4000 ppm/K
	2	USINT	Link path length	6	
	3	EPATH	Link path	20 0F 24 08 30 01	
	4	WORD	Descriptor	0x0000	
	5	USINT	Data type	0xC7	
	6	USINT	Data length	2	
9	1	USINT	Temperature range	1 (300 °C)	200 °C (0), 300 °C (1), 400 °C (2), 500 °C (3)
	2	USINT	Link path length	6	
	3	EPATH	Link path	20 0F 24 09 30 01	
	4	WORD	Descriptor	0x0000	
	5	USINT	Data type	0xC6	
	6	USINT	Data length	1	
10	1	UINT	Maximum temperature	300 °C	200...500 °C
	2	USINT	Link path length	6	
	3	EPATH	Link path	20 0F 24 0A 30 01	
	4	WORD	Descriptor	0x0000	
	5	USINT	Data type	0xC7	
	6	USINT	Data length	2	
11	1	BOOL	Temperature diagnosis	Off (0)	Off (0), on (1)
	2	USINT	Link path length	6	
	3	EPATH	Link path	20 0F 24 0B 30 01	
	4	WORD	Descriptor	0x0000	
	5	USINT	Data type	0xC1	
	6	USINT	Data length	1	

Instance	Attribute ID	Data type ¹	Name	Default value	Value range
12	1	USINT	Temperature diagnosis delay (100 ms steps)	0 s	0...99 (0...9.9 s)
	2	USINT	Link path length	6	
	3	EPATH	Link path	20 0F 24 0C 30 01	
	4	WORD	Descriptor	0x0004 (scaling supported)	
	5	USINT	Data type	0xC6	
	6	USINT	Data length	1	
	13	USINT	Factor	1	
	14	USINT	Divisor	10	
	15	USINT	Base	1	
16	USINT	Offset	0		
13	1	UINT	Heatup timeout (100 ms steps)	0 s	0...999 (0...99.9 s)
	2	USINT	Link path length	6	
	3	EPATH	Link path	20 0F 24 0D 30 01	
	4	WORD	Descriptor	0x0004 (scaling supported)	
	5	USINT	Data type	0xC7	
	6	USINT	Data length	2	
	13	USINT	Factor	1	
	14	USINT	Divisor	10	
	15	USINT	Base	1	
16	USINT	Offset	0		
14	1	USINT	AUTOCOMP	Off	Off (0), on (1), auto (2)
	2	USINT	Link path length	6	
	3	EPATH	Link path	20 0F 24 0E 30 01	
	4	WORD	Descriptor	0x0000	
	5	USINT	Data type	0xC6	
	6	USINT	Data length	1	

Instance	Attribute ID	Data type ¹	Name	Default value	Value range
15	1	USINT	Temperature OK bit	Active when Tact=Tset	Off (0), active when Tact=Tset (1), active when Tact=Tset with latch (2)
	2	USINT	Link path length	6	
	3	EPATH	Link path	20 0F 24 0F 30 01	
	4	WORD	Descriptor	0x0000	
	5	USINT	Data type	0xC6	
	6	USINT	Data length	1	
16	1	USINT	Hold mode	Off	Off (0), on (1), 2 s (2)
	2	USINT	Link path length	6	
	3	EPATH	Link path	20 0F 24 10 30 01	
	4	WORD	Descriptor	0x0000	
	5	USINT	Data type	0xC6	
	6	USINT	Data length	1	
17	1	SINT	Calibration temperature, channel 1	20 °C	-1 (= variable), 0...40 °C
	2	USINT	Link path length	6	
	3	EPATH	Link path	20 0F 24 11 30 01	
	4	WORD	Descriptor	0x0000	
	5	USINT	Data type	0xC2	
	6	USINT	Data length	1	
18	1	UINT	Temperature coefficient, channel 1	1100 ppm/K	400...4000 ppm/K
	2	USINT	Link path length	6	
	3	EPATH	Link path	20 0F 24 12 30 01	
	4	WORD	Descriptor	0x0000	
	5	USINT	Data type	0xC7	
	6	USINT	Data length	2	

Instance	Attribute ID	Data type ¹	Name	Default value	Value range
19	1	SINT	Calibration temperature, channel 2	20 °C	-1 (= variable), 0...40 °C
	2	USINT	Link path length	6	
	3	EPATH	Link path	20 0F 24 12 30 01	
	4	WORD	Descriptor	0x0000	
	5	USINT	Data type	0xC2	
	6	USINT	Data length	1	
20	1	UINT	Temperature coefficient, channel 2	1100 ppm/K	400...4000 ppm/K
	2	USINT	Link path length	6	
	3	EPATH	Link path	20 0F 24 13 30 01	
	4	WORD	Descriptor	0x0000	
	5	USINT	Data type	0xC7	
	6	USINT	Data length	2	
21	1	SINT	Calibration temperature, channel 3	20 °C	-1 (= variable), 0...40 °C
	2	USINT	Link path length	6	
	3	EPATH	Link path	20 0F 24 14 30 01	
	4	WORD	Descriptor	0x0000	
	5	USINT	Data type	0xC2	
	6	USINT	Data length	1	
22	1	UINT	Temperature coefficient, channel 3	1100 ppm/K	400...4000 ppm/K
	2	USINT	Link path length	6	
	3	EPATH	Link path	20 0F 24 15 30 01	
	4	WORD	Descriptor	0x0000	
	5	USINT	Data type	0xC7	
	6	USINT	Data length	2	
23	1	SINT	Calibration temperature, channel 4	20 °C	-1 (= variable), 0...40 °C
	2	USINT	Link path length	6	
	3	EPATH	Link path	20 0F 24 16 30 01	
	4	WORD	Descriptor	0x0000	
	5	USINT	Data type	0xC2	
	6	USINT	Data length	1	

Instance	Attribute ID	Data type ¹	Name	Default value	Value range
24	1	UINT	Temperature coefficient, channel 4	1100 ppm/K	400...4000 ppm/K
	2	USINT	Link path length	6	
	3	EPATH	Link path	20 0F 24 17 30 01	
	4	WORD	Descriptor	0x0000	
	5	USINT	Data type	0xC7	
	6	USINT	Data length	2	
25	1	SINT	Calibration temperature, channel 5	20 °C	-1 (= variable), 0...40 °C
	2	USINT	Link path length	6	
	3	EPATH	Link path	20 0F 24 18 30 01	
	4	WORD	Descriptor	0x0000	
	5	USINT	Data type	0xC2	
	6	USINT	Data length	1	
26	1	UINT	Temperature coefficient, channel 5	1100 ppm/K	400...4000 ppm/K
	2	USINT	Link path length	6	
	3	EPATH	Link path	20 0F 24 1A 30 01	
	4	WORD	Descriptor	0x0000	
	5	USINT	Data type	0xC7	
	6	USINT	Data length	2	
27	1	SINT	Calibration temperature, channel 6	20 °C	-1 (= variable), 0...40 °C
	2	USINT	Link path length	6	
	3	EPATH	Link path	20 0F 24 1B 30 01	
	4	WORD	Descriptor	0x0000	
	5	USINT	Data type	0xC2	
	6	USINT	Data length	1	
28	1	UINT	Temperature coefficient, channel 6	1100 ppm/K	400...4000 ppm/K
	2	USINT	Link path length	6	
	3	EPATH	Link path	20 0F 24 1C 30 01	
	4	WORD	Descriptor	0x0000	
	5	USINT	Data type	0xC7	
	6	USINT	Data length	2	

Instance	Attribute ID	Data type ¹	Name	Default value	Value range
29	1	SINT	Calibration temperature, channel 7	20 °C	-1 (= variable), 0...40 °C
	2	USINT	Link path length	6	
	3	EPATH	Link path	20 0F 24 1D 30 01	
	4	WORD	Descriptor	0x0000	
	5	USINT	Data type	0xC2	
	6	USINT	Data length	1	
30	1	UINT	Temperature coefficient, channel 7	1100 ppm/K	400...4000 ppm/K
	2	USINT	Link path length	6	
	3	EPATH	Link path	20 0F 24 1E 30 01	
	4	WORD	Descriptor	0x0000	
	5	USINT	Data type	0xC7	
	6	USINT	Data length	2	
31	1	DATE	Date (days since 1972-01-01)	01.01.2000	
	2	USINT	Link path length	6	
	3	EPATH	Link path	20 0F 24 1F 30 01	
	4	WORD	Descriptor	0x0000	
	5	USINT	Data type	0xCD	
	6	USINT	Data length	2	
32	1	TIME_OF_DAY	Time (milliseconds since 00:00)	00:00:00:00	
	2	USINT	Link path length	6	
	3	EPATH	Link path	20 0F 24 20 30 01	
	4	WORD	Descriptor	0x0000	
	5	USINT	Data type	0xCE	
	6	USINT	Data length	4	

Instance	Attribute ID	Data type ¹	Name	Default value	Value range
33	1	UDINT	Operating hours	0	0...99999999.9 h
	2	USINT	Link path length	6	
	3	EPATH	Link path	20 0F 24 21 30 01	
	4	WORD	Descriptor	0x0014 (scaling supported)	
	5	USINT	Data type	0xC8	
	6	USINT	Data length	4	
	13	USINT	Factor	1	
	14	USINT	Divisor	10	
	15	USINT	Base	1	
	16	USINT	Offset	0	
34	1	UDINT	Cycle counter (non-clearable)	0	0...99999999
	2	USINT	Link path length	6	
	3	EPATH	Link path	20 0F 24 22 30 01	
	4	WORD	Descriptor	0x0010	
	5	USINT	Data type	0xC8	
	6	USINT	Data length	4	
35	1	UDINT	Cycle counter (clearable)	0	0...99999999
	2	USINT	Link path length	6	
	3	EPATH	Link path	20 0F 24 23 30 01	
	4	WORD	Descriptor	0x0000	
	5	USINT	Data type	0xC8	
	6	USINT	Data length	4	
36	1	UDINT	Cycle counter, channel 0	0	0...99999999
	2	USINT	Link path length	6	
	3	EPATH	Link path	20 0F 24 24 30 01	
	4	WORD	Descriptor	0x0000	
	5	USINT	Data type	0xC8	
	6	USINT	Data length	4	

Instance	Attribute ID	Data type ¹	Name	Default value	Value range
37	1	UDINT	Cycle counter, channel 1	0	0...999999999
	2	USINT	Link path length	6	
	3	EPATH	Link path	20 0F 24 25 30 01	
	4	WORD	Descriptor	0x0000	
	5	USINT	Data type	0xC8	
	6	USINT	Data length	4	
38	1	UDINT	Cycle counter, channel 2	0	0...999999999
	2	USINT	Link path length	6	
	3	EPATH	Link path	20 0F 24 26 30 01	
	4	WORD	Descriptor	0x0000	
	5	USINT	Data type	0xC8	
	6	USINT	Data length	4	
39	1	UDINT	Cycle counter, channel 3	0	0...999999999
	2	USINT	Link path length	6	
	3	EPATH	Link path	20 0F 24 27 30 01	
	4	WORD	Descriptor	0x0000	
	5	USINT	Data type	0xC8	
	6	USINT	Data length	4	
40	1	UDINT	Cycle counter, channel 4	0	0...999999999
	2	USINT	Link path length	6	
	3	EPATH	Link path	20 0F 24 28 30 01	
	4	WORD	Descriptor	0x0000	
	5	USINT	Data type	0xC8	
	6	USINT	Data length	4	
41	1	UDINT	Cycle counter, channel 5	0	0...999999999
	2	USINT	Link path length	6	
	3	EPATH	Link path	20 0F 24 29 30 01	
	4	WORD	Descriptor	0x0000	
	5	USINT	Data type	0xC8	
	6	USINT	Data length	4	

Instance	Attribute ID	Data type ¹	Name	Default value	Value range
42	1	UDINT	Cycle counter, channel 6	0	0...999999999
	2	USINT	Link path length	6	
	3	EPATH	Link path	20 0F 24 2A 30 01	
	4	WORD	Descriptor	0x0000	
	5	USINT	Data type	0xC8	
	6	USINT	Data length	4	
43	1	UDINT	Cycle counter, channel 7	0	0...999999999
	2	USINT	Link path length	6	
	3	EPATH	Link path	20 0F 24 2B 30 01	
	4	WORD	Descriptor	0x0000	
	5	USINT	Data type	0xC8	
	6	USINT	Data length	4	
44	1	INT	Start temperature	-99	-99...999 °C
	2	USINT	Link path length	6	
	3	EPATH	Link path	20 0F 24 2C 30 01	
	4	WORD	Descriptor	0x0010	
	5	USINT	Data type	0xC3	
	6	USINT	Data length	2	
45	1	INT	Device temperature		-99...99 °C
	2	USINT	Link path length	6	
	3	EPATH	Link path	20 0F 24 2D 30 01	
	4	WORD	Descriptor	0x0010	
	5	USINT	Data type	0xC3	
	6	USINT	Data length	2	

Instance	Attribute ID	Data type ¹	Name	Default value	Value range
46	1	INT	Calibration deviation, channel 0	0	-100.00...100.00%
	2	USINT	Link path length	6	
	3	EPATH	Link path	20 0F 24 2E 30 01	
	4	WORD	Descriptor	0x0014 (scaling supported)	
	5	USINT	Data type	0xC3	
	13	USINT	Factor	1	
	14	USINT	Divisor	100	
	15	USINT	Basis	1	
	16	USINT	Offset	0	
47	1	INT	Calibration deviation, channel 1	0	-100.00...100.00%
	2	USINT	Link path length	6	
	3	EPATH	Link path	20 0F 24 2F 30 01	
	4	WORD	Descriptor	0x0014 (scaling supported)	
	5	USINT	Data type	0xC3	
	6	USINT	Data length	2	
	13	USINT	Factor	1	
	14	USINT	Divisor	100	
	15	USINT	Basis	1	
	16	USINT	Offset	0	
48	1	INT	Calibration deviation, channel 2	0	-100.00...100.00%
	2	USINT	Link path length	6	
	3	EPATH	Link path	20 0F 24 30 30 01	
	4	WORD	Descriptor	0x0014 (scaling supported)	
	5	USINT	Data type	0xC3	
	6	USINT	Data length	2	
	13	USINT	Factor	1	
	14	USINT	Divisor	100	
	15	USINT	Basis	1	
	16	USINT	Offset	0	

Instance	Attribute ID	Data type ¹	Name	Default value	Value range
49	1	INT	Calibration deviation, channel 2	0	-100.00...100.00%
	2	USINT	Link path length	6	
	3	EPATH	Link path	20 0F 24 31 30 01	
	4	WORD	Descriptor	0x0014 (scaling supported)	
	5	USINT	Data type	0xC3	
	6	USINT	Data length	2	
	13	USINT	Factor	1	
	14	USINT	Divisor	100	
	15	USINT	Basis	1	
	16	USINT	Offset	0	
50	1	INT	Calibration deviation, channel 4	0	-100.00...100.00%
	2	USINT	Link path length	6	
	3	EPATH	Link path	20 0F 24 32 30 01	
	4	WORD	Descriptor	0x0014 (scaling supported)	
	5	USINT	Data type	0xC3	
	6	USINT	Data length	2	
	13	USINT	Factor	1	
	14	USINT	Divisor	100	
	15	USINT	Basis	1	
	16	USINT	Offset	0	
51	1	INT	Calibration deviation, channel 5	0	-100.00...100.00%
	2	USINT	Link path length	6	
	3	EPATH	Link path	20 0F 24 33 30 01	
	4	WORD	Descriptor	0x0014 (scaling supported)	
	5	USINT	Data type	0xC3	
	6	USINT	Data length	2	
	13	USINT	Factor	1	
	14	USINT	Divisor	100	
	15	USINT	Basis	1	
	16	USINT	Offset	0	

Instance	Attribute ID	Data type ¹	Name	Default value	Value range
52	1	INT	Calibration deviation, channel 6	0	-100.00...100.00%
	2	USINT	Link path length	6	
	3	EPATH	Link path	20 0F 24 34 30 01	
	4	WORD	Descriptor	0x0014 (scaling supported)	
	5	USINT	Data type	0xC3	
	6	USINT	Data length	2	
	13	USINT	Factor	1	
	14	USINT	Divisor	100	
	15	USINT	Basis	1	
16	USINT	Offset	0		
53	1	INT	Calibration deviation, channel 7	0	-100.00...100.00%
	2	USINT	Link path length	6	
	3	EPATH	Link path	20 0F 24 35 30 01	
	4	WORD	Descriptor	0x0014 (scaling supported)	
	5	USINT	Data type	0xC3	
	6	USINT	Data length	2	
	13	USINT	Factor	1	
	14	USINT	Divisor	100	
	15	USINT	Basis	1	
16	USINT	Offset	0		
54	1	USINT	Passes through current transformer	1	1...9
	2	USINT	Link path length	6	
	3	EPATH	Link path	20 0F 24 36 30 01	
	4	WORD	Descriptor	0x0000	
	5	USINT	Data type	0xC6	
	6	USINT	Data length	1	

Instance	Attribute ID	Data type ¹	Name	Default value	Value range
55	1	UINT	Calibration resistance, channel 0 (in 0.1 mΩ)	0 mΩ	0...65535 (0...6553.5 mΩ)
	2	USINT	Link path length	6	
	3	EPATH	Link path	20 0F 24 37 30 01	
	4	WORD	Descriptor	0x0014 (scaling supported)	
	5	USINT	Data type	0xC7	
	6	USINT	Data length	2	
	13	USINT	Factor	1	
	14	USINT	Divisor	10	
	15	USINT	Basis	1	
16	USINT	Offset	0		
56	1	UINT	Calibration resistance, channel 1 (in 0.1 mΩ)	0 mΩ	0...65535 (0...6553.5 mΩ)
	2	USINT	Link path length	6	
	3	EPATH	Link path	20 0F 24 38 30 01	
	4	WORD	Descriptor	0x0014 (scaling supported)	
	5	USINT	Data type	0xC7	
	6	USINT	Data length	2	
	13	USINT	Factor	1	
	14	USINT	Divisor	10	
	15	USINT	Basis	1	
16	USINT	Offset	0		
57	1	UINT	Calibration resistance, channel 2 (in 0.1 mΩ)	0 mΩ	0...65535 (0...6553.5 mΩ)
	2	USINT	Link path length	6	
	3	EPATH	Link path	20 0F 24 39 30 01	
	4	WORD	Descriptor	0x0014 (scaling supported)	
	5	USINT	Data type	0xC7	
	6	USINT	Data length	2	
	13	USINT	Factor	1	
	14	USINT	Divisor	10	
	15	USINT	Basis	1	
16	USINT	Offset	0		

Instance	Attribute ID	Data type ¹	Name	Default value	Value range
58	1	UINT	Calibration resistance, channel 3 (in 0.1 mΩ)	0 mΩ	0...65535 (0...6553.5 mΩ)
	2	USINT	Link path length	6	
	3	EPATH	Link path	20 0F 24 3A 30 01	
	4	WORD	Descriptor	0x0014 (scaling supported)	
	5	USINT	Data type	0xC7	
	6	USINT	Data length	2	
	13	USINT	Factor	1	
	14	USINT	Divisor	10	
	15	USINT	Basis	1	
16	USINT	Offset	0		
59	1	UINT	Calibration resistance, channel 4 (in 0.1 mΩ)	0 mΩ	0...65535 (0...6553.5 mΩ)
	2	USINT	Link path length	6	
	3	EPATH	Link path	20 0F 24 3B 30 01	
	4	WORD	Descriptor	0x0014 (scaling supported)	
	5	USINT	Data type	0xC7	
	6	USINT	Data length	2	
	13	USINT	Factor	1	
	14	USINT	Divisor	10	
	15	USINT	Basis	1	
16	USINT	Offset	0		
60	1	UINT	Calibration resistance, channel 5 (in 0.1 mΩ)	0 mΩ	0...65535 (0...6553.5 mΩ)
	2	USINT	Link path length	6	
	3	EPATH	Link path	20 0F 24 3C 30 01	
	4	WORD	Descriptor	0x0014 (scaling supported)	
	5	USINT	Data type	0xC7	
	6	USINT	Data length	2	
	13	USINT	Factor	1	
	14	USINT	Divisor	10	
	15	USINT	Basis	1	
16	USINT	Offset	0		

Instance	Attribute ID	Data type ¹	Name	Default value	Value range
61	1	UINT	Calibration resistance, channel 6 (in 0.1 mΩ)	0 mΩ	0...65535 (0...6553.5 mΩ)
	2	USINT	Link path length	6	
	3	EPATH	Link path	20 0F 24 3D 30 01	
	4	WORD	Descriptor	0x0014 (scaling supported)	
	5	USINT	Data type	0xC7	
	6	USINT	Data length	2	
	13	USINT	Factor	1	
	14	USINT	Divisor	10	
	15	USINT	Basis	1	
16	USINT	Offset	0		
62	1	UINT	Calibration resistance, channel 7 (in 0.1 mΩ)	0 mΩ	0...65535 (0...6553.5 mΩ)
	2	USINT	Link path length	6	
	3	EPATH	Link path	20 0F 24 3E 30 01	
	4	WORD	Descriptor	0x0014 (scaling supported)	
	5	USINT	Data type	0xC7	
	6	USINT	Data length	2	
	13	USINT	Factor	1	
	14	USINT	Divisor	10	
	15	USINT	Basis	1	
16	USINT	Offset	0		
63	1	UINT	Initial calibration resistance, channel 0 (in 0.1 mΩ)	0 mΩ	0...65535 (0...6553.5 mΩ)
	2	USINT	Link path length	6	
	3	EPATH	Link path	20 0F 24 3F 30 01	
	4	WORD	Descriptor	0x0014 (scaling supported)	
	5	USINT	Data type	0xC7	
	6	USINT	Data length	2	
	13	USINT	Factor	1	
	14	USINT	Divisor	10	
	15	USINT	Basis	1	
16	USINT	Offset	0		

Instance	Attribute ID	Data type ¹	Name	Default value	Value range
64	1	UINT	Initial calibration resistance, channel 1 (in 0.1 mΩ)	0 mΩ	0...65535 (0...6553.5 mΩ)
	2	USINT	Link path length	6	
	3	EPATH	Link path	20 0F 24 40 30 01	
	4	WORD	Descriptor	0x0014 (scaling supported)	
	5	USINT	Data type	0xC7	
	6	USINT	Data length	2	
	13	USINT	Factor	1	
	14	USINT	Divisor	10	
	15	USINT	Basis	1	
16	USINT	Offset	0		
65	1	UINT	Initial calibration resistance, channel 2 (in 0.1 mΩ)	0 mΩ	0...65535 (0...6553.5 mΩ)
	2	USINT	Link path length	6	
	3	EPATH	Link path	20 0F 24 41 30 01	
	4	WORD	Descriptor	0x0014 (scaling supported)	
	5	USINT	Data type	0xC7	
	6	USINT	Data length	2	
	13	USINT	Factor	1	
	14	USINT	Divisor	10	
	15	USINT	Basis	1	
16	USINT	Offset	0		
66	1	UINT	Initial calibration resistance, channel 3 (in 0.1 mΩ)	0 mΩ	0...65535 (0...6553.5 mΩ)
	2	USINT	Link path length	6	
	3	EPATH	Link path	20 0F 24 42 30 01	
	4	WORD	Descriptor	0x0014 (scaling supported)	
	5	USINT	Data type	0xC7	
	6	USINT	Data length	2	
	13	USINT	Factor	1	
	14	USINT	Divisor	10	
	15	USINT	Basis	1	
16	USINT	Offset	0		

Instance	Attribute ID	Data type ¹	Name	Default value	Value range
67	1	UINT	Initial calibration resistance, channel 4 (in 0.1 mΩ)	0 mΩ	0...65535 (0...6553.5 mΩ)
	2	USINT	Link path length	6	
	3	EPATH	Link path	20 0F 24 43 30 01	
	4	WORD	Descriptor	0x0014 (scaling supported)	
	5	USINT	Data type	0xC7	
	6	USINT	Data length	2	
	13	USINT	Factor	1	
	14	USINT	Divisor	10	
	15	USINT	Basis	1	
16	USINT	Offset	0		
68	1	UINT	Initial calibration resistance, channel 5 (in 0.1 mΩ)	0 mΩ	0...65535 (0...6553.5 mΩ)
	2	USINT	Link path length	6	
	3	EPATH	Link path	20 0F 24 44 30 01	
	4	WORD	Descriptor	0x0014 (scaling supported)	
	5	USINT	Data type	0xC7	
	6	USINT	Data length	2	
	13	USINT	Factor	1	
	14	USINT	Divisor	10	
	15	USINT	Basis	1	
16	USINT	Offset	0		
69	1	UINT	Initial calibration resistance, channel 6 (in 0.1 mΩ)	0 mΩ	0...65535 (0...6553.5 mΩ)
	2	USINT	Link path length	6	
	3	EPATH	Link path	20 0F 24 45 30 01	
	4	WORD	Descriptor	0x0014 (scaling supported)	
	5	USINT	Data type	0xC7	
	6	USINT	Data length	2	
	13	USINT	Factor	1	
	14	USINT	Divisor	10	
	15	USINT	Basis	1	
16	USINT	Offset	0		

Instance	Attribute ID	Data type ¹	Name	Default value	Value range
70	1	UINT	Initial calibration resistance, channel 7 (in 0.1 mΩ)	0 mΩ	0...65535 (0...6553.5 mΩ)
	2	USINT	Link path length	6	
	3	EPATH	Link path	20 0F 24 46 30 01	
	4	WORD	Descriptor	0x0014 (scaling supported)	
	5	USINT	Data type	0xC7	
	6	USINT	Data length	2	
	13	USINT	Factor	1	
	14	USINT	Divisor	10	
	15	USINT	Basis	1	
16	USINT	Offset	0		

1. USINT: Unsigned short integer (8-bit value, unsigned)
 SINT: Short integer (8-bit value, signed)
 UINT: Unsigned integer (16-bit value, unsigned)
 UDINT: Unsigned double integer (32-bit value, unsigned)
 BOOL: 1-bit value
 WORD: 16-bit value
 EPATH: CIP path segment

Changes to one or more instances are normally only temporary, i.e. they are undone again when the supply voltage is interrupted. All write protected instances with the descriptors 0x0010 are an exception (these cannot be changed); the same applies to the instances for the time (31), date (32), the clearable counters (35...43) and the passes through current transformer (54). Changes to these instances take effect immediately and are also effective the next time the device is switched on.



However, changes to other instances can be saved in a retentive memory area of the controller using the CIP "Save (0x16)" service, in which case the values are restored after the supply voltage is reconnected. The CIP "Restore (0x15)" service allows you to load stored values back from the retentive memory area to the temporary memory again at any time in order to undo unwanted changes.

The CIP "Reset (0x05)" service resets all instances of the parameter object to their default values. This applies to both temporary (volatile) and retentive objects.

The "Save", "Restore", and "Reset" services can only be applied to the class (instance 0). All attributes of the parameter object concerned are simultaneously saved or restored.

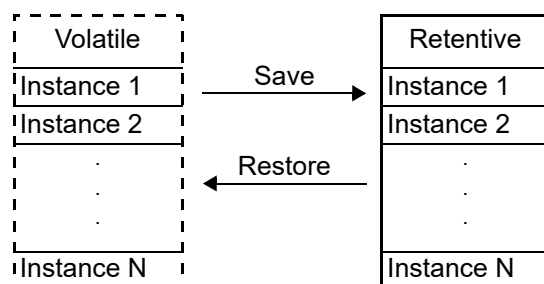
Parameter object



-  **When the controller is switched on, the last values saved in the retentive parameter object are automatically restored.**
-  **If the controller needs to be replaced, you must load the old parameter data into the new controller using a suitable network configuration tool and then run the "Save" service.**
-  **The parameter object is also reset to the default values if a type 1 reset is triggered on the identity object (class 1).**

8.7.1 Temperature range and alloy

This parameter determines both the temperature range and the heatsealing band alloy. You can overwrite the setting of the rotary coding switch (↪ section 7.2.2 "Configuration of the rotary coding switch for the temperature range and alloy" on page 16) by changing the default value (10).

Value	Temperature range	Alloy
0	300 °C	TCR = 1100 ppm/K, e.g. Alloy 20
1	300 °C	TCR = 780 ppm/K, e.g. Alloy L
4	500 °C	TCR = 1100 ppm/K, e.g. Alloy 20
5	500 °C	TCR = 780 ppm/K, e.g. Alloy L
8	300 °C	TCR = 3500 ppm/K, e.g. NOREX
9	PC setting (visualization software)	PC setting (visualization software)
10	Rotary coding switch setting	Rotary coding switch setting
11	Variable: Parameter instance 9 is used	Variable: Parameter instance 8 as well as the channel-specific temperature coefficients at instances 18, 20, 22, 24,26, 28 and 30 are used

You must always execute the AUTOCAL function after changing the "Temperature range / alloy", "Temperature range", or "Temperature coefficient" parameter.

8.7.2 Low temperature OK threshold

Low threshold value for the "OK" window.

Refer to section 8.6.6 "Temperature OK (TO)" on page 26 and section 8.7.9 "Temperature diagnosis" on page 52.

8.7.3 High temperature OK threshold

High threshold value for the "OK" window.

Refer to section 8.6.6 "Temperature OK (TO)" on page 26 and section 8.7.9 "Temperature diagnosis" on page 52.

8.7.4 Variable calibration temperature

The calibration temperature is set to 20 °C by default. You can change it to another value between 0 °C and 40 °C in order to adapt it to the temperature of the cold heatsealing band.

Some EtherNet/IP™ scanners do not allow the parameter data to be changed during operation. In this case, the calibration temperature cannot be adapted to the actual ambient conditions in the machines.

The calibration temperature can thus be enabled for setting by means of the input data by specifying the value "-1" in the parameter data. The calibration temperature can then be specified via the "Set point / AC temperature" input data (↪ section 8.5.1 "Automatic zero calibration AUTOCAL (AC)" on page 23).

After a change of the calibration temperature, the AUTOCAL function must be performed.

8.7.5 Heating time limit

The heating time limit provides additional protection against unwanted continuous heating. The controller automatically deactivates the heating impulse after the set heating time limit has elapsed if the ST bit remains set for longer than the time specified with this limit. The ST bit must be reset before the controller can be started up again. The heating time limit is deactivated by default (0) but can be set to any value between 0 s and 99.9 s (0 and 999).

8.7.6 Measuring impulse duration

The length of the measuring impulses generated by the controller can be set with this parameter. It may be necessary to set a measuring impulse longer than the default 1.7 ms for certain applications.

8.7.7 Data format

This parameter specifies the order of the bytes ("Little Endian (Intel)" or "Big Endian (Motorola)") in the cyclic data; this setting applies to both input and output data (↪ section 8.4 "Communication protocol" on page 23).



We recommend selecting "Big Endian (Motorola)" for Siemens PLCs.

8.7.8 Automatic phase angle compensation (AUTOCOMP)

It may be necessary to compensate the phase angle displacement between the U_R and I_R measuring signals for specific heatsealing applications (↪ ROPEX Application Report). The AUTOCOMP function is provided for this purpose. The following settings are possible:

1. **"Off"** (factory setting)

The AUTOCOMP function is switched off.

2. **"On"**

The AUTOCOMP function is executed whenever the AUTOCAL function (↪ section 8.5.1 "Automatic zero calibration AUTOCAL (AC)" on page 23) is executed twice in quick succession. The interval between the end of the first AUTOCAL function and the start of the second AUTOCAL must be shorter than 2.0 seconds. The second AUTOCAL function only takes around 2.0 seconds and includes the AUTOCOMP function.

If the interval between the two AUTOCAL functions is longer than 2.0 seconds, AUTOCAL is executed normally again the second time.

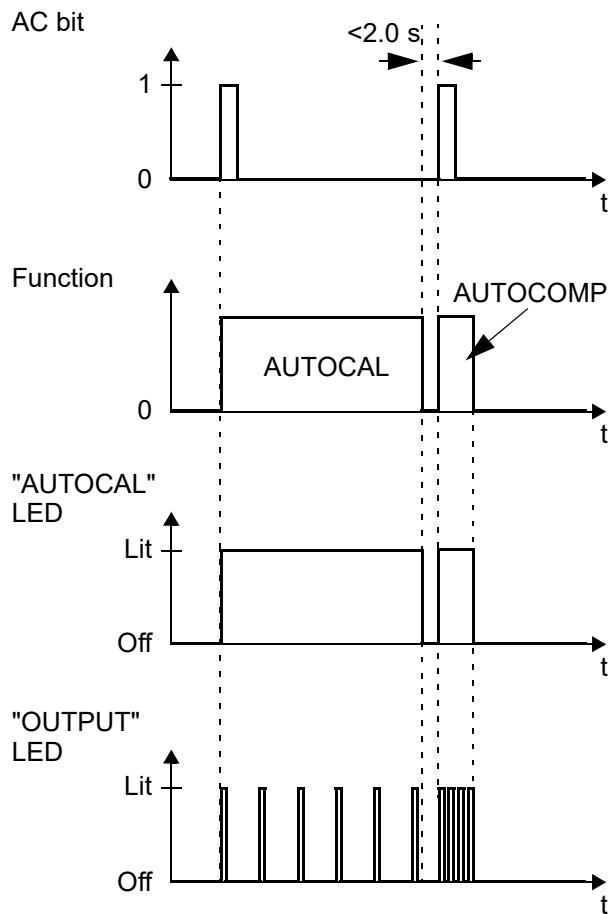

The "OUTPUT" LED blinks several times when the AUTOCOMP function is executed and the actual value output (terminals 17+18) changes to 0...3 °C (corresponds to approx. 0 VDC).

3. "AUTO"

This setting causes the AUTOCOMP function to be automatically activated after the AUTOCAL function has been successfully executed.

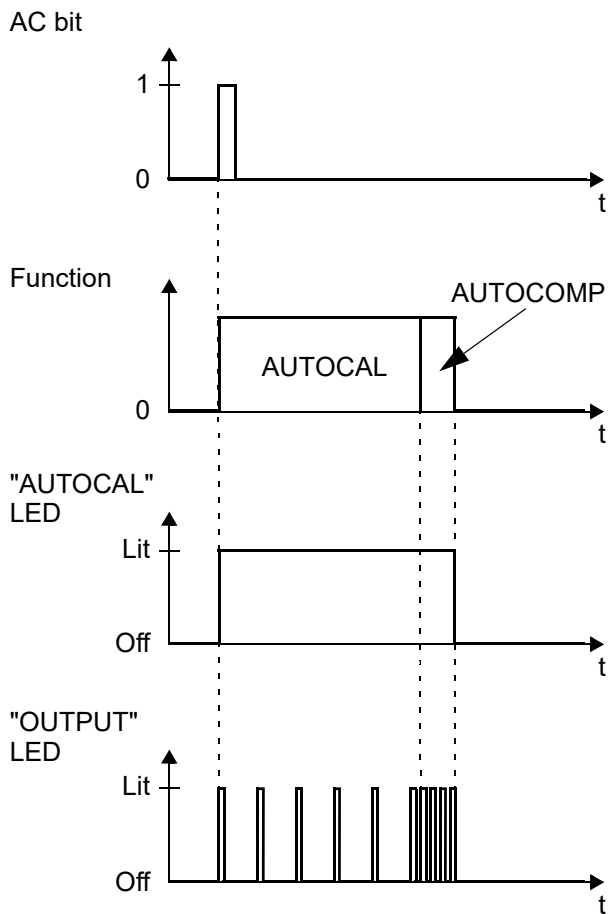

The "OUTPUT" LED blinks several times when the AUTOCOMP function is executed and the actual value output (terminals 17+18) changes to 0...3 °C (corresponds to approx. 0 VDC).

The AUTOCOMP function must be activated in the parameter data (↪ section 8.7 "Parameter object (class: 0x0F)" on page 28) (default setting: AUTOCOMP off).

8.7.9 Temperature diagnosis

An additional temperature diagnosis can be activated in the parameter data (EDS file). The RES-5011 checks whether the actual temperature is within a settable tolerance band ("OK" window) either side of the set temperature. The high ($\Delta\vartheta_{high}$) and low ($\Delta\vartheta_{low}$) tolerance limits are the same as for the "Temperature OK" function (TO bit ↪ section 8.6.6 "Temperature OK (TO)" on page 26). The limits are set to -10 K and +10 K by default. If the ACTUAL temperature is inside the specified tolerance band when the START signal is activated, the temperature diagnosis is activated as well. If the ACTUAL temperature leaves the tolerance band, the corresponding error code (307, 308) appears and the alarm relay is switched (↪ section 8.19 "Error messages" on page 63).

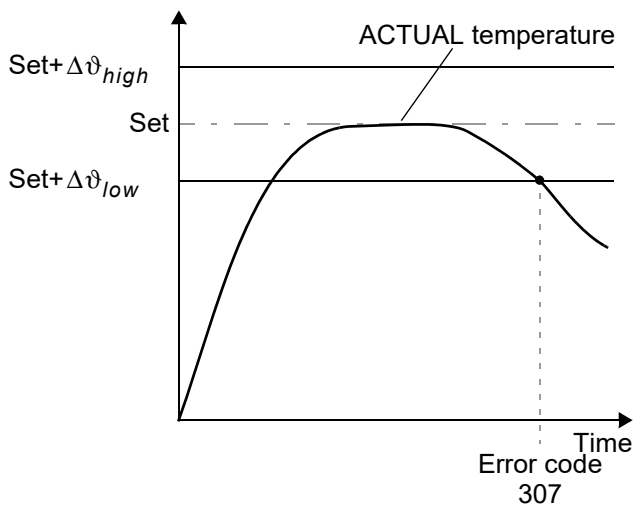

If the temperature diagnosis is not activated by the time the START signal is deactivated (i.e. if the ACTUAL temperature does not exceed the high or low tolerance band limit), the corresponding error code (309, 310) appears and the alarm relay is switched.

An additional delay time (0..9.9 s) can be set in the parameter data (EDS file). The first time the low tolerance limit is exceeded, the temperature diagnosis is not activated until the configured delay time has elapsed. The temperature diagnosis function can thus be selectively deactivated, e.g. if the temperature drops temporarily owing to the closure of the sealing jaws.

The high and low tolerance limits cannot be set in the ROPEX visualization software. The same limits apply as with the TO bit. They can only be set in the parameter data (↪ section 8.7 "Parameter object (class: 0x0F)" on page 28).

8.7.10 Heatup timeout

An additional heatup timeout can be activated in the parameter data (EDS file).

This timeout starts when the ST bit is set. The RES-5011 then monitors the time required for the ACTUAL temperature to reach 95% of the SET temperature. If this time is longer than the configured time, the corresponding error code (304) appears and the alarm relay is switched (↪ section 8.19 "Error messages" on page 63).

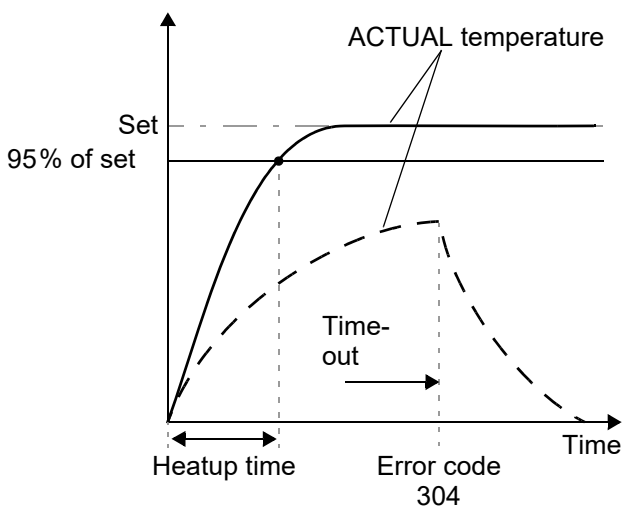

The "Heatup timeout" function must be enabled for use in the parameter data (↪ section 8.7 "Parameter object (class: 0x0F)" on page 28) (default setting: heatup timeout off).

8.7.11 Hold mode

The ACTUAL temperature output via the EtherNet/IP™ protocol can be configured in the parameter data (EDS file) as follows:

1. **"Off" (factory setting)**

The ACTUAL temperature is always output in real time.

2. **"On"**

The ACTUAL temperature that was valid at the end of the last heatsealing phase is output. When the controller is switched on, the real ACTUAL temperature is indicated up until the end of the first heating phase.

3. **"2 sec."**

This setting causes the current ACTUAL temperature to be output for an additional 2 seconds by means of the EtherNet/IP™ protocol at the end of a heatsealing phase. The ACTUAL temperature is then output again in real time until the end of the next heatsealing phase.

Hold mode only applies to the ACTUAL temperature which is output via the EtherNet/IP™ protocol and the digital temperature display in the ROPEX visualization software. It has no effect on the ACTUAL temperature that appears at the controller's analog output or is plotted in the graphics window of the ROPEX visualization software. The various hold modes are shown below:

ST bit

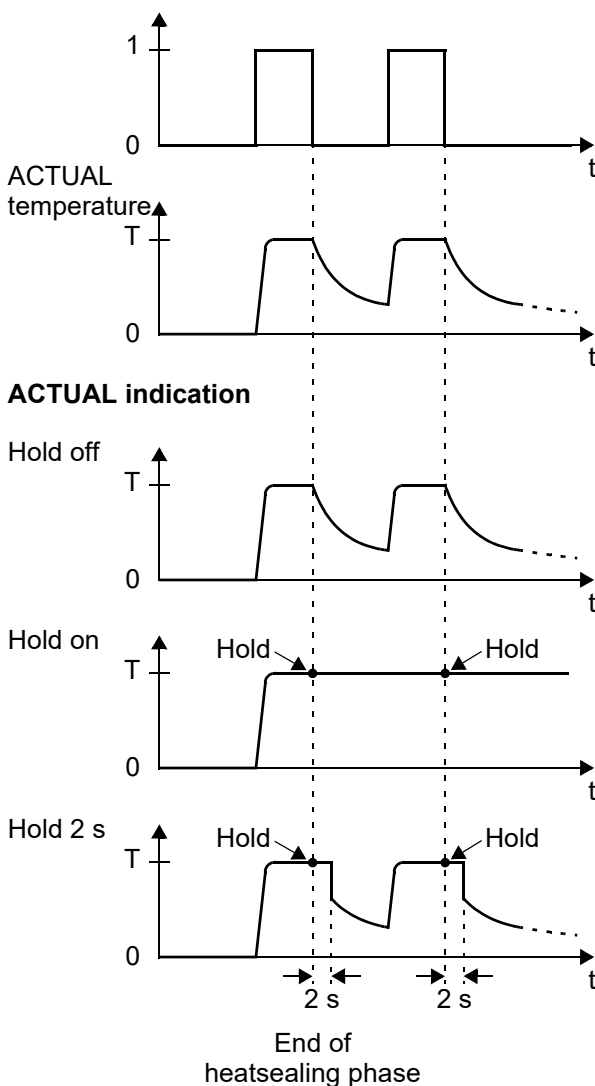

The "Hold mode" function must be activated in the parameter data (↪ section 8.7 "Parameter object (class: 0x0F)" on page 28) (default setting: hold mode off).

8.8 Integrated web server

The integrated web server enables quick and easy access to status information and parameter values of the temperature controller via the existing Ethernet connection. The device protocol can additionally be read out and displayed. A graph showing the last 5 seconds of a heating impulse allows a rapid qualitative evaluation of the controlled system.

The latest version of the operating instructions can be downloaded from the ROPEX website by clicking on the picture of the device on any page. To make sure this latest version is always available in any selectable language, the instructions are not stored in the device; you must therefore have an Internet connection in order to access the operating instructions.

You can go direct to the official ROPEX website by clicking on the ROPEX logo in the top right-hand corner.

The web server uses JavaScript and has been successfully tested with Internet Explorer 9, 10, and 11 as well as with Microsoft Edge. It also works with the latest version of the Safari and Firefox browsers.

8.8.1 Home page

This page contains general product information under "Device Information", for instance the product name, serial number, firmware version, MAC address, and real-time Ethernet protocol. You can also download the correct device description file for your product here (↪ section 8.3 "Device description file (EDS)" on page 22). No Internet connection is necessary to do this because the file is already stored in the device's internal memory.

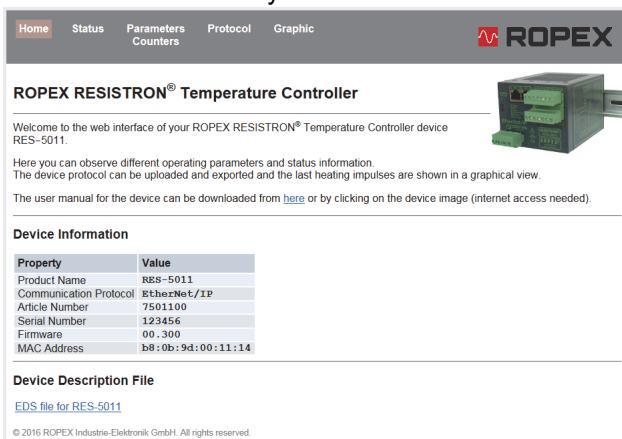

Home Status Parameters Counters Protocol Graphic 

ROPEX RESISTRON® Temperature Controller

Welcome to the web interface of your ROPEX RESISTRON® Temperature Controller device RES-5011.

Here you can observe different operating parameters and status information. The device protocol can be uploaded and exported and the last heating impulses are shown in a graphical view.

The user manual for the device can be downloaded from [here](#) or by clicking on the device image (internet access needed).

Device Information

Property	Value
Product Name	RES-5011
Communication Protocol	EtherNet/IP
Article Number	7501100
Serial Number	123456
Firmware	00.300
MAC Address	b8:0b:9d:00:11:14

Device Description File

[EDS file for RES-5011](#)

© 2016 ROPEX Industrie-Elektronik GmbH. All rights reserved.

8.8.2 Status page

This page provides an overview of the current controller status.

"Online" indicates whether a connection has been set up to the PLC.

The inputs (↩ section 8.5 "Input data" on page 23) are shown in the left-hand column, the outputs (↩ section 8.6 "Output data" on page 26) in the middle column, and the current status of all device LEDs (↩ section 8.1 "LEDs and controls" on page 20) in the right-hand column.

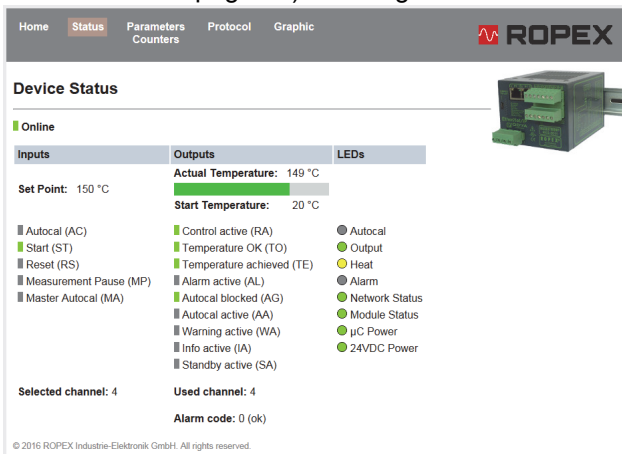

8.8.3 Parameters / Counters page

This page shows all parameter values received by the temperature controller from the EtherNet/IP™ scanner. If the parameters have been changed using acyclic services, these changes are also indicated here.

For the meanings of the parameter data, refer to section 8.7 "Parameter object (class: 0x0F)" on page 28.

Under "Counters" you see a list of all cycle and operating hours counters, which are useful for statistical purposes.

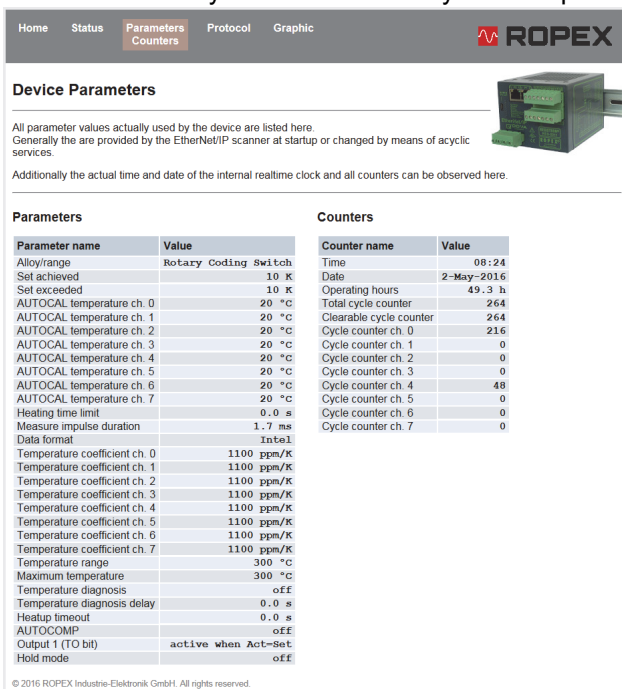

Parameters		Counters	
Parameter name	Value	Counter name	Value
Alloy/range	Rotary Coding Switch	Time	08:24
Self achieved	10 K	Date	2-May-2016
Set exceeded	10 K	Operating hours	49.3 h
AUTOCAL temperature ch. 0	20 °C	Total cycle counter	264
AUTOCAL temperature ch. 1	20 °C	Clearable cycle counter	264
AUTOCAL temperature ch. 2	20 °C	Cycle counter ch. 0	216
AUTOCAL temperature ch. 3	20 °C	Cycle counter ch. 1	0
AUTOCAL temperature ch. 4	20 °C	Cycle counter ch. 2	0
AUTOCAL temperature ch. 5	20 °C	Cycle counter ch. 3	0
AUTOCAL temperature ch. 6	20 °C	Cycle counter ch. 4	48
AUTOCAL temperature ch. 7	20 °C	Cycle counter ch. 5	0
Heating time limit	0.0 s	Cycle counter ch. 6	0
Measure impulse duration	1.7 ms	Cycle counter ch. 7	0
Data format	Intel		
Temperature coefficient ch. 0	1100 ppm/K		
Temperature coefficient ch. 1	1100 ppm/K		
Temperature coefficient ch. 2	1100 ppm/K		
Temperature coefficient ch. 3	1100 ppm/K		
Temperature coefficient ch. 4	1100 ppm/K		
Temperature coefficient ch. 5	1100 ppm/K		
Temperature coefficient ch. 6	1100 ppm/K		
Temperature coefficient ch. 7	1100 ppm/K		
Temperature range	300 °C		
Maximum temperature	300 °C		
Temperature diagnosis	off		
Temperature diagnosis delay	0.0 s		
Heatup timeout	0.0 s		
AUTOCOMP	off		
Output 1 (TO bit)	active when Act=Set		
Hold mode	off		

8.8.4 Protocol page

You can download and display the device protocol for the temperature controller on this page. You see the overall size of the protocol ("Total event entries") as well as the upload progress. All entries appear in the form of a table. A timestamp (generated by the built-in clock), the operating hours and cycle counters, and the channel selected at the time are shown for each entry.

In addition to errors, the protocol also contains entries of general interest such as "Clock set" or the AUTOCAL function. An error code provides information on the cause of all events in the protocol. The error codes are

described in detail in section 8.19 "Error messages" on page 63. Each error code is explained in a tooltip when you hover over it briefly.

The data can also be exported to a CSV file to enable further processing in another software program. By clicking on the appropriate button you can select a comma separated format or a semicolon separated format.

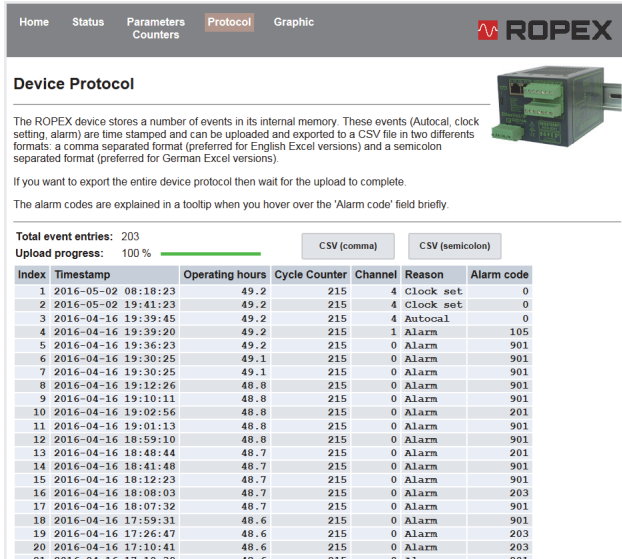

Device Protocol

The ROPEX device stores a number of events in its internal memory. These events (Autoclock setting, alarm) are time stamped and can be uploaded and exported to a CSV file in two different formats: a comma separated format (preferred for English Excel versions) and a semicolon separated format (preferred for German Excel versions).

If you want to export the entire device protocol then wait for the upload to complete.

The alarm codes are explained in a tooltip when you hover over the 'Alarm code' field briefly.

Total event entries: 203
Upload progress: 100 %

CSV (comma) CSV (semicolon)

Index	Timestamp	Operating hours	Cycle Counter	Channel	Reason	Alarm code
1	2016-05-02 08:18:23	49.2	215	4	Clock set	0
2	2016-05-02 19:41:23	49.2	215	4	Clock set	0
3	2016-04-16 19:39:45	49.2	215	4	Autoclock	0
4	2016-04-16 19:39:20	49.2	215	1	Alarm	105
5	2016-04-16 19:36:23	49.2	215	0	Alarm	901
6	2016-04-16 19:30:25	49.1	215	0	Alarm	901
7	2016-04-16 19:30:25	49.1	215	0	Alarm	901
8	2016-04-16 19:12:26	48.8	215	0	Alarm	901
9	2016-04-16 19:10:11	48.8	215	0	Alarm	901
10	2016-04-16 19:09:56	48.8	215	0	Alarm	201
11	2016-04-16 19:01:13	48.8	215	0	Alarm	901
12	2016-04-16 18:59:10	48.8	215	0	Alarm	901
13	2016-04-16 18:48:44	48.7	215	0	Alarm	201
14	2016-04-16 18:41:48	48.7	215	0	Alarm	901
15	2016-04-16 18:12:23	48.7	215	0	Alarm	901
16	2016-04-16 18:08:03	48.7	215	0	Alarm	203
17	2016-04-16 18:07:32	48.7	215	0	Alarm	901
18	2016-04-16 17:59:31	48.6	215	0	Alarm	901
19	2016-04-16 17:26:47	48.6	215	0	Alarm	203
20	2016-04-16 17:10:41	48.6	215	0	Alarm	203
21	2016-04-16 17:10:38	48.6	215	0	Alarm	201

The download may take a few seconds, depending on the number of entries which are stored here. The newest events appear at the top of the list.

If any new events occur while this page is displayed, you do not see them until you refresh the list by clicking on the "Protocol" menu again.

8.8.5 Graphic page

The temperature controller has an internal memory which can store temperature curves over a period of up to 5 seconds. This memory is automatically filled when the ST bit is set. You can display or export the memory contents on the Graphic page.

By clicking on "Refresh", you cause the graphic data to be downloaded from the memory of the temperature controller and displayed again.

"Clear" clears all data from the memory (disconnecting the 24 VDC supply voltage has the same effect).

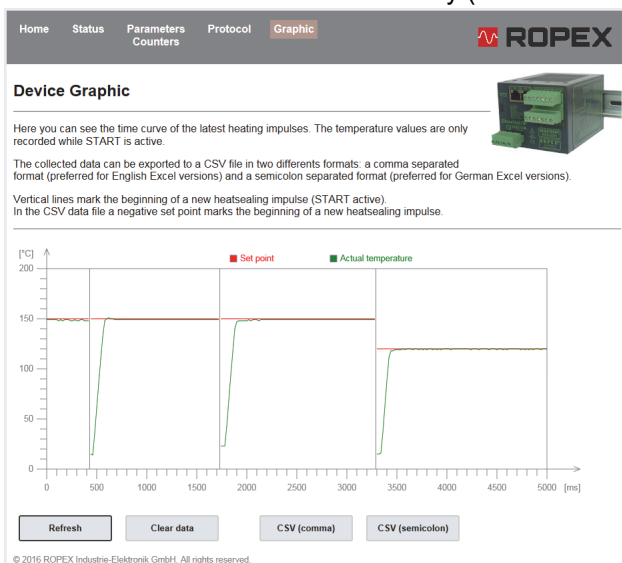

Device Graphic

Here you can see the time curve of the latest heating impulses. The temperature values are only recorded while START is active.

The collected data can be exported to a CSV file in two different formats: a comma separated format (preferred for English Excel versions) and a semicolon separated format (preferred for German Excel versions).

Vertical lines mark the beginning of a new heatsealing impulse (START active).
In the CSV data file a negative set point marks the beginning of a new heatsealing impulse.

Refresh Clear data CSV (comma) CSV (semicolon)

© 2016 ROPEX Industrie-Elektronik GmbH. All rights reserved.

The vertical lines mark the beginning of a new heatsealing impulse (ST bit set). A negative set point indicates the start of a new impulse in the exported data. Cooling processes are not normally visible because they take place when the ST bit is reset.

8.8.6 Calibration page

 This page is first available as from firmware version 303.

The temperature controller stores the absolute calibration resistance of each channel (Calibration resistance ch. 0...7) with an resolution of 0.1 mΩ.

The calculation of the respective calibration resistance is done at the end of the AUTOCAL function (↪ section 8.5.1 "Automatic zero calibration AUTOCAL (AC)" on page 23).

The initial calibration resistances (Initial calibration resistance ch. 0...7) are calculated if the Master-AUTOCAL function is executed (↪ section 8.5.5 "Master AUTOCAL (MA)" on page 25).

These initial calibration resistances are the basis for the calculation of the calibration deviation. Each execution of the AUTOCAL function will calculate both, the absolute calibration resistance and likewise the percentual calibration deviation towards the initial calibration resistance.

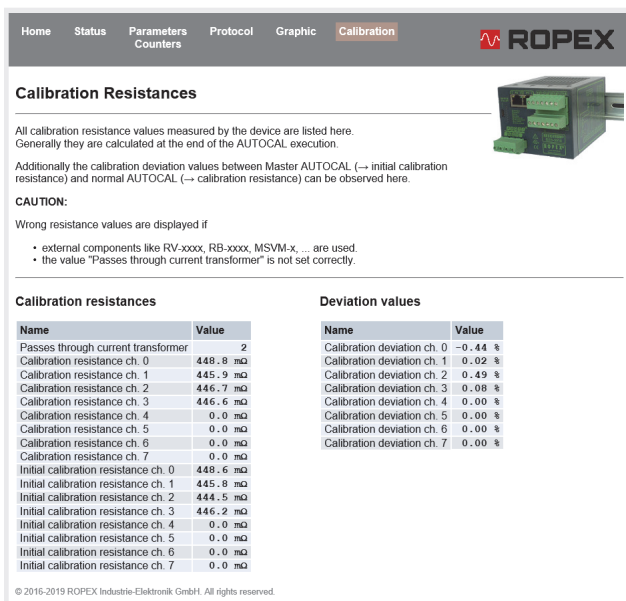

The screenshot shows the 'Calibration' page in the ROPEX interface. It includes a navigation bar with 'Home', 'Status', 'Parameters Counters', 'Protocol', 'Graphic', and 'Calibration'. The main content area is titled 'Calibration Resistances' and contains explanatory text, a caution note, and two tables: 'Calibration resistances' and 'Deviation values'. A small image of the device is also present.

Calibration resistances		Deviation values	
Name	Value	Name	Value
Passes through current transformer	2	Calibration deviation ch. 0	-0.44 %
Calibration resistance ch. 0	448.8 mΩ	Calibration deviation ch. 1	0.02 %
Calibration resistance ch. 1	445.9 mΩ	Calibration deviation ch. 2	0.49 %
Calibration resistance ch. 2	446.7 mΩ	Calibration deviation ch. 3	0.08 %
Calibration resistance ch. 3	446.6 mΩ	Calibration deviation ch. 4	0.00 %
Calibration resistance ch. 4	0.0 mΩ	Calibration deviation ch. 5	0.00 %
Calibration resistance ch. 5	0.0 mΩ	Calibration deviation ch. 6	0.00 %
Calibration resistance ch. 6	0.0 mΩ	Calibration deviation ch. 7	0.00 %
Calibration resistance ch. 7	0.0 mΩ		
Initial calibration resistance ch. 0	448.6 mΩ		
Initial calibration resistance ch. 1	445.8 mΩ		
Initial calibration resistance ch. 2	444.5 mΩ		
Initial calibration resistance ch. 3	446.2 mΩ		
Initial calibration resistance ch. 4	0.0 mΩ		
Initial calibration resistance ch. 5	0.0 mΩ		
Initial calibration resistance ch. 6	0.0 mΩ		
Initial calibration resistance ch. 7	0.0 mΩ		

© 2016-2019 ROPEX Industrie-Elektronik GmbH. All rights reserved.

These values are displayed on the Calibration page.

Additionally the actual value of „passes through current transformer“ are displayed. This value can be read or written by means of acyclic services. Set this value to the real wire passes through the current transformer for that the absolute resistance values can be calculated correctly. This value has no influence on the calculation of the percentual calibration deviation.

 The calculation of the absolute resistance values is liable to variation and imprecision due to tolerances in production, to application dimensioning, to quality of cabling, to fluctuations in the power supply, etc.

8.9 Undervoltage detection

Trouble-free operation of the temperature controller is guaranteed within the line voltage and 24 VDC supply voltage tolerances specified in section 10 "Technical data" on page 69.

If the 24 VDC supply voltage drops below the permitted lower limit, the controller is switched to standby mode. No more heatsealing processes take place and no more measuring impulses are generated. Normal operation is resumed when the input voltage returns to the specified tolerance range again.

Standby mode is indicated by 0...3 °C (i.e. approx. 0 V) at the analogue output. In addition, the SA bit is set in the status word for the cyclic output data.

! Trouble-free operation of the controller is only guaranteed within the specified tolerance range of the input voltage. An external voltage monitor must be connected to prevent low line or 24 VDC supply voltage from resulting in defective heatseals.

8.10 Temperature meter (actual value output)

The RES-5011 supplies an analog 0...10 VDC signal, which is proportional to the real ACTUAL temperature, at terminals 17+18.

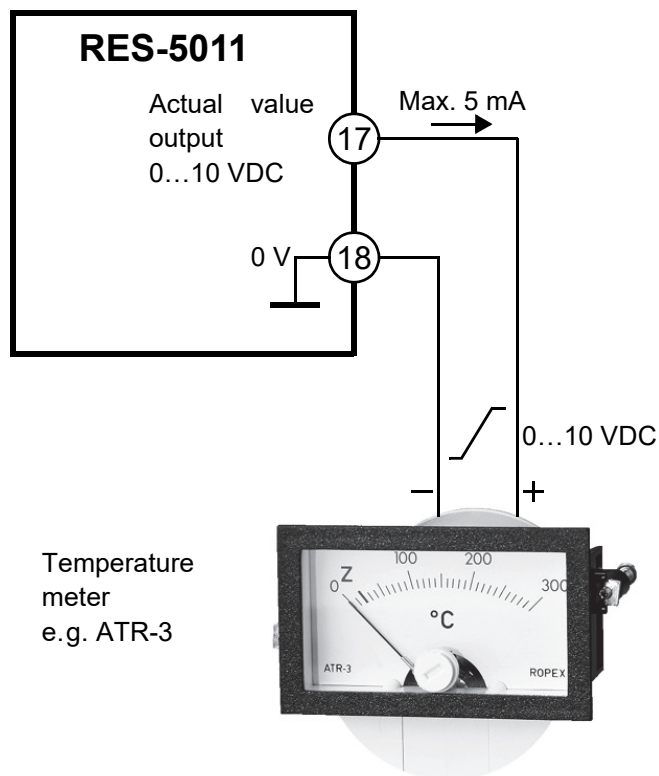

Voltage values:

- 0 VDC → 0 °C
- 10 VDC → 300 °C or 500 °C, depending on the device configuration

The relationship between the change in the output voltage and the ACTUAL temperature is linear.

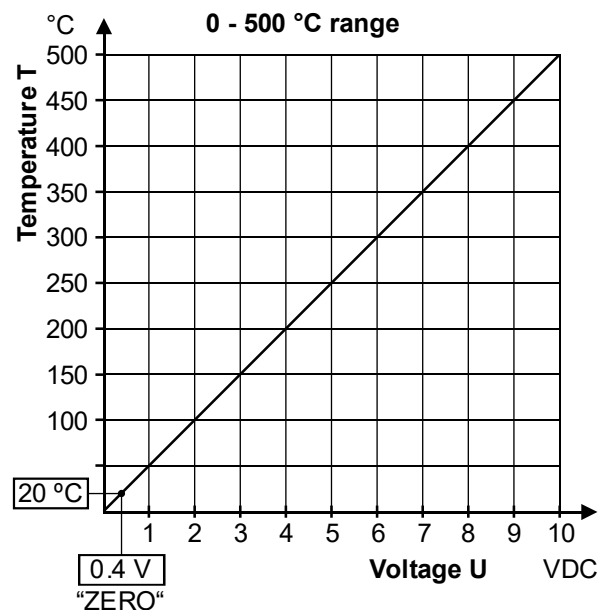
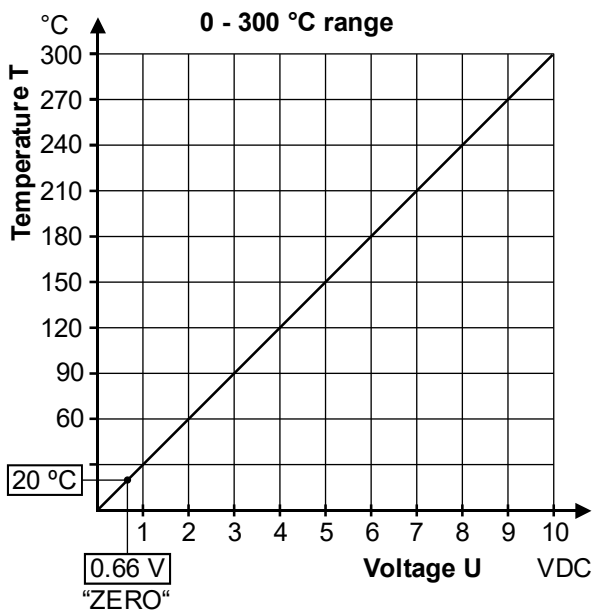

An indicating instrument can be connected to this output in order to visualize the temperature of the heatsealing band.

The ROPEX ATR-x temperature meter is optimally adapted to this application in every respect (size, scale, dynamic behavior) and can be used for this, if needed (↪ section 6 "Mounting and installation" on page 8).

The meter not only facilitates SET-ACTUAL comparisons but also enables other criteria such as the heating rate, set point achieved within the specified time, cooling of the heatsealing band etc. to be evaluated.

The temperature meter additionally permits disturbances in the control loop (loose connections, contacting or wiring problems) as well as any line disturbances to be observed extremely efficiently and interpreted accordingly.

The same applies if several neighbouring control loops interfere with one another.

If a fault is signalled, this analog output is used to display a selective error message (↪ section 8.19 "Error messages" on page 63).

8.11 Booster connection

The RES-5011 controller has a connection for an external switching amplifier (booster) as standard. This connection (at terminals 15+16) is necessary for high primary currents (continuous current > 5 A, pulsed current > 25 A). The booster should be connected as described in section 6.7 "Wiring diagram with booster connection" on page 14.



The connecting cable to the booster must not be longer than 1 m; it must also be twisted in order to reduce EMC interference to a minimum.

8.12 USB interface for visualization software ROPEXvisual®

A USB interface (type: Micro USB) is provided for system diagnostics and process visualization. This USB interface enables a data connection to be set up to ROPEXvisual®, the ROPEX visualization software.

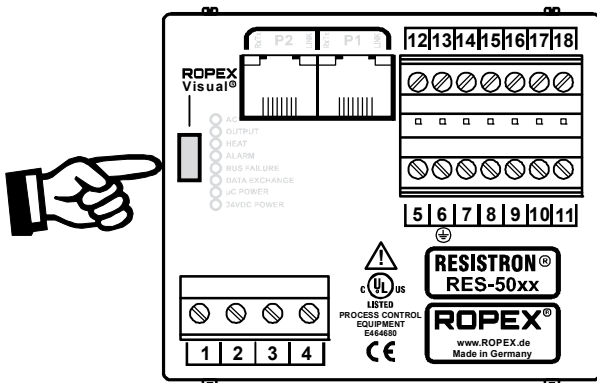

The ROPEX visualization software is described in a separate document. The software and the documentation are available in the [download area](#) (search term: "Visual").

8.13 AUX interface

Internal interface for diagnostics and maintenance. This interface is not currently available.

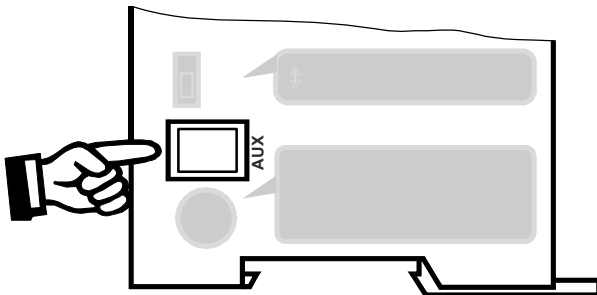

8.14 Total cycle counter

The number of heatsealing cycles executed since the controller was shipped is stored in the internal memory (ST bit = 1). This is a read-only counter which cannot be reset. It can be displayed in the ROPEX visualization software (↪ section 8.12 "USB interface for visualization software ROPEXvisual®" on page 61), via the integrated web server, or using the acyclic services of the EtherNet/IP™ interface.

8.15 Operating hours counter

The number of operating hours since the controller was shipped is stored in the internal memory. This counter works with a resolution of six minutes. It is a read-only counter which cannot be reset. It can be displayed in the ROPEX visualization software (↪ section 8.12 "USB interface for visualization software ROPEXvisual®" on page 61), via the integrated web server, or using the acyclic services of the EtherNet/IP™ interface.

8.16 Data memory for error messages and AUTOCAL

To simplify error diagnoses during operation, the RES-5011 controller has a data memory for error messages (↪ section 8.19 "Error messages" on page 63) and executed AUTOCAL functions (↪ section 8.5.1 "Automatic zero calibration AUTOCAL (AC)" on page 23).

The 400 most recent messages are stored. They can be read out and displayed in the ROPEX visualization software (↪ section 8.12 "USB interface for visualization software ROPEXvisual[®]" on page 61) or via the integrated web server.

The RES-5011 also features a built-in clock (↪ section 8.17 "Built-in clock (date and time)" on page 62). All messages are saved in the data memory together with their date and time of occurrence (timestamp).



The stored messages can be exported as a csv-file. If needed, ROPEX can evaluate the exported file and create an error diagnosis.

8.17 Built-in clock (date and time)

The RES-5011 has a built-in clock. All messages are saved in the data memory (↪ section 8.16 "Data memory for error messages and AUTOCAL" on page 62) together with their date and time of occurrence (timestamp). Error messages can thus be interpreted more accurately whenever a problem needs to be analyzed.

The built-in clock can be set and read out in the ROPEX visualization software (↪ section 8.12 "USB interface for visualization software ROPEXvisual[®]" on page 61) or using the acyclic services of the EtherNet/IP[™] interface. The date and time can be read out but not set via the integrated server.

A maintenance-free capacitor is used to operate the clock. There is no battery that has to be replaced every now and then.

The controller must remain switched on for at least three hours to make sure the clock's capacitor is fully charged. When the controller is switched off, the fully charged capacitor can keep the clock running for approximately 2...4 weeks. If the controller is switched off for longer, the date and time will have to be set again. You can do this in the ROPEX visualization software (↪ section 8.12 "USB interface for visualization software ROPEXvisual[®]" on page 61) or using the acyclic services of the EtherNet/IP[™] interface.

The capacitor is not charged when it leaves the factory. When the controller is started up, you must set the clock if you want error messages to be saved in the data memory (↪ section 8.16 "Data memory for error messages and AUTOCAL" on page 62) together with their date and time of occurrence.

The controller can also be operated without the clock. In this case, the dates and times that are saved in the data memory will be invalid (↪ section 8.16 "Data memory for error messages and AUTOCAL" on page 62). However, this has no effect on the temperature control functions.

8.18 System monitoring / alarm output

To increase operational safety and avoid faulty heatsealing, this controller incorporates special hardware and software features to facilitate selective error detection and diagnosis. Both the external wiring and the internal system are monitored.

These features significantly assist the operator in identifying the cause of abnormal situations.

A system fault is reported or differentiated by means of the following indications.

A.) Red "ALARM" LED on the controller with three states:

1. Blinking fast (4 Hz):

The AUTOCAL function should be executed (error codes 104...106, 211, 302, 303).

2. Blinking slowly (1 Hz):

The system configuration is incorrect and the zero calibration (AUTOCAL function) was unsuccessful (↪ section 7.2 "Device configuration" on page 15). This corresponds to error codes 111...114).

3. Lit continuously:

A fault is preventing the system from starting (error codes 101...103, 107, 108, 201...203, 304, 307, 308, 9xx).
As a rule, this refers to an external wiring fault.

B.) Alarm relay (relay contact terminals 12+13+14):

This relay is set at the factory as follows:

- **DE-ENERGIZED** in operating states A.1 and A.2 but energized if a START signal is present in one of these states.
- **ENERGIZED** in operating state A.3.

 **If the alarm relay has the opposite configuration to the factory setting (↪ section 7.2.3 "Configuration of the rotary coding switch for the IP address" on page 16), these states are reversed.**

C.) Error code indicated via the EtherNet/IP™ protocol:

If an error occurs, the AL bit is set and possibly also the WA bit. The error code is contained in the third word at bit positions 0...9 (↪ section 8.6.12 "Error codes" on page 28).

D.) Error code indicated via the actual value output 0...10 VDC (terminals 17+18):

Since a temperature indication is no longer necessary if a fault occurs, the actual value output is used to display error messages whenever a fault is signaled.

Thirteen voltage levels are available for this purpose in the 0...10 VDC range, each of which is assigned an error code (↪ section 8.19 "Error messages" on page 63).

For statuses that require AUTOCAL, or if the device configuration is incorrect (error codes 104...106, 111...114, 211, 302, 303), the signal at the actual value output jumps back and forth at 1 Hz between the voltage value corresponding to the error and the end of the scale (10 VDC, i.e. 300 °C or 500 °C). If the START signal is present in one of these states, the voltage value does not change any more.

If a ROPEX temperature meter (e.g. an ATR-x) is connected to the controller's analog output, the temperature indication can be directly assigned to the error codes if an alarm is signaled.

An error message can be reset by setting the RS bit or by momentarily interrupting the power to the controller (24 VDC supply voltage).

If an error message is reset with the RS bit, it is not actually reset until the RS bit is reset.

Invalid error messages may appear when the controller is switched off owing to the undefined operating state. This must be taken into account when they are evaluated by the higher-level controller (e.g. a PLC) in order to avoid false alarms.

8.19 Error messages

The table below shows the meaning of the error codes. It includes a description of each error as well as the required corrective action.

The block diagram in section 8.20 "Fault areas and causes" on page 67 helps you clear a particular error quickly and efficiently.

Thirteen voltage levels for diagnosing errors appear at the RESISTRON® temperature controller's actual value output. The error messages are even more finely differentiated internally. The 3-digit error codes described below can be displayed via the EtherNet/IP™ interface or in the ROPEX visualization software (↪ section 8.12 "USB interface for visualization software ROPEXvisual®" on page 61) to facilitate troubleshooting).

 **If the actual value output is evaluated in order to identify an error message – in the higher-level controller, for instance – the tolerance window must be adjusted to prevent incorrect interpretations. Please note the tolerances of the actual value output (↪ section 10 "Technical data" on page 69).**

Part 1 of 3: Error messages (faults)

NOTE: The error messages shown here are output as faults (constant error voltage at actual value output, alarm LED lit continuously, alarm relay energized).

Error code	Act. val. output voltage [V]	Cause	Action if machine started for first time	Action if machine already operated, HS band not changed
101	0.66	No current signal	Fault area ①	Fault area ①
102	1.33	No voltage signal	Fault area ③	Fault area ③
103	2.00	No current / voltage signals	Fault area ②	Fault areas ②⑨
107	2.66	Temperature step, down	Fault areas ④⑤⑥ ("loose contact")	Fault areas ④⑤⑥ ("loose contact")
108		Temperature step, up		
307		Temperature too high / low (↪ section 8.7.9)	-	-
308				
309				
310				
201	3.33	No line frequency / line frequency fluctuates	Check power supply	Check power supply
202		Line frequency too high / fluctuates		
203		Line frequency too low / fluctuates		
304	4.00	Heatup time too long (↪ section 8.7.10)	Perform RESET	Perform RESET
901	4.66	No line voltage / sync signal	↪ Section 8.2	↪ Section 8.2
913		Triac defective	Replace device	Replace device
914		Internal fault, device defective	Replace device	Replace device
915				
916				
917	Jumper for alarm output incorrect	Check jumper	Check jumper	
918				

Part 2 of 3: Error messages (warnings)

NOTE: The specified error messages are initially output as warnings (actual value output jumps back and forth between two values, alarm LED blinks, alarm relay de-energized). When the START signal is activated, the warning changes to a fault (actual value output no longer jumps back and forth, see bold italic values, alarm LED lit continuously, alarm relay energized).

Error code	Act. val. output voltage [V]	Cause	Action if machine started for first time	Action if machine already operated, HS band not changed
104	↔ 5.33 ↔ ↔ 10 ↔	Current signal incorrect, incorrect impulse transformer specification	Perform AUTOCAL , check transformer specification, fault areas ⑦ ⑧	Fault areas ④ ⑤ ⑥ ("loose contact")
105		Voltage signal incorrect, incorrect impulse transformer specification		
106		Current and voltage signals incorrect, incorrect impulse transformer specification		
302		Temperature too low, calibration not performed, loose contact, ambient temp. fluctuates	Perform AUTOCAL and / or	
303		Temperature too high, calibration not performed, loose contact, ambient temp. fluctuates	fault areas ④ ⑤ ⑥ ("loose contact")	
211	↔ 6.00 ↔ ↔ 10 ↔	Data error	Perform AUTOCAL	Perform AUTOCAL

Part 3 of 3: Error messages (warnings)

NOTE: The specified error messages are initially output as warnings (actual value output jumps back and forth between two values, alarm LED blinks, alarm relay de-energized). When the START signal is activated, the warning changes to a fault (actual value output no longer jumps back and forth, see bold italic values, alarm LED lit continuously, alarm relay energized).

Error code	Act. val. output voltage [V]	Cause	Action if machine started for first time	Action if machine already operated, HS band not changed
111	<i>↔ 6.66 ↔</i> ↕ 10 ↗	Current signal incorrect, no calibration possible	Fault area ⑧, check configuration	Fault areas ④ ⑤ ⑥ ("loose contact")
112	<i>↔ 7.33 ↔</i> ↕ 10 ↗	Voltage signal incorrect, no calibration possible	Fault area ⑦, check configuration	Fault areas ④ ⑤ ⑥ ("loose contact")
113	<i>↔ 8.00 ↔</i> ↕ 10 ↗	Current / voltage signals incorrect, no calibration possible	Fault area ⑦ ⑧, check configuration	Fault areas ④ ⑤ ⑥ ("loose contact")
114	<i>↔ 8.66 ↔</i> ↕ 10 ↗	Temperature fluctuates, no calibration possible	Perform AUTOCAL and / or fault areas ④ ⑤ ⑥ ("loose contact")	Perform AUTOCAL and / or fault areas ④ ⑤ ⑥ ("loose contact")
115		Ext. calibration temp. too high, no calibration possible	Perform AUTOCAL with ext. calibration temperature ≤ 40 °C	Perform AUTOCAL with ext. calibration temperature ≤ 40 °C
116		Ext. calibration temp. fluctuates, no calibration possible	Perform AUTOCAL with stable ext. calibration temperature	Perform AUTOCAL with stable ext. calibration temperature

8.20 Fault areas and causes

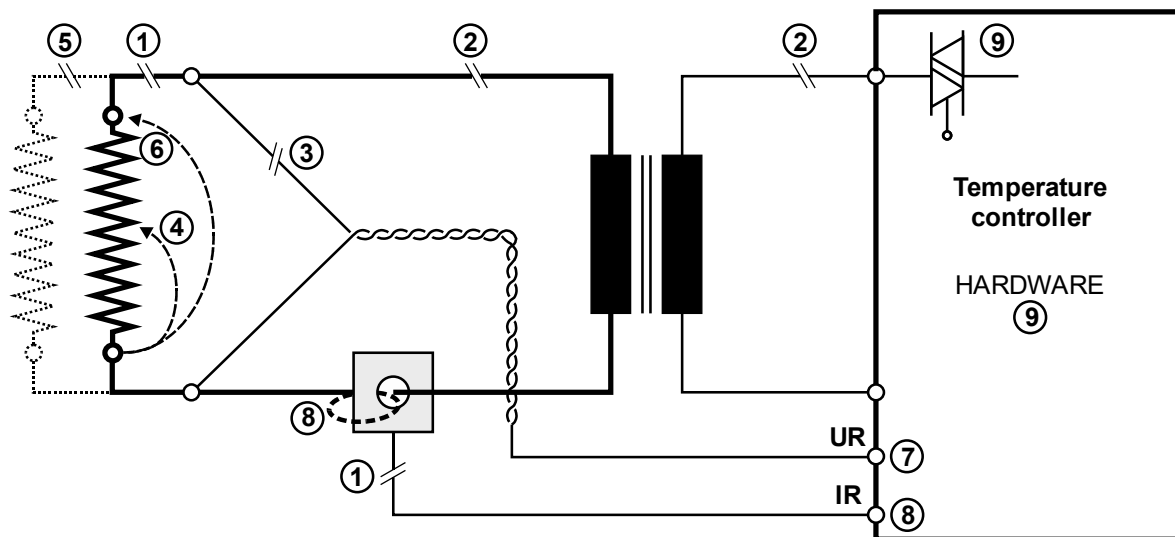





The table below explains the possible fault causes.

Fault area	Explanation	Possible causes
①	Load circuit interrupted after U_R pickoff point	- Wire break, heatsealing band break - Contact to heatsealing band is defective
	Current transformer signal interrupted	- I_R measurement cable from current transformer interrupted
②	Primary circuit interrupted	- Wire break, triac in controller defective - Primary winding of impulse transformer interrupted - Kb contactor open
	Secondary circuit interrupted before U_R pickoff point	- Wire break - Secondary winding of impulse transformer interrupted
③	No U_R signal	- Measurement cable interrupted
④	Partial short-circuit (ΔR)	- Heatsealing band partially bypassed by conducting part (clamp, opposite heatsealing bar etc.)
⑤	Parallel circuit interrupted	- Wire break, heatsealing band break - Contact to heatsealing band is defective
⑥	Total short-circuit	- Heatsealing band incorrectly installed, no insulation at heatsealing bar ends or insulation incorrectly installed - Heatsealing band completely bypassed by conducting part
⑦	U_R signal incorrect	- U_2 outside of permissible range from 0.4...120 VAC
⑧	I_R signal incorrect	- I_2 outside of permissible range from 30...500 A
	Wire incorrectly laid through current transformer	- Check number of turns (two or more turns required for currents < 30 A)

Fault area	Explanation	Possible causes
⑨	Internal device fault / no line voltage	<ul style="list-style-type: none">- Hardware fault (replace controller)- Jumper for alarm relay not connected or incorrectly connected- No line voltage

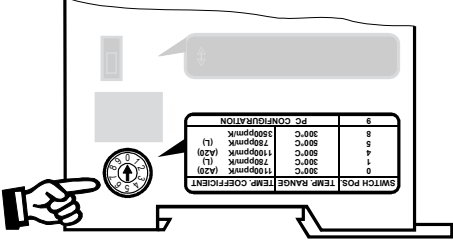
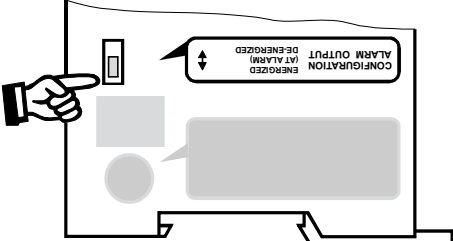
9 Factory settings



The RESISTRON® temperature controller RES-5011 is configured at the factory as follows:



<p><u>Rotary coding switch</u> for heatsealing band alloy and temperature range</p>	 <table border="1" data-bbox="667 524 879 607"> <thead> <tr> <th>SWITCH POS.</th> <th>TEMP. RANGE</th> <th>TEMP. COEFFICIENT</th> </tr> </thead> <tbody> <tr> <td>0</td> <td>300°C</td> <td>110ppm/K (A20)</td> </tr> <tr> <td>1</td> <td>300°C</td> <td>170ppm/K (L)</td> </tr> <tr> <td>4</td> <td>300°C</td> <td>170ppm/K (L)</td> </tr> <tr> <td>5</td> <td>300°C</td> <td>170ppm/K (L)</td> </tr> <tr> <td>8</td> <td>300°C</td> <td>170ppm/K (L)</td> </tr> <tr> <td>9</td> <td>300°C</td> <td>170ppm/K (L)</td> </tr> </tbody> </table>	SWITCH POS.	TEMP. RANGE	TEMP. COEFFICIENT	0	300°C	110ppm/K (A20)	1	300°C	170ppm/K (L)	4	300°C	170ppm/K (L)	5	300°C	170ppm/K (L)	8	300°C	170ppm/K (L)	9	300°C	170ppm/K (L)	<p>Heatsealing band alloy: Alloy 20 Temperature range: 300 °C</p> <p>Rotary coding switch: "0" position</p>
SWITCH POS.	TEMP. RANGE	TEMP. COEFFICIENT																					
0	300°C	110ppm/K (A20)																					
1	300°C	170ppm/K (L)																					
4	300°C	170ppm/K (L)																					
5	300°C	170ppm/K (L)																					
8	300°C	170ppm/K (L)																					
9	300°C	170ppm/K (L)																					
<p><u>Slide switch</u> for alarm relay</p>		<p>Alarm relay energized at alarm</p>																					
<p><u>Automatic phase angle compensation</u> (AUTOCOMP)</p>		<p>AUTOCOMP: Off</p>																					
<p><u>Temperature diagnosis</u></p>		<p>Temperature diagnosis: Off</p>																					
<p><u>Heatup timeout</u></p>		<p>Heatup timeout: Off</p>																					

10 Technical data

 **Operation of the temperature controller outside of these technical specifications results in loss of warranty and can cause defects.**

<p>Type of construction</p>	<p>Housing for installation in an electrical cabinet Snaps onto a standard top hat rail (TS35 rail, 35 mm) acc. to DIN EN 50022 Dimensions: 90 x 75 mm; depth: 135 mm (incl. terminals)</p>
------------------------------------	---

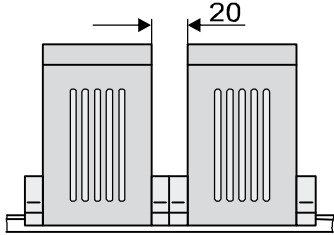
Line voltage	<p>Connected between neutral conductor and one line conductor: 110 VAC -15%...300 VAC +10%</p> <p>or</p> <p>Connected between two line conductors: 110 VAC -15%...415 VAC +10%</p> <p> The voltage between the line conductor and ground must not be more than 300 VAC.</p>
Power supply system	<p>Balanced TN or TT system, max. 415 VAC Installation category III</p> <p> Operation in potential-free systems (e.g. an IT system) is only permitted after consultation with ROPEX.</p>
Line frequency	<p>47...63 Hz, automatic adjustment to frequencies in this range</p>
Current consumption (primary current of impulse transformer)	<p>$I_{\max} = 5 \text{ A}$ (duty cycle = 100%) $I_{\max} = 25 \text{ A}$ (duty cycle = 20%, cycle duration 1 min)</p>
24 VDC supply voltage Terminals 5+7	<p>24 VDC, $I_{\max} = 200 \text{ mA}$ Tolerance: $\pm 10\%$ SELV or PELV supplied from max. 300 VAC, Cat II</p>
Measuring range	<p>Secondary voltage U_R: 0.4...120 VAC Secondary current I_R: 30...500 A (with PEX-W4/-W5 current transformer) ↳ ROPEX Application Report</p>
EtherNet/IP™ interface	<p>2 Ethernet switch ports RJ45 Wiring: IEC 61784-5-3 Data transfer rate: 10 or 100 Mbit/s Data transport layer: Ethernet II, IEEE 802.3 Addressing: DHCP or selectable with rotary coding switch ACD and DLR support: Yes</p>
Heatsealing band type and temperature range	<p>The temperature range and temperature coefficient settings can also be specified in the ROPEX visualization software (↳ section 8.12 "USB interface for visualization software ROPEXvisual®" on page 61) in addition to using the rotary coding switch or via the EtherNet/IP™ interface (see below):</p> <p>Temperature range: 200 °C, 300 °C, 400 °C, or 500 °C Temperature coefficient: 400...4000 ppm/K (variable setting range)</p> <p>Five different ranges can be set using the rotary coding switch or via the EtherNet/IP™ interface:</p> <p>Temperature coefficient 1100 ppm/K, 0...300 °C (e.g. Alloy 20) Temperature coefficient 780 ppm/K, 0...300 °C (e.g. Alloy L) Temperature coefficient 1100 ppm/K, 0...500 °C (e.g. Alloy A20) Temperature coefficient 780 ppm/K, 0...500 °C (e.g. Alloy L) Temperature coefficient 3500 ppm/K, 0...300 °C (e.g. NOREX)</p> <p>Please take the necessary setting from the ROPEX application report</p>

Analog output (actual value) Terminals 17+18	0...10 VDC, $I_{max} = 5 \text{ mA}$ Equivalent to 0...300 °C or 0...500 °C Accuracy: $\pm 1\%$ plus 50 mV
Alarm relay Terminals 12, 13, 14	$U_{max} = 30 \text{ V (DC/AC)}$, $I_{max} = 0.2 \text{ A}$, changeover contact, potential-free
Power loss	Max. 20 W
Ambient conditions	Max. altitude: 2000 m Ambient temperature: +5...+45 °C Max. relative humidity: 80% at temperatures up to +31 °C, decreasing linearly to 50% relative humidity at +45 °C
Degree of protection	IP20
UL file	E464680
Installation	<p>A minimum safety clearance of 20 mm all round (e.g. from other devices and wiring) must be allowed when installing the device.</p> <p>The moving clip required for fastening must be facing down for mounting on a horizontal top hat rail.</p> <p>End holders to mechanically fix the controller must be fitted at both ends for mounting on a vertical top hat rail.</p> 
Weight	Approx. 0.5 kg (incl. connector plug-in parts)
Housing material	Plastic, polycarbonate, UL-94-V0
Connecting cable Type / cross-sections	Rigid or flexible; 0.2...2.5 mm ² (AWG 24...12) plug-in connectors Plug-in connectors: Tightening torque: 0.5...0.6 Nm (screwdriver: SZS 0.6x3.5 mm)  If ferrules are used, they must be crimped in accordance with DIN 46228 and IEC / EN 60947-1. This is essential to ensure proper electrical contact in the terminals.

11 Dimensions

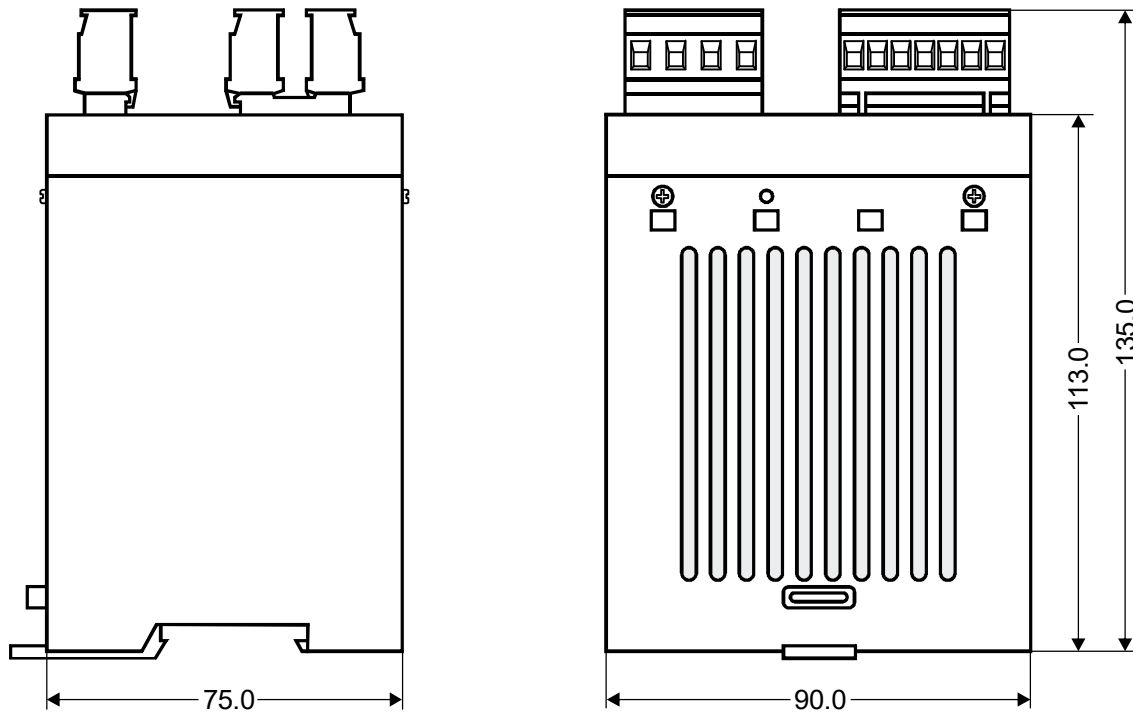

12 Modifications

12.1 Modifications (MODs)

Owing to its universal design, the RESISTRON[®] temperature controller RES-5011 is suitable for a very wide range of heatsealing applications.

One modification (MOD) is available for the RESISTRON[®] temperature controller RES-5011 for implementing special applications.

The modifications must be ordered separately.



MOD 01

Booster for low secondary voltages ($U_R = 0.2...60$ VAC). This modification is necessary, for example, for very short or low-resistance heatsealing bands.

13 How to order

Images exemplary

	<p>Controller RES-5011 Power supply 115...400 VAC, art. no. 7501100 Scope of supply: Controller includes connector plug-in parts (without current transformer)</p> <p>Modification MOD . . (optional, if required) For example → 01: MOD 01, art. no. 800001 (booster for low voltage)</p> <p>Please indicate the article numbers of the controller and the required modifications (optional) in all orders, e.g. RES-5011 + MOD 01 (controller with booster for low voltage) Order of art no. 7501100 + 800001</p>
	<p>Current transformer PEX-W5 Art. no. 885107</p>
	<p>Monitoring current transformer MSW-2 Art. no. 885212</p>
	<p>Network filter LF- → 06480: Continuous current 6 A, 480 VAC, art. no. 885500 (with UL certification) 10520: Continuous curr. 10 A, 520 VAC, art. no. 885504 (with UL and CSA certification) 35480: Continuous curr. 35 A, 480 VAC, art. no. 885506 50520: Continuous curr. 50 A, 520 VAC, art. no. 885509 (with UL and CSA certification)</p>
	<p>Impulse transformer</p> <p>For design and order specifications, see ROPEX application report Design in accordance with EN 61558 Available with UL certifications and thermal switch, if necessary. In addition, we can individually design and offer you an upstream transformer.</p>
	<p>Temperature meter ATR - . → 3: 300 °C range, art. no. 882130 5: 500 °C range, art. no. 882150</p>

	<p>Booster B- . . .</p> <p>→ 075415: Impulse loaded 75 A, 415 VAC, art. no. 885302 100400: Impulse loaded 100 A, 400 VAC, art. no. 885304</p>
	<p>Lines</p> <p>For design and order specifications, see ROPEX application report</p>

14 Index

Numbers

24VDC supply voltage 70

A

AA bit 26
Actual value 28
Actual value output 59
AC bit 24
AG bit 26
Alarm output 62
Alarm relay 17, 71
Alloy 16, 19
Altitude 71
AL bit 18, 26
Ambient conditions 71
Ambient temperature 71
Application Report 8, 11
AUTOCAL 7, 18
 Active 26
 Blocked 24, 26
 Starting 24
AUTOCOMP 50
Automatic phase angle compensation 50
Automatic zero calibration 18, 23
Automatic zeroing 7
AUTOTUNE 7
AUX interface 61

B

Booster 14, 74
Booster connection 60
Burning in (heatsealing band) 17, 19

C

Circuit-breaker 10
Control active 27
Current transformer 11, 73

D

Data format 50
Data memory 62
Date 62
Degree of protection 71
Device description file (EDS) 22
Dimensions 72
Disposal 6

E

EDS file 22
Error code format 50
Error diagnosis 7
Error messages 63
EtherCAT interface 70

Ethernet/IP interface 70
External switching amplifier 14

F

Factory settings 69
Fault 26
Fault areas 67
Fuse 10

H

Heatsealing band type 70
Heatup timeout 53

I

Impulse transformer 10, 73
Input data 23
Installation 8, 71
Installation procedure 8
Installation regulations 8

L

Line filter 5, 10, 11
Line frequency 70
Line voltage 70, 73

M

Maintenance 5, 69
Master AUTOCAL (MA) 25
Measurement interruption 23, 28
Measurement pause 25
Measuring impulse duration 50
Measuring range 70
Modification MOD 72, 73
Monitoring current transformer 73
MP bit 25
MSW-2 73
MU bit 28

N

Network filter 73
Network frequency 7

O

Output data 26
Over-current protection 10

P

PEX-W4/-W5 4, 11
PEX-W5 73
Phase angle compensation 50
Power loss 71
Power supply 10

Power supply system 70

R

RA bit 19, 27
Relative humidity 71
Replacement (heatsealing band) 17, 19
Reset 24
ROPEXvisual 61
RS bit 24

S

Set point 26
Standby mode 58
Start 24
Startup 15
ST bit 19
System diagnosis 61
System monitoring 62

T

TCR 4, 17
Temperature achieved 26
Temperature coefficient 4, 17
Temperature diagnosis 52, 53
Temperature meter 60, 73
Temperature OK 26

Temperature range 16, 70
Temperature regulation 6
TE bit 26
Thermal impulse process 6
Time 62
Timestamp 62
TO bit 26
Transformer 4, 10, 73
Transportation 6
Type of construction 69

U

UL file 71
Undervoltage detection 58
USB interface 61
Use 6

V

View of the device 15
Visualization software 61

W

WA bit 26
Web server 55
Wiring 8, 10
Wiring diagram 13, 14