

SK5

BLIND MATE WITH CLAMPING HUBS

0.1 – 850 Nm



PROPERTIES

MATERIAL

- ▶ **Bellows:** high grade stainless steel
- ▶ **Clutch system:** hardened steel
- ▶ **Clamping hubs:** up to size 80 aluminum, size 150 and up steel
- ▶ **Tapered male segment:** high strength plastic

DESIGN

Two clamping hubs with one clamping screw each, and one of the clamping hubs with tapered male segment

for plug-in installation. Clutch system: spring loaded ball-detent principle. Operable temperature range from -30 to +100° C.

AVAILABLE FUNCTION SYSTEMS

- ▶ **W = Single position / automatic re-engagement (standard)**
- ▶ **D = Multi-position / automatic re-engagement**
- ▶ **G = Load holding / load blocking**
- ▶ **F = Full disengagement / manual re-engagement**

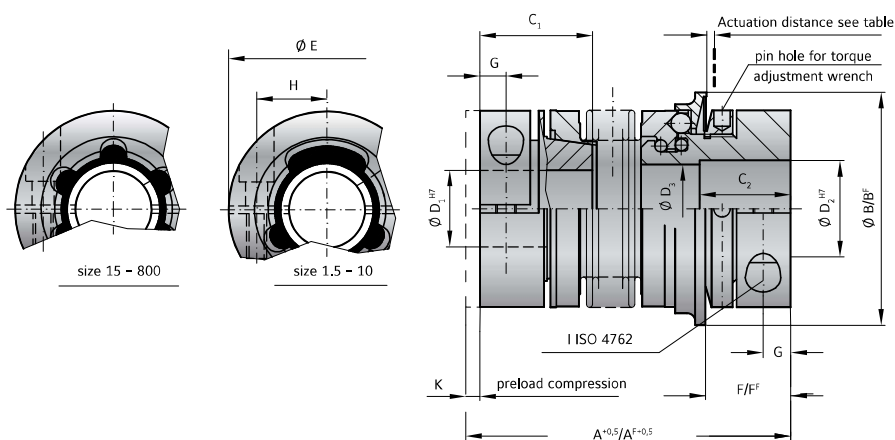

MODEL SK5

Size		1.5	2	4.5	10	15	30	60	80	150	300	500	800
Adjustment range available from - to (approx. values) (Nm)	T _{KN}	0.1-0.6 0.4-1 0.8-1.5	0.2-1.5 or 0.5-2	1-3 or 3-6	2-6 or 4-12	5-10 or 8-20	10-25 or 20-40	10-30 or 25-80	20-70 or 30-90	20-70 or 45-150	100-200 150-240 200-320	80-200 200-350 300-500	400-650 500-800 650-850
Adjustment range available from - to (approx. values) ("F" Version) (Nm)	T _{KN}	0.3-0.8 or 0.6-1.3	0.2-1 or 0.7-2	2.5-4.5	2-5 or 5-10	7-15	8-20 or 16-30	20-40 or 30-60	20-60 or 40-80	80-150	120-200 or 160-300	60-150 100-300 250-500	200-400 or 450-800
Overall length +0.5 (mm)	A	44	48 54	60 68	70 79	76 83	89 97	105 115	115 127	116 128	143 157	166 180	196
Overall length +0.5 ("F" Version) (mm)	A ^F	44	48 54	60 68	70 79	76 83	89 97	105 115	117 129	118 130	146 160	170 184	207
Actuation ring Ø (mm)	B	23	29	35	45	55	65	73	92	92	120	135	152
Actuation ring Ø ("F" Version) (mm)	B ^F	24	32	42	51.5	62	70	83	98	98	132	155	177
Clamping fit length C ₁ /C ₂ (mm)	C ₁ /C ₂	14 11	16 13	19 16	21 16	28 22	33 27	39 31	43 35	43 35	52 42	61 52	74 48
Bore Diameter from Ø to Ø H7 (mm)	D ₁	3-8*	4-12*	5-16*	5-20*	8-22*	10-25*	12-32	14-38*	14-38*	30-56	35-60	40-62*
Bore Diameter from Ø to Ø H7 (mm)	D ₂	3-8*	4-12*	5-14*	5-20*	8-26	10-30	12-32	14-42	14-42	30-60	35-60	40-75
Diameter (mm)	D ₃	9.1	12.1	14.1	20.1	21.1	24.1	32.1	36.1	36.1	58.1	60.1	60.1
Outside diameter (mm)	E	19	25	32	40	49	55	66	81	81	110	123	134
Distance (mm)	F	12	13	15	17	19	24	28	31	31	35	45	50
Distance ("F" Version) (mm)	F ^F	11.5	12	14	16	19	22	29	31	30	36	43	54
Distance (mm)	G	3.5	4	5	5	6.5	7.5	9.5	11	11	13	17	18
Distance between centers (mm)	H	6	8	10	15	17	19	23	27	27	39	41	2x48
Screw ISO 4762	I	M2.5	M3	M4	M4	M5	M6	M8	M10	M10	M12	M16	2xM16
Tightening torque (Nm)	I	1	2	4	4.5	8	15	40	50	70	130	200	250
Pretensioning, approx (mm)	K	0.1-0.5	0.2 - 0.7	0.2 - 0.7	0.2 - 1.0	0.2 - 1.0	0.3 - 1.5	0.5 - 1.5	0.5 - 1.0	0.5 - 1.0	0.5 - 1.5	0.5 - 2.0	0.8 - 2.0
Axial recovery of coupling max. (N)	K	4	8 5	15 10	25 30	20 12	50 30	70 45	48 32	82 52	157 106	140 96	200
Approx. weight (kg)		0.038	0.07	0.2	0.3	0.4	0.6	1.4	2	2.4	5.9	9.6	15
Moment of inertia (10 ⁻³ kgm ²)	J _{ges}	0.01	0.01 0.01	0.02 0.02	0.06 0.07	0.10 0.15	0.27 0.32	0.75 0.80	1.80 1.90	2.50 2.80	6.50 7.00	13.0 17.0	50
Torsional stiffness (10 ³ Nm/rad)	C _T	0.7	1.2 1.3	7 5	8 7	12 10	18 16	40 31	68 45	90 60	220 190	260 250	390
Lateral ± (mm)	max. values	0.15	0.15 0.20	0.20 0.25	0.20 0.30	0.15 0.20	0.20 0.25	0.20 0.25	0.20 0.25	0.20 0.25	0.25 0.30	0.30 0.35	0.35
Angular ± (Degree)	values	1	1 1.5	1.5 2	1.5 2	1 1.5	1 1.5	1 1.5	1 1.5	1 1.5	1.5 2	2 2.5	2.5
Lateral spring stiffness (N/mm)		70	40 30	290 45	280 145	475 137	900 270	1200 420	920 290	1550 435	3750 1050	2500 840	2000
Actuation distance (mm)		0.7	0.8	0.8	1.2	1.5	1.5	1.7	1.9	1.9	2.2	2.2	2.2

A^F, B^F, L^F = Full disengagement / manual re-engagement version (F)

* keyway with max. bore only conditionally possible.