

PROPERTIES

MATERIAL

- ▶ **Clutch system:** hardened steel
- ▶ **Clamping collar:** up to size 500 aluminum, size 800 and up steel

DESIGN

With clamping ring and one clamping screw. Clutch system: spring loaded ball-detent principle. Operable temperature range from -30 to +120° C.

AVAILABLE FUNCTION SYSTEMS

- ▶ W = Single position / automatic re-engagement (standard)
- ▶ D = Multi-position / automatic re-engagement
- ▶ G = Load holding / load blocking
- ▶ F = Full disengagement / manual re-engagement



STANDARD DESIGN | SIZE 15 - 1,500

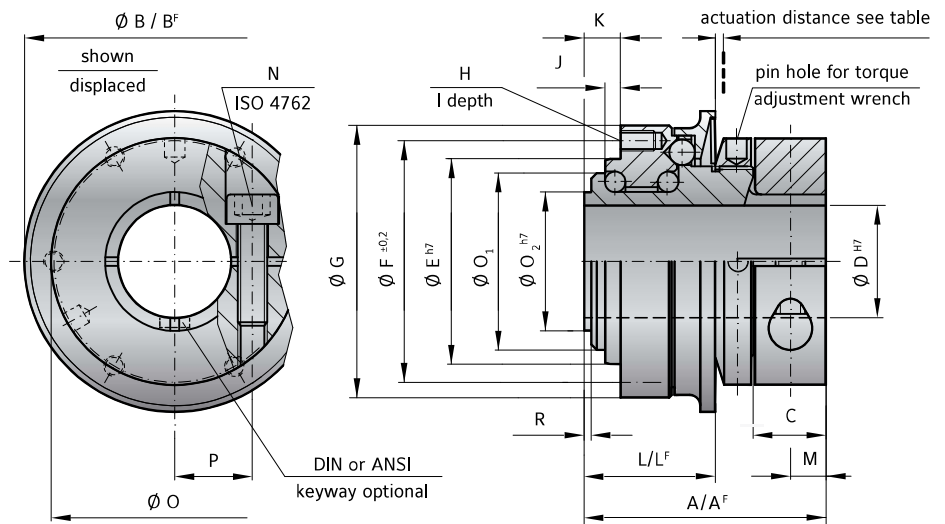

MODEL SKN

SIZE		15	30	60	150	200	300	500	800	1500
Adjustment range available from - to (approx. values)	(Nm) T _{KN}	5-10 or 8-20	10-25 or 20-40	10-30 or 25-80	20-70 45-150 80-180	30-90 60-160 120-240	100-200 150-240 200-320	80-200 200-350 300-500	400-650 500-800 600-850	600-800 700-1200 1000-1800
Adjustment range available from - to (approx. values) ("F" Version)	(Nm) T _{KN}	7-15	8-20 or 16-30	10-30 20-40 30-60	20-60 40-80 80-150	80-140 or 130-200	120-180 or 160-300	50-150 100-300 250-500	200-400 or 450-800	1000-1250 or 1250-1500
Overall length	(mm) A	47	59	65	71	80	84	101	115	145
Overall length, ("F" Version)	(mm) A ^F	47	59	65	73	83	87	107	126	160
Actuation ring Ø	(mm) B	55	65	73	92	99	120	135	152	174
Actuation ring Ø, ("F" Version)	(mm) B ^F	62	70	83	98	117	132	155	177	187
Clamping fit length	(mm) C	13.5	16	20	23	26	26	30	35	46
Inside diameter from Ø to Ø H7	(mm) D	12-22*	14-25.4*	16-32	19-40*	24-44	30-56*	35-60*	40-62*	50-72*
Pilot diameter h7	(mm) E	40	47	55	68	75	82	90	100	125
Bolt-hole circle diameter ± 0.2	(mm) F	47	54	63	78	85	98	110	120	148
Flange outside diameter -0.2	(mm) G	53	63	72	87	98	112	128	140	165
Thread	H	6xM4	6xM5	6xM5	6xM6	6xM6	6xM8	6xM8	6xM10	6xM12
Thread depth	(mm) I	6	8	9	10	10	10	12	15	16
Centering length -0.2	(mm) J	3	5	5	5	5	6	9	10	13.5
Distance	(mm) K	8	11	11	12	12	15	21	19	25
Distance	(mm) L	27	35	37	39	44	47	59	67	82
Distance, ("F" Version)	(mm) L ^F	27	37	39	41.5	47	51.5	68	75	94
Distance	M	6.5	7.5	9.5	11	13	13	14.5	18	22.5
Screw ISO 4762	N	M5	M6	M8	M10	M12	M12	M14	M16	M20
Tightening torque		8	15	40	70	120	130	210	270	500
Clamp ring Ø	O	49	55	67	85	94	110	121	134	157
Diameter	(mm) O ₁	35	42	49	62	67	75	84	91	112
Diameter h7	(mm) O ₂	27	36	39	50	55	65	72	75	92
Distance between centers	(mm) P	17.5	19	23.5	30	32.5	39	43.5	45	52
Distance	(mm) R	2.5	2.5	2.5	2.5	3	3	4	4	4.5
Moment of inertia (10 ⁻³ kgm ²)	J _{ges}	0.15	0.25	0.50	1.60	2.70	5.20	8.60	20	31.5
Approx. weight	(kg)	0.4	0.7	1.0	1.3	2.0	3.0	4.0	5.5	10
Actuation distance	(mm)	1.5	1.5	1.7	1.9	2.2	2.2	2.2	2.2	3.0

A^F, B^F, L^F = Full disengagement / manual re-engagement version (F)

* keyway with max. bore only in clamping hub possible.

ORDERING EXAMPLE	SKN	60	W	19.05	60	25-80	XX
Model	●						Special designation only (e.g. special bore / keyway dimensions).
Size		●					
Function system			●				
Bore D1 H7				●			
Disengagement torque Nm					●		
Torque adjustment range Nm						●	
For custom features place an XX at the end of the part number and describe the special requirements (e.g. SKN / 60 / W / 19.05 / 60 / 25-80 / XX; XX=stainless steel)							