

SLP

WITH KEYWAY CONNECTION

10 - 700 Nm



PROPERTIES

DESIGN
 With DIN 6885 or ANSI B17.1 keyway.
 Clutch system: spring loaded ball-detent principle. Operable temperature range from -30 to +120° C.

AVAILABLE FUNCTION SYSTEMS

- ▶ W = Single position / automatic re-engagement (standard)
- ▶ D = Multi-position / automatic re-engagement

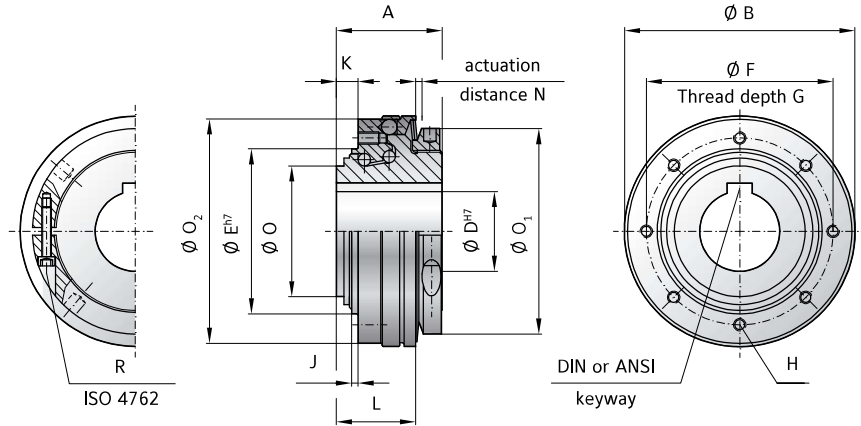

MODEL SLP

SIZE			30	60	150	300
Adjustment range* from - to	(Nm)	T _{KN}	10-35 30-80 40-135	30-80 60-120 100-200	40-100 100-200 150-300	200-350 300-450 400-550 550-700
Overall length	(mm)	A	30	35	41	48
Actuation ring diameter	(mm)	B	63	74	92	118
Bore diameter from Ø to Ø H7	(mm)	D	12-25.4 (28)*	16-30 (32)*	19-44 (46)*	22-54 (58)*
Pilot diameter h7	(mm)	E	43	53	68	85
Bolt-hole circle diameter ± 0.2	(mm)	F	48	60	75	95
Thread depth +1	(mm)	G	5	6	7	9
Fastening threads		H	8x M4	8x M4	8x M5	8x M6
Centering length -0.2	(mm)	J	2	2	3	3
Distance	(mm)	K	6	7	9	9
Distance to actuation ring edge	(mm)	L	23	26	32	36
Actuation distance	(mm)	N	1.3	1.5	1.8	2
Ø Base element	(mm)	O	35	42	54	70
Ø Adjustment nut	(mm)	O ₁	55	66	82	100
Ø Flange -0.2	(mm)	O ₂	58	72	87	110
Adjustment nut's clamp screw ISO 4762		R	M3	M3	M3	M4
Tightening torque	(Nm)		2	2	2	4.5
Approx. weight	(kg)		0.2	0.35	0.7	1.1
Approx. moment of inertia at D max.	(10 ⁻³ kgm ²)	J ₈₈₅	0.1	0.4	1.1	2.3

* maximum bore diameters shown are only available with shallow keyway according to DIN 6885/3 or special heights for inch bores

ORDERING EXAMPLE	SLN SLP	60	W	25.4	80	60-120	XX
Model	●						Special designation only (e.g. special bore / keyway dimensions).
Size		●					
Function system			●				
Bore D H7				●			
Disengagement torque Nm					●		
Torque adjustment range Nm						●	
For custom features place an XX at the end of the part number and describe the special requirements (e.g. SLN / 60 / W / 25.4 / 80 / 60-120; XX=special dual keyway)							