

STN

WITH CONICAL CLAMPING BUSHING

200 - 5,000 Nm



PROPERTIES

MATERIAL

Hardened steel (nitrocarburized surface)

DESIGN

► Drive side: coupling hub with conical clamping bushing connection (spline profile on request)

► Driven side: output flange with 12x fastening threads and integral bearings

► Safety elements: evenly spaced around the circumference; externally adjustable

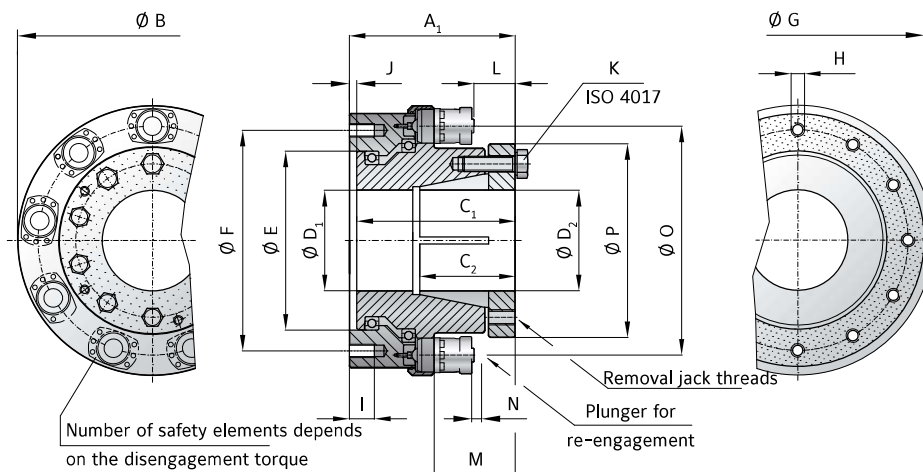

MODEL STN | SIZE 2 - 5

SIZE		2			5			
Adjustment range available from - to	(KNm)		0.2-0.5	0.5-1.0	1.0-1.5	0.7-2	1.2-4	3.2-5
			3×ST10	6×ST10	6×ST10	3×ST15	6×ST15	6×ST15
Overall length	(mm)	A ₁	124.5			160		
Flange outside diameter	(mm)	B	198			220		
Fit length / keyway length	(mm)	C ₁	118			155		
Effective clamping length	(mm)	C ₂	45			82		
Bore diameter possible Ø to Ø F7	(mm)	D ₂	45-70			40-80		
Bore diameter max. Ø F7 with keyway	(mm)	D ₂	60			70		
Flange centering diameter H7	(mm)	E	132			145		
Bolt circle diameter ±0.3	(mm)	F	162			170		
Outside diameter h7	(mm)	G	192			209		
Fastening threads	(mm)	H	12×M10			12×M12		
Thread depth	(mm)	I	15			20		
Fit length	(mm)	J	3			4		
Tightening screw ISO 4017		K	6×M10			6×M10		
Tightening torque	(Nm)		59			59		
Distance	(mm)	L	18			26.5		
Distance	(mm)	M	56			76.5		
Actuation path	(mm)	N	3.5			4.5		
Mounting diameter - elements	(mm)	O	154			170		
Hub outside diameter	(mm)	P	119			136		
Moment of inertia (approx.) D max. + max. sgmnt	(10 ⁻³ kgm ²)		77			151		
Speed max.	(rpm)		7000			6000		
Allowable max. radial force standard*	(KN)		5			10		
Approx. weight at D max. + max. sgmnt	(kg)		15			24		

* larger radial loads possible with special bearings

STN

WITH CONICAL CLAMPING RING

2,000 – 165,000 Nm



PROPERTIES

MATERIAL

Hardened steel (nitrocarburized surface)

► Driven side: output flange with 12x fastening threads and integral bearings

DESIGN

► Drive side: coupling hub with conical clamping ring connection (spline profile on request)

► Safety elements: evenly spaced around the circumference; externally adjustable

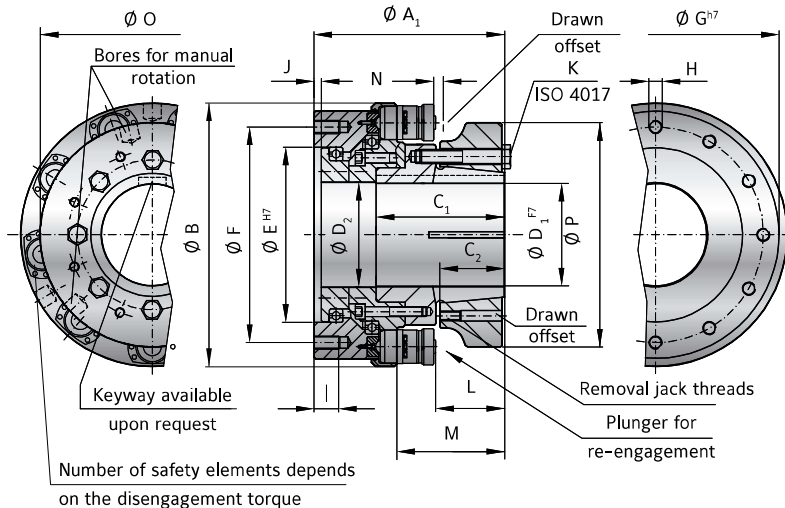

SAFETY COUPLINGS
ST

MODEL STN | SIZE 10 - 160

SIZE		10			25			40			60			160		
Adjustment range available from - to (KNm)		2-5	4-10	6-14	6-12	9-18	15-25	12-21	22-32	32-45	11-18	22-36	30-55	25-55	50-110	80-165
		3xST15	6xST15	9xST15	6xST15	9xST15	12xST15	6xST30	6xST30	9xST30	3xST30	6xST30	9xST30	3xST70	6xST70	9xST70
Overall length (mm)	A ₁	210			227			286			318			425		
Flange outside diameter (mm)	B	270			318			428			459			648		
Fit length / keyway length (mm)	C ₁	147			152			191			218			305		
Effective clamping length (mm)	C ₂	62			67			93.5			93			125		
Bore diameter possible Ø to Ø F7 (mm)	D ₁	65-110			70-150			110-170			80-200			140-290		
Bore diameter max. Ø F7 with keyway (mm)	D ₁	100			140			160			180			270		
Flange centering diameter H7 (mm)	E	170			210			270			300			450		
Bolt circle diameter ±0.3 (mm)	F	220			260			330			360			570		
Outside diameter h7 (mm)	G	259			298			380			418			618		
Fastening threads (mm)	H	12xM16			12xM16			12xM20			12xM20			12xM24		
Thread depth (mm)	I	25			30			36			35			40		
Fit length (mm)	J	6			8			9			8			11		
Tightening screw ISO 4017	K	8xM16			9xM16			11xM16			8xM20			8xM24		
Tightening torque (Nm)		180			180			180			570			710		
Distance (mm)	L	72			80			82.5			94			151		
Distance (mm)	M	122			127			151			163			240		
Actuation path (mm)	N	4			4			8			7.5			10		
Mounting diameter - elements (mm)	O	220			270			350			376			532		
Hub outside diameter (mm)	P	218			278			322			378			535		
Moment of inertia (approx.) D max. + max. sgmnt (10 ⁻³ kgm ²)		446			789			3570			5700			30700		
Speed max. (rpm)		4200			3800			3000			2500			2000		
Allowable max. radial force standard* (KN)		20			30			40			50			100		
Approx. weight at D max. + max. sgmnt (kg)		50			65			166			200			550		

* larger radial loads possible with special bearings