

4.30 Boschert-Chuck A50



A50 STO

Boschert automatic chuck, foot mounted without shaft end

A50 STW

Boschert automatic chuck, foot mounted with shaft end



A50 FLO

Boschert automatic chuck, flange mounted without shaft end

A50 FLW

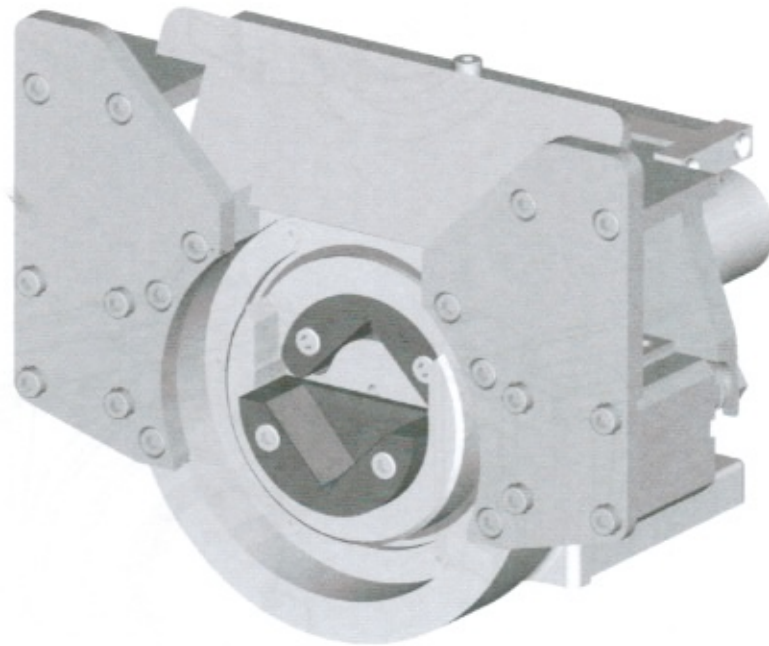
Boschert automatic chuck, flange mounted with shaft end

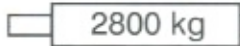

Standard Square bar:  50 mm (1.9658")
max. Beam weight:  2800 kg (6170 lbs)
max. torque:  1100 Nm (800 ft/lb)

Please note:

This chuck is a direct retrofit for the chuck 40-50 type C or 40-50 type VT.

		Info
Type:	VT	4.44
Journal shaft type VT:	VT2	4.33
Shaft end:	standard	4.33
Options:	proximity sensor	4.33
Add. parts:	brakes	6.00
	clutches	7.00

Boschert-Chuck A50 foot mounted



Boschert-Chuck A50

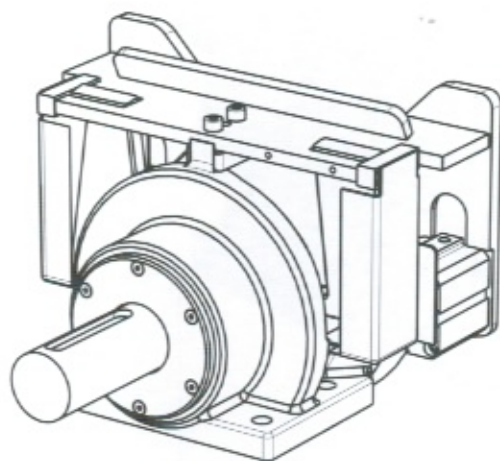
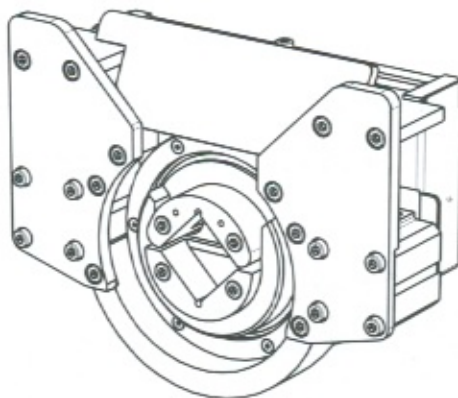

STW A50
chuck with shaft end

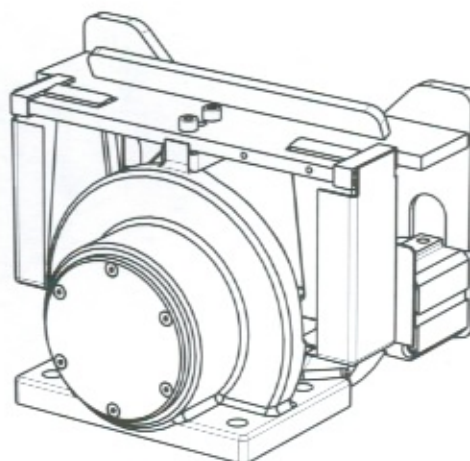

STO A50
chuck without shaft end

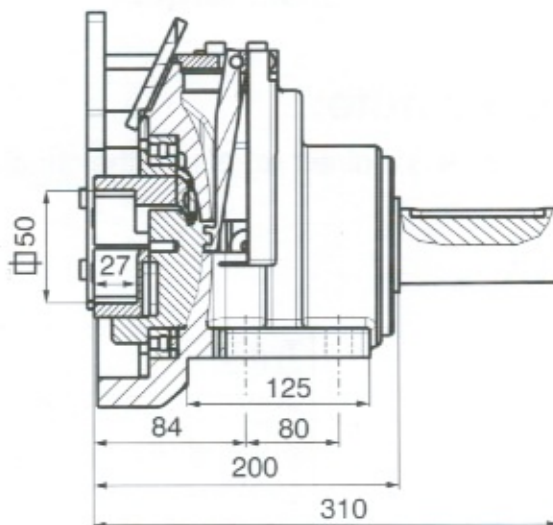
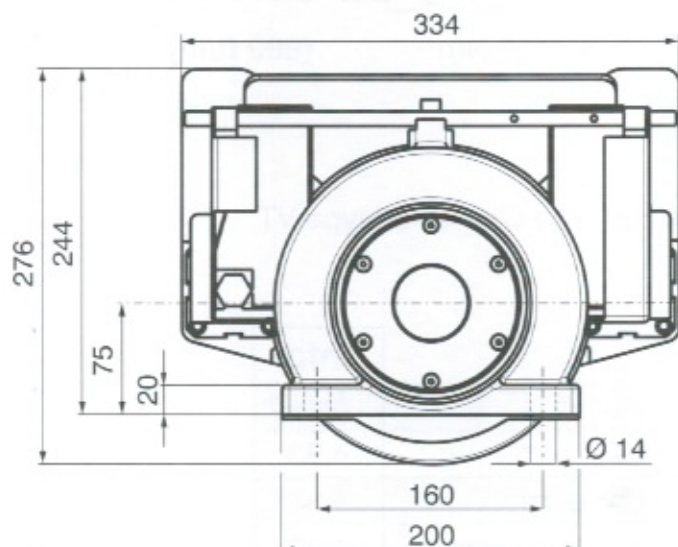

Shaft end details page 4.33

Boschert-Chuck A50 flange mounted



Boschert-Chuck A50

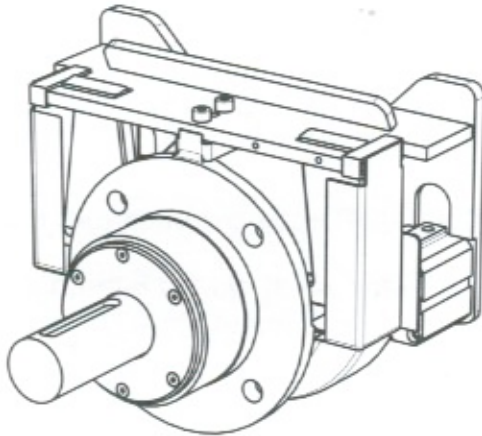
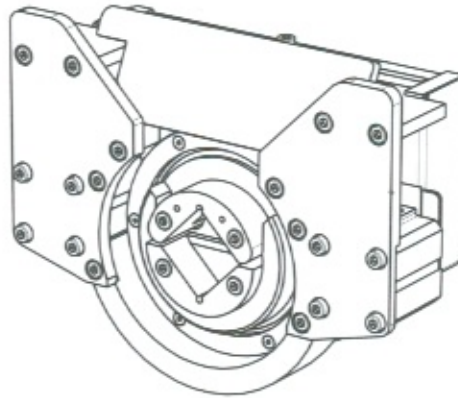

FLW A50
chuck with shaft end

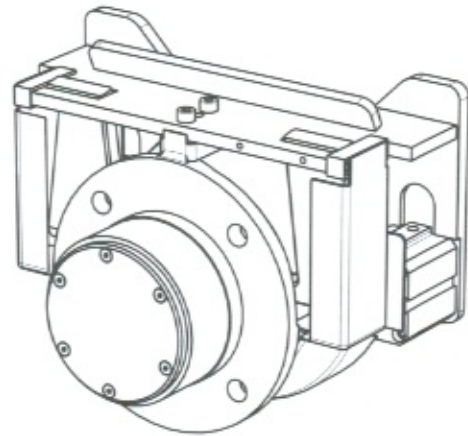

FLO A50
chuck without shaft end

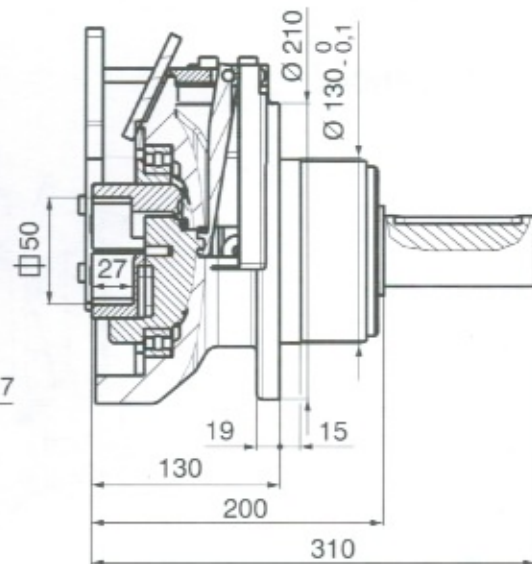
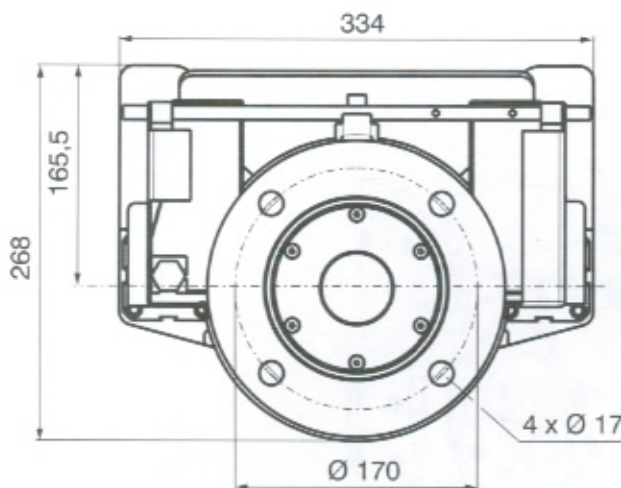

Shaft end details page 4.33

Boschert-Chuck A50 options

Journal shaft type



VT 2

Info: 11.10

Shaft end

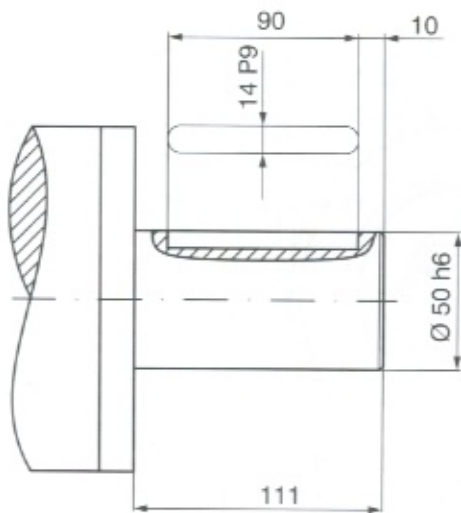

Standard shaft end

Special shaft ends per customer request

Max. shaft-dia.: Ø 50 mm
(without stop)

Proximity sensor

