

W22Xd - Flameproof Motors

Ex d | Ex d e

Medium and High Voltage

- Rib-cooled
- Tube-cooled

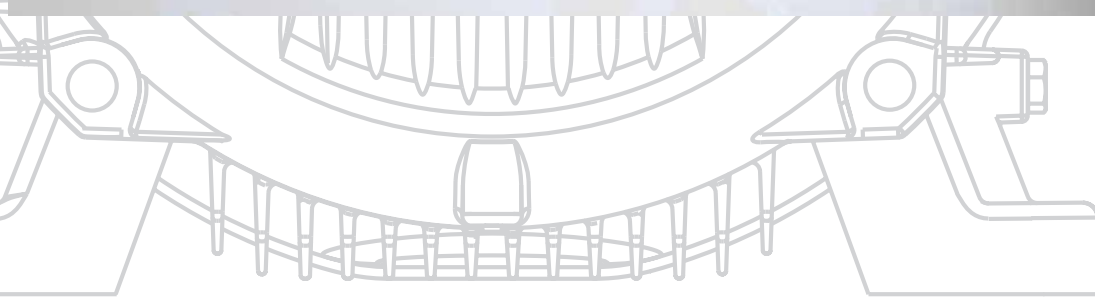
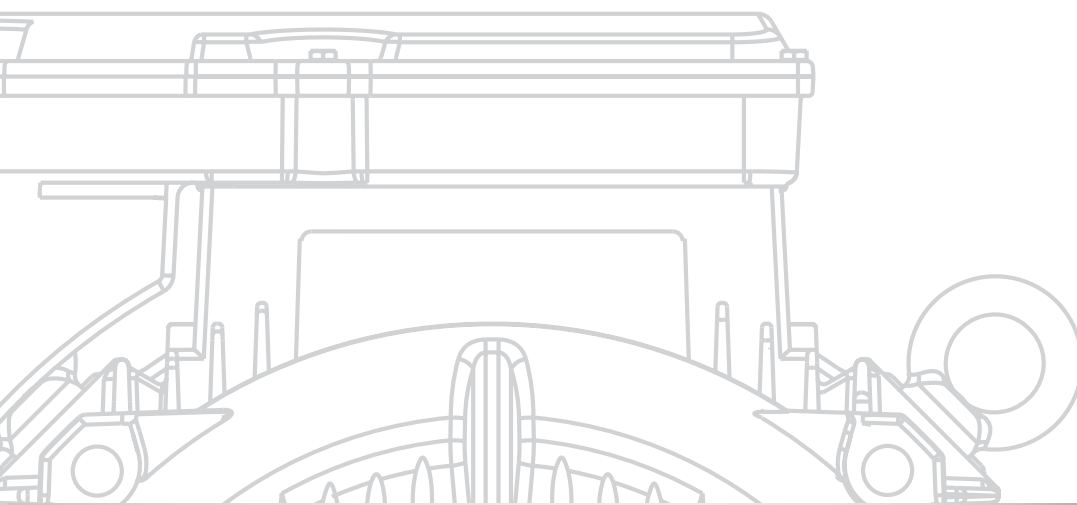



From **Gas Pipelines** in the harshness of the **Arctic Circle** conditions,
to **Oil rigs** on the hottest spots of the blustery **Arabian Desert**...



Summary

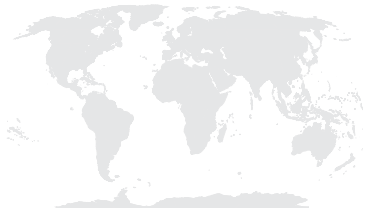

Standards and General Information

1

Product Information

17

Mechanical Features

27

Electrical Features

59

Standard and Optional Features

77

Electrical and Mechanical Data

95

Terminal Boxes

145

Additional Information

169

Standards and General Information

| | |
|---|-----------|
| 1.1. Explosive Atmospheres | 3 |
| 1.2. Standards and Classification of Explosive Atmospheres | 3 |
| 1.3. Equipment Type of Protection and Selection | 8 |
| 1.4. General Standards | 12 |
| 1.5. North American Standards and Regulations | 12 |

1. Standards and General Information

1.1. Explosive Atmospheres

A potentially explosive atmosphere is composed of air with mixtures of gases, vapours, mists or dusts, which might be ignited under certain operating conditions.

Equipment and protective systems intended for use in potentially explosive atmospheres cover a quite large range of products, including equipment used on fixed offshore platforms, in petrochemical plants, mines, flour mills and other areas where a potentially explosive atmosphere may arise.

WEG has a long experience in the design and manufacturing of motors which fully comply with the ATEX Directive 94/9/EC and the IECEx Scheme for Equipment Certification Program.

Optionally WEG flameproof motors can also comply with North American Standards and Regulations.

WEG motors are manufactured to meet special application requirements and severe duties in Hazardous Areas.





1.2. Standards and Classification of Explosive Atmospheres

1.2.1. ATEX Directives

The ATEX Directives were adopted by the European Union (UE) to simplify the free trade between the member states by aligning the technical and legal requirements for products intended for use in potentially explosive atmospheres.

There are two main Directives, sharing the responsibilities between the Manufacturer and the End User:

- The ATEX Manufacturers Directive 94/9/EC, also known as ATEX 95, places the responsibilities on the manufacturers: it specifies the Essential Health and Safety Requirements that must be met by the equipment intended to be used in potentially explosive atmospheres. In order to meet the ATEX Directive, products must comply with the Essential Requirements of this Directive and follow a Conformity Assessment Procedure. This assessment procedure involves obtaining the EC Type Examination certificate for products (requires the involvement of a Notified Body except for category 3 products), the Production Quality Assurance (assessed by a Notified Body that issues the QAN - Quality Assessment Notification according with ISO/IEC 80079-34 and periodically makes the audits) and an internal control of production (where the manufacturer carries out the necessary work to guarantee that the products are in compliance with the ATEX Directive). The ATEX product markings can be easily recognized by the symbol  that indicates the explosion protection and by the  mark that certifies the conformity with this Directive.

- The need to reduce the incidence of explosions and flash fires at work is prompted by both humanitarian and economic considerations and has led to the adoption by the European Parliament and the Council of the ATEX Directive 1999/92/EC, also known as ATEX 137, that lays down the minimum requirements for improving the safety and health protection of workers potentially at risk from explosive atmospheres. The humanitarian considerations are obvious: explosions and fires can cause severe injuries and deaths. The economic considerations are contained in every study into the true costs of accidents, which all show that improved risk management (health and safety) can substantially increase company profits. This latter is particularly true where potential explosions are concerned. The Directive 1999/92/EC classifies the environment into zones and outlines which category of equipment can be used in each zone. This Directive concentrates on the duties of the End User whose responsibilities are mainly:
 - The assessment of risks;
 - Preparation of an Explosion Protection Document;
 - The provision of suitable warning signs for areas where explosive atmospheres may occur.

The safety of an installation in a Hazardous Area is the result of co-operation between the equipment manufacturer, the installer and the end user. The ATEX Directives define Equipment Category, Zone and Group as follows:

| Equipment intended for use in mines Group I | | |
|--|---|---|
| Level of safety | Remain functional, even in the event of rare incidents related to equipment with an explosive atmosphere present. | Intended to be de-energized in the event of an explosive atmosphere |
| Equipment category | M1 | M2 |

Table 1.01 - Group I equipment

| Equipment intended for use in surface industry Group II | | | | | | |
|--|----------------|-----------|----------------------|-----------|--|-----------|
| Zone | 0 | 20 | 1 | 21 | 2 | 22 |
| Type of explosive atmosphere | G Gas | D Dust | G Gas | D Dust | G Gas | D Dust |
| Likelihood of an explosive atmosphere | Always present | | Occasionally present | | Infrequently and only for a short period | |
| Equipment category | 1 | | 2 | | 3 | |

Table 1.02 - Group II equipment

1.2.2. IECEx System

The objective of the IECEx System is to facilitate international trade in equipment and services for use in explosive atmospheres, while maintaining the required level of safety. IECEx System is accepted in many countries and aims to be the world approval system for electrical equipment to be installed in potentially explosive atmospheres.

The IECEx System is based on the use of International Standards, such as IEC. These Standards are dedicated to the highly specialized fields associated with the use of equipment, named Ex equipment, and installations in areas where a potential risk of fire or explosion may exist.

The administration of the IECEx System is governed by the IECEx Rules which are available for free in the IECEx website (www.iecex.com). Operational Documents supplement the Rules of Procedure and are for use within the IECEx System and Schemes.

The IECEx International Certification System comprises four different Schemes:

- IECEx Certified Equipment Scheme;
- IECEx Certified Service Facilities Scheme;
- IECEx Conformity Mark Licensing System;
- IECEx Certified Persons Scheme.

WEG has obtained the certification of the W22Xd range within the IECEx Certified Equipment Scheme and IECEx Conformity Mark Licensing System.

The IECEx Certified Equipment Scheme

To obtain IECEx Product Certification it is mandatory to involve an ExCB (IECEx Approved Certification Body) to test the products and samples according to the IEC Standards and issue the ExTR (IECEx Test Report).

It is also mandatory to comply with the Quality Management System (that must be previously assessed and in conformity with ISO 9001).

The QAR (IECEx Quality Assessment Report) is a document that presents the results of an on-site assessment of a manufacturer's quality management system by an ExCB, to the requirements of the IECEx Certified Equipment Scheme, more specific within the ISO/IEC 80079-34.

Upon satisfactory completion of the work, the issuing ExCB shall review and endorse the ExTR and QAR summary report at the IECEx website (www.iecex.com).

If the review is satisfactory and where the application includes a request to issue an IECEx CoC (Certificate of Conformity), the IECEx CoC shall be issued by the ExCB, in accordance with the relevant IECEx Operational Document. The manufacturer and the ExCB shall each retain a set of the documentation referred to in the certificate, including ExTR and manufacturer's documentation. ExTRs and/or QARs may be issued on their own without the issuing of an IECEx CoC.

The preservation of IECEx Certificate of Conformity is assured by the ExCB. For that the ExCB shall:

- Conduct of surveillance assessments/audits is covered by the QAR process;
- Respond to public inquiries regarding the certificate;
- Take the necessary action when aware of possible breaches by the applicant, e.g. product not subject to IECEx Certificate of Conformity is being claimed as "IECEx Certified".

The IECEx Conformity Mark Licensing System

The IECEx Conformity Mark, when appearing on or in relation to an Ex Product, indicates that the Ex Product is covered by an IECEx Certificate of Conformity which in turn is listed under the scope of the IECEx Conformity Mark License.

To users and consumers the Mark demonstrates the compliance with the requirements of the relevant IEC Standard(s) without any national differences and/or Essential Differences in Requirements and with other IECEx recognized normative documents, approved by the IECEx Management Committee.

The IECEx Conformity Mark significantly improves WEG's capability to trade its products globally.

Benefits for the customer

WEG IECEx certified motors are easy to identify because they have the IECEx certificate number on their nameplate and an IECEx Conformity Mark plate with the following design:

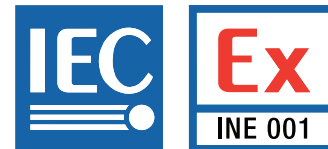

Figure 1.01 - IECEx conformity mark

The IECEx certificates are issued electronically and are all available on the IECEx website. The access is public and they are printable. Please check WEG's certificates on IECEx website (www.iecex.com).

1.2.3. Applicable IEC/EN Standards

The implementation of ATEX Directives and IECEx Scheme are supported by the EN (CENELEC) and IEC Standards respectively, regarding the enclosure protections of electric motors to be used in potentially explosive atmospheres, as well as the hazardous areas classification criteria, depending on the presence of Gas and/or Combustible Dusts.

Table 1.03 below, lists the main applicable IEC/EN Standards for the manufacturing of flameproof motors.

| | |
|-------------------|--|
| IEC/EN 60079-0 | Explosive atmospheres Part 0: Equipment - General requirements |
| IEC/EN 60079-1 | Explosive atmospheres Part 1: Equipment protection by flameproof enclosures "d" |
| IEC/EN 60079-7 | Explosive atmospheres Part 7: Equipment protection by increased safety "e" |
| IEC/EN 60079-10-1 | Explosive atmospheres Part 10-1: Classification of areas - Explosive gas atmospheres |
| IEC/EN 60079-10-2 | Explosive atmospheres Part 10-2: Classification of areas - Combustible dust atmospheres |
| IEC/EN 60079-31 | Explosive atmospheres Part 31: Equipment dust ignition protection by enclosure "t" |
| IEC/EN 60079-14 | Explosive atmospheres Part 14: Electrical installations design, selection and erection |
| IEC/EN 60079-17 | Explosive atmospheres Part 17: Electrical installations inspection and maintenance |
| IEC/EN 60079-19 | Explosive atmospheres Part 19: Equipment repair, overhaul and reclamation |

Table 1.03 - Applicable Standards

1.2.4. Zone Classification

The definition of areas according to the presence of an explosive atmosphere is set up in the following Standards:

- IEC/EN 60079-10-1: Explosive atmospheres - Part 10-1: Classification of areas - Explosive gas atmospheres;
- IEC/EN 60079-10-2: Explosive atmospheres - Part 10-2: Classification of areas - Combustible dust atmospheres.

Hazardous areas are classified into zones based upon the frequency of the occurrence and duration of an explosive atmosphere:

| Explosive gas atmospheres | |
|---------------------------|---|
| Zone 0 | An area in which an explosive atmosphere is present continuously or for long periods or frequently. |
| Zone 1 | An area in which an explosive atmosphere is likely to occur in normal operation occasionally. |
| Zone 2 | An area in which an explosive atmosphere is likely to occur in normal operation but, if it does occur, will persist for a short period. |

Table 1.04 - Zones classification for gas atmospheres

IEC / EN 60079-10-1 Classification of Hazardous Areas Explosive Gas Atmospheres

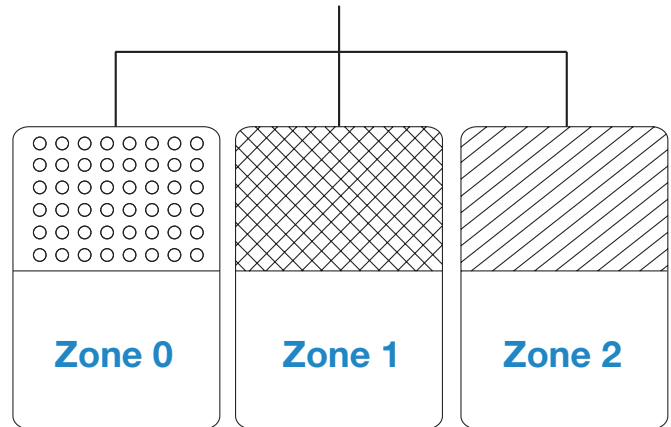

Figure 1.02 - Identification marks for gas atmospheres

| Combustible dust atmospheres | |
|------------------------------|---|
| Zone 20 | A place in which an explosive dust atmosphere, in the form of a cloud of dust in air, is present continuously, or for long periods or frequently. |
| Zone 21 | A place in which an explosive dust atmosphere, in the form of a cloud of dust in air, is likely to occur in normal operation occasionally. |
| Zone 22 | A place in which an explosive dust atmosphere, in the form of a cloud of dust in air, is not likely to occur in normal operation but, if it does occur, will persist for a short period only. |

Table 1.05 - Zones classification for dust atmospheres

IEC / EN 60079-10-2 Classification of Hazardous Areas Combustible Dust Atmospheres

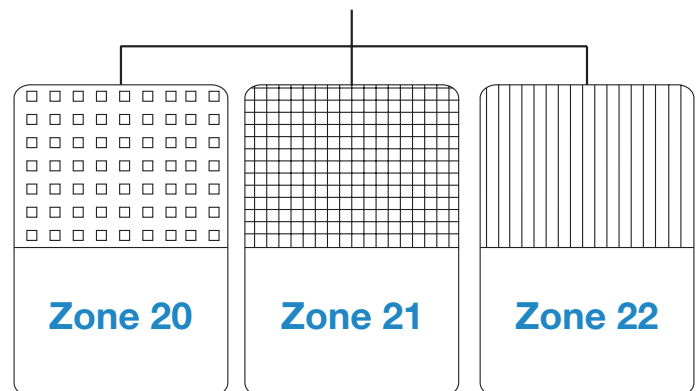

Figure 1.03 - Identification marks for dust atmospheres

The hazards presented by dusts are as follows:

- The formation of a dust cloud from any source of release, including a layer or accumulation, to form an explosive dust atmosphere;

- The formation of dust layers, which are not likely to form a dust cloud, but might ignite due to self-heating or exposure to hot surfaces or thermal flux and cause a fire hazard or over-heating of equipment. The ignited layer may also act as an ignition source for an explosive atmosphere.

For dust layers, the nature of housekeeping assures an essential control to their thickness. For a “good” level of housekeeping, dust layers are kept to negligible thickness and the consequent risks (occurrence of explosive dust clouds from layers and fire due to layers) have been removed.

It is rarely possible with a simple examination of a plant or its design to decide which parts of the plant can be identified according to the three zone definitions. A more detailed approach is therefore necessary and this involves the analysis of the basic possibility of an explosive atmosphere occurring.

Subsequent to the completion of the area classification, a risk assessment may be carried out to evaluate whether the consequences of ignition of an explosive atmosphere requires the use of a higher Equipment Protection Level (EPL) or may justify the use of lower equipment protection level than normally required. The EPL requirements may be recorded, as appropriate, on the area classification documents and drawings to allow proper selection of equipment.

1.2.5. Equipment Group and Equipment Protection Level (EPL)

A risk assessment approach for the acceptance of Ex equipment has been introduced in IEC/EN 60079-0 Standard as an alternative method to the current prescriptive and relatively inflexible approach linking equipment to zones. To facilitate this, a system of equipment protection levels has been introduced to clearly indicate the inherent ignition risk of equipment, no matter what type of protection is used.

The designation system of these equipment protection levels is as follows:

| Group | EPL | Designation |
|--|-----|---|
| I Electrical equipment intended for use in mines susceptible to firedamp. | Ma | Equipment for installation in a coalmine susceptible to firedamp, having a ‘very high’ level of protection, which has sufficient security that it is unlikely to become an ignition source in normal operation, during expected malfunctions or during rare malfunctions, even when left energized in the presence of an outbreak of gas. |

| Group | EPL | Designation |
|--|-----|--|
| I Electrical equipment intended for use in mines susceptible to firedamp. | Mb | Equipment for installation in a coal mine susceptible to firedamp, having a ‘high’ level of protection, which has sufficient security that it is unlikely to become a source of ignition in normal operation or during expected malfunctions in the time span between there being an outbreak of gas and the equipment being de-energized. |

Table 1.06 - Equipment Protection Levels (EPL's) for Group I

| Group | EPL | Designation |
|---|-----|--|
| II Electrical equipment intended for use in places with an explosive gas atmosphere other than mines susceptible to firedamp. The Group II is subdivided according to the nature of the explosive gas for which it is intended: <ul style="list-style-type: none"> • IIA for propane as the typical gas • IIB for ethylene as the typical gas • IIC for hydrogen as the typical gas | Ga | Equipment for explosive gas atmospheres, having a ‘very high’ level of protection, which is not a source of ignition in normal operation, during expected malfunctions or during rare malfunctions. |
| | Gb | Equipment for explosive gas atmospheres, having a ‘high’ level of protection, which is not a source of ignition in normal operation or during expected malfunctions |
| | Gc | Equipment for explosive gas atmospheres, having an ‘enhanced’ level of protection, which is not a source of ignition in normal operation and which may have some additional protection to ensure that it remains inactive as an ignition source in the case of regular expected occurrences (for example failure of a lamp). |

Table 1.07 - Equipment Protection Levels (EPL's) for Group II

| Group | EPL | Designation |
|--|-----|---|
| III Electrical equipment intended for use in places with an explosive dust atmosphere other than mines susceptible to firedamp. The Group III is subdivided according to the nature of the explosive dust for which it is intended: <ul style="list-style-type: none"> • IIIA: combustible flyings • IIIB: non-conductive dust • IIIC: conductive dust | Da | Equipment for combustible dust atmospheres, having a ‘very high’ level of protection, which is not a source of ignition in normal operation, during expected malfunctions, or during rare malfunctions. |
| | Db | Equipment for combustible dust atmospheres, having a ‘high’ level of protection, which is not a source of ignition in normal operation or during expected malfunctions. |

| Group | EPL | Designation |
|---|-----|---|
| III Electrical equipment intended for use in places with an explosive dust atmosphere other than mines susceptible to firedamp. The Group III is subdivided according to the nature of the explosive dust for which it is intended: <ul style="list-style-type: none"> • IIIA: combustible flyings • IIIB: non-conductive dust • IIIC: conductive dust | Dc | Equipment for combustible dust atmospheres, having an 'enhanced' level of protection, which is not a source of ignition in normal operation and which may have some additional protection to ensure that it remains inactive as an ignition source in the case of regular expected occurrences (for example failure of a lamp). |

Table 1.08 - Equipment Protection Levels (EPL's) for Group III

The various levels of protection of equipment must be capable of functioning in conformity with the operational parameters established by the manufacturer to that level of protection.

| Protection afforded | Equipment protection level | Performance of protection | Conditions of operation |
|---------------------|----------------------------|---|--|
| | Group | | |
| High | Db | Suitable for normal operation and frequently occurring disturbances or equipment where malfunctions are normally taken into account | Equipment remains functioning in zones 21 and 22 |
| | Group III | | |
| Enhanced | Gc | Suitable for normal operation | Equipment remains functioning in zone 2 |
| | Group II | | |
| Enhanced | Dc | Suitable for normal operation | Equipment remains functioning in zone 22 |
| | Group III | | |

Table 1.09 - EPL's vs Operation conditions

1.2.6. Surface Temperature

IEC/EN 60079-0 Standard defines the limits for electrical equipment surface temperature for Groups I, II and III.

Group I electrical equipment

For electrical equipment of Group I, the maximum surface temperature shall not exceed:

- 150 °C on any surface where coal dust can form a layer;
- 450 °C where coal dust is not likely to form a layer (i.e., inside of a dust protected enclosure).

Group II electrical equipment

The maximum surface temperature determined shall not exceed:

- The temperature class assigned (see table below), or
- The maximum surface temperature assigned, or
- If appropriate, the ignition temperature of the specific gas for which it is intended.

| Temperature class for Group II electrical equipment | Maximum surface temperature °C |
|---|--------------------------------|
| T1 | 450 |
| T2 | 300 |
| T3 | 200 |
| T4 | 135 |
| T5 | 100 |
| T6 | 85 |

Table 1.10 - Temperature classes for Group II

| Protection afforded | Equipment protection level | Performance of protection | Conditions of operation |
|---------------------|----------------------------|---|---|
| | Group | | |
| Very high | Ma | Two independent means of protection or safe even when two malfunctions occur independently of each other | Equipment remains functioning when explosive atmosphere present |
| | Group I | | |
| Very high | Ga | Two independent means of protection or safe even when two malfunctions occur independently of each other | Equipment remains functioning in zones 0, 1 and 2 |
| | Group II | | |
| Very high | Da | Two independent means of protection or safe even when two malfunctions occur independently of each other | Equipment remains functioning in zones 20, 21 and 22 |
| | Group III | | |
| High | Mb | Suitable for normal operation and severe operating conditions | Equipment de-energized when explosive atmosphere present |
| | Group I | | |
| High | Gb | Suitable for normal operation and frequently occurring disturbances or equipment where malfunctions are normally taken into account | Equipment remains functioning in zones 1 and 2 |
| | Group II | | |

Group III electrical equipment

- Maximum surface temperature determined without a dust layer shall not exceed:
 - The maximum surface temperature class assigned;
 - The layer or cloud ignition temperature of the specific combustible dust for which it is intended.
- Maximum surface temperature with respect to dust layers:
 - The maximum surface temperature may also be determined for a given depth of layer, TL, of dust surrounding all sides of the apparatus, unless otherwise specified in the documentation, and marked with the symbol “X” to indicate this specific condition of use.

1.3. Equipment Type of Protection and Selection

1.3.1. TYPE Ex d – Flameproof Enclosure

(According to IEC/EN 60079-1 Standard)

It is a type of protection where the parts that can ignite an explosive atmosphere are in enclosures which are capable to withstand a pressure during an internal explosion of an explosive mixture. These enclosures are built to avoid the spreading of the internal combustion to the outside explosive atmosphere. An induction electric motor (of any protection) is not totally sealed, that is, air flows in and out.

While the motor is in operation, it heats up and the internal air gets to a higher pressure compared to the external pressure (air is blown out); when motor is switched-off, the internal pressure decreases, allowing in this way the entrance of air (which in this case is contaminated). The motor surfaces do not need to be totally enclosed to avoid flame propagation. The minimum opening required to avoid passage of flames depends on the gas or vapour that is present.

Therefore, there will always be flame passages through the motor enclosure. The safety level on an explosion proof motor is on the fact that it must ensure that all flame passages never exceed the standardized dimensions and that the motor is physically suitable to withstand an internal explosion without transmitting it to the external environment.

Ex d protection will not allow that an internal explosion propagates to the external environment. To ensure safety to the system, WEG provides a control of the openings and the finishing of joints once these are responsible for the volume of gases exchanged between inside and outside of the motor.

Flame propagation between motor interior and external atmosphere is guaranteed by constructive joints and gaps.

Internal pressure that can result of an explosion in the interior of the motor is guaranteed by the enclosure resistance (frame, endshields, internal bearing covers, terminal boxes and some adaptors).

The main characteristics of Ex d motors are as follows:

- Reinforced frame, terminal box and endshields;
- Wider contact surface (interference) between motor components;
- Reduced clearance between motor shaft and bearing cap to avoid transmission of sparks to the external environment;
- All components (frames, endshields, terminal box and terminal box lids) are submitted to overpressure test in factory or have a safety factor assessed by the Notified Body that exempts this need;
- Guarantee of external surface temperature of the motor in accordance with the correspondent Class of Temperature (e.g. T4 - 135 °C). The tests on WEG prototypes include a full evaluation of the external surface temperatures with motor supplied with electrical limit conditions.

Applications:

- Environments containing flammable gas or vapour continuously, intermittently or periodically in enough amounts to originate explosive or flammable mixtures arising out of repairs or maintenance services;
- The locations defined as Zones 1 and 2, Groups IIA, IIB and IIC are those where the following gases are found present: oil, naphtha, benzene, ammonia, propane, diethyl ether, acetone, alcohol, industrial methane, natural gas, as well as hydrogen and acetylene;
- Pumps, fans, blowers, crushers, conveyor systems, mills, cranes and other applications located in areas that require flameproof motors.

1.3.2 TYPE Ex d e – Flameproof Motors with Increased Safety Terminal Box

(According to IEC/EN 60079-1 and IEC/EN 60079-7 Standards)

WEG Ex d e motors differ from Ex d motors mainly on the configuration of terminals and terminal box. The terminal box with increased safety terminals prevents against any ignition source that may occur such as sparks, excessive heating, etc. Motors with flameproof enclosures “d” with Increased Safety terminal boxes “e” can be used also in zone 1. The protection principle of increased safety terminal boxes is acting in the causes that can start an ignition (e.g. sparks, materials overheating, cables movements, etc) and not in preventing that an internal explosion is sustained inside the enclosure (like flameproof enclosures “d”). Most of WEG increased safety terminal boxes have the constructive principles of flameproof enclosures “d” with additional Increased Safety requirements.

The main characteristics of Ex d e motors are:

- Terminal box components as well as connection cables must be firmly fastened (without allowing any movement);
- Special terminal block/bushings to avoid arcs and sparks and higher air and surface distances between conductive parts (clearances and creepages);
- Double grounding must be provided (one on the frame and the other inside the terminal box).

Applications:

Same as described for Ex d motors.

1.3.3 TYPE Ex t - Dust Ignition Protection by Enclosure “t”

(According to IEC/EN 60079-31 Standard)

The dust ignition protection by enclosure “t” is a type of protection for explosive dust atmospheres where electrical equipment is provided with an enclosure providing dust ingress protection and a means to limit surface temperatures.

This type of protection is divided into three levels of protection, “ta”, “tb and “tc”. For each type of protection, an Equipment Protection Level (EPL) has been assigned based on the risk of the equipment becoming an ignition source in a hazardous atmosphere.

| Dust ignition proof levels of protection | EPL |
|--|-----|
| ta | Da |
| tb | Db |
| tc | Dc |

Table 1.11 - EPL's for Ex t enclosures

Besides the thermal endurance and mechanical tests specified in IEC 60079-0 Standard, the motors with this protection shall be subjected to the following tests:

- Thermal test for the determination of maximum surface temperature as described in IEC 60079-0 Standard with the test voltage of $U_n \pm 10\%$;
- Alternatively, determination of the maximum surface temperature may be conducted within Zone A (as per IEC 60034-1 Standard).

In this case, the equipment shall be marked with “X” in accordance with IEC 60079-0 Standard and the specific condition of use shall include the information that the surface temperature determination was based on operation within Zone A (IEC 60034-1 Standard), typically $\pm 5\%$ of rated voltage.

- A positive internal pressure of at least:
 - 4 kPa for level of protection “ta” equipment, or
 - 2 kPa for level of protection “tb” and “tc” equipment.
 The tests shall be applied to the equipment for at least 60 s. During this test, any breathing or draining device shall be removed and the entry plugged. There shall be no evidence of damage to the enclosure due to the pressure applied.
- After the satisfactory completion of the pressure test, the motors shall satisfy the requirements of ingress protection as shown in the table:

| Level of protection | IIIC | IIIB | IIIA |
|---------------------|------|------|------|
| “ta” | IP6X | IP6X | IP6X |
| “tb” | IP6X | IP6X | IP5X |
| “tc” | IP6X | IP5X | IP5X |

Table 1.12 - IP levels for Ex t enclosures

Ingress Protection is to be determined in accordance with degree of protection (IP) of enclosures as specified in IEC 60079-0 Standard for level of protection “ta”, “tb” and “tc”. In the specific case of the level of protection “ta” the level of depression shall be increased to at least 4 kPa for a period of least 8 hours. Any grease in the joints should be removed before the IP test is performed.

Applications:

- Sugar refining plants;
- Breweries;
- Cement Plants;
- Textiles;
- Pharmaceutical;
- Chemical;
- Food process industries.

1.3.4. Selection of Equipment

(According to IEC/EN 60079-14 Standard)

To select the appropriate electrical equipment for hazardous areas, the following information is required:

- Classification of the hazardous area including the equipment protection level requirements, where applicable;
- Where applicable, gas, vapour or dust classification in relation to the electrical equipment group or subgroup;
- Temperature class or ignition temperature of the gas or vapour involved;
- Minimum ignition temperature of the combustible dust cloud, minimum ignition temperature of the combustible dust layer and minimum ignition energy of the combustible dust cloud;
- External influences and ambient temperature.

1.3.4.1. Selection according to Zones

Relationship between EPL's and zones is exhibited in table 1.13.

| Zone | Equipment protection level (EPL's) |
|------|------------------------------------|
| 0 | "Ga" |
| 1 | "Ga" or "Gb" |
| 2 | "Ga", "Gb" or "Gc" |
| 20 | "Da" |
| 21 | "Da" or "Db" |
| 22 | "Da", "Db" or "Dc" |

Table 1.13 - EPL's vs Zones

1.3.4.2. Selection according to Equipment Protection Level

According to IEC/EN Standards, EPL's have been allocated to each type of protection as follows:

| EPL | Type of protection | Code | According to |
|------|--|----------------|--------------|
| 'Ga' | Intrinsically safe | 'ia' | IEC 60079-11 |
| | Encapsulation | 'ma' | IEC 60079-18 |
| | Two independent types of protection each meeting EPL 'Gb' | - | IEC 60079-26 |
| | Protection of equipment and transmission systems using optical radiation | - | IEC 60079-28 |
| 'Gb' | Flameproof enclosures | 'db' | IEC 60079-1 |
| | Increased safety | 'eb' | IEC 60079-7 |
| | Intrinsically safe | 'ib' | IEC 60079-11 |
| | Encapsulation | 'mb' | IEC 60079-18 |
| | Oil immersion | 'ob' | IEC 60079-6 |
| | Pressurized enclosures | 'pxb' or 'pyb' | IEC 60079-2 |
| | Powder filling | 'qb' | IEC 60079-5 |
| | Fieldbus intrinsically safe concept (FISCO) | - | IEC 60079-27 |
| | Protection of equipment and transmission systems using optical radiation | - | IEC 60079-28 |

| EPL | Type of protection | Code | According to |
|------|--|--------------|--------------|
| 'Gc' | Intrinsically safe | 'ic' | IEC 60079-11 |
| | Encapsulation | 'mc' | IEC 60079-18 |
| | Non-sparking | 'n' or 'nAc' | IEC 60079-15 |
| | Restricted breathing | 'nRc' | IEC 60079-15 |
| | Energy limitation | 'nLc' | IEC 60079-15 |
| | Sparking equipment | 'nCc' | IEC 60079-15 |
| | Pressurized enclosures | 'pzc' | IEC 60079-2 |
| | Fieldbus non-incendive concept (FNICO) | - | IEC 60079-27 |
| | Protection of equipment and transmission systems using optical radiation | - | IEC 60079-28 |
| 'Da' | Intrinsically safe | 'ia' | IEC 60079-11 |
| | Encapsulation | 'ma' | IEC 60079-18 |
| | Protection by enclosure | 'ta' | IEC 60079-31 |
| 'Db' | Intrinsically safe | 'ib' | IEC 60079-11 |
| | Encapsulation | 'mb' | IEC 60079-18 |
| | Protection by enclosure | 'tb' | IEC 60079-31 |
| | Pressurized enclosures | 'pb' | IEC 61241-4 |
| 'Dc' | Intrinsically safe | 'ic' | IEC 60079-11 |
| | Encapsulation | 'mc' | IEC 60079-18 |
| | Protection by enclosure | 'tc' | IEC 60079-31 |
| | Pressurized enclosures | 'pc' | IEC 61241-4 |

Table 1.14 - EPL's vs Types of Protection

1.3.4.3. Selection according to equipment grouping

Relationship between gas/vapour or dust subdivision and equipment group:

| Location gas/vapour or dust subdivision | Permitted equipment group (EPL's) |
|---|-----------------------------------|
| IIA | IIA, IIB or IIC |
| IIB | IIB or IIC |
| IIC | IIC |
| IIIA | IIIA, IIIB or IIIC |
| IIIB | IIIB or IIIC |
| IIIC | IIIC |

Table 1.15 - EPL's vs Equipment Groups

1.3.4.4. Selection according to the ignition temperature of the gas, vapour or dust and ambient temperature

The electrical equipment shall be so selected that its maximum surface temperature will not reach the ignition temperature of any gas, vapour or dust which may be present.

If the marking of the electrical equipment does not include an ambient temperature range, the equipment is designed to be used within the temperature range -20°C to +40°C. If the marking of the electrical equipment includes an ambient temperature range, the equipment is designed to be used within that range.

If the ambient temperature is outside the temperature range or if there is a temperature influence from other factors, e.g. the process temperature or exposure to solar radiation, the effect on the equipment shall be considered and measures taken duly documented.

GROUP I - Underground Coal Mines (methane and coal dust)

| Maximum surface temperature * | Conditions |
|-------------------------------|---|
| 150° C | Where coal dust can form a layer |
| 450° C | Where coal dust is not likely to form a layer |

* on any surface of the enclosure

Table 1.16 - Allowable surface temperature for Group I motors

In order to validate the maximum surface temperature, WEG motors are tested under the most adverse rating with 90% of the rated voltage supply (according to IEC/EN 60079-0 Standard).

GROUP II - Gas and Vapours

| Temperature class required by the area classification | Ignition temperature of gas or vapour in °C | Allowable temperature classes of equipment |
|---|---|--|
| T1 | > 450 | T1 - T6 |
| T2 | > 300 | T2 - T6 |
| T3 | > 200 | T3 - T6 |
| T4 | > 135 | T4 - T6 |
| T5 | > 100 | T5 - T6 |
| T6 | > 85 | T6 |

Table 1.17 - Allowable surface temperature for Group II motors

In order to validate the maximum surface temperature, WEG motors are tested under the most adverse rating with 90% of

the rated voltage supply, assuring a safety margin of 5K for temperature classes T3 to T6 and 10K for T1 and T2 classes (according to IEC/EN 60079-0 Standard).

GROUP III - Conductive Dust (IIIC)

- Without dust layers: Maximum surface temperature of the apparatus shall not exceed the assigned value. For W22Xd motors the standard assigned temperature is T125°C.

In order to validate the maximum surface temperature, WEG motors are tested under the most adverse rating with 90% of the rated voltage supply (according to IEC/EN 60079-0 Standard).

- With dust layers: Maximum surface temperature of the apparatus must be determined for a given depth of dust layer. Please refer to WEG for motor selection in this condition.

1.3.4.5. Summary

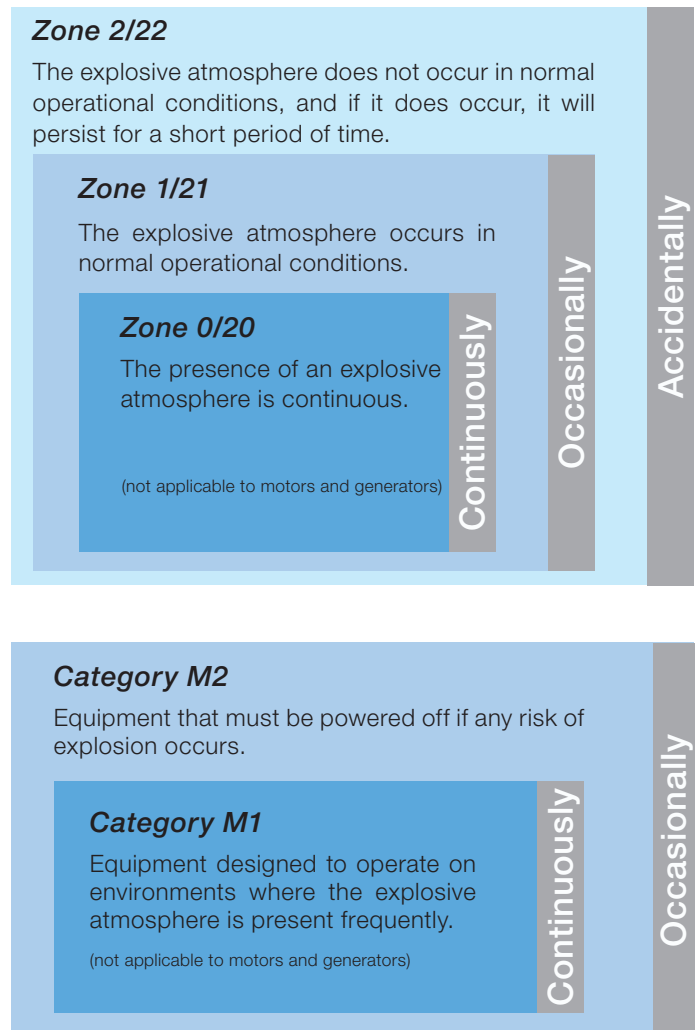

Figure 1.05 - Zones classification

1.4. General Standards

Beyond the particular requirements for Hazardous Areas, WEG motors are manufactured in compliance with General IEC/EN and equivalent National Standards related with construction and performance. The main applicable Standards are described below:

| | |
|------------------------|--|
| IEC/EN 60034-1 | Rating and performance |
| IEC/EN 60034-2-1 | Determination of losses and efficiency |
| IEC 60072 and EN 50347 | Outputs and dimensions |
| IEC/EN 60034-5 | Mechanical protection |
| IEC/EN 60034-6 | Cooling method |
| IEC/EN 60034-7 | Mounting arrangements |
| IEC/EN 60085 | Insulation class |
| IEC/EN 60034-8 | Terminals identification and rotation |
| IEC/EN 60034-9 | Noise limits |
| IEC/EN 60034-11 | Thermal protection |
| IEC/EN 60034-12 | Starting performance |
| IEC/EN 60034-14 | Mechanical vibration limits |

Table 1.18 - General Standards



1.5. North American Standards and Regulations

The use of electrical equipment in hazardous areas in the U.S. and Canada requires specific assessment for the safety of persons and property according to the framework of the National Fire Protection Association documents, namely the NFPA 70 or National Electrical Code (NEC). Besides NEC compliance, electric motors and generators for use in hazardous locations (hazloc) must also be designed, manufactured and certified in accordance with UL 674 and CSA C22.2 No. 145-11 Standards. The hazloc certification obliges a previous certification for General Locations in accordance with the standards C22.2 No. 100-04 and UL 1004.

NEC contains two different classification systems, the Division Classification System and the Zones Classification System, for electrical and electronic equipment concerning hazardous locations where fire or explosion hazards may exist due to flammable gases, vapors, liquids or combustible dusts.



The Division Classification System

The Division Classification System is defined in NEC Article 500 and comprehends the following classified locations:

| Class | Definition | Division | Definition |
|-------|---|----------|---|
| I | Locations in which flammable gases, flammable liquid-produced vapors or combustible liquid-produced vapors are or may be present in the air in quantities sufficient to produce explosive or ignitable mixtures. | 1 | <ul style="list-style-type: none"> - In which ignitable concentrations of flammable gases or vapors can exist under normal operation conditions, or - In which ignitable concentrations of flammable gases or vapors above their flash points may exist frequently because of repair or maintenance operations or because of leakages, or - In which breakdown or faulty operation of equipment or processes might release concentrations of flammable gases or vapors and might also cause simultaneous failure of electrical equipment in such a way as to directly cause the electrical equipment to become a source of ignition. |
| | | 2 | <ul style="list-style-type: none"> - In which volatile flammable gases or vapors are handled, processed or used and will normally be confined within closed containers or closed systems from which they can escape only in case of accidental rupture or breakdown of such containers or systems or in case of abnormal operation of equipment, or - In which ignitable concentrations of flammable gases or vapors are normally prevented by positive mechanical ventilation and which might become hazardous through failure or abnormal operation of the ventilating equipment, or - That is adjacent to a Class I, Division 1 location, and to which ignitable concentrations of flammable gases or vapors above their flash points might occasionally be communicated unless such communication is prevented by adequate positive-pressure ventilation from a source of clean air and effective safeguards against ventilation failure are provided. |
| II | Locations that are hazardous because of the presence of combustible dust | 1 | <ul style="list-style-type: none"> - In which combustible dust in the air under normal operating conditions in quantities sufficient to produce explosive or ignitable mixtures, or - Where mechanical failure or abnormal operation of machinery or equipment might cause such explosive or ignitable mixtures to be produced, and might also provide a source of ignition through simultaneous failure of electrical equipment, through operation of protection devices, or from other causes, or - In which Group E combustible dusts may be present in quantities sufficient to be hazardous. |
| | | 2 | <ul style="list-style-type: none"> - In which combustible dust due to abnormal operations may be present in the air in quantities sufficient to produce explosive or ignitable mixtures, or - Where combustible dust accumulations are present but are normally insufficient to interfere with the normal operation of electrical equipment or other apparatus, but could as a result of infrequent malfunctioning of handling or processing equipment become suspended in the air, or - In which combustible dust accumulations on, in, or in the vicinity of the electrical equipment could be sufficient to interfere with the safe dissipation of heat from electrical equipment, or could be ignitable by abnormal operation or failure of electrical equipment. |
| III | Locations that are hazardous because of the presence of easily ignitable fibers or where materials producing combustible flyings are handled, manufactured or used but in which such fibers/flyings are not likely to be in suspension in the air in quantities sufficient to produce ignitable mixtures. | 1 | - Location in which easily ignitable fibers/flyings are handled, manufactured or used |
| | | 2 | - Location in which easily ignitable fibers/flyings are stored or handled other than in the process of manufacture. |

Table 1.19 - Classes and Divisions classified locations

Equipment intended to be used in a certain Class location must be identified also for a specific group of the gas or vapor that can be present.

| Class | Group | Typical Gas |
|-------|-------|-------------|
| I | A | Acetylene |
| | B | Hydrogen |
| | C | Ethylene |
| | D | Propane |

| Class | Group | Typical Combustible Dusts |
|-------|-------|--|
| II | E | Metal dusts, including aluminum and magnesium. |
| | F | Carbonaceous dusts, including coal, carbon black, charcoal and coke. |
| | G | Combustible dusts not included in Group E or F, including flour, grain, wood, plastic and chemicals. |

| Class | Group | Typical Combustible Fibers / Flyings |
|-------|----------------|--------------------------------------|
| III | Not Applicable | Cotton |

Table 1.20 - Classes vs Groups

Explosion proof equipment is permitted for Class I, Division 1. Equipment that has been identified for a Division 1 location can be used in a Division 2 location of the same Class and Group. Equipment for Class I and Class II shall be classified and marked with the maximum safe operating surface temperature using the T Codes in Table 1.21.

| Temperature Class (T Code) | Maximum Surface Temperature | |
|----------------------------|-----------------------------|-----|
| | °C | °F |
| T1 | 450 | 842 |
| T2 | 300 | 572 |
| T2A | 280 | 536 |
| T2B | 260 | 500 |
| T2C | 230 | 446 |
| T2D | 215 | 419 |
| T3 | 200 | 392 |
| T3A | 180 | 356 |
| T3B | 165 | 329 |
| T3C | 160 | 320 |

| Temperature Class (T Code) | Maximum Surface Temperature | |
|----------------------------|-----------------------------|-----|
| | °C | °F |
| T4 | 135 | 275 |
| T4A | 120 | 248 |
| T5 | 100 | 212 |
| T6 | 85 | 185 |

Table 1.21 - Maximum Surface Temperature Classification

For Class I equipment the marking specified temperature shall not exceed the ignition temperature of the specific gas or vapor to be encountered.

Also, for Class II equipment the marking specified temperature shall be less than the ignition temperature of the specific dust to be encountered.

The Zone Classification System

The Zone Classification System is defined in NEC Articles 505 and 506 and is similar to the IEC definition of Zones.

Zone Classification System is an alternative to Division Classification System where locations, in which flammable gases or vapors are or may be present in the air in quantities sufficient to produce explosive or ignitable mixtures, are classified as Class I, Zone 0, 1 or 2 (NEC 505) or locations, where fire and explosion hazards may exist due to combustible dust or ignitable fibers/flyings, are classified as Zone 20, 21 or 22 (NEC 506).

| Class | Definition | Zone | Definition |
|-------|---|------|---|
| I | Locations where fire or explosion hazards may exist due to flammable gases, vapors or liquids | 0 | - In which ignitable concentrations of flammable gases or vapors are present continuously, or - In which ignitable concentrations of flammable gases or vapors are present for long periods of time. |
| | | 1 | - In which ignitable concentrations of flammable gases or vapors are likely to exist under normal operating conditions, or - In which ignitable concentrations of flammable gases or vapors may exist frequently because of repair or maintenance operations or because of leakage, or - In which equipment is operated or processes are carried on, of such a nature that equipment breakdown or faulty operations could result in the release of ignitable concentrations of flammable gases or vapors and also cause simultaneous failure of electrical equipment in a mode to cause the electrical equipment to become a source of ignition, or - That is adjacent to a Class I, Zone 0 location from which ignitable concentrations of vapors could be communicated, unless communication is prevented by adequate positive pressure ventilation from a source of clean air and effective safeguards against ventilation failure are provided. |
| | | 2 | - In which ignitable concentrations of flammable gases or vapors are not likely to occur in normal operation and, if they do occur, will exist only for a short period, or - In which volatile flammable liquids, flammable gases, or flammable vapors are handled, processed, or used but in which the liquids, gases, or vapor normally are confined within closed containers of closed systems from which they can escape, only as a result of accidental rupture or breakdown of the containers or system, or as a result of the abnormal operation of the equipment with which the liquids or gases are handled, processed, or used, or - In which ignitable concentrations of flammable gases or vapors normally are prevented by positive mechanical ventilation but which may become hazardous as a result of failure or abnormal operation of the ventilation equipment, or - That is adjacent to a Class I, Zone 1 location from which ignitable concentrations of flammable gases or vapors could be communicated, unless such communication is prevented by adequate positive pressure ventilation from a source of clean air and effective safeguards against ventilation failure are provided. |

Table 1.22 - Classes and Zones classified locations for gas and vapor

The different air mixtures are also grouped as in IEC standards.

| Group | Typical Gas |
|-------|---|
| IIC | Acetylene, Hydrogen |
| IIB | Ethylene, Acetaldehyde |
| IIA | Acetone, Ammonia, Ethyl Alcohol, Gasoline, Methane, Propane |

Table 1.23 - Typical gases groups

Equipment temperature class shall be indicated using the temperature class (T Code) shown in Table 1.24.

| Temperature Class (T Code) | Maximum Surface Temperature |
|----------------------------|-----------------------------|
| | °C |
| T1 | 450 |
| T2 | 300 |
| T3 | 200 |
| T4 | 135 |
| T5 | 100 |
| T6 | 85 |

Table 1.24 - Maximum Surface temperature for Group II Electrical Equipment Classification

Flameproof “d” and Increased Safety “e” equipment are permitted for Class 1, Zone 1 or Zone 2 locations.

| Zone | Definition |
|------|--|
| 20 | - An area where combustible dust or ignitable fibers/flyings are present continuously or for long periods of time in quantities sufficient to be hazardous. |
| 21 | - An area where combustible dust or ignitable fibers/flyings are likely to exist occasionally under normal operation in quantities sufficient to be hazardous. |
| 22 | - An area where combustible dust or ignitable fibers/flyings are not likely to occur under normal operation in quantities sufficient to be hazardous. |

Table 1.25 - Zones for combustible dust

Comparison between Division and Zone classification:

| Type of Area | NEC and CEC (North America) | CENELEC and IEC |
|----------------------------------|--------------------------------|------------------|
| Continuous Hazard | Division 1 or Zone 0 / Zone 20 | Zone 0 / Zone 20 |
| Intermittent Hazard | Division 1 or Zone 1 / Zone 21 | Zone 1 / Zone 21 |
| Hazard Under Abnormal Conditions | Division 2 or Zone 2 / Zone 22 | Zone 2 / Zone 22 |

Table 1.26 - Area Classification (Division vs Zone)

Product Information

| | |
|------------------------------------|-----------|
| <u>2.1. Product Ranges</u> | <u>19</u> |
| <u>2.2. Product Certifications</u> | <u>21</u> |

2. Product Information

2.1. Product Ranges

This catalogue includes the medium voltage and high voltage WEG flameproof motor lines:

- W22Xd - Frames 315L to 560H/G with rib-cooled design;
- W22Xd..T - Frames 560J/H to 710H/G with tube-cooled design.

This new WEG range, is designed to offer not only safety, but also significantly lower energy consumption, reduced noise and vibration, higher reliability, easier maintenance and lower cost of ownership.

Competitive, complete and flexible, the W22Xd line is available in the following executions:

- Ex d(e) I Mb
- Ex d(e) IIB T4 Gb
- Ex d(e) IIC T4 Gb
- Ex d(e) IIB T4 Gb Ex tb IIIC T125°C (T135°C) Db IP6X
- Ex d(e) IIC T4 Gb Ex tb IIIC T125°C (T135°C) Db IP6X

On request W22Xd motors may be supplied with certification for North America (Class I, Division 1 / Class I, Zone 1 or 21).

Available outputs in Medium Voltage (1100V < Un ≤ 6600V)

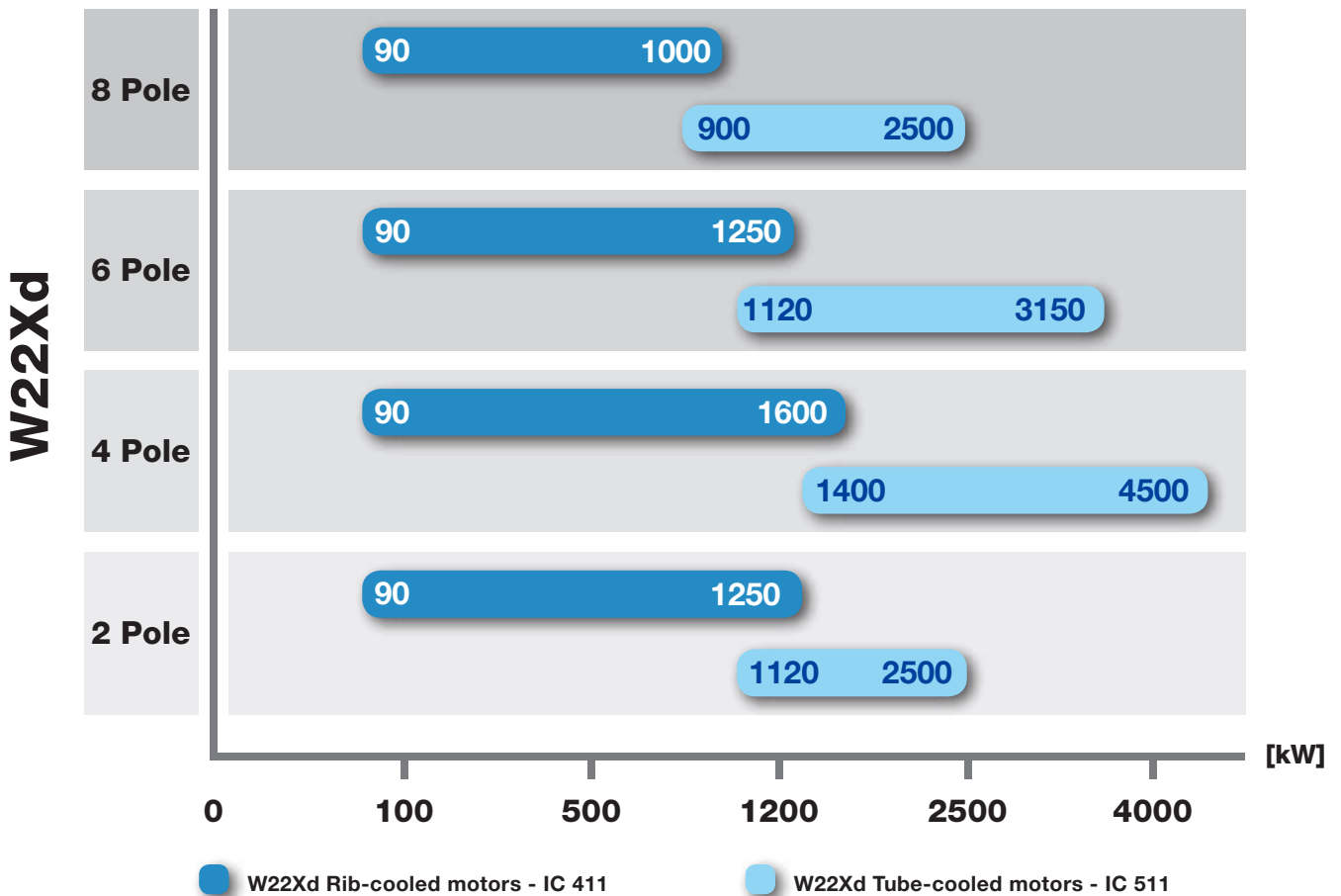

Figure 2.01 - Medium Voltage flameproof range

Available outputs in High Voltage ($6600V < U_n \leq 11000V$)

2

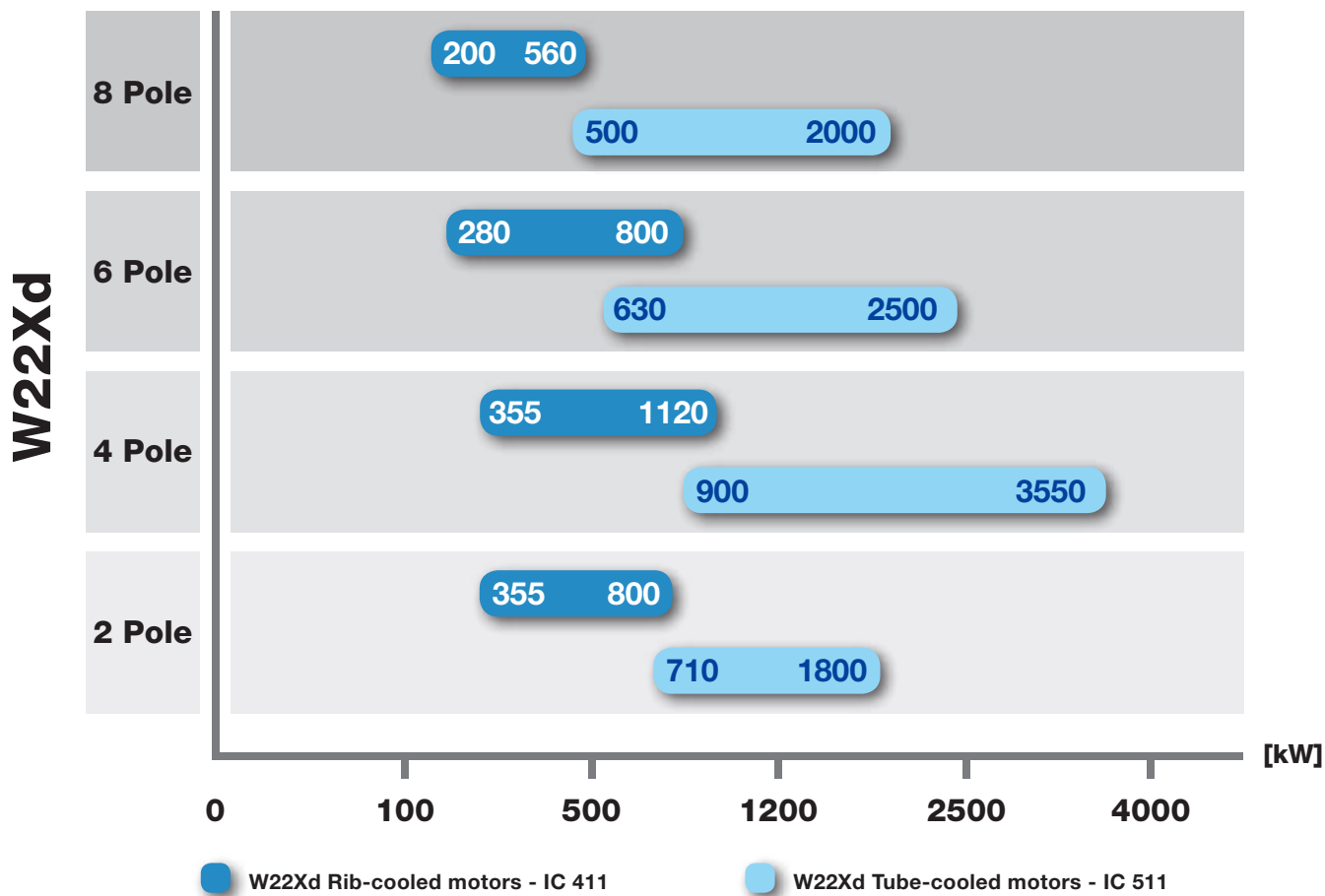

Figure 2.02 - High Voltage flameproof range

2.2. Product Certifications

2.2.1. Certifications and Notified Bodies

| Line: W22Xd | |
|---|--|
| Possible markings ⁽¹⁾ | Ex d(e) I Mb |
| | Ex d(e) IIB T4 Gb |
| | Ex d(e) IIC T4 Gb |
| | Ex d(e) IIB T4 Gb Ex tb IIIC T125°C Db IP6X |
| | Ex d(e) IIB T4 Gb Ex tb IIIC T135°C Db IP6X |
| | Ex d(e) IIC T4 Gb Ex tb IIIC T125°C Db IP6X |
| | Ex d(e) IIC T4 Gb Ex tb IIIC T135°C Db IP6X |
| Notified Body | Certifications |
|  INERIS |   WORLDWIDE EUROPE |
|  TUV |  BRAZIL |
|  CCVE |   ⁽²⁾ RUSSIA, BELARUS & KAZAKHSTAN |
|  PESO / COOE |  INDIA |
|  CSA |  ⁽³⁾ C US CANADA & US |
|  SITIAS - NEPSI |  CHINA |

| | |
|--|---|
|  INTERTEK |  SAUDI ARABIA |
|  SONCAP |  NIGERIA |

Table 2.01 - W22Xd line certifications

(1) Markings for ATEX/IECEX. Different markings are used for North America. Other certifications may require complementary markings.

(2) Technical Regulation of the Customs Union (TR CU 012/2011) replaces  since 15 February 2013 and is valid for Russian Federation, Republic of Belarus and Republic of Kazakhstan.

(3) Certification on a case by case basis.

For other Local/Regional certifications please refer to us.

Marine and Offshore Approvals

W22Xd motors also comply with the requirements of all major Classifications Societies members of IACS (International Association of Classification Societies).

| | | | | |
|---|---|---|---|--|
|  CCS CHINA |  BV FRANCE |  GL GERMANY |  RINA ITALY |  NKK JAPAN |
|  DNV NORWAY |  RMRS RUSSIA |  KR SOUTH KOREA |  LRS UK |  ABS USA |

2.2.2. Certificates of Equipment

Examples of identification and certificates

- **IECEX:** IECEX INE 12.0037X
- **ATEX:** INERIS12ATEX0052X

2



Figure 2.03 - Examples of certificates

2.2.3. Marking of Equipment

Markings according to ATEX Directives and IEC/EN standards

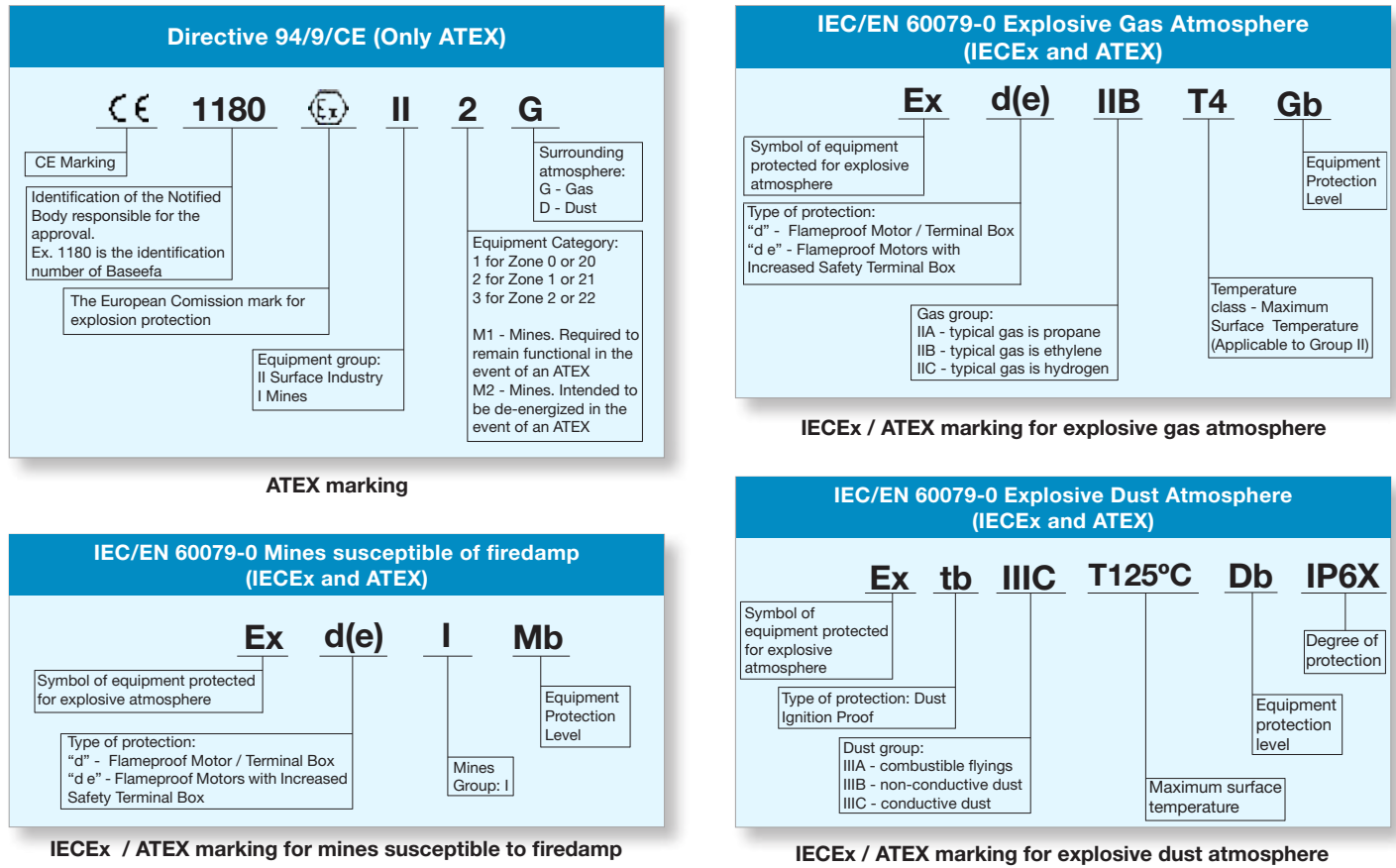

Figure 2.04 - ATEX and IECEx markings

Markings according to North American Standards and Regulations

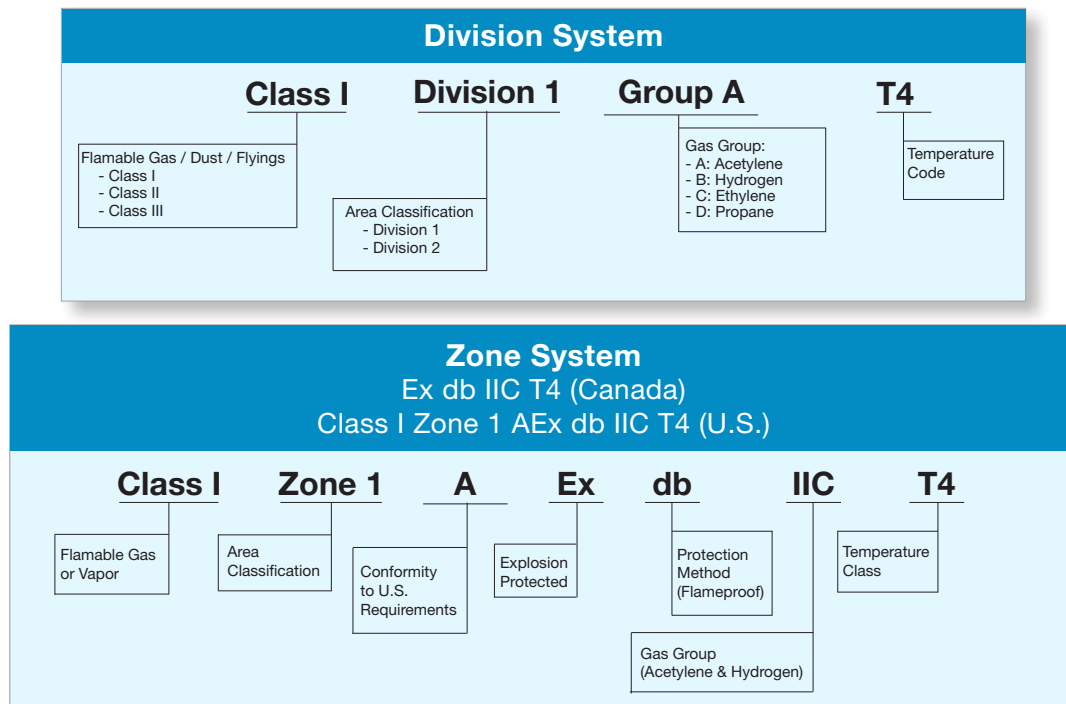

Figure 2.05 - North American markings

Product Range Information

Terminology

The below terminology standardizes the designation for W22 series hazardous areas motors globally and clearly identifies the classified area to which the motor is designed.

This terminology stipulates the following:

- W22Xd - Flameproof Ex d motors
- W22Xn - Non-sparking Ex nA motors
- W22Xe - Increased Safety Ex e motors
- W22Xtb - Protection by enclosure
Zone 21 Dust Ignition Proof motors
- W22Xtc - Protection by enclosure
Zone 22 Dust Ignition Proof motors

The “W22Xd” terminology shall include the following hazardous area complementary information:

- W22XdB - Zones 1 and 2, gas group IIB
- W22XdC - Zones 1 and 2, gas group IIC
- W22XdM - Group I, category M2

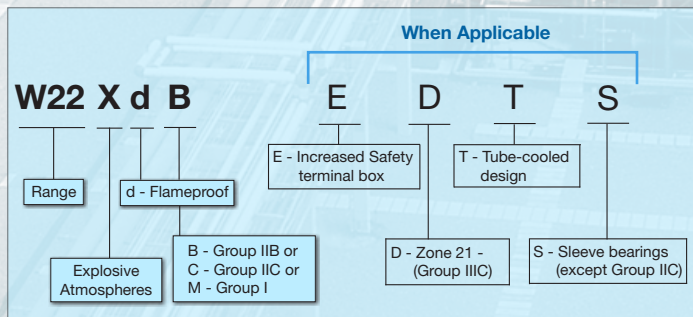

2.2.4. Certification Nameplates

The W22Xd certification markings are given in an additional or in the main nameplate. Examples of certification nameplates used on WEG MV/HV motors are given below for better understanding of markings:

■ **ATEX and IECEx Certification Nameplates**

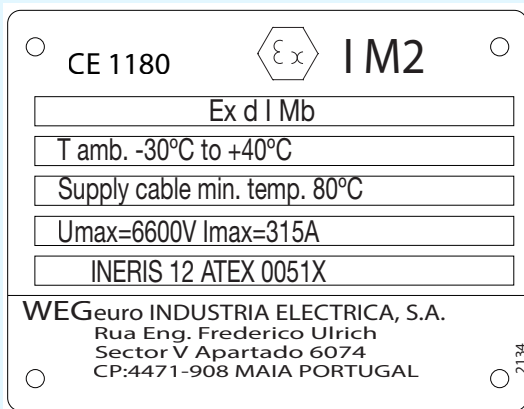

W22XdM - ATEX

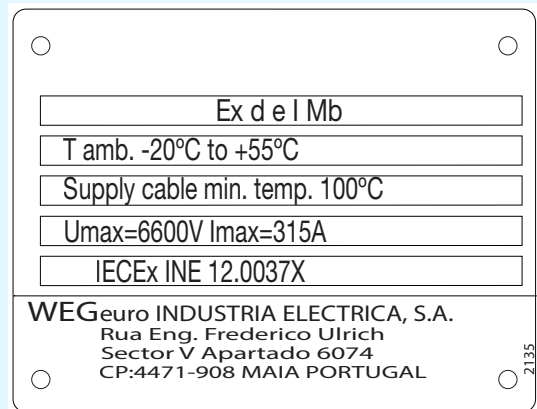

W22XdME - IECEx

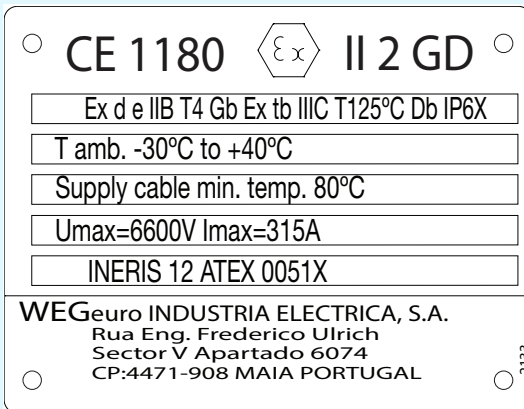

W22XdBED - ATEX

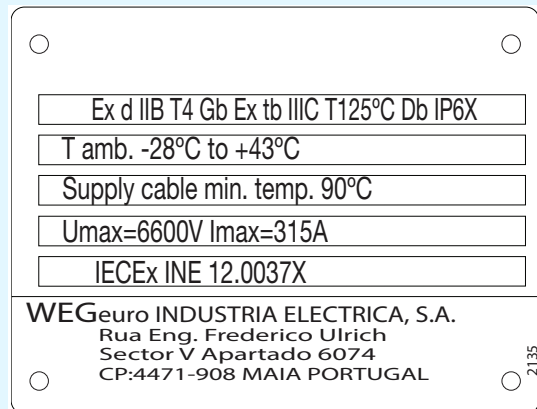

W22XdBD - IECEx

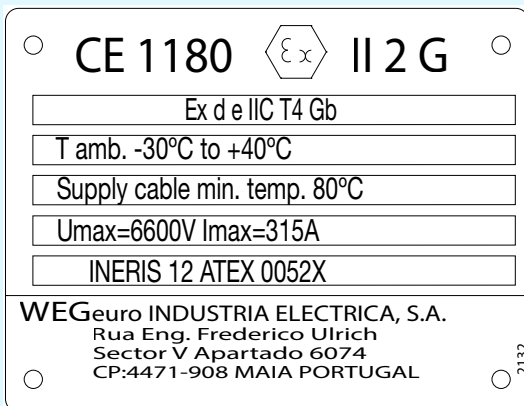

W22XdCE - ATEX

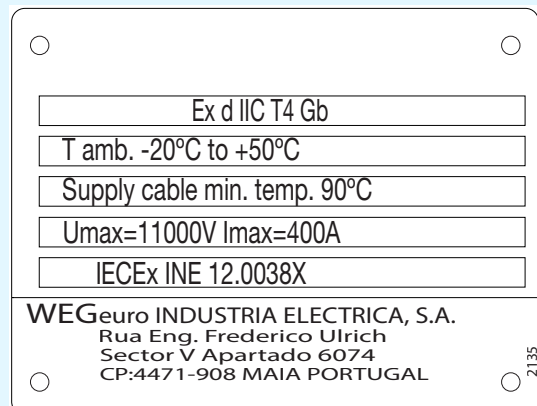

W22XdC - IECEx

Figure 2.06 - Examples of certification nameplates

■ INMETRO Nameplate

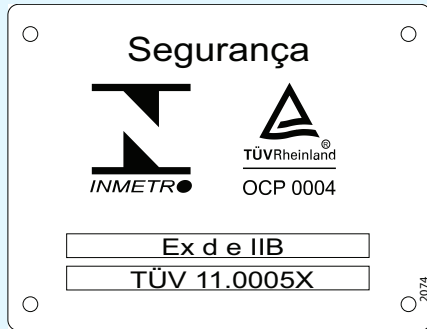

Brazil

■ TR CU Nameplate



Russia, Belarus & Kazakhstan

Figure 2.07 - Examples of additional markings

■ Main Nameplate

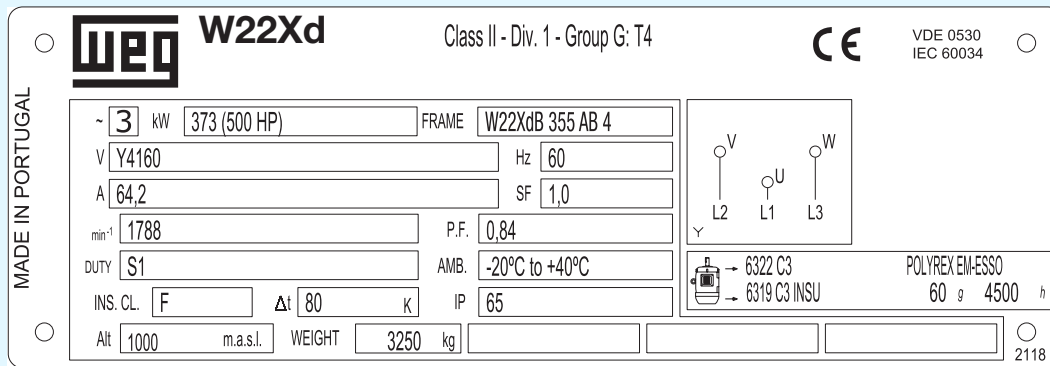

Figure 2.08 - Example of North American marking

Mechanical Features

| | | |
|--------------|---|-----------|
| 3.1. | Enclosure Main Parts | 29 |
| 3.2. | Shaft and Bearings | 37 |
| 3.3. | Degree of Protection | 50 |
| 3.4. | Cooling System - IC and Noise Level | 50 |
| 3.5. | Vibration Level | 52 |
| 3.6. | Impact Resistance | 53 |
| 3.7. | Painting | 53 |
| 3.8. | Mounting Arrangements - IM | 54 |
| 3.9. | Nameplates and Additional Plates | 55 |
| 3.10. | Assembly Systems for Foot Mounted Motors | 57 |
| 3.11. | Seismic Hazards | 57 |
| 3.12. | Mechanical Protection Equipment | 57 |

3. Mechanical Features

The information included in this section refers to standard construction and the most common optional features for W22Xd line:

- Ribbed frames from IEC 315L up to 560H/G;
- Tube-cooled frames from IEC 560J/H up to 710H/G.

W22Xd line adopts modular principles of construction that can be easily applied for special and/or customized applications. For more information, please contact your WEG branch or representative.

3.1. Enclosure Main Parts

As standard, W22Xd ribbed motors are totally enclosed fan cooled machines (IC411), according to IEC/EN 60034-7 Standard in IM B3 mounting form and optionally in flange and vertical arrangements.

W22Xd tube-cooled motors have internal and external cooling circuits with an air-air heat exchanger incorporated in the frame. These machines are IC511, according to IEC/EN 60034-7 Standard in IM B3 mounting form and optionally in flange and vertical arrangements.

3.1.1. Frames

3.1.1.1. Rib-Cooled Motors

The W22Xd ribbed frames 315L to 500K/H (figure 3.01) are manufactured in cast iron FC-200 (EN-GJL-200), providing high levels of mechanical strength to meet the most demanding applications. The cooling fins are designed to minimize the accumulation of liquids and dust over the motor. The design of the frame guarantees an aerodynamic concept to optimize airflow and cooling surface area.



Figure 3.01 - W22Xd rib-cooled cast iron frame

W22Xd ribbed frame 560H/G (figure 3.02) is manufactured in welded steel with similar design and also providing a high level of mechanical strength.



Figure 3.02 - W22Xd rib-cooled steel frame

Solid integrated feet with high mechanical stiffness, designed to allow easier alignment and installation (figure 3.03).



Figure 3.03 - Motor feet

3.1.1.2. Tube-Cooled Motors

The W22Xd tube-cooled frames 560J/H to 710H/G (figure 3.04) are manufactured in steel S 355 J 2 G 3 (EURONORM) with the adoption of the best technics and control methods concerning the welding procedures.

The frames have internal longitudinal ribs to assure the best rigidity for stator assembling and increasing the levels of mechanical strength in order to meet the most demanding applications. There are two symmetrical air internal chambers, each one with a ripple design to improve cooling efficiency. The incorporated air-air heat exchanger uses stainless steel AISI 304 tubes manufactured according to EN 10217-7 and ISO 1127.

Tubes are mounted in the frame by a WEG specific industrial press fit technique avoiding welding processes and assuring a total enclosure sealing.

The external smooth surface, of the frame, is designed to minimize the accumulation of liquids and dust over the motor. Also, maintenance and housekeeping actions are reduced.



Figure 3.04 - W22Xd tube-cooled steel frame

Solid integrated feet with high mechanical stiffness, designed to allow easier alignment and installation (figure 3.05).

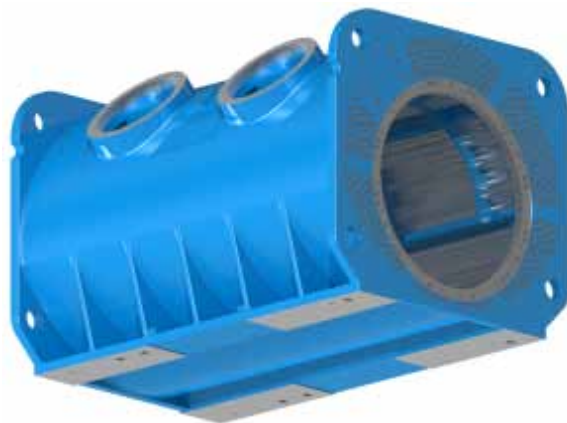

Figure 3.05 - Motor feet

3.1.2. Eyebolts

3.1.2.1. Rib-Cooled Motors

W22Xd rib-cooled motors are supplied with two eyebolts and have multiple threaded holes for fastening of the eyebolts, allowing easier handling of the motor, as described on table 3.01 and figures 3.06 and 3.07:

| Number of eyebolts | Frames 315L up to 560H/G |
|--------------------|---|
| 2 | Motors with feet and with side or top mounted terminal box: These motors have 2 threaded holes in the upper part of the frame for fastening of the eyebolts (figure 3.06). |
| 2 | Motors without feet: These motors have 4 threaded holes, 2 for vertical mounting and 2 for horizontal mounting (figure 3.07). |

Table 3.01 - W22Xd rib-cooled motors eyebolts



Figure 3.06 - Threaded holes for fastening the eyebolts for motors with feet



Figure 3.07 - Threaded holes for fastening the eyebolts for motors without feet

3.1.2.2. Tube-Cooled Motors

The frames of W22Xd tube-cooled motors are supplied with four lifting holes allowing easier handling of the motor, as described on table 3.02 and figures 3.08 and 3.09:

| Number of eyebolts | Frames 560J/H up to 710H/G |
|--------------------|--|
| 4 | Motors with or without feet and with side or top mounted terminal box for horizontal mounting: These motors have 4 lifting holes in the upper part of the frame to fix the handling straps or chains (figure 3.08). |
| 4 | Motors with or without feet for vertical mounting: These motors have 4 lifting holes in the upper part of the frame to fix the handling straps or chains (figure 3.09). |

Table 3.02 - W22Xd tube-cooled motors eyebolts



Figure 3.08 - Lifting holes for handling horizontal motors



Figure 3.09 - Lifting holes for handling vertical motors



Figure 3.10 - W22Xd rib-cooled motors drive end endshield

The non drive end endshield is designed to offer the minimum resistance to the airflow (figure 3.11).

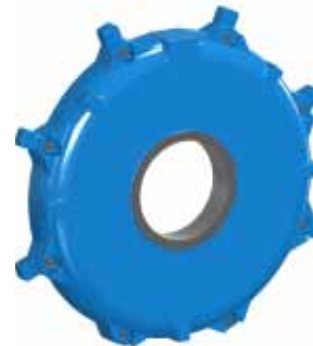

Figure 3.11 - W22Xd rib-cooled motors non drive end endshield

All the housings of the fixing bolts were carefully designed in order to protect the bolts against accidental impacts and water accumulation.

3.1.3.2. Tube-Cooled Motors

The endshields are manufactured in steel S 355 J 2 G 3 (EURONORM) and designed to minimize welding operations. The internal ribbing of the endshields guarantees a high mechanical strength and rigidity.

All the housings of the fixing bolts were carefully designed in order to protect the bolts against accidental impacts and water accumulation. Some of these housings are threaded to allow an easy mounting, dismounting and handling of the endshields.

The external smooth design of the endshields allows also reduced actions of maintenance and housekeeping. In the non drive end side this design offers a minimum resistance to the air flow.

Drive end and non drive end shields are very similar in design, see figure 3.12.

3.1.3. Endshields

3.1.3.1. Rib-Cooled Motors

To ensure low bearing operating temperatures, the drive end endshield (figure 3.10) is designed with fins for better thermal heating dissipation, resulting in extended lubrication intervals.



Figure 3.12 - W22Xd tube-cooled motors endshield



Figure 3.15 - Vibration monitoring directions on W22Xd tube-cooled motor

3.1.4. Vibration Monitoring

3

All W22Xd motors endshields can be supplied with flat areas for easier placement of vibration probes available in both vertical and horizontal directions. W22Xd motors are supplied with M8 threaded nipples as standard. Other threaded hole sizes can be supplied. Vibration probes can be supplied together with the motor, under request.

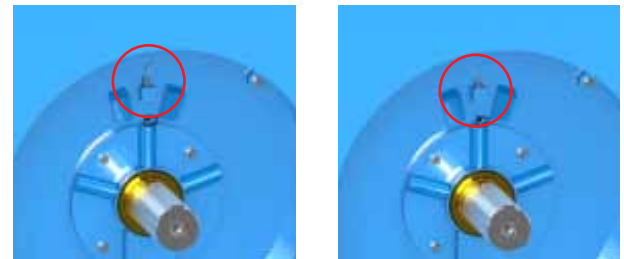

Figure 3.16 - Example of mounted vibration probes on W22Xd tube-cooled motor



Figure 3.13 - Vibration monitoring directions on W22Xd ribbed motor

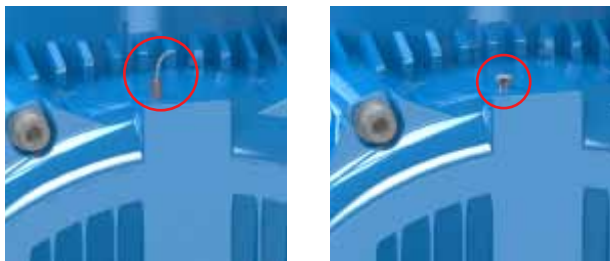

Figure 3.14 - Example of mounted vibration probes on W22Xd ribbed motors

3.1.5. Drain Plugs

Motors can be fitted with certified drain plugs in the lowest part of the frame (figure 3.17 and 3.18) for drainage of water that may condense inside.

Internally, the enclosure is designed in order to allow the condensate water to flow into the drain holes.

It is mandatory not to remove or move the drain plugs.



Figure 3.17 - Drain plugs location on ribbed frame

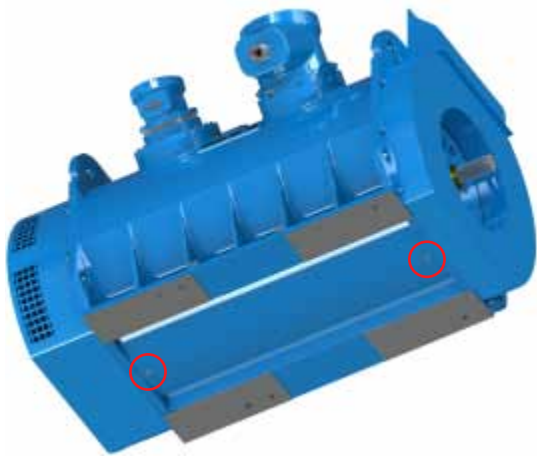

Figure 3.18 - Drain plugs location on tube-cooled frame

The terminal boxes can also be provided with the same certified plugs.



Figure 3.19 - Drain plug on terminal box

3.1.6. Terminal Boxes

3.1.6.1. Main Terminal Boxes

W22Xd line has multiple solutions of cast iron power terminal boxes for a wide voltage and current ranges equipped with internal and external ground connection terminals and certified fault level capacity (as optional).

The WTBX M (figure 3.20) power terminal box is standard for Medium Voltage motors for Group I (mines) and Gas Groups IIB/IIC. This terminal box is made of FC-200 (EN-GJL-200) having a diagonally split design for easier access to terminal leads and connections. Optionally, WTBX M, can be equipped with certified drain plugs, gland plates, bonding jumpers and multiple cable entries.

Also available for neutral point (star point) version.



Figure 3.20 - WTBX M - Main terminal box for medium voltage motors

The WTBX L (figure 3.21) power terminal box is standard for Medium Voltage motors for currents higher than 630A and standard for High Voltage motors. It is also certified for Group I (mines) and Gas Groups IIB/IIC. This terminal box is made of FC-200 (EN-GJL-200) having a diagonally split design for easier access to terminal leads and connections. Optionally, WTBX L, can be equipped with certified drain plugs, gland plates, bonding jumpers and multiple cable entries.

Also available for neutral point (star point) version.



Figure 3.21 - WTBX L - Main terminal box for high voltage motors

Main terminal boxes are supplied, as standard, with metric threaded holes for cable entries. The sizes and quantities of holes are detailed in Section 5 - Standard and Optional Features (Scope).

All cable entries, except one, are fitted with certified threaded plugs, according to the type of protection, EPL (Equipment Protection Level), and degree of protection indicated on nameplate.

The leads are connected to individual conductor bushings (see figure 3.22).

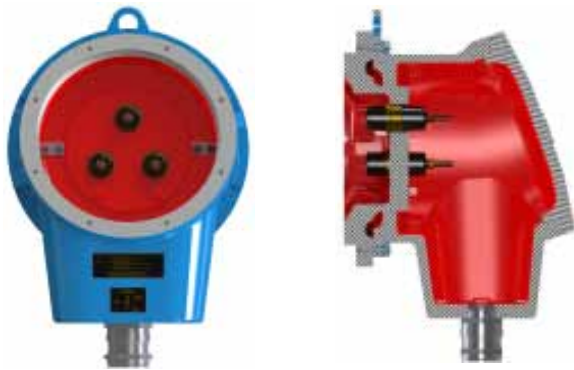

Figure 3.22 - WTBX M - Terminal box fitted with standard conductor bushings



Figure 3.25 - Tube-cooled motor with Phase Segregated Terminal Box

Motors can also be supplied in “Ex d e” version, which means that, besides the flameproof protection, the motor is fitted with an Ex e, increased safety, terminal box (see figure 3.23).

A Phase Insulated Power Terminal Box (figure 3.26) is also available as optional for Medium and High Voltage.

3

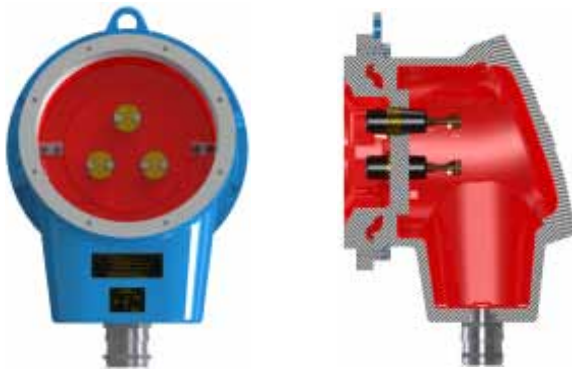

Figure 3.23 - WTBX M terminal box fitted with Ex d e conductor bushings



Figure 3.26 - Phase Insulated Terminal Box

For additional protection, surge arrestors, surge capacitors and current transformers are also available for W22Xd motors.

Complete technical data of main and optional terminal boxes available in Section 7 - Terminal Boxes.

Complete technical data of power and protection terminal boxes are shown in Section 7 - Terminal boxes.

Available as optional for Medium Voltage and High Voltage a Phase Segregated Power Terminal Box (figures 3.24 and 3.25) with a degree of protection of IP67 and high fault rated level (44kA for 0,25s) can be supplied.

3.1.6.2. Auxiliary Terminal Boxes



Figure 3.24 - Rib-cooled motor with Phase Segregated Terminal Box

W22Xd MV and HV motors are supplied, as standard, with an auxiliary terminal box for connection of windings Pt100, bearing Pt100 and space heaters.

There are two different standard auxiliary terminal boxes that are used regarding W22Xd motors frame sizes:

- WTBX XS - for frames 315L and 355M/L;
- WTBX S - for frames 355A/B and above.

These terminal boxes are made of FC-200 (EN-GJL-200) cast iron.

As standard there are 3xM20x1,5 cable entries and all of them are fitted with certified threaded plugs, according to the type of protection EPL (Equipment Protection Level) and degree of protection indicated on nameplate.



Figure 3.27 - WTBX XS - Auxiliary terminal box



Figure 3.28 - WTBX S - Auxiliary terminal box

As optional, motors can be supplied with separate auxiliary terminal boxes for bearings probes and/or space heaters.



Figure 3.29 - Rib-cooled motor with separate terminal boxes for space heaters and bearings probes



Figure 3.30 - Tube-cooled motor with separate terminal boxes for space heaters and bearings probes

For additional technical information about auxiliary terminal boxes please consult Section 7 - Terminal boxes.

3.1.6.3. Terminal Boxes Arrangements

W22Xd rib-cooled range has a complete solution of adaptors for multiple position and combinations of power, neutral, protections and auxiliary terminal boxes, to meet all needs and demands. The flexibility of terminal box positions on the W22Xd ribbed motors offered by two different adaptors can be seen in figures 3.31 and 3.32.

Side mounted terminal box can be positioned on the opposite side simply by rotating the adaptor.

Some examples of terminal boxes arrangements for W22Xd rib-cooled range are shown in figures 3.31 and 3.32.



Figure 3.31 - Optional terminal boxes arrangements in rib-cooled motors



Figure 3.32 - Optional terminal boxes arrangements in rib-cooled motors

W22Xd tube-cooled range can also offer multiple position and combinations of power, neutral, protections and auxiliary terminal boxes, to meet all needs and demands.

W22Xd tube-cooled frames design allow multiple terminal box mounting positions.

Some examples of terminal boxes arrangements for W22Xd tube-cooled range are shown in figures 3.33 and 3.34.



Figure 3.33 - Optional terminal boxes arrangements in tube-cooled motors



Figure 3.36 - Ground terminals on the tube-cooled motor feet

Standard main and auxiliary terminal boxes are fitted with three ground terminals: two internally and one externally.

3



Figure 3.34 - Optional terminal boxes arrangements in tube-cooled motors



Figure 3.37 - Ground terminals in a standard main terminal box

3.1.7. Ground Terminals

W22Xd motors with feet are provided with two ground terminals on the same side of the power cable entry. In motors without feet, one ground terminal is provided on the frame, instead.

Each frame ground terminal allows the connection of an earth cable of a 25 up to 185mm².

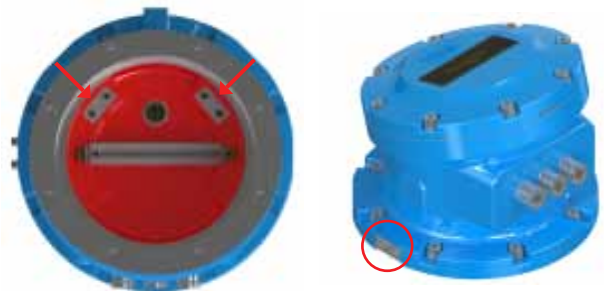

Figure 3.38 - Ground terminals in a auxiliary terminal box

Each terminal box ground terminal allows the connection of an earth cable of a 25 up to 185mm².

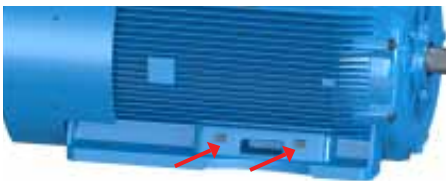

Figure 3.35 - Ground terminals on the ribbed motor feet

3.1.8. Fan Cover

3.1.8.1. Rib-Cooled Motors

The fan cover is made of fabricated steel, with an aerodynamic energy saving design, allowing a significant reduction in noise level and optimizing the air flow through frame fins for heat exchange improvement.

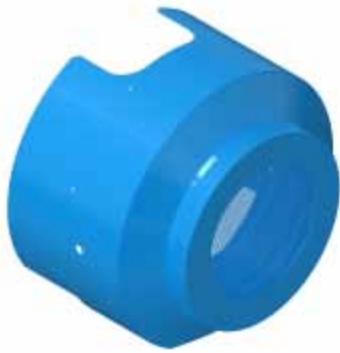

Figure 3.39 - Fan cover

3.1.8.2. Tube-Cooled Motors

The fan cover is made of fabricated steel, with an energy saving design, allowing a significant reduction in noise level, optimizing the air flow through frame tubes for heat exchange improvement. Fan covers can have axial or radial air entrance and can be equipped with sound suppressing materials for lower noise level.



Figure 3.40 - Fan cover

An air deflector can be mounted on the drive end side to reduce the noise level in the air outlet area and to remove the air flow away from the driven machine.



Figure 3.41 - Drive end air deflector

3.2. Shaft and Bearings

3.2.1. Shaft

The standard shaft material for W22Xd rib-cooled motors is AISI 4140.

The shafts for W22Xd tube-cooled motors have welded ribs or spiders and, depending on motor power and polarity, the standard material can be either S 355 J 2 G 3 (EURONORM) or AISI 4140.

All motor shafts are fitted with tapped center holes according to DIN 332 Standard, allowing an easier maintenance and coupling assembling.

The shaft dimensions are in accordance with IEC 60072 Standards (where applicable) and can be found in Section 6 - Electrical and Mechanical Data of this catalogue.

Motors with standard shaft dimensions are supplied with type "C" key as per DIN 6885. WEG can also supply, under request, motors with special shaft dimensions meeting customer requirements.

A second shaft end or/and other shaft materials can be supplied under request.

The second shaft end dimensions are shown in the Section 6 - Electrical and Mechanical Data.

3.2.2. Bearings

Horizontal motors are supplied, as standard, with anti-friction ball/roller bearings, with C3 clearance.

All grease lubricated bearings of the W22Xd line are fitted with an efficient grease system that ensures lower bearing temperature and longer lubrication intervals during motor operation.

Motors for vertical mounting are supplied with anti-friction ball bearings on drive end and non drive end sides in frames up to 355M/L. As optional, angular contact ball bearing can be provided for higher axial thrusts. For frames 355A/B and above an angular contact ball bearing is supplied on the non drive end side.

Motors with grease lubricated bearings have a standard lifetime L10h of 40.000 hours. Different bearing lifetimes can be evaluated on request.

3.2.2.1. Lubrication System

All W22Xd rib-cooled and W22Xd tube-cooled motors are supplied, as standard, with extended grease nipples, which allows the re-lubrication of the bearings with the motor running.

The standard grease outlet system is a plastic box cover, as seen in figure 3.42.

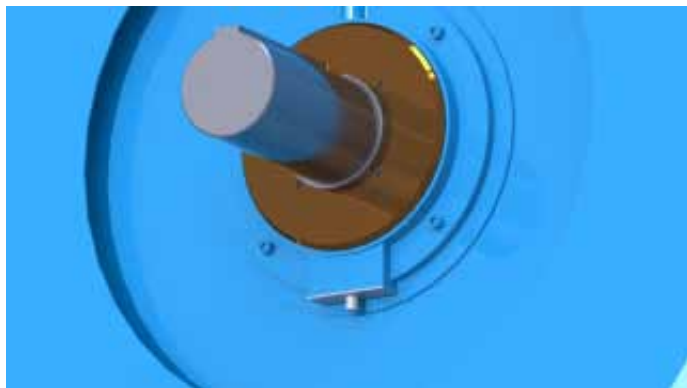

Figure 3.42 - Plastic box cover

3

As an optional feature, to safely remove the old grease without the need of either turning off the motor or to remove the fan cover, W22Xd rib and tube-cooled motors may be equipped with a special bearing cap, including an extended grease removal device (figures 3.43 and 3.44).



Figure 3.43 - Drive end grease removal device



Figure 3.44 - Non drive end grease removal device

3.2.2.2. Lubrication Intervals

The bearing lifetime depends on its type and size, the axial and radial thrusts applied to it, the environment/working conditions (temperature, cleanliness, vibrations ...), the speed and the grease type. The designed bearing lifetime can be assured by following the factory recommended grease quantity and lubrication intervals. W22Xd motors are fitted with grease nipples in the endshields for bearing lubrication. The grease quantity and lubrication intervals are specified on the nameplate and are shown on the tables 3.04, 3.05 and 3.06 for rib-cooled motors and 3.07 and 3.08 for tube-cooled motors.

It is important to emphasize that lubrication in excess might also result in an additional increase of the bearing temperature.

Table 3.03 shows the recommended greases and their main lubricating characteristics.

| Application | Standard grease (ambient temperature $\geq -30^{\circ}\text{C}$) | Compatible grease | Compatible grease | Standard for ambient temperatures $\geq -40^{\circ}\text{C}$ and $< -30^{\circ}\text{C}$ | Standard for ambient temperatures $\geq -55^{\circ}\text{C}$ and $< -40^{\circ}\text{C}$ |
|----------------------------------|---|------------------------|-----------------------|--|--|
| Grease | Mobil Polyrex EM | Shell Albida RL2 | Klüberplex BEM 41-132 | Shell Aeroshell 22 | Shell Aeroshell 7 |
| Oil Based | Mineral | Mineral | Synthetic hydrocarbon | Synthetic | Synthetic |
| Thickener | Polyrea | Lithium complex | Lithium complex | Microgel | Microgel |
| NLGI grade | 2/3 | 2 | 2 | 2 | 2 |
| Viscosity (40°C) | 115 mm ² /s | 100mm ² /s | 120mm ² /s | 30.5mm ² /s | 10.3 mm ² /s |
| Viscosity (100°C) | 12,2 mm ² /s | 11,5mm ² /s | 14mm ² /s | 5.7 mm ² /s | 3.1 mm ² /s |
| Operation Temperature | -30°C to 170°C | -20°C to 150°C | -40°C to 150°C | -65°C to 204°C | -73°C to 149°C |
| Dropping point | 270°C | 260°C | 250°C | 260°C | 260°C |
| Penetration Capacity (ASTM D217) | 250 | 265-295 | 265-295 | 275 | 296 |

Table 3.03 - Recommended greases data

Important notes:

- Operation in abnormal conditions, such as: ambient temperature, altitude, axial or radial loads above those indicated in the following tables will result in specific lubrication intervals, different from those listed here. In these cases, please contact WEG.
- The use of other greases not listed herein without WEG written authorization, will automatically cancel the warranty.
- The following tables show reference values. For accurate values please refer to the motor nameplate.
- For 2 pole motors with roller bearings, please refer to us.

| HORIZONTAL MOTORS - STANDARD | | | | | Lubrication Intervals [h] | | | | | | | |
|----------------------------------|--------|---------|----------|---------|---------------------------|---------------------------|-------------------|-------------------|---------------------------|-------------------|-------------------|------|
| Range | Frame | Poles | Bearings | | Quant. (g) | 50Hz | | | 60Hz | | | |
| | | | | | | Ambient Temperature Range | | | Ambient Temperature Range | | | |
| | | | | | | -20°C up to +40°C | -20°C up to +55°C | -55°C up to +40°C | -20°C up to +40°C | -20°C up to +55°C | -55°C up to +40°C | |
| W22Xd (rib-cooled motors) | 315L | 2P | DE | 6314 C3 | 26 | 4500 | 2300 | 4500 | 3200 | 1600 | 3200 | |
| | | | NDE | 6314 C3 | 26 | 4500 | 2300 | 4500 | 3200 | 1600 | 3200 | |
| | | 4P | DE | 6319 C3 | 45 | 4500 | 4300 | 4500 | 4500 | 3300 | 4500 | |
| | | | NDE | 6316 C3 | 33 | 4500 | 4500 | 4500 | 4500 | 4200 | 4500 | |
| | | 6P | DE | 6319 C3 | 45 | 4500 | 4500 | 4500 | 4500 | 4500 | 4500 | 4500 |
| | | | NDE | 6316 C3 | 33 | 4500 | 4500 | 4500 | 4500 | 4500 | 4500 | 4500 |
| | 8P | DE | 6319 C3 | 45 | 4500 | 4500 | 4500 | 4500 | 4500 | 4500 | 4500 | |
| | | NDE | 6316 C3 | 33 | 4500 | 4500 | 4500 | 4500 | 4500 | 4500 | 4500 | |
| | 355M/L | 2P | DE | 6316 C3 | 33 | 3600 | 1800 | 3600 | 2300 | 1100 | 2300 | |
| | | | NDE | 6316 C3 | 33 | 3600 | 1800 | 3600 | 2300 | 1100 | 2300 | |
| | | 4P | DE | 6322 C3 | 60 | 4500 | 3400 | 4500 | 4500 | 2500 | 4500 | |
| | | | NDE | 6319 C3 | 45 | 4500 | 4300 | 4500 | 4500 | 3300 | 4500 | |
| | | 6P | DE | 6322 C3 | 60 | 4500 | 4500 | 4500 | 4500 | 4300 | 4500 | |
| | | | NDE | 6319 C3 | 45 | 4500 | 4500 | 4500 | 4500 | 4500 | 4500 | |
| | 8P | DE | 6322 C3 | 60 | 4500 | 4500 | 4500 | 4500 | 4500 | 4500 | | |
| | | NDE | 6319 C3 | 45 | 4500 | 4500 | 4500 | 4500 | 4500 | 4500 | | |
| | 355A/B | 2P | DE | 6316 C3 | 33 | 3600 | 1800 | 3600 | 2300 | 1100 | 2300 | |
| | | | NDE | 6316 C3 | 33 | 3600 | 1800 | 3600 | 2300 | 1100 | 2300 | |
| | | 4P | DE | 6322 C3 | 60 | 4500 | 3400 | 4500 | 4500 | 2500 | 4500 | |
| | | | NDE | 6319 C3 | 45 | 4500 | 4300 | 4500 | 4500 | 3300 | 4500 | |
| | | 6P | DE | 6322 C3 | 60 | 4500 | 4500 | 4500 | 4500 | 4300 | 4500 | |
| | | | NDE | 6319 C3 | 45 | 4500 | 4500 | 4500 | 4500 | 4500 | 4500 | |
| | 8P | DE | 6322 C3 | 60 | 4500 | 4500 | 4500 | 4500 | 4500 | 4500 | | |
| | | NDE | 6319 C3 | 45 | 4500 | 4500 | 4500 | 4500 | 4500 | 4500 | | |
| | 400L/J | 2P | DE | 6318 C3 | 41 | 2800 | 1400 | 2800 | 1700 | 1000 | 1700 | |
| | | | NDE | 6318 C3 | 41 | 2800 | 1400 | 2800 | 1700 | 1000 | 1700 | |
| | | 4P | DE | 6324 C3 | 72 | 4500 | 3000 | 4500 | 4300 | 2100 | 4300 | |
| | | | NDE | 6324 C3 | 72 | 4500 | 3000 | 4500 | 4300 | 2100 | 4300 | |
| | | 6P | DE | 6324 C3 | 72 | 4500 | 4500 | 4500 | 4500 | 3900 | 4500 | |
| | | | NDE | 6324 C3 | 72 | 4500 | 4500 | 4500 | 4500 | 3900 | 4500 | |
| | 8P | DE | 6324 C3 | 72 | 4500 | 4500 | 4500 | 4500 | 4500 | 4500 | | |
| | | NDE | 6324 C3 | 72 | 4500 | 4500 | 4500 | 4500 | 4500 | 4500 | | |
| | 400G | 2P | DE | 6318 C3 | 41 | 2800 | 1400 | 2800 | 1700 | 1000 | 1700 | |
| | | | NDE | 6318 C3 | 41 | 2800 | 1400 | 2800 | 1700 | 1000 | 1700 | |
| | | 4P | DE | 6324 C3 | 72 | 4500 | 3000 | 4500 | 4300 | 2100 | 4300 | |
| | | | NDE | 6324 C3 | 72 | 4500 | 3000 | 4500 | 4300 | 2100 | 4300 | |
| 6P | | DE | 6324 C3 | 72 | 4500 | 4500 | 4500 | 4500 | 3900 | 4500 | | |
| | | NDE | 6324 C3 | 72 | 4500 | 4500 | 4500 | 4500 | 3900 | 4500 | | |
| 8P | DE | 6324 C3 | 72 | 4500 | 4500 | 4500 | 4500 | 4500 | 4500 | | | |
| | NDE | 6324 C3 | 72 | 4500 | 4500 | 4500 | 4500 | 4500 | 4500 | | | |



| HORIZONTAL MOTORS - STANDARD | | | | | | Lubrication Intervals [h] | | | | | | |
|------------------------------|-------------------|--------|-------------------|------------------|--------------------|---------------------------|-------------------|-------------------|---------------------------|-------------------|-------------------|------|
| Range | Frame | Poles | Bearings | | Quant. (g) | 50Hz | | | 60Hz | | | |
| | | | | | | Ambient Temperature Range | | | Ambient Temperature Range | | | |
| | | | | | | -20°C up to +40°C | -20°C up to +55°C | -55°C up to +40°C | -20°C up to +40°C | -20°C up to +55°C | -55°C up to +40°C | |
| W22Xd (rib-cooled motors) | 450K/H | 2P | DE | 6318 C3 | 41 | 2800 | 1400 | 2800 | 1700 | 1000 | 1700 | |
| | | | NDE | NU218 C3 | 24 | 1200 | 1000 | 1200 | 4500 | 3000 | 4500 | |
| | | 4P | DE | 6326 C3 | 81 | 4500 | 2600 | 4500 | 3700 | 1800 | 3700 | |
| | | | NDE | 6326 C3 | 81 | 4500 | 2600 | 4500 | 3700 | 1800 | 3700 | |
| | | 6P | DE | 6326 C3 | 81 | 4500 | 4100 | 4500 | 4500 | 3500 | 4500 | |
| | | | NDE | 6326 C3 | 81 | 4500 | 4100 | 4500 | 4500 | 3500 | 4500 | |
| | | 8P | DE | 6326 C3 | 81 | 4500 | 4500 | 4500 | 4500 | 4500 | 4500 | |
| | | | NDE | 6326 C3 | 81 | 4500 | 4500 | 4500 | 4500 | 4500 | 4500 | |
| | | 500K/H | 2P | DE | NU220 C3 + 6020 C3 | 31+18 | 1000 | 1000 | 1000 | - | - | - |
| | | | | NDE | NU220 C3 | 31 | 1000 | 1000 | 1000 | - | - | - |
| | | | 4P ⁽¹⁾ | DE | 6328 C3 | 93 | 4500 | 2300 | 4500 | 3200 | 1600 | 3200 |
| | | | | NDE | 6328 C3 | 93 | 4500 | 2300 | 4500 | 3200 | 1600 | 3200 |
| | 6P ⁽¹⁾ | | DE | 6328 C3 | 93 | 4500 | 3800 | 4500 | 4500 | 3200 | 4500 | |
| | | | NDE | 6328 C3 | 93 | 4500 | 3800 | 4500 | 4500 | 3200 | 4500 | |
| | 8P ⁽¹⁾ | | DE | 6328 C3 | 93 | 4500 | 4500 | 4500 | 4500 | 4100 | 4500 | |
| | | | NDE | 6328 C3 | 93 | 4500 | 4500 | 4500 | 4500 | 4100 | 4500 | |
| | 560H/G | | 2P | DE/NDE | OR | OR | OR | OR | OR | - | - | - |
| | | | | DE | NU328 C3+6328 C3 | 93+93 | 1400 | 1000 | 1400 | 1000 | 1000 | 1000 |
| | | | 4P | NDE | NU328 C3 | 93 | 1400 | 1000 | 1400 | 1000 | 1000 | 1000 |
| | | | | DE | NU328 C3+6328 C3 | 93+93 | 3000 | 1500 | 3000 | 2200 | 1100 | 2200 |
| | | 6P | NDE | NU328 C3 | 93 | 3000 | 1500 | 3000 | 2200 | 1100 | 2200 | |
| | | | DE | NU328 C3+6328 C3 | 93+93 | 4400 | 2200 | 4400 | 3500 | 1700 | 3500 | |
| | | 8P | NDE | NU328 C3 | 93 | 4400 | 2200 | 4400 | 3500 | 1700 | 3500 | |

(1) The highest rated outputs might require special bearing arrangements
OR - On Request

Table 3.04 - Lubrication intervals and grease quantity for standard horizontal ribbed motors

As an option, horizontal motors can be equipped with roller bearings. Lubrication values are in the following table.

| HORIZONTAL MOTORS - OPTIONAL | | | | | | Lubrication Intervals [h] | | | | | | |
|------------------------------|-------|--------|----------|----------|------------|---------------------------|-------------------|-------------------|---------------------------|-------------------|-------------------|------|
| Range | Frame | Poles | Bearings | | Quant. (g) | 50Hz | | | 60Hz | | | |
| | | | | | | Ambient Temperature Range | | | Ambient Temperature Range | | | |
| | | | | | | -20°C up to +40°C | -20°C up to +55°C | -55°C up to +40°C | -20°C up to +40°C | -20°C up to +55°C | -55°C up to +40°C | |
| W22Xd (rib-cooled motors) | 315L | 4P | DE | NU319 C3 | 45 | 3500 | 1700 | 3500 | 2500 | 1200 | 2500 | |
| | | | NDE | 6316 C3 | 33 | 4500 | 4500 | 4500 | 4500 | 4200 | 4500 | |
| | | 6P | DE | NU319 C3 | 45 | 4500 | 2800 | 4500 | 4500 | 2300 | 4500 | |
| | | | NDE | 6316 C3 | 33 | 4500 | 3400 | 4500 | 4500 | 4500 | 4500 | |
| | | 8P | DE | NU319 C3 | 45 | 4500 | 3500 | 4500 | 4500 | 3100 | 4500 | |
| | | | NDE | 6316 C3 | 33 | 4500 | 4000 | 4500 | 4500 | 4500 | 4500 | |
| | | 355M/L | 4P | DE | NU322 C3 | 60 | 2400 | 1200 | 2400 | 1600 | 1000 | 1600 |
| | | | | NDE | 6319 C3 | 45 | 4500 | 4300 | 4500 | 4500 | 3300 | 4500 |
| | 6P | | DE | NU322 C3 | 60 | 4500 | 2200 | 4500 | 3500 | 1700 | 3500 | |
| | | | NDE | 6319 C3 | 45 | 4500 | 4500 | 4500 | 4500 | 4500 | 4500 | |
| | 8P | | DE | NU322 C3 | 60 | 4500 | 2900 | 4500 | 4500 | 4000 | 4500 | |
| | | | NDE | 6319 C3 | 45 | 4500 | 4500 | 4500 | 4500 | 4500 | 4500 | |

| HORIZONTAL MOTORS - OPTIONAL | | | | | Lubrication Intervals [h] | | | | | | |
|------------------------------|--------|-------------------|------------------|----------|---------------------------|---------------------------|-------------------|-------------------|---------------------------|-------------------|-------------------|
| Range | Frame | Poles | Bearings | | Quant. (g) | 50Hz | | | 60Hz | | |
| | | | | | | Ambient Temperature Range | | | Ambient Temperature Range | | |
| | | | | | | -20°C up to +40°C | -20°C up to +55°C | -55°C up to +40°C | -20°C up to +40°C | -20°C up to +55°C | -55°C up to +40°C |
| W22Xd (rib-cooled motors) | 355A/B | 4P | DE | NU322 C3 | 60 | 2400 | 1200 | 2400 | 1600 | 1000 | 1600 |
| | | | NDE | 6319 C3 | 45 | 4500 | 4300 | 4500 | 4500 | 3300 | 4500 |
| | | 6P | DE | NU322 C3 | 60 | 4500 | 2200 | 4500 | 3500 | 1700 | 3500 |
| | | | NDE | 6319 C3 | 45 | 4500 | 4500 | 4500 | 4500 | 4500 | 4500 |
| | | 8P | DE | NU322 C3 | 60 | 4500 | 2900 | 4500 | 4500 | 4000 | 4500 |
| | | | NDE | 6319 C3 | 45 | 4500 | 4500 | 4500 | 4500 | 4500 | 4500 |
| | 400L/J | 4P | DE | NU324 C3 | 72 | 2000 | 1000 | 2000 | 1300 | 1000 | 1300 |
| | | | NDE | 6324 C3 | 72 | 4500 | 3000 | 4500 | 4300 | 2100 | 4300 |
| | | 6P | DE | NU324 C3 | 72 | 3900 | 1900 | 3900 | 3000 | 1500 | 3000 |
| | | | NDE | 6324 C3 | 72 | 4500 | 4500 | 4500 | 4500 | 3900 | 4500 |
| | | 8P | DE | NU324 C3 | 72 | 4500 | 2600 | 4500 | 4500 | 2200 | 4500 |
| | | | NDE | 6324 C3 | 72 | 4500 | 4500 | 4500 | 4500 | 4500 | 4500 |
| | 400G | 4P | DE | NU324 C3 | 72 | 2000 | 1000 | 2000 | 1500 | 1000 | 1500 |
| | | | NDE | 6324 C3 | 72 | 4500 | 3000 | 4500 | 4300 | 2100 | 4300 |
| | | 6P | DE | NU324 C3 | 72 | 3900 | 1900 | 3900 | 3000 | 1500 | 3000 |
| | | | NDE | 6324 C3 | 72 | 4500 | 4500 | 4500 | 4500 | 3900 | 4500 |
| | | 8P | DE | NU324 C3 | 72 | 4500 | 2600 | 4500 | 4500 | 2200 | 4500 |
| | | | NDE | 6324 C3 | 72 | 4500 | 4500 | 4500 | 4500 | 4500 | 4500 |
| | 450K/H | 4P | DE | NU326 C3 | 81 | 1700 | 1000 | 1700 | 1000 | 1000 | 1000 |
| | | | NDE | 6326 C3 | 81 | 4500 | 2600 | 4500 | 3700 | 1800 | 3700 |
| | | 6P | DE | NU326 C3 | 81 | 3500 | 1700 | 3500 | 2600 | 1300 | 2600 |
| | | | NDE | 6326 C3 | 81 | 4500 | 4100 | 4500 | 4500 | 3500 | 4500 |
| | | 8P | DE | NU326 C3 | 81 | 4500 | 2400 | 4500 | 4000 | 2000 | 4000 |
| | | | NDE | 6326 C3 | 81 | 4500 | 4500 | 4500 | 4500 | 4500 | 4500 |
| | 500K/H | 4P ⁽¹⁾ | DE | NU328 C3 | 93 | 1400 | 1000 | 1400 | 1000 | 1000 | 1000 |
| | | | NDE | 6328 C3 | 93 | 4500 | 2300 | 4500 | 3200 | 1600 | 3200 |
| | | 6P ⁽¹⁾ | DE | NU328 C3 | 93 | 3000 | 1500 | 3000 | 2200 | 1100 | 2200 |
| | | | NDE | 6328 C3 | 93 | 4500 | 3800 | 4500 | 4500 | 3200 | 4500 |
| 8P ⁽¹⁾ | | DE | NU328 C3 | 93 | 4400 | 2200 | 4400 | 3500 | 1700 | 3500 | |
| | | NDE | 6328 C3 | 93 | 4500 | 4500 | 4500 | 4500 | 4100 | 4500 | |
| 560H/G | 4P | DE | NU328 C3+6328 C3 | 93+93 | 1400 | 1000 | 1400 | 1000 | 1000 | 1000 | |
| | | NDE | NU328 C3 | 93 | 1400 | 1000 | 1400 | 1000 | 1000 | 1000 | |
| | 6P | DE | NU328 C3+6328 C3 | 93+93 | 3000 | 1500 | 3000 | 2200 | 1100 | 2200 | |
| | | NDE | NU328 C3 | 93 | 3000 | 1500 | 3000 | 2200 | 1100 | 2200 | |
| | 8P | DE | NU328 C3+6328 C3 | 93+93 | 4400 | 2200 | 4400 | 3500 | 1700 | 3500 | |
| | | NDE | NU328 C3 | 93 | 4400 | 2200 | 4400 | 3500 | 1700 | 3500 | |

(1) The highest rated outputs might require special bearing arrangements

Table 3.05 - Lubrication intervals and grease quantity for horizontal ribbed motors with roller bearings in DE side

For vertical motors, the values for lubrication are shown in the following table.

| VERTICAL MOTORS - STANDARD | | | | | | Lubrication Intervals [h] | | | | | |
|----------------------------------|--------|---------|----------|---------|---------------|---------------------------|-------------------|-------------------|---------------------------|-------------------|-------------------|
| Range | Frame | Poles | Bearings | | Quant. (g) | 50Hz | | | 60Hz | | |
| | | | | | | Ambient Temperature Range | | | Ambient Temperature Range | | |
| | | | | | | -20°C up to +40°C | -20°C up to +55°C | -55°C up to +40°C | -20°C up to +40°C | -20°C up to +55°C | -55°C up to +40°C |
| W22Xd (rib-cooled motors) | 315L | 2P | DE | 6314 C3 | 26 | 2300 | 1100 | 2300 | 1600 | 1000 | 1600 |
| | | | NDE | 6314 C3 | 26 | 2300 | 1100 | 2300 | 1600 | 1000 | 1600 |
| | | 4P | DE | 6319 C3 | 45 | 4300 | 2100 | 4300 | 3300 | 1600 | 3300 |
| | | | NDE | 6316 C3 | 33 | 4500 | 2600 | 4500 | 4200 | 2100 | 4200 |
| | | 6P | DE | 6319 C3 | 45 | 4500 | 2800 | 4500 | 4500 | 2600 | 4500 |
| | | | NDE | 6316 C3 | 33 | 4500 | 3200 | 4500 | 4500 | 3000 | 4500 |
| | 8P | DE | 6319 C3 | 45 | 4500 | 3100 | 4500 | 4500 | 3000 | 4500 | |
| | | NDE | 6316 C3 | 33 | 4500 | 3500 | 4500 | 4500 | 3300 | 4500 | |
| | 355M/L | 2P | DE | 6316 C3 | 33 | 1800 | 1000 | 1800 | 1100 | 1000 | 1100 |
| | | | NDE | 6316 C3 | 33 | 1800 | 1000 | 1800 | 1100 | 1000 | 1100 |
| | | 4P | DE | 6322 C3 | 60 | 3400 | 1700 | 3400 | 2500 | 1200 | 2500 |
| | | | NDE | 6319 C3 | 45 | 4300 | 2100 | 4300 | 3300 | 1600 | 3300 |
| | | 6P | DE | 6322 C3 | 60 | 4500 | 2400 | 4500 | 4300 | 2100 | 4300 |
| | | | NDE | 6319 C3 | 45 | 4500 | 2800 | 4500 | 4500 | 2600 | 4500 |
| | 8P | DE | 6322 C3 | 60 | 4500 | 2800 | 4500 | 4500 | 2600 | 4500 | |
| | | NDE | 6319 C3 | 45 | 4500 | 3100 | 4500 | 4500 | 3000 | 4500 | |
| | 355A/B | 2P | DE | 6316 C3 | 33 | 1800 | 1000 | 1800 | 1100 | 1000 | 1100 |
| | | | NDE | 7316 | 33 | 1800 | 1000 | 1800 | 1100 | 1000 | 1100 |
| | | 4P | DE | 6322 C3 | 60 | 3400 | 1700 | 3400 | 2500 | 1200 | 2500 |
| | | | NDE | 7319 | 45 | 4300 | 2100 | 4300 | 3300 | 1600 | 3300 |
| | | 6P | DE | 6322 C3 | 60 | 4500 | 2400 | 4500 | 4300 | 2100 | 4300 |
| | | | NDE | 7319 | 45 | 4500 | 2800 | 4500 | 4500 | 2600 | 4500 |
| | 8P | DE | 6322 C3 | 60 | 4500 | 2800 | 4500 | 4500 | 2600 | 4500 | |
| | | NDE | 7319 | 45 | 4500 | 3100 | 4500 | 4500 | 3000 | 4500 | |
| 400L/J | 2P | DE | 6318 C3 | 41 | 1400 | 1000 | 1400 | 1000 | 1000 | 1000 | |
| | | NDE | 7318 | 41 | 1400 | 1000 | 1400 | 1000 | 1000 | 1000 | |
| | 4P | DE | 6324 C3 | 72 | 3000 | 1500 | 3000 | 2100 | 1000 | 2100 | |
| | | NDE | 7324 | 72 | 3000 | 1500 | 3000 | 2100 | 1000 | 2100 | |
| | 6P | DE | 6324 C3 | 72 | 4500 | 2200 | 4500 | 3900 | 1900 | 3900 | |
| | | NDE | 7324 | 72 | 4500 | 2200 | 4500 | 3900 | 1900 | 3900 | |
| 8P | DE | 6324 C3 | 72 | 4500 | 2600 | 4500 | 4500 | 2400 | 4500 | | |
| | NDE | 7324 | 72 | 4500 | 2600 | 4500 | 4500 | 2400 | 4500 | | |
| 400G | 2P | DE | 6318 C3 | 41 | 1400 | 1000 | 1400 | 1000 | 1000 | 1000 | |
| | | NDE | 7318 | 41 | 1400 | 1000 | 1400 | 1000 | 1000 | 1000 | |
| | 4P | DE | 6324 C3 | 72 | 3000 | 1500 | 3000 | 2100 | 1000 | 2100 | |
| | | NDE | 7324 | 72 | 3000 | 1500 | 3000 | 2100 | 1000 | 2100 | |
| | 6P | DE | 6324 C3 | 72 | 4500 | 2200 | 4500 | 3900 | 1900 | 3900 | |
| | | NDE | 7324 | 72 | 4500 | 2200 | 4500 | 3900 | 1900 | 3900 | |
| 8P | DE | 6324 C3 | 72 | 4500 | 2600 | 4500 | 4500 | 2400 | 4500 | | |
| | NDE | 7324 | 72 | 4500 | 2600 | 4500 | 4500 | 2400 | 4500 | | |

| VERTICAL MOTORS - STANDARD | | | | | Lubrication Intervals [h] | | | | | | |
|----------------------------------|--------|-------|----------|---------|---------------------------|---------------------------|-------------------|-------------------|---------------------------|-------------------|-------------------|
| Range | Frame | Poles | Bearings | | Quant. (g) | 50Hz | | | 60Hz | | |
| | | | | | | Ambient Temperature Range | | | Ambient Temperature Range | | |
| | | | | | | -20°C up to +40°C | -20°C up to +55°C | -55°C up to +40°C | -20°C up to +40°C | -20°C up to +55°C | -55°C up to +40°C |
| W22Xd (rib-cooled motors) | 450K/H | 4P | DE | 6326 C3 | 81 | 2600 | 1300 | 2600 | 1800 | 1000 | 1800 |
| | | | NDE | 7326 | 81 | 2600 | 1300 | 2600 | 1800 | 1000 | 1800 |
| | | 6P | DE | 6326 C3 | 81 | 4100 | 2000 | 4100 | 3500 | 1700 | 3500 |
| | | | NDE | 7326 | 81 | 4100 | 2000 | 4100 | 3500 | 1700 | 3500 |
| | | 8P | DE | 6326 C3 | 81 | 4500 | 2500 | 4500 | 4500 | 2200 | 4500 |
| | | | NDE | 7326 | 81 | 4500 | 2500 | 4500 | 4500 | 2200 | 4500 |
| | 500K/H | 4P | DE | 6328 C3 | 93 | 2300 | 1100 | 2300 | 1600 | 1000 | 1600 |
| | | | NDE | 7328 | 93 | 2300 | 1100 | 2300 | 1600 | 1000 | 1600 |
| | | 6P | DE | 6328 C3 | 93 | 3800 | 1900 | 3800 | 3200 | 1600 | 3200 |
| | | | NDE | 7328 | 93 | 3800 | 1900 | 3800 | 3200 | 1600 | 3200 |
| | | 8P | DE | 6328 C3 | 93 | 4500 | 2300 | 4500 | 4100 | 2000 | 4100 |
| | | | NDE | 7328 | 93 | 4500 | 2300 | 4500 | 4100 | 2000 | 4100 |
| | 560H/G | 4P | DE | 6328 C3 | 93 | 2300 | 1100 | 2300 | 1600 | 1000 | 1600 |
| | | | NDE | 7328 | 93 | 2300 | 1100 | 2300 | 1600 | 1000 | 1600 |
| | | 6P | DE | 6328 C3 | 93 | 3800 | 1900 | 3800 | 3200 | 1600 | 3200 |
| | | | NDE | 7328 | 93 | 3800 | 1900 | 3800 | 3200 | 1600 | 3200 |
| | | 8P | DE | 6328 C3 | 93 | 4500 | 2300 | 4500 | 4100 | 2000 | 4100 |
| | | | NDE | 7328 | 93 | 4500 | 2300 | 4500 | 4100 | 2000 | 4100 |

Table 3.06 - Lubrication intervals and grease quantity for standard vertical ribbed motors



| HORIZONTAL MOTORS - STANDARD | | | | | | Lubrication Intervals [h] | | | | | |
|------------------------------|--------|---------|------------------|------------------|------------|---------------------------|-------------------|-------------------|---------------------------|-------------------|-------------------|
| Range | Frame | Poles | Bearings | | Quant. (g) | 50Hz | | | 60Hz | | |
| | | | | | | Ambient Temperature Range | | | Ambient Temperature Range | | |
| | | | | | | -20°C up to +40°C | -20°C up to +55°C | -55°C up to +40°C | -20°C up to +40°C | -20°C up to +55°C | -55°C up to +40°C |
| W22Xd (tube-cooled motors) | 560J/H | 2P | DE | NU220 C3+6020 C3 | 31+18 | 1000 | 1000 | 1000 | - | - | - |
| | | | NDE | NU220 C3 | 31 | 1000 | 1000 | 1000 | - | - | - |
| | | 4P | DE | 6330 C3 | 104 | 4100 | 2000 | 4100 | 2700 | 1300 | 2700 |
| | | | NDE | 6330 C3 | 104 | 4100 | 2000 | 4100 | 2700 | 1300 | 2700 |
| | | 6P | DE | 6330 C3 | 104 | 4500 | 3500 | 4500 | 4500 | 2800 | 4500 |
| | | | NDE | 6330 C3 | 104 | 4500 | 3500 | 4500 | 4500 | 2800 | 4500 |
| | 8P | DE | 6330 C3 | 104 | 4500 | 4400 | 4500 | 4500 | 3800 | 4500 | |
| | | NDE | 6330 C3 | 104 | 4500 | 4400 | 4500 | 4500 | 3800 | 4500 | |
| | 560H/G | 2P | DE | NU220 C3+6020 C3 | 31+18 | 1000 | 1000 | 1000 | - | - | - |
| | | | NDE | NU220 C3 | 31 | 1000 | 1000 | 1000 | - | - | - |
| | | 4P | DE | 6330 C3 | 104 | 4100 | 2000 | 4100 | 2700 | 1300 | 2700 |
| | | | NDE | 6330 C3 | 104 | 4100 | 2000 | 4100 | 2700 | 1300 | 2700 |
| | | 6P | DE | 6330 C3 | 104 | 4500 | 3500 | 4500 | 4500 | 2800 | 4500 |
| | | | NDE | 6330 C3 | 104 | 4500 | 3500 | 4500 | 4500 | 2800 | 4500 |
| | 8P | DE | 6330 C3 | 104 | 4500 | 4400 | 4500 | 4500 | 3800 | 4500 | |
| | | NDE | 6330 C3 | 104 | 4500 | 4400 | 4500 | 4500 | 3800 | 4500 | |
| | 630K/J | 2P | DE | NU220+6020 | 31+18 | 1000 | 1000 | 1000 | - | - | - |
| | | | NDE | NU220 C3 | 31 | 1000 | 1000 | 1000 | - | - | - |
| | | 4P | DE | 6332 C3 | 116 | 3600 | 1800 | 3600 | 2300 | 1100 | 2300 |
| | | | NDE | 6332 C3 | 116 | 3600 | 1800 | 3600 | 2300 | 1100 | 2300 |
| | | 6P | DE | 6332 C3 | 116 | 4500 | 3200 | 4500 | 4500 | 2600 | 4500 |
| | | | NDE | 6332 C3 | 116 | 4500 | 3200 | 4500 | 4500 | 2600 | 4500 |
| | 8P | DE | 6332 C3 | 116 | 4500 | 4100 | 4500 | 4500 | 3500 | 4500 | |
| | | NDE | 6332 C3 | 116 | 4500 | 4100 | 4500 | 4500 | 3500 | 4500 | |
| | 630J/H | 2P | DE | NU220+6020 | 31+18 | 1000 | 1000 | 1000 | - | - | - |
| | | | NDE | NU220 C3 | 31 | 1000 | 1000 | 1000 | - | - | - |
| | | 4P | DE | 6332 C3 | 116 | 3600 | 1800 | 3600 | 2300 | 1100 | 2300 |
| | | | NDE | 6332 C3 | 116 | 3600 | 1800 | 3600 | 2300 | 1100 | 2300 |
| 6P | | DE | 6332 C3 | 116 | 4500 | 3200 | 4500 | 4500 | 2600 | 4500 | |
| | | NDE | 6332 C3 | 116 | 4500 | 3200 | 4500 | 4500 | 2600 | 4500 | |
| 8P | DE | 6332 C3 | 116 | 4500 | 4100 | 4500 | 4500 | 3500 | 4500 | | |
| | NDE | 6332 C3 | 116 | 4500 | 4100 | 4500 | 4500 | 3500 | 4500 | | |
| 710K/J | 2P | DE | NU220 C3+6020 C3 | 31+18 | 1000 | 1000 | 1000 | - | - | - | |
| | | NDE | NU220 C3 | 31 | 1000 | 1000 | 1000 | - | - | - | |
| 710J/H | 4P | DE | NU234 C3+6034 C3 | 81+55 | 1000 | 1000 | 1000 | 1000 | 1000 | 1000 | |
| | | NDE | NU326 C3 | 81 | 1700 | 1000 | 1700 | 1000 | 1000 | 1000 | |
| | 6P | DE | NU234 C3+6034 C3 | 81+55 | 2600 | 1300 | 2600 | 1800 | 1000 | 1800 | |
| | | NDE | NU326 C3 | 81 | 3500 | 1700 | 3500 | 2600 | 1300 | 2600 | |
| | 8P | DE | NU234 C3+6034 C3 | 81+55 | 3900 | 1900 | 3900 | 3000 | 1500 | 3000 | |
| | | NDE | NU326 C3 | 81 | 4500 | 2400 | 4500 | 4000 | 2000 | 4000 | |
| 710H/G | 4P | DE | NU238 C3+6038 C3 | 94+68 | 1000 | 1000 | 1000 | 1000 | 1000 | 1000 | |
| | | NDE | NU326 C3 | 81 | 1700 | 1000 | 1700 | 1000 | 1000 | 1000 | |
| | 6P | DE | NU238 C3+6038 C3 | 94+68 | 2100 | 1000 | 2100 | 1400 | 1000 | 1400 | |
| | | NDE | NU326 C3 | 81 | 3500 | 1700 | 3500 | 2600 | 1300 | 2600 | |
| | 8P | DE | NU238 C3+6038 C3 | 94+68 | 3300 | 1600 | 3300 | 2500 | 1200 | 2500 | |
| | | NDE | NU326 C3 | 81 | 4500 | 2400 | 4500 | 4000 | 2000 | 4000 | |

Table 3.07 - Lubrication intervals and grease quantity for standard horizontal tube-cooled motors

For vertical motors, the values for relubrication are shown in the following table.

| VERTICAL MOTORS - STANDARD | | | | | | Lubrication Intervals [h] | | | | | |
|----------------------------|--------|-------|----------|---------|---------------|---------------------------|-------------------|-------------------|---------------------------|-------------------|-------------------|
| Range | Frame | Poles | Bearings | | Quant. (g) | 50Hz | | | 60Hz | | |
| | | | | | | Ambient Temperature Range | | | Ambient Temperature Range | | |
| | | | | | | -20°C up to +40°C | -20°C up to +55°C | -55°C up to +40°C | -20°C up to +40°C | -20°C up to +55°C | -55°C up to +40°C |
| W22Xd (tube-cooled motors) | 560J/H | 4P | DE | 6330 C3 | 104 | 4100 | 2000 | 4100 | 2700 | 1300 | 2700 |
| | | | NDE | 7328 | 93 | 4500 | 2300 | 4500 | 3200 | 1600 | 3200 |
| | | 6P | DE | 6330 C3 | 104 | 4500 | 3500 | 4500 | 4500 | 2800 | 4500 |
| | | | NDE | 7328 | 93 | 4500 | 3800 | 4500 | 4500 | 3200 | 4500 |
| | | 8P | DE | 6330 C3 | 104 | 4500 | 4400 | 4500 | 4500 | 3800 | 4500 |
| | | | NDE | 7328 | 93 | 4500 | 4500 | 4500 | 4500 | 4100 | 4500 |
| | 560H/G | 4P | DE | 6330 C3 | 104 | 4100 | 2000 | 4100 | 2700 | 1300 | 2700 |
| | | | NDE | 7328 | 93 | 4500 | 2300 | 4500 | 3200 | 1600 | 3200 |
| | | 6P | DE | 6330 C3 | 104 | 4500 | 3500 | 4500 | 4500 | 2800 | 4500 |
| | | | NDE | 7328 | 93 | 4500 | 3800 | 4500 | 4500 | 3200 | 4500 |
| | | 8P | DE | 6330 C3 | 104 | 4500 | 4400 | 4500 | 4500 | 3800 | 4500 |
| | | | NDE | 7328 | 93 | 4500 | 4500 | 4500 | 4500 | 4100 | 4500 |
| | 630K/J | 4P | DE | 6332 C3 | 116 | 3600 | 1800 | 3600 | 2300 | 1100 | 2300 |
| | | | NDE | 7332 | 116 | 3600 | 1800 | 3600 | 2300 | 1100 | 2300 |
| | | 6P | DE | 6332 C3 | 116 | 4500 | 3200 | 4500 | 4500 | 2600 | 4500 |
| | | | NDE | 7332 | 116 | 4500 | 3200 | 4500 | 4500 | 2600 | 4500 |
| | | 8P | DE | 6332 C3 | 116 | 4500 | 4100 | 4500 | 4500 | 3500 | 4500 |
| | | | NDE | 7332 | 116 | 4500 | 4100 | 4500 | 4500 | 3500 | 4500 |
| | 630J/H | 4P | DE | 6332 C3 | 116 | 3600 | 1800 | 3600 | 2300 | 1100 | 2300 |
| | | | NDE | 7332 | 116 | 3600 | 1800 | 3600 | 2300 | 1100 | 2300 |
| | | 6P | DE | 6332 C3 | 116 | 4500 | 3200 | 4500 | 4500 | 2600 | 4500 |
| | | | NDE | 7332 | 116 | 4500 | 3200 | 4500 | 4500 | 2600 | 4500 |
| | | 8P | DE | 6332 C3 | 116 | 4500 | 4100 | 4500 | 4500 | 3500 | 4500 |
| | | | NDE | 7332 | 116 | 4500 | 4100 | 4500 | 4500 | 3500 | 4500 |
| 710J/H | 4P | DE | 6234 C3 | 81 | 3900 | 1900 | 3900 | 2600 | 1300 | 2600 | |
| | | NDE | 7234 | 81 | 3900 | 1900 | 3900 | 2600 | 1300 | 2600 | |
| | 6P | DE | 6234 C3 | 81 | 4500 | 3400 | 4500 | 4500 | 2800 | 4500 | |
| | | NDE | 7234 | 81 | 4500 | 3400 | 4500 | 4500 | 2800 | 4500 | |
| | 8P | DE | 6234 C3 | 81 | 4500 | 4300 | 4500 | 4500 | 3700 | 4500 | |
| | | NDE | 7234 | 81 | 4500 | 4300 | 4500 | 4500 | 3700 | 4500 | |
| 710H/G | 4P | DE | 6238 C3 | 81 | 3200 | 1600 | 3200 | 2000 | 1000 | 2000 | |
| | | NDE | 7234 | 81 | 3900 | 1900 | 3900 | 2600 | 1300 | 2600 | |
| | 6P | DE | 6238 C3 | 81 | 4500 | 2900 | 4500 | 4500 | 2300 | 4500 | |
| | | NDE | 7234 | 81 | 4500 | 3400 | 4500 | 4500 | 2800 | 4500 | |
| | 8P | DE | 6238 C3 | 81 | 4500 | 3800 | 4500 | 4500 | 3300 | 4500 | |
| | | NDE | 7234 | 81 | 4500 | 4300 | 4500 | 4500 | 3700 | 4500 | |

Table 3.08 - Lubrication intervals and grease quantity for standard vertical tube-cooled motors

For motors working in ambient temperatures between -20°C and +60°C, a derating factor of 0.8 must be applied to the values shown in column “-20°C up to +55°C”.

3.2.2.3. Permissible Thrusts

The maximum applicable radial and axial thrusts for the standard configurations are shown in the tables 3.09, 3.10 and 3.11 for rib-cooled motors.

The maximum indicated radial thrust values consider axial thrust as zero. In the same way, the maximum indicated axial thrust values consider radial thrust as zero.

For combined axial and radial thrusts or higher thrust values please refer to us.

For W22Xd tube-cooled motors with radial or axial thrusts, please refer to us.

Radial Thrusts - Horizontal Mounting

The values of permissible radial thrusts applied in the extreme of the drive end shaft ($x=E$) and in the middle of drive end shaft ($x=E/2$), are shown on the tables 3.09 and 3.10 for rib-cooled motors (figure 3.42).

The presented maximum radial thrust values consider:

- Normal operation conditions at 50Hz;
- Standard shaft material;
- Pulley-belt drive for most common applications (except for heavy impact machines).

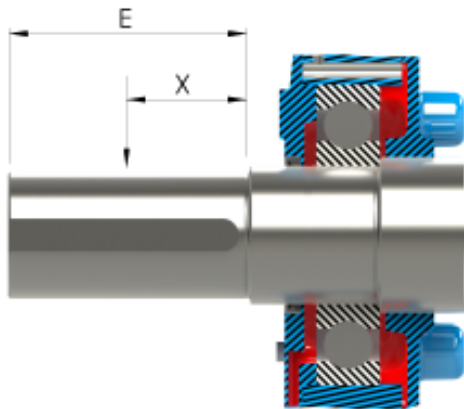

Figure 3.45 - Radial thrust application point in the middle of drive end shaft

| Permissible Radial Thrust [kN] | | | | | | |
|--------------------------------|--------|-------|--------------|--------|-------------------|---------|
| Range | Frame | Poles | Bearings | | Application point | |
| | | | D.E. | N.D.E. | $x=E$ | $x=E/2$ |
| W22Xd (rib-cooled motors) | 355A/B | 2P | 6316 | 6316 | 1.8 | 1.9 |
| | | 4P | 6322 | 6319 | 1.9 | 2 |
| | | 6P | 6322 | 6319 | 1.9 | 2 |
| | | 8P | 6322 | 6319 | 2.6 | 2.8 |
| | 400L/J | 2P | 6318 | 6318 | 1 | 1.2 |
| | | 4P | 6324 | 6324 | 1.8 | 2 |
| | | 6P | 6324 | 6324 | 2.4 | 2.6 |
| | | 8P | 6324 | 6324 | 2.7 | 2.9 |
| | 400G | 2P | 6318 | 6318 | On Request | |
| | | 4P | 6324 | 6324 | | |
| | | 6P | 6324 | 6324 | | |
| | | 8P | 6324 | 6324 | | |
| | 450K/H | 2P | 6318 | NU218 | | |
| | | 4P | 6326 | 6326 | | |
| | | 6P | 6326 | 6326 | | |
| | | 8P | 6326 | 6326 | | |
| | 500K/H | 2P | NU220 + 6020 | NU220 | | |
| | | 4P | 6328 | 6328 | | |
| | | 6P | 6328 | 6328 | | |
| | | 8P | 6328 | 6328 | | |
| | 560H/G | 4P | NU328 + 6328 | NU328 | | |
| | | 6P | NU328 + 6328 | NU328 | | |
| | | 8P | NU328 + 6328 | NU328 | | |

Table 3.09 - Permissible radial thrust for ball bearings in rib-cooled motors

| Permissible Radial Thrust [kN] | | | | | | |
|--------------------------------|--------|-------|----------|--------|-------------------|---------|
| Range | Frame | Poles | Bearings | | Application point | |
| | | | D.E. | N.D.E. | $x=E$ | $x=E/2$ |
| W22Xd (rib-cooled motors) | 315L | 2P | 6314 | 6314 | 1.4 | 1.5 |
| | | 4P | 6319 | 6316 | 2.9 | 3.1 |
| | | 6P | 6319 | 6316 | 2.6 | 2.8 |
| | | 8P | 6319 | 6316 | 3.4 | 3.7 |
| | 355M/L | 2P | 6316 | 6316 | 2.2 | 2.3 |
| | | 4P | 6322 | 6319 | 4.3 | 4.7 |
| | | 6P | 6322 | 6319 | 3.8 | 4.1 |
| | | 8P | 6322 | 6319 | 3.7 | 4 |

| Permissible Radial Thrust [kN] | | | | | | |
|--------------------------------|--------|-------|----------|--------|-------------------|---------|
| Range | Frame | Poles | Bearings | | Application point | |
| | | | D.E. | N.D.E. | $x=E$ | $x=E/2$ |
| W22Xd (rib-cooled motors) | 315L | 2P | NU314 | 6314 | * | * |
| | | 4P | NU319 | 6316 | 10 | 16.4 |
| | | 6P | NU319 | 6316 | 8.4 | 13.8 |
| | | 8P | NU319 | 6316 | 11.3 | 19.6 |
| | 355M/L | 2P | NU316 | 6316 | * | * |
| | | 4P | NU322 | 6319 | 12.4 | 20.3 |
| | | 6P | NU322 | 6319 | 11.1 | 18.2 |
| | | 8P | NU322 | 6319 | 9.5 | 15.6 |

| Permissible Radial Thrust [kN] | | | | | | |
|--------------------------------|------------|------------|--------------|--------|-------------------|-------|
| Range | Frame | Poles | Bearings | | Application point | |
| | | | D.E. | N.D.E. | x=E | x=E/2 |
| W22Xd (rib-cooled motors) | 355A/B | 2P | NU316 | 6316 | * | * |
| | | 4P | NU322 | 6319 | 4.6 | 7.6 |
| | | 6P | NU322 | 6319 | 3.7 | 6 |
| | | 8P | NU322 | 6319 | 6.9 | 11.3 |
| | 400L/J | 2P | * | * | * | * |
| | | 4P | NU324 | 6324 | 10.5 | 16.4 |
| | | 6P | NU324 | 6324 | 12.7 | 19.7 |
| | | 8P | NU324 | 6324 | 14.1 | 21.9 |
| | 400G | 2P | * | * | * | * |
| | | 4P | NU324 | 6324 | * | * |
| | | | NU324+6324 | NU324 | 16 | 25 |
| | | 6P | NU324 | 6324 | * | * |
| | | | NU324+6324 | NU324 | 17.28 | 27 |
| | | 8P | NU324 | 6324 | * | * |
| | 450K/H | 2P | * | * | * | * |
| | | | NU326 | 6326 | * | * |
| | | 4P | NU326+6326 | NU326 | 19.2 | 30 |
| | | | NU326 | 6326 | * | * |
| | | 6P | NU326+6326 | NU326 | 22.4 | 35 |
| | | | NU326 | 6326 | * | * |
| | 8P | NU326+6326 | NU326 | 24.32 | 38 | |
| | 500K/H | 2P | NU220 + 6020 | NU220 | * | * |
| | | 4P | NU328 | 6328 | * | * |
| | | | NU328+6328 | NU328 | 12.8 | 20 |
| | | 6P | NU328 | 6328 | * | * |
| | | | NU328+6328 | NU328 | 15.36 | 24 |
| | | 8P | NU328 | 6328 | * | * |
| | NU328+6328 | NU328 | 16.64 | 26 | | |
| | 560H/G | 4P | NU328+6328 | NU328 | * | * |
| | | 6P | NU328+6328 | NU328 | * | * |
| 8P | | NU328+6328 | NU328 | * | * | |

(*) On request

Table 3.10 - Permissible radial thrust for roller bearings in rib-cooled motors

Axial Thrusts - Vertical Mounting

The values of permissible axial thrusts applied in the drive end shaft are shown on the table 3.11 for ribbed motors.

The presented maximum axial thrust values consider:

- Normal operation conditions at 50Hz;
- Standard shaft material;
- Non impact applications.

| Permissible Axial Thrust [kN] | | | | | | |
|-------------------------------|--------|--------|----------|------------------|-----------|------|
| Range | Frame | Poles | Bearings | Thrust direction | | |
| | | | | Descendent | Ascendent | |
| W22Xd (rib-cooled motors) | 315L | 2P | 6314 | 0.5 | 6.3 | |
| | | | 7314 | 4.4 | 2.4 | |
| | | 4P | 6319 | 0.5 | 9.4 | |
| | | | 7319 | 9.3 | 1.9 | |
| | | 6P | 6319 | 0.5 | 11.7 | |
| | | | 7319 | 9.7 | 2.3 | |
| | | 8P | 6319 | 0.7 | 12.5 | |
| | | | 7319 | 11.2 | 2.5 | |
| | | 355M/L | 2P | 6316 | 1.2 | 8.1 |
| | | | | 7316 | 4.9 | 4.1 |
| | | | 4P | 6322 | 1.2 | 11.3 |
| | | | | 7322 | 13.8 | 2.4 |
| | 6P | | 6322 | 0.5 | 13.7 | |
| | | | 7322 | 14.4 | 2.6 | |
| | 8P | | 6322 | 1.4 | 13.6 | |
| | | | 7322 | 14.5 | 3.1 | |
| | 355A/B | 2P | 7316 | 4.1 | 3.3 | |
| | | 4P | 7322 | 10.6 | 2.5 | |
| | | 6P | 7322 | 11.8 | 2.6 | |
| | | 8P | 7322 | 13.1 | 4.2 | |
| | 400L/J | 2P | 7318 | 2.2 | 6.0 | |
| | | 4P | 7324 | 9.1 | 5.3 | |
| | | 6P | 7324 | 11.3 | 6.3 | |
| | | 8P | 7324 | 12.1 | 7.4 | |
| | 400G | 2P | 7318 | 1.5 | 10.0 | |
| | | 4P | 7324 | 4.3 | 9.4 | |
| | | 6P | 7324 | 5.4 | 11.8 | |
| | | 8P | 7324 | 4.0 | 14.5 | |
| | 450K/H | 4P | 7326 | 7.0 | 10.6 | |
| | | 6P | 7326 | 6.3 | 14.5 | |
| 8P | | 7326 | 3.0 | 24.8 | | |
| 500K/H | 4P | 7328 | 2.0 | 21.7 | | |
| | 6P | 7328 | 2.0 | 25.6 | | |
| | 8P | 7328 | 2.0 | 26.5 | | |
| 560H/G | 4P | 7328 | * | * | | |
| | 6P | 7328 | * | * | | |
| | 8P | 7328 | * | * | | |

(*) On request

Table 3.11 - Permissible axial thrust in rib-cooled motors

3.2.2.4. Bearing Monitoring

Temperature monitoring of the bearings is extremely important to detect unexpected events in order to take the necessary actions to avoid the reduction of motor bearings lifetime.

Medium and High voltage motors, as standard, are fitted with Pt100 temperature detectors (one per each bearing).

Other types of temperature detectors can be provided, on request.

3.2.3. Sleeve Bearings

Sleeve bearing configuration is available only for W22Xd motors, classified as equipment for gases of Group IIB and I M2 with horizontal mounting form on both drive and non drive end.

The sleeve bearing at the drive end is the guide bearing, which determines the axial position of the shaft. This means that the thrust faces on the drive end bearing shell is not suitable to withstand continuous external axial forces. All axial thrusts must be carried by the driven machine. Shaft thermal expansion will be towards the non drive end, where an axially free bearing is provided.

If there are external radial thrusts, please refer to us.



Figure 3.46 - Sleeve Bearings

- 1 - Shaft seal (IP protection degree)
- 2 - Upper half of the housing
- 3 - Hole for positioning pin
- 4 - Pin for positioning shell
- 5 - Oil filling hole

- 6 - Upper sight glass
- 7 - Eye bolt
- 8 - Screw
- 9 - Upper half of the shell
- 10 - Labyrinth seal
- 11 - Lower half of the shell
- 12 - Spherical seating
- 13 - Loose oil ring
- 14 - Positioning Pin
- 15 - Lower half of the housing
- 16 - Tapped hole for journal bearing temperature measurement
- 17 - Oil level sight glass
- 18 - Tapped hole for oil temperature measurement

In the standard motor design the rotor is not self-aligned and it has a maximum axial play of $\pm 3\text{mm}$ from the mechanical center. The mechanical center is the midpoint between the rotor end floats limits.

The rotor axial center position shall be assured by the driven machine and coupling. This must be taken into consideration during the assembly of the motor together with driven machine (figure 3.44).

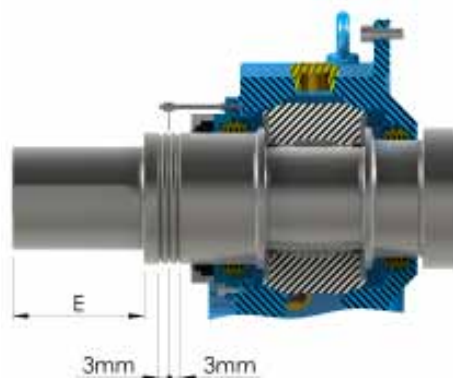

Figure 3.47 - Axial end float

W22Xd motors fitted with sleeve bearings are supplied with:

- DE: Insulated sleeve bearing with grounding
- NDE: Insulated sleeve bearing without grounding

Motors fitted with sleeve bearings can also be equipped with the following optional features:

| Optional features |
|---|
| <ul style="list-style-type: none"> - Vibration probes - Transducers for the measurement of radial relative shaft displacement - Keyphasor - SPM (provision) - Insulated sleeve bearings with grounding for non drive end |

Table 3.12 - Sleeve bearings optional features

Sleeve Bearings Lubrication

Sleeve bearings require less maintenance, longer lubrication intervals and ensure longer lifetime by respecting the recommended lubrication intervals. Mineral oils are used as standard for sleeve bearings of W22Xd motors. The oil viscosity value is defined in ISO 3448 or SSU Standards.

Depending on the thrusts and rotation speed, sleeve bearings with self lubrication (natural cooling) or with oil circulation system (external oil cooling) can be used. Subsequent conversion from self to forced lubrication is used.

Tables 3.13 and 3.14 show the available sleeve bearings for rib-cooled and tube-cooled motors, respectively. This tables also give information about the type and amount of oil to be used and the recommended lubrication intervals.

| Poles | Frame Size | Lubrication Method | Sleeve Bearing | Lubricant | Lubricant Specification | Lubrication interval (hours) | Oil Quantity (liters) | Viscosity Range | |
|--------|------------|--------------------|----------------|--------------|-------------------------|------------------------------|-----------------------|-------------------|---------------|
| | | | | | | | | ISO 40°C | SSU 100°F |
| 2P | 315L | Self-Lubrication | 9-80 | MOBIL DTE 24 | Mineral Oil ISO VG32 | 8000 | 2.8 | 28.8 - 35.2 [cSt] | 137 - 164 [s] |
| | 355M/L | | | | | | | | |
| | 355A/B | | | | | | | | |
| | 400L/J | | | | | | | | |
| | 400G | | | | | | | | |
| | 450K/H | | | | | | | | |
| | 500K/H | | | | | | | | |
| 560H/G | | | | | | | | | |
| 4P+ | 315L | Self-Lubrication | 11-110 | MOBIL DTE 25 | Mineral Oil ISO VG46 | 8000 | 4.2 | 41.4 - 50.6 [cSt] | 193 - 235 [s] |
| | 355M/L | | | | | | | | |
| | 355A/B | | | | | | | | |
| | 400L/J | | | | | | | | |
| | 400G | | | | | | | | |
| | 450K/H | | | | | | | | |
| | 500K/H | | | | | | | | |
| 560H/G | | | | | | | | | |
| | | | 11-125 | | | | | | |

Table 3.13 - Sleeve bearings lubrication data for rib-cooled motors

| Poles | Frame Size | Lubrication Method | Sleeve Bearing | Lubricant | Lubricant Specification | Lubrication interval (hours) | Oil Quantity (liters) | Viscosity Range | |
|-------|------------|--------------------|----------------|--------------|-------------------------|------------------------------|-----------------------|-------------------|---------------|
| | | | | | | | | ISO 40°C | SSU 100°F |
| 2P | 560J/H | Self-Lubrication | 9-90 | MOBIL DTE 24 | Mineral Oil ISO VG32 | 8000 | 2.8 | 28.8 - 35.2 [cSt] | 137 - 164 [s] |
| | 560H/G | | | | | | | | |
| | 630K/J | | | | | | | | |
| | 630J/H | | | | | | | | |
| | 710K/J | Oil Circulation | 11-110 | | | | 4.2 | | |
| 4P+ | 560J/H | Self-Lubrication | 11-125 | MOBIL DTE 25 | Mineral Oil ISO VG46 | 8000 | 4.2 | 41.4 - 50.6 [cSt] | 193 - 235 [s] |
| | 560H/G | | | | | | | | |
| | 630K/J | | | | | | | | |
| | 630J/H | | | | | | | | |
| | 710J/H | | | | | | | | |
| | 710H/G | | | | | | | | |
| | | | 14 - 140 | | | | 8 | | |
| | | | 14-160 | | | | 8 | | |

Table 3.14 - Sleeve bearings lubrication data for tube-cooled motors

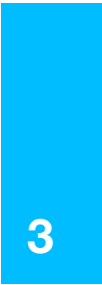

3.3. Degree of Protection

As per IEC 60034-5 Standard, the degree of protection of a rotating electrical machine consists of the letters IP (Ingress Protection), followed by two characteristic numerals, with the following meaning:

- First characteristic numeral: indicates the degree of protection provided by the enclosure to persons and to the parts of the machine inside the enclosure.

5 – Dust protected machine.

Protected against contacts with or approach to live or moving parts inside the enclosure. Ingress of dust is not totally prevented but dust does not enter in sufficient quantity to interfere with satisfactory operation of the machine.

6 – Dust-tight machines.

Ingress of dust totally prevented.

- Second characteristic numeral: indicates the degree of protection provided by the enclosure with respect to harmful effects due to ingress of water.

5 – Machine protected against water jets.

Water projected by a nozzle against the machine from any direction shall have no harmful effect.

6 – Machine protected against heavy seas.

Water from heavy seas or water projected in powerful jets shall not enter the machine in harmful quantities.

W22Xd motors can be supplied to suit different degree of protection, according to the hazardous areas classification and environment conditions.

| Hazardous Areas | IP Protection Degree | |
|---|-----------------------|-------------|
| | Ex d(e) IIB/IIC T4 Gb | Standard |
| Optional | | IP 56/65/66 |
| Ex d(e) IIB/IIC T4 Gb Ex tb IIIC T125°C Db | Standard | IP 65 |
| | Optional | IP66 |
| Ex d(e) I M2 | Standard | IP66 |

Table 3.15 - Protection Degrees

Main and auxiliary terminal boxes are IP66 as standard.

3.4. Cooling System - IC and Noise Level

3.4.1. Rib-Cooled Motors

As standard, W22Xd rib-cooled motors are available with cooling method IC411 (cooled by an external fan) in accordance with IEC 60034-6 Standard. Non ventilated IC410, air over ventilation versions IC418 (TEAO) or forced ventilation IC416 (TEBC) are available on request.



IC411

IC410 / IC418



IC416

Figure 3.48 - Cooling systems examples

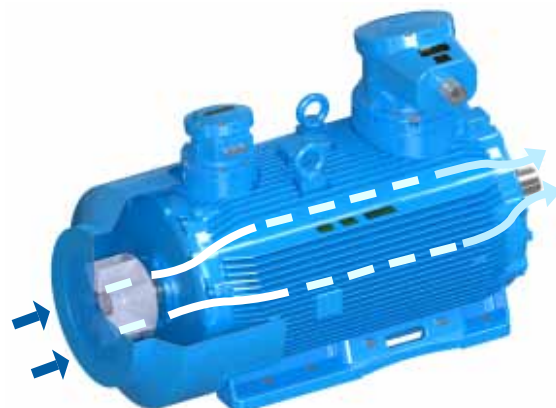

Figure 3.49 - IC411 cooling system principle

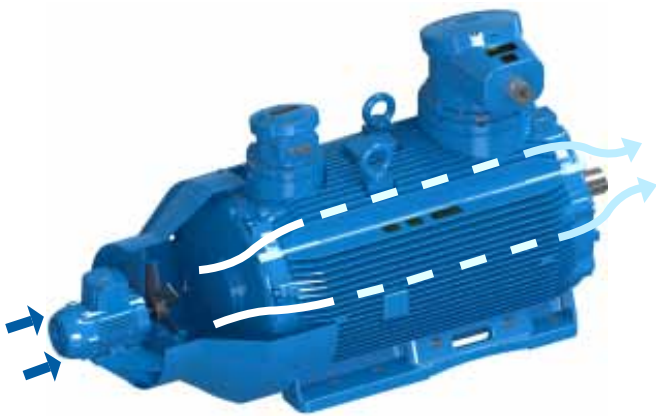

Figure 3.50 - IC416 cooling system principle

The cooling system (fan, non drive end endshield and fan cover) is designed to minimize the noise level and improve thermal efficiency.

Motors sound pressure levels comply with IEC 60034-9 Standard. Tables 3.16 and 3.17 show sound pressure levels in dB(A) @ 1 meter with no load at rated sinusoidal voltage and frequency. The indicated values are subject to ±3 dB(A) tolerance.

| 50Hz | | | | | |
|------------------------------|-------|------------------------------|---------|---------|---------|
| Range | Frame | Sound pressure level - dB(A) | | | |
| | | 2 Poles | 4 Poles | 6 Poles | 8 Poles |
| W22Xd (rib-cooled motors) | 315 | 80 | 76 | 69 | 65 |
| | 355 | 80 | 76 | 69 | 65 |
| | 400 | 80 | 80 | 75 | 74 |
| | 450 | 80 | 80 | 76 | 75 |
| | 500 | 85/82* | 80 | 80 | 80 |
| | 560 | 82* | 86 | 82 | 82 |

(*) Sleeve bearing execution

Table 3.16 - Sound pressure levels for 50Hz ribbed motors, IC411

| 60Hz | | | | | |
|------------------------------|-------|------------------------------|---------|---------|---------|
| Range | Frame | Sound pressure level - dB(A) | | | |
| | | 2 Poles | 4 Poles | 6 Poles | 8 Poles |
| W22Xd (rib-cooled motors) | 315 | 85 | 81 | 74 | 70 |
| | 355 | 85 | 81 | 74 | 70 |
| | 400 | 85 | 85 | 80 | 79 |
| | 450 | 85 | 85 | 81 | 80 |
| | 500 | 86* | 85 | 85 | 85 |
| | 560 | 86* | 91 | 87 | 87 |

(*) Sleeve bearing execution

Table 3.17 - Sound pressure levels for 60Hz ribbed motors, IC411

For load conditions, the IEC 60034-9 Standard indicates the incremental expected increase of power noise level over no load condition.

The incrementals in sound pressure with sinusoidal rated voltage and frequency supply are indicated in the table 3.18.

| Incrementals of sound pressure - dB(A) | | | | |
|--|---------|---------|---------|---------|
| Frame (mm) | 2 poles | 4 poles | 6 poles | 8 poles |
| H = 315 | 2 | 3 | 5 | 6 |
| H ≥ 355 | 2 | 2 | 4 | 5 |

Table 3.18 - Maximum expected increase of sound pressure level at load condition

Note:

The global noise level can be reduced up to 2dB(A) with the installation of a drip cover.

3.4.2. Tube-Cooled Motors

W22Xd tube-cooled motors are available, as standard, with cooling method IC511 (cooled through an integrated heat exchanger) in accordance with IEC 60034-6 Standard. Forced ventilation (IC516) is available on request.



IC511



IC516

Figure 3.51 - Cooling systems examples

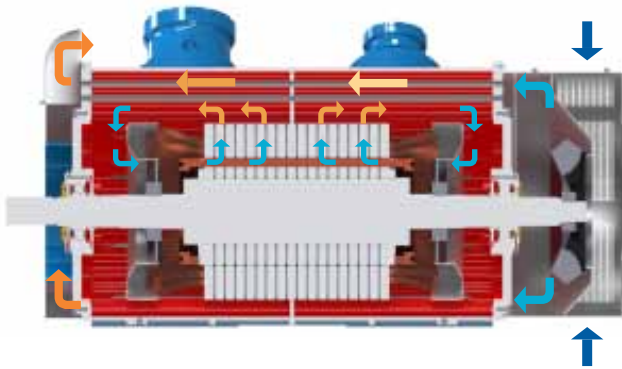

Figure 3.52 - IC511 cooling system principle

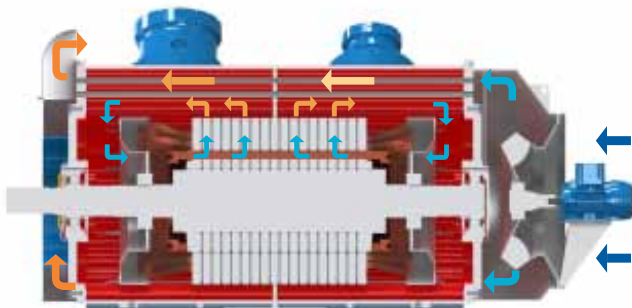

Figure 3.53 - IC516 cooling system principle

The cooling system (fan, non drive end endshield and fan cover) is designed to minimize the noise level and improve thermal efficiency.

Motors sound pressure levels comply with IEC 60034-9 Standard. Tables 3.19 and 3.20 show sound pressure levels in dB(A) @ 1 meter with no load at rated sinusoidal voltage and frequency. The indicated values are subject to ± 3 dB(A) tolerance.

| | | 50Hz | | | |
|----------------------------------|-------|------------------------------|---------|---------|---------|
| Range | Frame | Sound pressure level - dB(A) | | | |
| | | 2 Poles | 4 Poles | 6 Poles | 8 Poles |
| W22Xd (tube-cooled motors) | 560 | 85 | 84 | 82 | 82 |
| | 630 | 85 | 85 | 83 | 82 |
| | 710 | 87 | 86 | 85 | 84 |

Table 3.19 - Sound pressure levels for 50Hz tube-cooled motors

| | | 60Hz | | | |
|----------------------------------|-------|------------------------------|---------|---------|---------|
| Range | Frame | Sound pressure level - dB(A) | | | |
| | | 2 Poles ^(*) | 4 Poles | 6 Poles | 8 Poles |
| W22Xd (tube-cooled motors) | 560 | 89 | 88 | 86 | 86 |
| | 630 | 89 | 89 | 87 | 86 |
| | 710 | 91 | 90 | 89 | 88 |

(*) Sleeve bearing execution

Table 3.20 - Sound pressure levels for 60Hz tube-cooled motors

Taking IEC 60034-9 Standard as base, the incremental expected increase of sound pressure level from no load to load condition with sinusoidal supply at nominal speed are indicated in the table 3.18.

3.5. Vibration Level

Vibration of an electrical machine is closely related to its assembly on the application and, thus, it is generally desirable to perform vibration measurements under installation and operational conditions. Nevertheless, to allow evaluation of the vibration generated by the electrical machine itself in a way to allow reproducibility of the tests and the obtaining of comparative measurements, it is necessary to perform such measurements with the machine uncoupled, under controlled test conditions. The test conditions and vibration limits described here are those found in IEC 60034-14 Standard.

The severity of vibration is the maximum value of vibration found among all the recommended measurement points and directions. The table below indicates the recommended admissible values of vibration severity under IEC 60034-14 Standard for the frames IEC higher than 280, for degrees of vibration A and B.

All rotors are dynamically balanced with half key. The motor vibration levels, as standard, meets Grade A as per IEC 60034-14 Standard. As an option, motors can be supplied in conformance with vibration level of Grade B. The maximum RMS (Root Mean Square) speed and vibration levels in mm/s for Grades A and B are shown in table 3.21.

| Vibration | Frame | H > 280 |
|-----------|-----------------|----------------------------|
| | Condition | Vibration speed RMS (mm/s) |
| Grade A | Free suspension | 2.8 |
| | Rigid Mounting | 2.3 |
| Grade B | Free suspension | 1.8 |
| | Rigid Mounting | 1.5 |

Table 3.21 - Vibration levels

3.6. Impact Resistance

The W22Xd motor line withstands mechanical impacts of 20J, in accordance with IEC/EN 60079-0 Standard, ensuring superior mechanical strength for the most demanding applications namely for group I (mining). This impact resistance test does not have a direct correlation with the IEC/EN 62262 Standard - "Degrees of protection provided by enclosures for electrical equipment against external mechanical impacts (IK code)". However 20J is the equivalent to IK10.

3.7. Painting

W22Xd motors, as standard, are painted according to 202P painting plan (WEG code). This plan consists of:

- Primer: one layer with 20 to 30 µm of alkyd primer;
- Intermediary: one layer with 80 to 95 µm of isocyanate epoxy coating;
- Finishing: one layer with 65 to 75 µm of polyurethane coating.

This painting plan withstands a minimum of 500 hours salt spray test according to ISO 9227:2012 and can be exposed to sheltered or non-sheltered industrial aggressive environments.

Complete information about painting plans and comparison with DIN EN ISO 12944 Standard is shown in table 3.22.

Painting plans description and recommended use:

| DIN EN ISO 12944 "Paints and Varnishes - Corrosion protection of steel structures by protective paint systems | | | | | WEG Painting Plans | | | | Surface Preparation (Blast-cleaning) |
|---|------------|------------|----------------------|-------------------------------|--------------------|--------------------------------|----------------------|-------------------------------|--------------------------------------|
| Classification | Range | Durability | Total Thickness (µm) | Salt Spray Resistance (hours) | Reference | Top Coat | Total Thickness (µm) | Salt Spray Resistance (hours) | |
| C3 | > 15 years | High (H) | 80 - 150 | 480 | 202P | Aliphatic Acrylic Polyurethane | 165 - 200 | 500 | Sa 2 ½ |
| C5 (I and M) | > 15 years | High (H) | 280 - 320 | 1440 | 212P | Aliphatic Acrylic Polyurethane | 240 - 340 | 10000 | |
| C5 (I and M) | > 15 years | High (H) | 280 - 320 | 1440 | 212E | Epoxy Polyamide | 270 - 380 | 10000 | |
| C5 (I and M) | > 15 years | High (H) | 280 - 320 | 1440 | 213E | Epoxy Polyamide | 350 - 480 | 10000 | |
| C5 (I and M) | > 15 years | High (H) | 280 - 320 | 1440 | 214P | Aliphatic Acrylic Polyurethane | 140 - 200 | 3000 | |
| C5 (I and M) | > 15 years | High (H) | 280 - 320 | 1440 | 216P | Epoxy Polyurethane | 420 - 590 | 12000 | |

Table 3.22 - Painting Plans

Note:

According to IEC 60079-0 Standard for Zone 1 Gas Group IIC, the total thickness shall be less than 200µm. If the painting plan exceeds 200µm, an additional nameplate informing the risk of electrostatic discharge will be added to the motor.

3.8. Mounting Arrangements - IM

W22Xd rib-cooled motors are supplied, as standard, in the B3T configuration, with the terminal box on top with cable entry to the left hand side when viewed from shaft end.

W22Xd tube-cooled motors are supplied, as standard, in the B3L configuration, with the terminal box on the left hand side when viewed from shaft end.

3



Figure 3.54 - B3T standard rib-cooled motors mounting



Figure 3.55 - B3L standard tube-cooled motors mounting

The mounting arrangements for the W22Xd line comply with IEC 60034-7 Standard.

Standard mounting arrangements and their variations for frame sizes up to and included 400 are shown in table 3.23.

| Mounting Arrangements | | |
|-----------------------|---------|---------|
| IM B35 | IM V15 | IM V36 |
| IM 2001 | IM 2011 | IM 2031 |
| | | |
| IM B5 | IM V1 | IM V3 |
| IM 3001 | IM 3011 | IM 3031 |
| | | |

Table 3.23 - Mounting arrangements

Standard mounting arrangements and their variations for frame sizes 450 and above are shown in table 3.24.

| Mounting Arrangements | |
|-----------------------|---------|
| IM B3 | IM V15 |
| IM 1001 | IM 2011 |
| | |
| IM B35 | IM V1 |
| IM 2001 | IM 3011 |
| | |

Table 3.24 - Mounting arrangements

| Mounting Arrangements | | |
|-----------------------|---------|---------|
| IM B3 | IM V5 | IM V6 |
| IM 1001 | IM 1011 | IM 1031 |
| | | |

After the mounting arrangement code, a characteristic letter is used to define the terminal box position. For example, the mounting code IM B3 can be seen in WEG documents as detailed below (without IM code):

- B3L – terminal box on left hand side viewed from drive end side
- B3T – terminal box on top of the motor frame
- B3R – terminal box on right hand side viewed from drive end side



Figure 3.56 - B3R and B3L optional mountings in rib-cooled motors



Figure 3.59 - Example of a rib-cooled motor IM2202



Figure 3.57 - B3R and B3T optional mountings in tube-cooled motors

For motors mounted vertically shaft down the drip cover is standard, and optional for other mounting arrangements.



Figure 3.58 - Example of a rib-cooled motor with drip cover

Special mounting arrangements are available under request, for example, IM2202, motor with feet and flange in both ends (figure 3.56).

3.9. Nameplates and Additional Plates

For W22Xd motors the main nameplate supplies information determining motor construction and performance characteristics. All nameplates used on W22Xd motors are made of stainless steel.

| | | | | | | | | | | | | | | | | | | | | | | | |
|-------------------|---|-----------------|---|-----------------|---|-----------------|---|-----------------|----|-----------------|----|--|----|-------------------|----|----------|----|----|----|-----------------------|----|----|--|
| WEG W22Xd | | | | | | | | | | CE | | VDE 0530 IEC 60034 | | | | | | | | | | | |
| 2 | 3 | 4 | 5 | 6 | 7 | 8 | 9 | 10 | 11 | 12 | 13 | 14 | 15 | 16 | 17 | 18 | 19 | 20 | 21 | 22 | 23 | 24 | |
| -3 W22XdB 450KH 4 | | | | | | | | | | IP 55 | | INS. CL. F | | Δt 80 K | | S.F. 1.0 | | S1 | | AMB. -20°C up to 40°C | | | |
| V | | Hz | | kW | | RPM | | A | | P.F. | | IE CODE | | 100% | | | | | | | | | |
| Y6000 | | 50 | | 1500 | | 1493 | | 171 | | 0.87 | | | | 97.2 | | | | | | | | | |
| I ₁₀ | | I ₁₁ | | I ₁₂ | | I ₁₃ | | I ₁₄ | | I ₁₅ | | | | I ₁₆ | | | | | | | | | |
| 6328 C3 | | 6328 C3 | | POLYREX EM-ESSO | | 93 | | 4200 | | 22 | | Y L ₂ L ₁ L ₃ | | Alt 1000 m.a.s.l. | | 11700 kg | | 24 | | | | | |
| 19 | | 20 | | 21 | | | | | | | | | | | | | | | | | | | |

Figure 3.60 - Main nameplate for W22Xd motors (frame sizes up to 450 and included)

- 1 - Conformity labels
- 2 - Three phase
- 3 - Frame size
- 4 - Degree of protection
- 5 - Insulation class
- 6 - Temperature rise
- 7 - Service factor
- 8 - Service duty
- 9 - Ambient temperature
- 10 - Rated operating voltage
- 11 - Frequency
- 12 - Motor rated power
- 13 - Full load speed (rpm)
- 14 - Rated operating current
- 15 - Power factor
- 16 - Efficiency
- 17 - Drive end bearing specification
- 18 - Non drive end bearing specification
- 19 - Amount of grease / oil
- 20 - Lubrication intervals in hours
- 21 - Type of grease / oil for bearings
- 22 - Connection diagram
- 23 - Altitude
- 24 - Motor weight

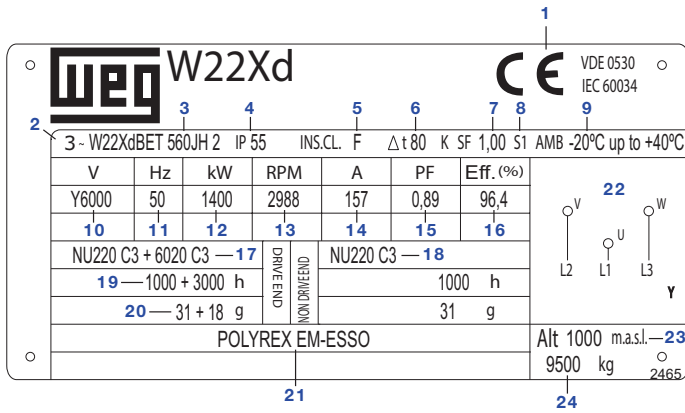

Figure 3.61 - Main nameplate for W22Xd motors (frame sizes 500 and above)

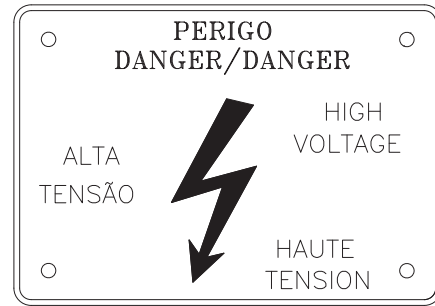

Figure 3.62 - Main terminal box plates

- Direction of rotation nameplate - located on fan cover

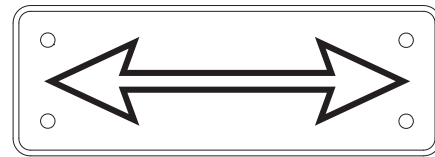

Figure 3.63 - Direction of rotation plate (Bidirectional)

- Plate of cable entry holes

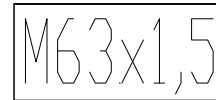

Figure 3.64 - Cable entry holes size marking

- Auxiliary connection diagram plate

Connection diagram plate for Medium/High voltage motors is shown in figure 3.62.

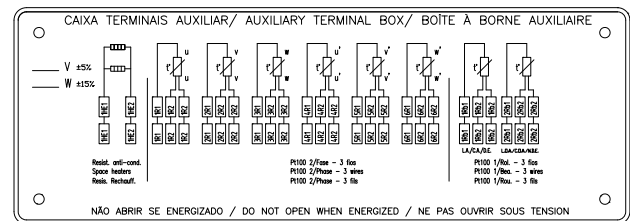
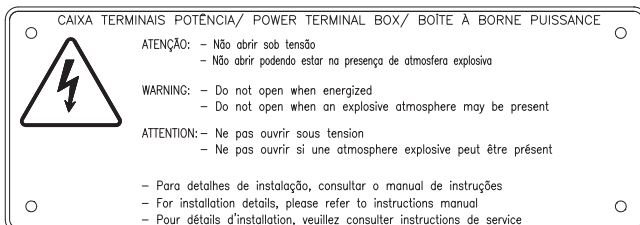

Figure 3.65 - MV / HV auxiliar connection diagram plate

Besides the main nameplate, motors are equipped, as standard, with other plates as follows:

- Main terminal box plates



Some optional features require special plates such as:

- Neutral terminal box indicative plate
- 2nd auxiliary terminal box indicative plate
- VSD plate
- AOM plate

Other optional plates can be included when required.

1 - Conformity labels

2 - Three phase

3 - Frame size

4 - Degree of protection

5 - Insulation class

6 - Temperature rise

7 - Service factor

8 - Service duty

9 - Ambient temperature

10 - Rated operating voltage

11 - Frequency

12 - Motor rated power

13 - Full load speed (rpm)

14 - Rated operating current

15 - Power factor

16 - Efficiency

17 - Drive end bearing specification

18 - Non drive end bearing specification

19 - Amount of grease / oil

20 - Lubrication intervals in hours

21 - Type of grease for bearings / Type of oil for sleeve bearings

22 - Connection diagram

23 - Altitude

24 - Motor weight

3.10. Assembly Systems for Foot Mounted Motors

3.10.1. Leveling Shims

The correct motor leveling and the alignment with the driven machine are two of the most important variables that extend the useful service life of the motor. As so, W22Xd rib-cooled and tube-cooled motors can be supplied, as an optional feature, with additional 4 kits of leveling shims (one kit per foot), see figure 3.63.



Figure 3.66 - Leveling shims

| Leveling shims kit | |
|--------------------|-----------|
| Quantity | Thickness |
| 2 | 2 mm |
| 1 | 1 mm |
| 2 | 0,4 mm |
| 3 | 0,1 mm |

Table 3.25 - Leveling shims kit per foot

3.10.2. Anchor Bolts

In order to achieve a correct fastening of W22Xd rib-cooled and tube-cooled motors, anchor bolts can be provided, as an optional feature, see figure 3.64. WEG anchor bolts are correctly designed to comply with all applied static and dynamic loads, including the most severe conditions like the occurrence of locked rotor.



Figure 3.67 - WEG Anchor bolt

3.11. Seismic Hazards

Some of the sites of oil & gas extraction in the world are placed in zones with occurrence of seismic hazards. In order to eliminate the risks of essential equipment failure in seismic zones, W22Xd rib-cooled and tube-cooled motors can be designed to support the worst seismic conditions according to the main worldwide Standards, for example EN 1998-1 Eurocode 8 for Europe, UBC 1997 from USA, AS 1170.4-2007 from Australia / New Zealand and NCh 2369 from Chile.

The assembly and major motor components as frame, rotor, endshields and bearing housings are individually dimensioned to prevent any harm due to a seismic hazard, keeping the working capability and the safety of the surrounding area.

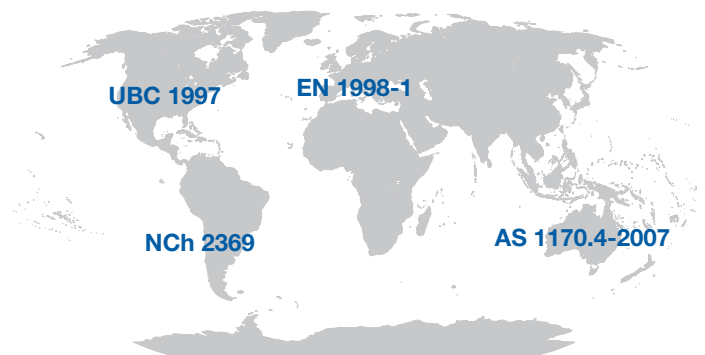

Figure 3.68 - Main Standards for seismic conditions

3.12. Mechanical Protection Equipment

3.12.1. Proximitors Transducer and Keyphasor

W22Xd rib-cooled and tube-cooled motors can be equipped, as optional, with proximitors sensors. These sensors measure the radial displacement of the shaft (shaft unbalance) in sleeve bearings arrangement. Additionally a Keyphasor sensor can be supplied to inform the phase reference.

Proximitors sensors are installed in pairs, 90° apart from each other, in the sleeve bearing, and are directed to a specially machined area of the shaft. These sensors provide an output voltage directly proportional to the distance between the probe tip and the observed conductive surface.

Keyphasor sensor is the third probe, applied in the sleeve bearing, and it is a current transducer that is pointed to the groove on the shaft, with an output of one pulse per revolution, allowing the measurement of the phase angle and rotation speed.

The proximitors and keyphasors sensors are protected against electronic interference (RFI/EMI), complying with the European

Standards and ensuring higher reliability in measurement and providing a better protection of the rotating machinery.

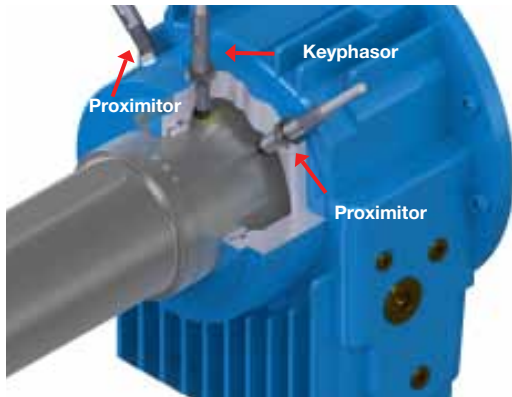

Figure 3.69 - Sleeve bearing with proximitor transducers and keyphasor

3

3.12.1. Accelerometer and Velomitor

W22Xd rib-cooled and tube-cooled motors can be equipped, as optional, with accelerometers or velomiters. These sensors are installed in the endshields with the possibility of installing one, two or three sensors on orthogonal axis.

The accelerometers are made of piezo-electric crystals. These materials have the particularity to generate an electric charge if one force is applied. When the motor suffers vibrations, the force is proportional to the acceleration of the mass and the applied forces on the piezo-electric crystals produce the output signal. This signal is also proportional to the output reading acceleration. The velomitor consists of an accelerometer with a built-in electronic integrator, where the value of velocity results from the numerical integration of the acceleration.

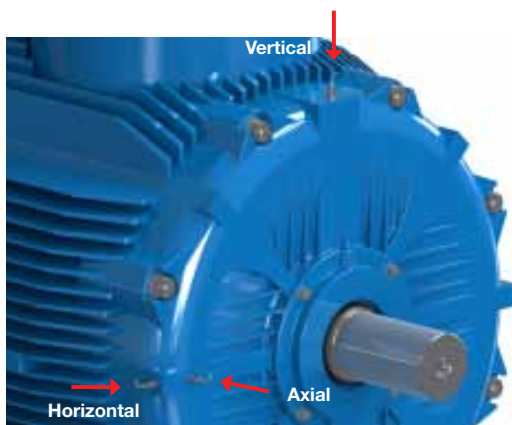

Figure 3.70 - Motor equipped with accelerometers



Electrical Features

| | |
|--|-----------|
| 4.1. Voltage and Frequency | 61 |
| 4.2. Ambient / Insulation | 61 |
| 4.3. Motor Protection | 63 |
| 4.4. Variable Speed Drive | 67 |
| 4.5. Duty Cycles | 71 |
| 4.6. Efficiency Levels | 75 |
| 4.7. Main Electrical Connections | 75 |
| 4.8. Tolerances for Electrical Data | 75 |

Electrical Features

4.1. Voltage and Frequency

4.1.1. Tolerances

In IEC/EN 60034-1 Standard the combination of voltage and frequency variations are classified as zone A or zone B, as per figure 4.01.

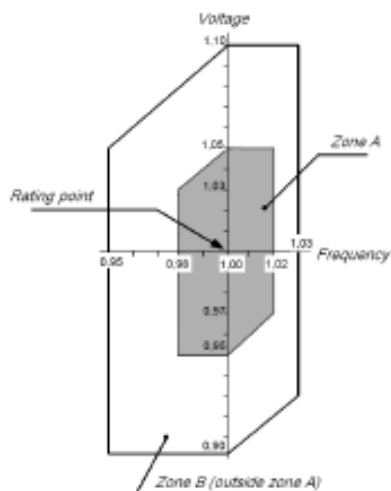

Figure 4.01 - Rated voltage and frequency limits for electrical motors

IEC/EN 60034-1 Standard states that the motor must be suitable to perform its main function (supply torque) continuously at Zone A. However, this motor may not fully meet its performance characteristics due to power supply voltage and frequency variation, which can result in temperature rise above the rated value.

The motor must also be suitable to perform its main function (supply torque) at Zone B. However, the performance characteristic changes will be greater than those operating at Zone A. The temperature rise will also be higher than that of rated voltage and frequency and that operating at Zone A. Prolonged operation near Zone B boundary is not recommended. WEG flameproof motors are tested in accordance with IEC/EN 60079-0 Standard that imposes a voltage supply of -10% for validation of enclosure surface temperature.

For motors with increased safety terminal box, voltage and tolerances are limited by IEC/EN 60079-7 Standard. The maximum allowed voltage for Ex e equipment is 10kV ± 10%. Standard WEG motors with increased safety terminal boxes for voltages between 6300V and 6600V, are limited to a positive tolerance of ± 5%. For other options please refer to us.

4.1.2. Voltage Levels

Standard voltages for W22Xd MV and HV motors are indicated in table 4.01:

| Voltage Range | | |
|---------------|------|-------------------|
| MV | 50Hz | Y 3.0kV / Y 6.0kV |
| | 60Hz | Y 4.16kV |
| HV | 50Hz | Y 10.0kV |

Table 4.01 - W22Xd standard MV and HV voltages

As an option WEG can supply motors with voltages within the range 1.100V < V ≤ 11.000V.

As standard, W22Xd motors are supplied for operation in Zone A.

4.2. Ambient / Insulation

Ambient Temperature and Altitude

Unless otherwise specified, the rated power outputs shown in the electrical data tables within this catalogue refer to continuous duty operation S1, as per IEC/EN 60034-1 Standard and under the following conditions:

- With ambient temperature range -20°C to +40°C;
- With altitudes up to 1000 meters above sea level.

For operating temperatures and altitudes differing from those above, the factors indicated in table 4.02 (correction factors for altitude and ambient temperature) must be applied to the nominal motor power rating in order to determine the derated available output (Pmax).

$$P_{max} = P_{nom} \times \text{correction factor}$$

| T [°C] | Altitude [m] | | | | | | | | |
|--------|--------------|------|------|------|------|------|------|------|------|
| | 1000 | 1500 | 2000 | 2500 | 3000 | 3500 | 4000 | 4500 | 5000 |
| 10 | | | | | | | 0,97 | 0,92 | 0,88 |
| 15 | | | | | | 0,98 | 0,94 | 0,90 | 0,86 |
| 20 | | | | 1 | 0,95 | 0,91 | 0,87 | 0,83 | |
| 25 | | | 1 | 0,95 | 0,93 | 0,89 | 0,85 | 0,81 | |
| 30 | | | 1 | 0,96 | 0,92 | 0,90 | 0,86 | 0,82 | 0,78 |
| 35 | | 1 | 0,95 | 0,93 | 0,90 | 0,88 | 0,84 | 0,80 | 0,75 |
| 40 | 1 | 0,97 | 0,94 | 0,90 | 0,86 | 0,82 | 0,80 | 0,76 | 0,71 |
| 45 | 0,95 | 0,92 | 0,90 | 0,88 | 0,85 | 0,81 | 0,78 | 0,74 | 0,69 |
| 50 | 0,92 | 0,90 | 0,87 | 0,85 | 0,82 | 0,80 | 0,77 | 0,72 | 0,67 |
| 55 | 0,88 | 0,85 | 0,83 | 0,81 | 0,78 | 0,76 | 0,73 | 0,70 | 0,65 |
| 60 | 0,83 | 0,82 | 0,80 | 0,77 | 0,75 | 0,73 | 0,70 | 0,67 | 0,62 |

Table 4.02 - Correction factors for altitude and ambient temperature

Unless otherwise specified, all motors are supplied with Class F insulation and Class B (80K) temperature rise at normal operating conditions.

The difference between the temperature rise of the class F insulation (105K) and the temperature rise of the class B design (80K) means that, in practice, motors are suitable to supply output ratings above the rated values up to a limit where the temperature rise reaches the temperature rise value of the insulation class.

The ratio between temperature rise and service factor is given by the equation below:

$$\Delta T_{FINAL} \approx (S.F.)^2 \times \Delta T_{INITIAL}$$

Upon service factor calculation, we can see that Service Factor is approximately 1.15. This reserve of temperature also allows in theory that most of the motors with class B temperature rise (80K) can operate continuously at:

- Up to 15% above its rated output power, considering 40°C ambient temperature and 1.000 m.a.s.l.;
- Up to 55°C ambient temperature, keeping the rated output power;
- Up to 3000 m.a.s.l., keeping the rated output power.

4

Note:

Please note that under these combined conditions between ambient and temperature rise motors will reach Class F limits. Bearing lubrication intervals will change under operating conditions other than 40°C maximum ambient temperature and 1000 meters above sea level.

Nevertheless, when operating conditions are different from the indicated on the nameplate, all flameproof motors must be validated by WEG technical support.

Insulation System

For medium and high voltage motors the insulation system is class F type and consists mainly in:

- Rectangular bare copper wire with mica tapes (used in respect of the applied voltage);
- Coil main insulation with mica tapes;
- Straight part of coil with conductive tape;
- Semi-conductive tape;
- Coil heads mechanical protection with polyester shrinking tape;
- VPI system with polyestermide resin of class H type.

Medium voltage motors for use with variable speed drives have special insulation system.

Class H insulation system is available on request.

4.2.1. Humidity protection - Space Heaters and Tropical Treatment

The integrity of the insulation system is the primary consideration when determining the lifetime of an electric motor. High humidity can result in premature deterioration of the insulation system. WEG recommends the use of space heaters on motors installed in environments with high relative air humidity, in which the motor may remain idle for periods longer than 24 hours.

In extreme cases, motors installed in environments with relative air humidity higher than 95%, regardless of the operating schedule is also strongly recommended the use of space heaters and an alkyd resin based varnish painting known as tropical treatment, applied in the internal components of the motor.

W22Xd flameproof motors receive a tropicalized painting as standard.

W22Xd medium and high voltage standard motors are also equipped with tubular space heaters of 230V (±5%). Other space heaters voltages can be supplied on request.

The power ratings and number of space heaters fitted are indicated in table below:

| Rib-cooled motors | Quantities | Power rated per Heater [W] |
|-------------------|------------|----------------------------|
| 315 | 2 | 70 |
| 355 | 2 | 87 |
| 400 | 2 | 150 |
| 450 | 2 | 200 |
| 500 | 2 | 250 |
| 560 | 2 | 300 |

| Tube-cooled motors | Quantities | Power rated per Heater [W] |
|--------------------|------------|----------------------------|
| 560 | 2 | 400 |
| 630 | 2 | 450 |
| 710 | 2 | 500 |

Table 4.03 - Quantity and power of W22Xd space heaters

More information can be obtained in Section 5 - Standard and Optional Features (Scope).

4.3. Motor Protection

The temperature inside the enclosure of an electric machine increases during operation.

The temperature rise is defined at the design stage and, normally is kept within the limits of class B temperature rise, which means 80K. The ambient temperature considered in the design is 40°C, according to IEC/EN 60034-1 Standard, and the insulation system is normally rated class F (155°C) – see table below.

| | | |
|-------------------------|------|----------------------------|
| Thermal Gap | 25 K | 155°C material class limit |
| Hottest - Coldest point | 10 K | |
| Temperature rise | 80 K | |
| Ambient temperature | 40°C | |

Table 4.04 - Class F insulation

Overheating must be avoided to ensure a longer motor lifetime and a safer operation.

As standard, W22Xd medium/high voltage motors are equipped with:

Windings protection

- Two Pt100 per phase (3 wires), connected in the auxiliary terminal box.

Bearings protection

- One Pt100 per bearing (3 wires), connected in the auxiliary terminal box.

WEG recommends the connection and control of all installed thermal probes. The maximum setting temperatures in W22Xd MV and HV standard motors, shall be as follows:

| | Alarm | Trip |
|------------------------------|-------|-------|
| Winding - rib cooled motors | 140°C | 155°C |
| Winding - tube cooled motors | 130°C | 140°C |
| Bearings | 110°C | 120°C |
| Sleeve Bearings | 100°C | 110°C |

Table 4.05 - Alarm and trip values for winding and bearings

Nevertheless temperature settings shall be adjusted for lower values, whenever possible according to the power supply, load and ambient temperature conditions.

Other protections can be implemented on request. For more information please refer to Section 5 - Standard and Optional Features (Scope).

4.3.1. Power Protection Equipment

W22Xd motors terminal boxes can be equipped with different power protection solutions such as:

- Current Transformers (for measurement or differential protection);
- Surge Arresters;
- Surge Capacitors;
- Partial Discharge measurement system.

These equipments can be fitted individually or in a complete pack.

On request, W22Xd terminal boxes can also be supplied with fault rate level certification.

The basic working principles of these equipments are explained in the next paragraphs.

4.3.1.1. Current Transformers

A Current Transformer (CT) is a device that can measure alternating current in a conductor. The CT measures the alternating magnetic field that surrounds the conductor. As the alternating current carried by the conductor is proportional to this magnetic field, the CT produces an output current at a magnitude level proportional to the current in the conductor. This output current is used for measuring or protective purposes.

Usually CT's only have the secondary winding around the circular core and the primary winding consists of the current conductor passing once through an opening in the CT. This is called a "Ring Type" CT (or "Donut Type"). CT's with two or more turns wound on the core together with the secondary winding are called "Wound Primary Type".

A Current Transformer is specified by the ratio between the primary and secondary currents. This ratio indicates not only the relation between the primary and secondary currents but also the current rating of the CT.

For example, a ratio of 100:5 means that a current of 100A flowing in the primary will result in a current of 5A in the secondary. Primary current higher than 100A might damage the secondary winding.

CT's can have the same ratio (20:1 and 100:5), although they will not be equivalent as their rated currents are different. Common rated secondary currents are 5A and 1A.

An important characteristic of a CT is the Burden rating, that is the secondary power that a CT can supply and it is expressed in VA. This means that a CT needs a load connected to the secondary circuit to maintain the current in the correct magnitude. It should be noticed that the total Burden imposed on the secondary circuit is the sum of all loads connected to it

considering also the Burden imposed by the connection cable and the resistance of the connectors. All loads/devices must be always connected in series with the secondary winding. For example, if a connection cable and connectors have a resistance of $0,5\Omega$ and the secondary current rating is 1A, the Burden of the cable, calculated by $(R \times I^2)$, is $0,5 \times 1^2 = 0,5VA$ and must be added to the Burden of the measuring/protection devices.

If the Burden imposed on the CT secondary winding by the connected devices and cables exceeds the rated Burden of the CT it will saturate and the secondary current will lose the proportional relation with the primary current.

Common Burden ratings are 2.5; 5; 10; 15 and 30VA.

Accuracy class is the third important parameter that specifies a CT. This parameter defines the deviation between the secondary current measured magnitude and the real value according to the CT ratio.

IEC 60044-1 Standard defines the accuracy classes for measurement CT's as 0.1, 0.2s, 0.2, 0.5, 0.5s, 1, and 3. For example, the ratio (primary to secondary current) error of a Class 1 CT is 1% at rated current; the ratio error of a Class 0.5 CT is 0.5% or less.

Errors in phase angle displacement between primary and secondary currents are also important especially with measuring instruments. Each class has also an allowable maximum phase error for a specified load impedance.

Current transformers used for protection also have accuracy requirements with overload currents to guarantee the accurate performance of relays during system faults. A CT with a marking of 5P10 is able to operate at 10 times the rated secondary current (at rated Burden) with accuracy within 5%. The letter "P" means that the CT is for protection purpose.

W22Xd motors can be equipped with Ring Type CTs on request. For measuring purposes the CT measures the current that flows in each supply phase cable that is passed through the window. When requested, and if nothing is indicated by the customer, W22Xd motors are equipped with measuring CTs with the following characteristics:

- Ratio: 170/1
- Burden: 5VA
- Class: 1

For differential protection each supply phase cable (phase winding input current) is passed through the CT and each phase winding output current cable is passed through the same phase CT window in the opposite direction. In this case the CT will measure the difference between the two currents and if the value of the currents is not the same an output will be generated in the secondary current. When requested, and if nothing is indicated by the customer, W22Xd motors are equipped with differential protection CTs with the following characteristics:

- Ratio: 50/5
- Burden: 5VA
- Class: 5P10

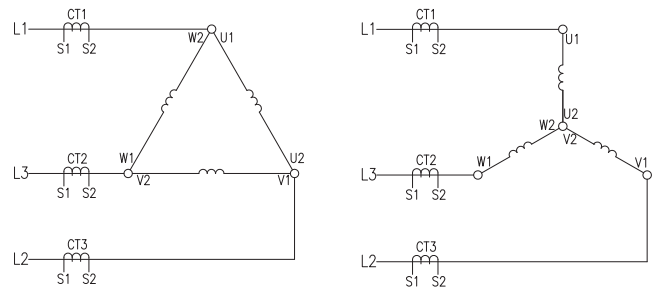

Figure 4.02 - Measuring CT's Connections

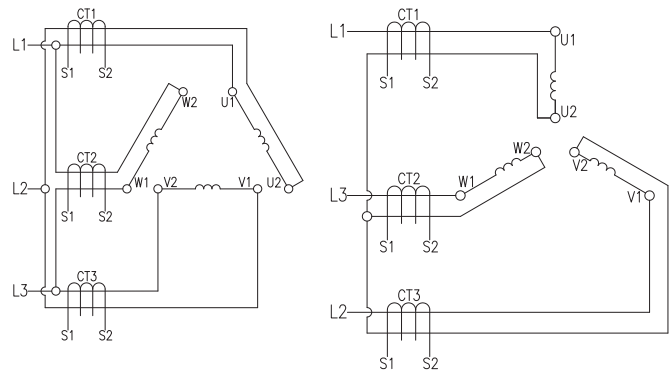

Figure 4.03 - Differential Protection CT's Connections



Figure 4.04 - Ring type Current Transformers

4.3.1.2. Surge Arresters and Surge Capacitors

Surge Arresters

A Surge Arrester is a device that electrically protects equipment from lightning and switching surges. When a surge arrester is connected in parallel with the motor winding it will clamp the voltage produced by the lightning and divert the lightning to the ground, avoiding a winding damage. Surge Arresters are internally made by metal oxide blocks that at rated voltages are insulators and will not conduct current. At higher voltages, caused by lightning, these blocks become conductors. In summary, Surge Arresters act as a fast switch that is open when rated voltage is

applied and as a closed switch when a lightning voltage occurs (the Surge Arrester can turn on and off in microseconds).

Surge Arresters selection for motors application consists mainly in matching the electrical characteristics of the arresters with the motor electrical construction. When selecting a Surge Arrester it is necessary to define at least the following parameters:

- Maximum Continuous Operating Voltage (MCOV-IEEE or Uc-IEC designations): It is the maximum designated Root Mean Square (RMS) value of power frequency voltage that may be applied continuously between the terminals of a Surge Arrester;
- Ur-Rated Voltage value of an Arrester: Defines the maximum permissible RMS value of power-frequency voltage between the Surge Arrester terminals to which it is designed to operate correctly under temporary overvoltage conditions (TOV) as established in the operating duty tests (IEC);
- Temporary overvoltages (TOV): Oscillatory power frequency overvoltages of relatively long duration (from a few cycles to hours);
- Line discharge class and Energy Capability: WEG adopts 10kA, Class 1 Surge Arresters.

As an example, a Surge Arrester to be used in a motor with a nominal voltage of 6kV is selected as follows:

- Motor nominal voltage (between phases): 6kV;
- Maximum continuous operating voltage (Uc): $6/\sqrt{3} \times 1,1$ (10%) = 3,81kV;
- Selection of Ur characteristic from Surge Arrester Supplier catalogue (select the Ur that is indicated for the next higher Uc value from the Surge Arrester supplier catalogue in relation with the calculated value of 3,81kV): 6,0kV (this value can be different between suppliers);
- Definition of Line discharge: 10kA, Class 1 (WEG option). Class 2 can be considered on request.

On request, W22Xd motors can be supplied with Surge Arresters connected between the main terminal box phase terminals and the ground. To guarantee a low impedance path to earth through the Surge Arrester, copper cables with 120mm² section are used. If nothing required otherwise, the following selection of Surge Arresters are applied:

| Motor nominal voltage (kV) | Ur - Rated voltage (kV) | Uc - Max. continuous voltage (kV) | Nominal discharge current (kA) | Line discharge class |
|----------------------------|-------------------------|-----------------------------------|--------------------------------|----------------------|
| $U \leq 3,3$ | 3,0 | 2,55 | 10 | 1 |
| $3,3 < U \leq 6,6$ | 6,0 | 5,10 | 10 | 1 |
| $6,6 < U \leq 11,0$ | 9,0 | 7,65 | 10 | 1 |

Table 4.06 - Surge Arresters selection according to motors nominal voltage

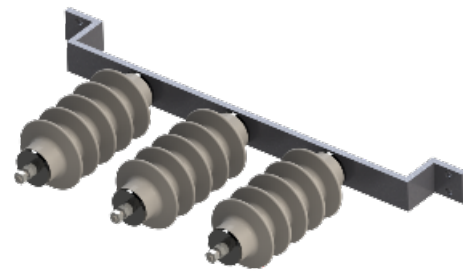

Figure 4.05 - Surge Arresters

Surge Capacitors

Surge Capacitors (or Surge Suppressors), connected in parallel with the Surge Arresters, can be used to increase motor protection against switching and lightning. While Surge Arresters provide a discharge to the ground when the voltage exceeds a determined value (acting on the magnitude of the surge wave), Surge Capacitors control the rise time of the overvoltage wave front, especially in high frequency transient overvoltage surges (acting on the shape of the surge wave).

Both devices provide effective protection against inter-turn insulation failures, eliminating multiple strike transients associated with vacuum and other switchgears, ignition strikes or lightning surges, extending the life of the machine insulation.

On request, W22Xd motors can be supplied with Surge Capacitors connected between the main terminal box phase terminals and the ground (in parallel with Surge Arresters). If nothing required otherwise, WEG uses the following selection of Surge Capacitors:

| Motor nominal voltage (kV) | Rated voltage (kV) | Number of phases | Frequency (Hz) |
|----------------------------|--------------------|------------------|----------------|
| $U \leq 3,3$ | 3,3 | 3 | 50/60 |
| $3,3 < U \leq 6,6$ | 6,6 | 3 | 50/60 |
| $6,6 < U \leq 11,0$ | 11,0 | 3 | 50/60 |

Table 4.07 - Surge Capacitors selection according to motors nominal voltage

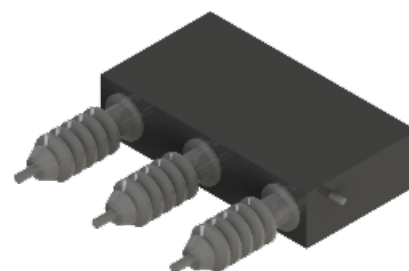

Figure 4.06 - Surge Capacitor

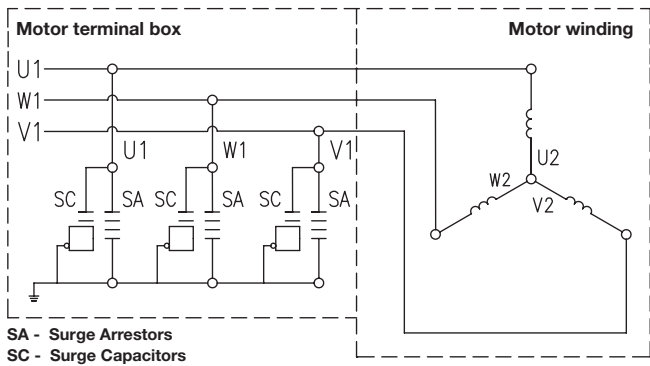

Figure 4.07 - Connection Scheme of Surge Arresters and Surge Capacitors

4.3.1.3. Partial Discharge Monitoring System

The first step for most electric failure in a motor insulation system is the formation of gas-filled voids. These voids are the result of degradation of the impregnation resin. They may be caused by thermal deterioration, load cycling, bonding degradation, loose windings over time, electrical slot discharges, conductive / semiconductive / grading deterioration and contamination. Once a void is formed in the insulation, a potential difference will be generated across it. The magnitude of this voltage will depend upon the applied voltage, the capacitance of the insulation and the gas present in the void. A discharge can only occur when the electric stress (V/mm) exceeds the electrical breakdown point for the gas in a void. When the supplied voltage wave increases sinusoidally, the electric stress across the void increases until it reaches 3kV/mm (air breakdown voltage). The voltage across a void can exceed the breakdown voltage and that breakdown will not occur until a free electron appears within the gap and starts a flow of electrons across it, which generates a very fast current pulse rise time called partial discharge.

As the W22Xd MV/HV motors insulation system contains mica, a discharge resistant material, the degradation is slow. Because of this slow aging process, periodic monitoring of the PD activity makes sense. The rule of thumb regarding the length of time between detection of the PD and the damage, due to a failure mechanism, is several months for 4kV motors, 2-3 years for 6kV motors and 5 years for 11kV motors.

On request, W22Xd MV/HV motors can be equipped with a Partial Discharge Monitoring System from *IRIS Power – Qualitrol*, which comprises:

- Capacitive couplers (Epoxy Mica Capacitors – EMC) connected to the motor terminals (one per phase);
- Coaxial cables to connect EMCs to the Termination Box;
- Termination Box with connection board (or termination board) for data collection.

WEG offers a single-ended installation, with only 3 machine EMC's and a termination box. Customer must assess the installation

requirements and defines if this configuration will be correct or if a double-ended installation is required. For double-ended configurations, as they require 3 more EMC's connected in customer system, a special enquiry must be sent to WEG.

Data can be collected from the Termination Box with a continuous or a portable system. The data collection equipment and data evaluation is out of WEG scope of supply.

EMC's couplers and Termination Board are installed inside of the flameproof enclosures. It is of the customer's responsibility to assure the correct installation system for data collection in respect to the technical requirements of the classified zone.

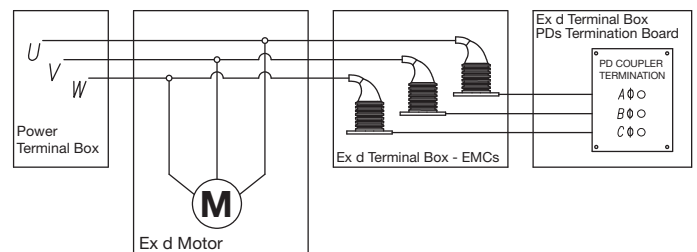

Figure 4.08 - PD connection diagram and configuration in W22Xd MV/HV motors

4.3.1.4. Terminal Boxes with Fault Rate Level

The fault rate level is the short circuit current rating that the terminal box can safely withstand during a specified time. W22Xd MV/HV motor power terminal boxes can be supplied on request with certified fault rate level.

This characteristic combined with the power supply overcurrent protection device can prevent overheating, fire, explosions or other damages inside the enclosure, caused by a short circuit.

These W22Xd MV/HV motor power terminal boxes were tested in accordance with the guidelines of IEC 62271-1 and IEC 62271-200 Standards to withstand the following short circuit current ratings:

| Motor enclosure | Voltage (V) | Fault Rate Level (kA) | Time (s) |
|-----------------|------------------|-----------------------|----------|
| Ex d | 1100 < U ≤ 6600 | 45 | 0,25 |
| | 6600 < U ≤ 11000 | 45 | 0,25 |
| Ex d e | 1100 < U ≤ 6600 | 25 | 0,25 |
| | 6600 < U ≤ 11000 | 25 | 0,25 |

Table 4.08 - Fault rate levels for power terminal boxes

For more information about terminal boxes fault rate levels please consult Section 7 – Terminal Boxes

4.3.2. Auxiliary Protection Equipment

On request, W22Xd motors can be provided with several auxiliary protection equipment.

Below we have the basic principles of some of them.

Pt – 100

These are RTD's (Resistance Temperature Detectors) with operating principle based on the properties that some materials vary the electric resistance with the variation in temperature (usually platinum, nickel or copper). They are fitted with calibrated resistances that vary linearly with temperature, allowing continuous reading of motor operating temperature through a monitoring display, with high precision rate and response sensitivity.

The same detector can serve as alarm (with operation above the regular operating temperature) and trip (usually set up for the maximum temperature of the insulation class).



Thermistor (PTC)

These are thermal protectors consisting of semiconductor detectors with sudden variation of the resistance when reaching a certain temperature.

PTC is considered a thermistor with resistance increasing drastically to a well defined temperature figure. This sudden resistance variation block the PTC current, causing the output relay to operate, and the main circuit switch-off.

The thermistors are of small dimensions, do not wear and have a quicker response if compared to other protectors, although they do not allow continuous monitoring of motor operating temperature.

Together with their electronic circuits, these thermistors provide full protection against overheating caused by overload, under or overvoltage or frequent reversing operations.

Where thermistor protection is required to provide both alarm and trip operation, it is necessary for each phase of the motor winding to be equipped with two sets of appropriately rated thermistors.



Thermocouple

This is a sensor used to measure temperature. It consists of the joining of two dissimilar metals. When the junction of these two metals is cooled or heated a voltage is produced. The voltage is converted into the temperature that we want to measure.

Depending on the metals used and the calibration, there are different types of thermocouples. The most commonly used are Type E, J, K and T, each one with specific temperature range.

Bimetallic thermal protectors - normally closed

These are silver-contact thermal sensors, normally closed, that operate at a certain temperature rise. When their operating temperature decreases, they go back to the original position instantaneously, allowing the silver contact to close again.

The bimetallic thermal protectors are series-connected with the contactor coil, and can be used either as alarm or trip.

Bimetallic thermal protectors - normally open

These are silver-contact thermal sensors, normally open, that operate at certain temperature rise. When their operating temperature decreases, they go back to the original position instantaneously, allowing the silver contact to open again.

The bimetallic thermal protectors are series-connected with the contactor coil, and can be used either as alarm or trip.

Transmitters 4-20mA

The transmitter 4-20mA converts a physical property such as temperature into an electrical signal. This electrical signal is a current proportional to the temperature being measured. In these transmitters, 4mA represents the low end of the measurement range and 20mA represents the high end. Current loops are ideal for data transmission because of their inherent insensitivity to electrical noise and circuit length. It is a very robust sensor and compatible with a number of RTD's (2, 3, 4 wire circuit) and thermocouple sensor types.

4.4. Variable Speed Drive

4.4.1. Considerations regarding rated voltage

For Medium Voltage motors driven by Variable Speed Drive (VSD), the limits indicated in the table 4.09 must be respected.

| Motor rated voltage | Source type | Coil insulation (phase to phase) | | Main insulation (phase to ground) | |
|----------------------------------|-------------|----------------------------------|------------------------------|-----------------------------------|------------------------------|
| | | Peak voltage on motor terminals | dV/dt (*) on motor terminals | Peak voltage on motor terminals | dV/dt (*) on motor terminals |
| 1000V < V _{NOM} ≤ 4160V | Sinusoidal | ≤ 6500V | ≤ 1800V/μs | ≤ 3800V | ≤ 1800V/μs |
| | PWM (**) | ≤ 10300V | ≤ 2700V/μs | ≤ 6000V | ≤ 2700V/μs |
| 4160V < V _{NOM} ≤ 6600V | Sinusoidal | ≤ 10300V | ≤ 2700V/μs | ≤ 6000V | ≤ 2700V/μs |
| | PWM (**) | ≤ 15400V | ≤ 4000V/μs | ≤ 9000V | ≤ 4000V/μs |

Table 4.09 - Medium Voltage Motors VSD criteria

(*) Definition according to NEMA MG1 - Part 30.

(**) Reinforced insulation for VSD operation.

Notes:

1. The switching frequency must be limited to 5kHz. Switching frequencies above that, accelerate the winding aging process and might damage the bearings.
2. If one of the above conditions is not followed accordingly (including the switching frequency), an output filter (load reactor) must be installed on the output of the VSD.

For VSD applications, the customer must connect the windings thermal protection to guarantee the limits of surface temperature.

W22Xd Medium Voltage motors in Ex d e execution are equipped with an increased terminal box for voltages above 4.16kV and limited to 6.6kV, in order to guarantee the safe clearances and creepages between the conductive parts.

4.4.2. Torque restrictions on variable speed drive applications

Induction motors driven by frequency inverters may present a higher temperature rise than when supplied with sinusoidal voltage. This temperature rise results from two combined factors: the losses increase due to the PWM harmonics supplied by the VSD and the reduction of the ventilation performance, experienced by self-ventilated motors when operating at low frequencies.

The ventilation restriction can be overpassed by using a forced ventilation unit, specially on low speeds, that ensures a constant air flow over the motor.

Based on exact absorbed power and torque application it is necessary to derate the motor according to the figure 4.09.

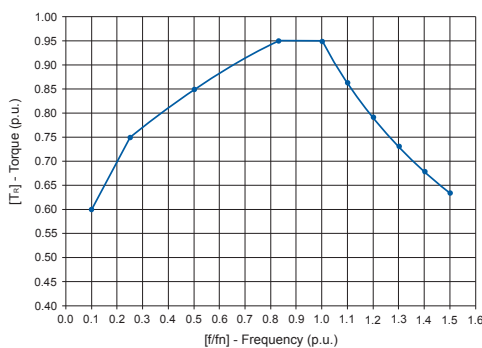

Figure 4.09 - Derating curve for constant flux

| Derating factor to maintain temperature rise of sinusoidal supply* | |
|--|--------------------------|
| Limited by | Apply this equation |
| $0,10 \leq f/fn < 0,25$ | $Tr = (f/fn) + 0,50$ |
| $0,25 \leq f/fn < 0,50$ | $Tr = 0,40(f/fn) + 0,65$ |
| $0,50 \leq f/fn < 0,83$ | $Tr = 0,30(f/fn) + 0,70$ |
| $0,83 \leq f/fn \leq 1,0$ | $Tr = 0,95$ |
| $f/fn > 1,0$ | $Tr = 0,95(f/fn)$ |

Table 4.10 - Derating factors for VSD

(*) The motor temperature rise with the variable frequency drive will be the same as when driven by sinusoidal source. In other words, class F insulation motors with class B temperature rise will remain with class B temperature rise (≤ 80 K) even when driven by a variable frequency drive.

Notes:

1. The derating curve given in figure 4.09 is related to the temperature on motor winding and thermal class. This curve do not consider thermal tolerance factor of the motors. It is intended to show the torque limitations for variable frequency drive motors.
2. W22Xd medium and high voltage flameproof motors can be designed to operate with VSD and with the winding temperature rise ≤ 105 K, maintaining T4 surface temperature (135°C). Please refer to WEG for motors selection in this condition.
3. Maximum allowable speeds can be found at 4.4.6..

4.4.3. Forced ventilation kit

For the cases where independent cooling system is required, W22Xd motors can be supplied with a forced ventilation kit, as shown in figure 4.10.

This unit is composed of an electric motor with the same certification of the main motor, fed directly from the net power supply, providing a constant air flow over the main motor regardless of the application speed.

The main motor can only be operated when the forced cooling motor is running.

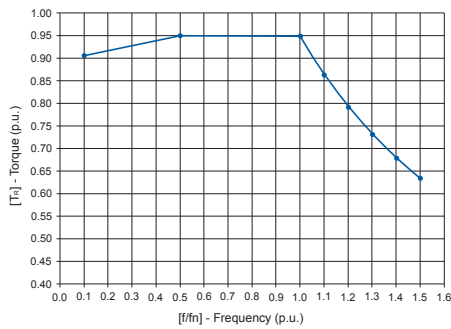

Figure 4.10 - Derating curve for motors equipped with a forced ventilation kit

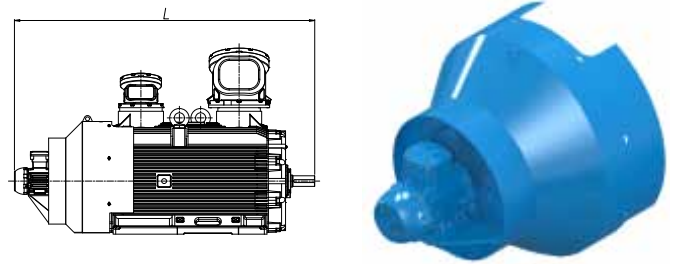

Figure 4.11 - Rib-cooled motor with forced ventilation kit

| Derating factor to maintain temperature rise of sinusoidal supply* | |
|--|------------------------|
| Limited by | Apply this equation |
| $0.1 \leq f/fn < 0.50$ | $Tr = 0.1(f/fn) + 0.9$ |
| $0.50 \leq f/fn \leq 1.0$ | $Tr = 0.95$ |
| $f/fn > 1.0$ | $Tr = 0.95/(f/fn)$ |

Table 4.11 - Derating factors for VSD with forced ventilation kit

(*) The motor temperature rise with the variable frequency drive will be the same as when driven by sinusoidal source. In other words, class F insulation motors with class B temperature rise will remain with class B temperature rise ($\leq 80K$) even when driven by a variable frequency drive.

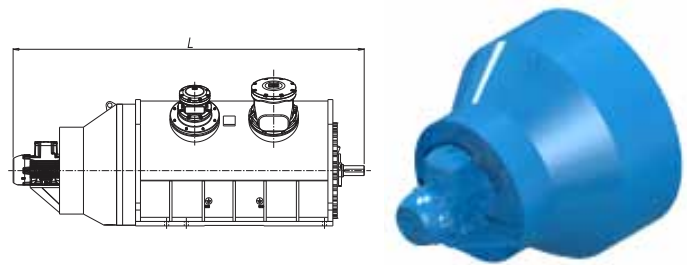

Figure 4.12 - Tube-cooled motor with forced ventilation kit

The total motor length increases with the inclusion of the forced ventilation kit as per table 4.12 and 4.13, considering ambient temperature from $-20^{\circ}C$ up to $40^{\circ}C$ and altitude up to 1000 m.a.s.l.

WEG can supply alternative forced ventilation on request.



| Frame | Gas group | Poles | Total motor length - L (mm) | | Forced ventilation kit | | | | | |
|--------|------------------|-------------------|-----------------------------|-------------------------|------------------------|-------------------------|-----|-------------------------|-----|------|
| | | | Without forced ventilation | With forced ventilation | Poles | V (50Hz) ⁽¹⁾ | kW | V (60Hz) ⁽¹⁾ | kW | IM |
| 315L | I M2 / IIB / IIC | 2P | 1512 | 1855 | 4 | 380-415/ 660-690 | 1,5 | 440-460 | 1,8 | 1001 |
| | | 4P+ | 1542 | 1885 | | | | | | |
| 355M/L | I M2 / IIB / IIC | 2P | 1576 | 1963 | 4 | 380-415/ 660-690 | 2,2 | 440-460 | 2,6 | 1001 |
| | | 4P+ | 1646 | 2033 | | | | | | |
| 355A/B | I M2 / IIB / IIC | 2P | 1784 | 2171 | 4 | 380-415/ 660-690 | 2,2 | 440-460 | 2,6 | 1001 |
| | | 4P+ | 1854 | 2241 | | | | | | |
| 400L/J | I M2 / IIB / IIC | 2P | 1994 | 2381 | 4 | 380-415/ 660-690 | 3 | 440-460 | 3,6 | 1001 |
| | | 4P+ | 2034 | 2421 | | | | | | |
| 400G | I M2 / IIB / IIC | 2P | 2234 | 2621 | 4 | 380-415/ 660-690 | 3 | 440-460 | 3,6 | 1001 |
| | | 4P+ | 2274 | 2661 | | | | | | |
| 450K/H | I M2 / IIB / IIC | 2P | 2230 | 2617 | 4 | 380-415/ 660-690 | 3 | 440-460 | 3,6 | 1001 |
| | | 4P+ | 2271 | 2658 | | | | | | |
| 500K/H | I M2 / IIB / IIC | 2P ⁽²⁾ | 2750 | 3137 | 4 | 380-415/ 660-690 | 3 | 440-460 | 3,6 | 1001 |
| | | 4P+ | 2830 | 3217 | | | | | | |

| Frame | Gas group | Poles | Total motor length - L (mm) | | Forced ventilation kit | | | | | |
|--------|------------------|-------|-----------------------------|-------------------------|------------------------|-------------------------|----|-------------------------|-----|------|
| | | | Without forced ventilation | With forced ventilation | Poles | V (50Hz) ⁽¹⁾ | kW | V (60Hz) ⁽¹⁾ | kW | IM |
| 560H/G | I M2 / IIB / IIC | 4P+ | 2830 | 3236 | 4 | 380-415/ 660-690 | 4 | 440-460 | 4,8 | 1001 |

Table 4.12 - Main motor dimensions with forced ventilation kit for W22Xd rib-cooled

| Frame | Gas group | Poles | Total motor length - L (mm) | | Forced ventilation kit | | | | | |
|--------|------------------|-------------------|-----------------------------|-------------------------|------------------------|-------------------------|-----|-------------------------|----|------|
| | | | Without forced ventilation | With forced ventilation | Poles | V (50Hz) ⁽¹⁾ | kW | V (60Hz) ⁽¹⁾ | kW | IM |
| 560J/H | I M2 / IIB / IIC | 2P ⁽²⁾ | 2835 | 3286 | 4 | 380-415/ 660-690 | 7,5 | 440-460 | 9 | 1001 |
| | | 4P+ | 2875 | 3326 | | | | | | |
| 560H/G | I M2 / IIB / IIC | 2P ⁽²⁾ | 2965 | 3416 | 4 | 380-415/ 660-690 | 7,5 | 440-460 | 9 | 1001 |
| | | 4P+ | 3005 | 3456 | | | | | | |
| 630K/J | I M2 / IIB / IIC | 2P ⁽²⁾ | 2870 | 3321 | | | | | | |
| | | 4P+ | 2910 | 3361 | | | | | | |
| 630J/H | I M2 / IIB / IIC | 2P ⁽²⁾ | 2970 | 3421 | | | | | | |
| | | 4P+ | 3010 | 3461 | | | | | | |
| 710K/J | I M2 / IIB / IIC | 2P ⁽²⁾ | 2950 | 3401 | 4 | 380-415/ 660-690 | 7,5 | 440-460 | 9 | 1001 |
| 710J/H | I M2 / IIB / IIC | 4P+ | 3310 | 3761 | | | | | | |
| 710H/G | I M2 / IIB / IIC | 4P+ | 3630 | 4081 | | | | | | |

Table 4.13 - Main motor dimensions with forced ventilation kit for W22Xd for tube-cooled

(1) Standard voltage. Other executions available on request.
 (2) Maximum allowable operating frequency: 50Hz.

4.4.4. Encoders

For an accurate application control an encoder is typically used. Encoders are direct coupled to a motor shaft extension and fixed in the external part of fan cover grid.

Encoders must be certified at least with the same protection level as the main motor.



Figure 4.13 - Encoder position example

4.4.5. Bearing insulation

In order to avoid current in the bearings, in VSD applications, special bearing arrangements have to be considered. The WEG solution in W22Xd Medium and High Voltage flameproof motors is to use insulated bearings and internal shaft grounding rings. Motors intended to be used with VSD application must have the following features.

| Range | Frame size | Standard | Optional |
|-------|------------|--|---|
| W22Xd | 315-400 | Non drive end insulated bearing | Drive and non drive end insulated bearings + drive and non drive end endshields grounding rings |
| | 450-710 | Non drive end insulated bearing + drive end endshield grounding ring | Drive and non drive end insulated bearings + drive and non drive end endshields grounding rings |

Table 4.14 - Bearings protection for VSD driven motors

| Frame | W22Xd tube-cooled MV/HV motors | | | |
|--------|--------------------------------|---------------|---------------|---------------|
| | 2 poles (rpm) | 4 poles (rpm) | 6 poles (rpm) | 8 poles (rpm) |
| 710K/J | 3000 | NA | NA | NA |
| 710J/H | NA | 1800 | 1800 | 1500 |
| 710H/G | | 1800 | 1800 | 1500 |

Table 4.16 - Maximum safe operating speeds (rpm) for W22Xd tube-cooled MV and HV motors

Notes:

1. The values specified in Table 4.15 and 4.16 are related to mechanical limitations. For operation above the nameplate speed, the electrical limitations (motor torque capability) must be also considered.
2. Operation above nameplate speed may require special accurate motor balancing.
3. Bearing life will be affected by the duration that the motor is operated at various speeds.
4. For speeds and ratings not covered by the Table 4.15 and 4.16, please contact WEG.
5. For sleeve bearings please refer to us.

4.4.6. Operating speed

For VSD operation motors, the speed ranges must be confirmed. Depending on the operation speed, restriction can arise from bearings/sleeve bearings maximum peripheral speed, from rotational parts or due to rotor natural frequencies.

Please refer to the maximum limits for safe operation specified in Tables 4.15 and 4.16, for standard bearing executions.

| Frame | W22Xd rib-cooled MV/HV motors | | | |
|--------|-------------------------------|---------------|---------------|---------------|
| | 2 poles (rpm) | 4 poles (rpm) | 6 poles (rpm) | 8 poles (rpm) |
| 315L | 4200 | 2700 | 2000 | 1500 |
| 355M/L | 3780 | 2250 | 2000 | 1500 |
| 355A/B | 3780 | 2250 | 2000 | 1500 |
| 400L/J | 3600 | 2100 | 2000 | 1500 |
| 400G | 3600 | 2100 | 2000 | 1500 |
| 450K/H | 3600 | 1950 | 2000 | 1500 |
| 500K/H | 3000 | 1800 | 1500 | 1500 |
| 560H/G | O/R | 1800 | 1500 | 1500 |

Table 4.15 - Maximum safe operating speeds (rpm) for W22Xd rib-cooled MV and HV motors

4.5. Duty Cycles

The different duty types are defined according to IEC/EN 60034-1 Standard.

Duty types are the different degrees of load regularity at which the motor is submitted. It is customer responsibility to choose the duty.

The duty type shall be designated by the appropriate abbreviation, written after the load value. When customer does not declare a duty, the manufacturer considers S1 for duty type (continuous running duty).

For W22Xd motors duty cycles others than S1 please consult WEG prior to order.

| Frame | W22Xd tube-cooled MV/HV motors | | | |
|--------|--------------------------------|---------------|---------------|---------------|
| | 2 poles (rpm) | 4 poles (rpm) | 6 poles (rpm) | 8 poles (rpm) |
| 560J/H | 3000 | 1800 | 1800 | 1500 |
| 560H/G | 3000 | 1800 | 1800 | 1500 |
| 630K/J | 3000 | 1800 | 1800 | 1500 |
| 630J/H | 3000 | 1800 | 1800 | 1500 |



S1- Continuous running duty

Operation at a constant load maintained for sufficient amount of time for thermal equilibrium to be reached.

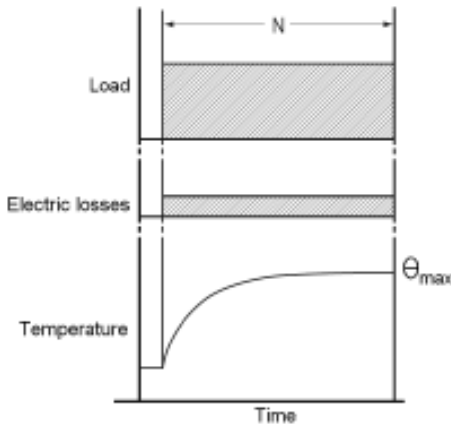

Figure 4.14 - Duty type S1

S2- Short-time duty

Operation at a constant load during a standard time, less than that required to reach thermal equilibrium. Followed by a rest period long enough until winding has cooled down to the ambient temperature.

Operating times of 10, 30, 60 or 90 minutes are recommended.

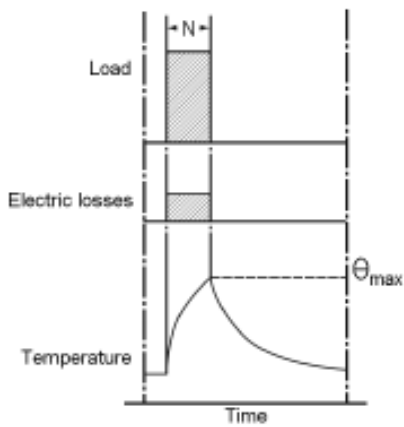

Figure 4.15 - Duty type S2

The table 4.17 shows the overload values, considering a heating time constant of 20 min.

| Operating time (in minutes) | P (Maximum power allowed) / P _n (Nominal power) (Overload) |
|-----------------------------|---|
| 10 | 1,6 |
| 30 | 1,13 |
| 60 | 1,03 |
| 90 | 1 |

Table 4.17 - Overload values

S3- Intermittent periodic duty

Operation with a sequence of identically cycles, each one included a functioning period with a constant load and a rest period. In period of functioning the maximum temperature can be reached. Starting current does not affect the temperature rise. Duty Cycle should have 10 minutes, unless exist other indications. The duration factor of cycles is 15, 25, 40 and 60% recommended.

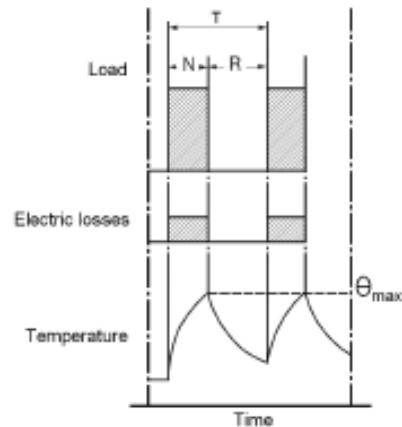

Figure 4.16 - Duty type S3

$$\text{cyclic duration factor} = \frac{N}{T} \times 100\%$$

S4- Intermittent periodic duty with starting

Operation with sequence of identical duty cycles, each one included different periods: start up, functioning with constant load and a rest period. Current of start up affects temperature rise. Details relative of the number of cycles (starts per hour) and inertia constant must also be known.

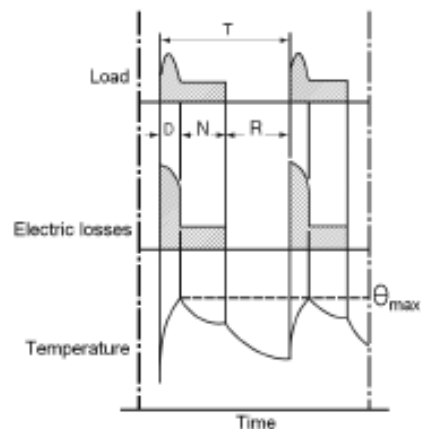

Figure 4.17 - Duty type S4

$$\text{cyclic duration factor} = \frac{(D+N)}{T} \times 100\%$$

S5- Intermittent periodic duty with electrical braking

Similar operation to S4, having electric braking of the machine, which influences on the temperature rise. Starting current also affects temperature rise, the details relative the number of cycles (starts per hour) and inertia constant must also be known.

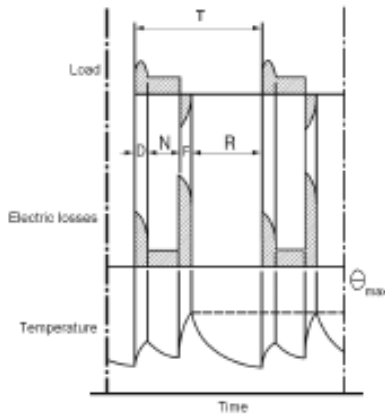

Figure 4.18 - Duty type S5

$$\text{cyclic duration factor} = \frac{(D+N+F)}{T} \times 100\%$$

S6- Continuous running duty with intermitted load

Similar operation to S3, but without the resting period - instead it works continuously without load. Starting current does not affect the temperature rise.

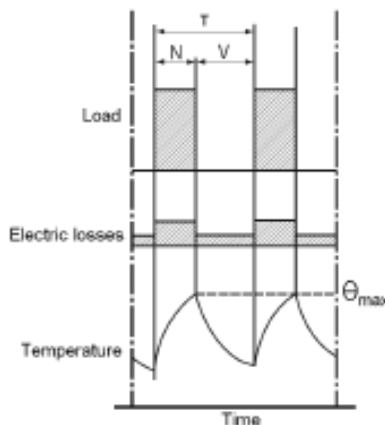

Figure 4.19 - Duty type S6

$$\text{cyclic duration factor} = \frac{N}{N+V} \times 100\%$$

S7- Continuous running duty with electrical braking

Motor works continuously with periods of start up, braking and constant load. This operation is very demanding to the motor.

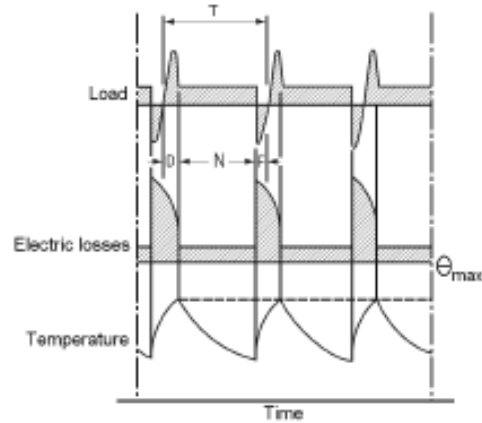

Figure 4.20 - Duty type S7

cyclic duration factor = 1

S8- Continuous running duty with periodic change of load/speed

Sequence of identical duty cycles, each one contained a time of operation at constant load determined by speed rotation. The alteration of speed only exists with pole amplitude modulated motors.

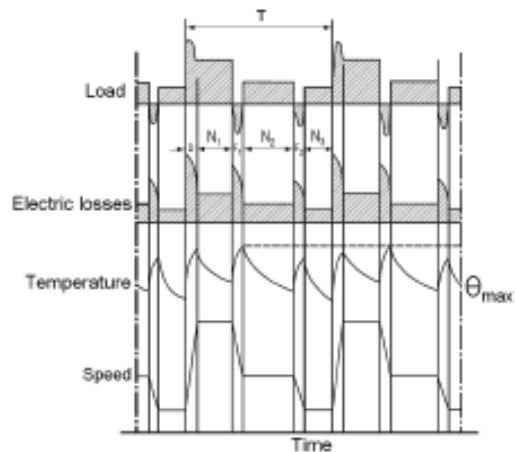

Figure 4.21 - Duty type S8

cyclic duration factor =

$$\frac{D+N_1}{D+N_1+F_1+N_2+F_2+N_3} \times 100\%$$

$$\frac{F_1+N_2}{D+N_1+F_1+N_2+F_2+N_3} \times 100\%$$

$$\frac{F_2+N_3}{D+N_1+F_1+N_2+F_2+N_3} \times 100\%$$



S9- Duty with non periodic variations of load and speed

Duty with non-periodic load and speed variations. It's possible to apply overload which can exceed the reference load. Duty type S1 is used like a reference value to determinate the overloads.

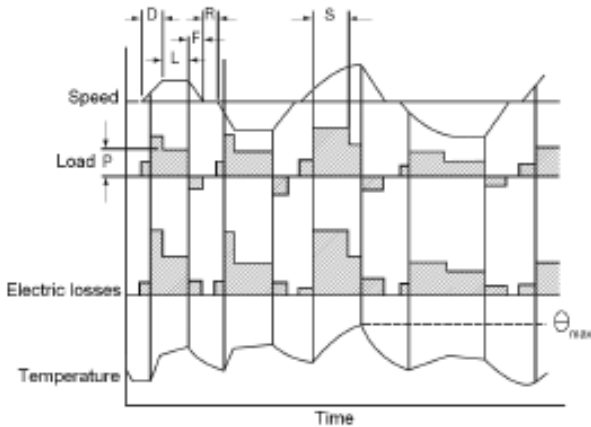

Figure 4.22 - Duty type S9

S10- Operation with discrete constant loads

Duty S10 consists in specific number of discrete values of load. Load and speed variations are proportional. The combination of these two should be maintained for sufficient time to thermal equilibrium of the machine to be reached. It's not necessary that each load cycle be exactly the same.

The minimum load within cycle may have the value zero (no-load or at rest). Duty type S1 is used like a reference value to determinate the overloads.

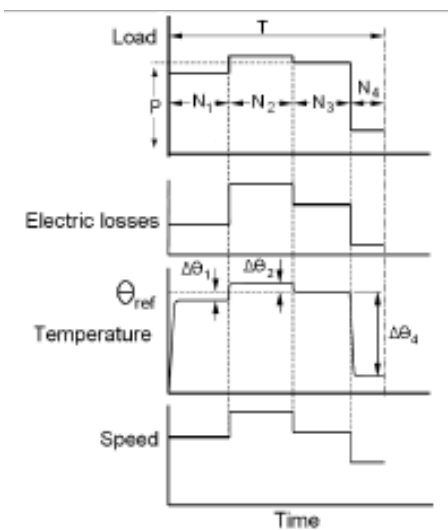

Figure 4.23 - Duty type S10

| | |
|------------------|---|
| D | Start-up or acceleration time |
| F, F1, F2 | Electric Braking time |
| N, N1, N2, N3 | Constant load operating time |
| T | Time of one load cycle |
| L | Variable load operating time |
| V | No-load operating time |
| R | Rest time |
| S | Overload operating time |
| P | Full load |
| θ_{max} | Maximum temperature reached during cycle |
| θ_{ref} | Temperature at reference load based on duty type S1 |
| $\Delta\theta_i$ | Difference between temperature rise of the winding at each of the various loads within one cycle and the temperature rise based on duty cycle S1 with reference load. |

Table 4.18 - Simbology

4.6. Efficiency Levels

In WEG's pursuit of a conscientious and efficient use of energy, to assure the sustainability and environmental protection, W22Xd Medium and High Voltage flameproof motors present some of the highest efficiency levels available on the market.

4.7. Main Electrical Connections

Standard W22Xd Medium Voltage motors with rated current $\leq 630A$ have always 3 terminals for supply cables connection inside of main terminal box WTBX M.

For current line $> 630A$, 6 terminals executions are used inside of main terminal box WTBX L.

Standard W22Xd High Voltage motors have always 3 terminals available for supply cables connection inside main terminal box WTBX L. The maximum allowed rated current is 400A.

Medium and High Voltage flameproof motors are always star connected.

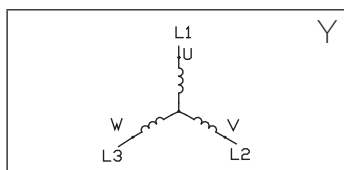

Figure 4.24 - Star connection (MV or HV)

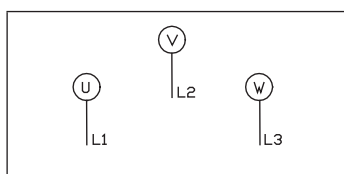

Figure 4.25 - Star connection terminal block arrangement for MV or HV (3 terminals)

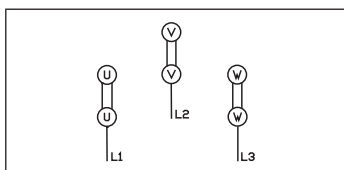

Figure 4.26 - Star connection terminal block arrangement for MV (6 terminals)

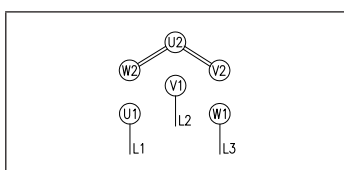

Figure 4.27 - Star connection terminal block arrangement for MV with neutral point in the same terminal box

4.8. Tolerances for Electrical Data

The following tolerances are allowed in accordance with IEC/EN 60034-1 Standard:

| | |
|-----------------------|---|
| Efficiency (η) | -15% (1- η) for $P_{nom} \leq 150$ kW / -10% (1- η) for $P_{nom} > 150$ kW |
| Power factor | -1/6(1-cos ϕ) Minimum Absolute 0,02 and Maximum Absolute 0,07 |
| Slip | $\pm 20\%$ for $P_{nom} \geq 1$ kW $\pm 30\%$ for $P_{nom} < 1$ kW |
| Starting current | +20% (without lower limit) |
| Starting torque | -15% +25% |
| Breakdown torque | -10% |
| Moment of inertia | $\pm 10\%$ |

Table 4.19 - Tolerances for electrical data

Standard and Optional Features

| | |
|--|-----------|
| 5.1. Standard Features - Rib-Cooled Motors | 79 |
| 5.2. Optional Features - Rib-Cooled Motors | 81 |
| 5.3. Standard Features - Tube-Cooled Motors | 87 |
| 5.4. Optional Features - Tube-Cooled Motors | 89 |

5. Standard and Optional Features

5.1. Standard Features - Rib-cooled Motors

| Line | | W22Xd | | | | | | | | |
|--------------------------------|--------------------------------|---|--|--------|--|--|---|---------------------|---------------------|------------|
| Frame | | 315L | 355M/L | 355A/B | 400L/J | 400G | 450K/H | 500K/H | 560H/G | |
| General features | | | | | | | | | | |
| Nameplate markings | | ATEX | | | | | | | | |
| Certification marking | | Ex d(e) IIB T4 Gb / Ex d(e) IIC T4 Gb / Ex d(e) I Mb / Ex tb IIIC T125°C Db IP6X (associated with IIB or IIC) | | | | | | | | |
| Ambient temperature | | -20°C up to +40°C | | | | | | | | |
| Mechanical features | | | | | | | | | | |
| Mounting | | B3T | | | | | | | | |
| Frame | Material | Cast Iron FC-200 (EN-GJL-200) | | | | | | | Steel | |
| Degree of protection | | IP55 - Ex d(e) IIB/IIC T4 Gb IP65 - Ex tb IIIC T125°C Db IP6X IP66 - Ex d(e) I Mb | | | | | | | | |
| Grounding | | Double grounding in the frame + Three grounding in the terminal box (two internal and one external) | | | | | | | | |
| Cooling method | | Totally enclosed fan cooled - IC411 | | | | | | | | |
| Fan | Material | 2P | Cast iron | | | | Aluminium (Ex d(e) IIB/IIC T4 Gb / Ex tb IIIC T125°C Db IP6X) Steel (Ex d(e) I Mb) | | | |
| | | 4 - 8P | Cast iron | | | | Steel | | | |
| Fan cover | Material | Steel | | | | | | | | |
| Endshields | Material | Cast iron FC-200 (EN-GJL-200) | | | | | | | Steel | |
| Bearings | Clearance D.E | | C3 | | | | | | | |
| | Clearance N.D.E | | C3 | | | | | | | |
| | Locating bearing configuration | 2P | DE bearing locked with inner and outer bearing caps and fitted with pre-load springs in the NDE bearing | | | | | | | |
| | | 4 - 8P | Ball and roller bearings arrangement: DE and NDE bearings locked with inner and outer bearing caps | | | | | | | |
| | Drive end | 2P | 6314 | 6316 | 6316 | 6318 | 6318 | 6318 | NU220+6020 | OR |
| | | 4 - 8P | 6319 | 6322 | 6322 | 6324 | 6324 | 6326 | 6328 ⁽¹⁾ | NU328+6328 |
| Non drive end | 2P | 6314 | 6316 | 6316 | 6318 | 6318 | NU218 | NU220 | OR | |
| | 4 - 8P | 6316 | 6319 | 6319 | 6324 | 6324 | 6326 | 6328 ⁽¹⁾ | NU328 | |
| Bearing seal | | 2P | WSeal - Ex d(e) IIB/IIC T4 Gb (nitrilic rubber) Labyrinth Seal - Ex tb IIIC T125°C Db IP6X W3Seal - Ex d(e) I Mb | | | Labyrinth Seal - Ex d(e) IIB/IIC T4 Gb / Ex tb IIIC T125°C Db IP6X W3Seal - Ex d(e) I Mb | | | | |
| | | 4 - 8P | | | | V-ring Seal - Ex d(e) IIB/IIC T4 Gb (nitrilic rubber) Labyrinth Seal - Ex tb IIIC T125°C Db IP6X W3Seal - Ex d(e) I Mb | | | | |
| Lubrication | Type of grease | Polyrex EM (Esso Mobil) | | | | | | | | |
| | Grease fitting | With grease fittings in DE and NDE bearings | | | | | | | | |
| Sleeve Bearings ⁽²⁾ | Axial float | 6mm (±3mm) | | | | | | | | |
| | Locating bearing configuration | Located DE bearing | | | | | | | | |
| | 2P | 9 - 80 | | | NA | | 9 - 80 | | | |
| | 4 - 8P | 11 - 110 | | | | 11 - 125 | | | | |
| Main cables connection | MV | I ≤ 315A: 3 x M12 conductor bushings (plus conductor clamps for Ex e terminal boxes execution) - WTBX M terminal box 315A < I ≤ 400A: 3 x M16 conductor bushings (plus conductor clamps for Ex e terminal boxes execution) - WTBX M terminal box 400A < I ≤ 630A: 3 x M20 conductor bushings (plus conductor clamps for Ex e terminal boxes execution) - WTBX M terminal box 630A < I ≤ 800A: 6 x M16 conductor bushings (plus conductor clamps for Ex e terminal boxes execution) - WTBX L terminal box 800A < I ≤ 1260A: 6 x M20 conductor bushings (plus conductor clamps for Ex e terminal boxes execution) - WTBX L terminal box | | | | | | | | |
| | HV | NA | | | I ≤ 400A: 3 x M16 conductor bushings (plus conductor clamps for Ex e terminal boxes execution) | | | | | |
| Terminal Boxes | Material | Cast iron FC-200 (EN-GJL-200) | | | | | | | | |
| Auxiliary terminal box | | 1 x WTBX XS | | | 1 x WTBX S | | | | | |

| Line | | | W22Xd | | | | | | | |
|----------------------------------|------------------------|--------|---|--------|--------|---|-----------------------|---------------------------------------|--------|--------|
| Frame | | | 315L | 355M/L | 355A/B | 400L/J | 400G | 450K/H | 500K/H | 560H/G |
| Leads inlet | Main terminal box | MV | I ≤ 315A: 1 x M63 x 1,5 315A < I ≤ 630A: 3 x M63 x 1,5 630A < I ≤ 1260A: 6 x M63 x 1,5 | | | | | | | |
| | | HV | NA | | | I ≤ 200A: 1 x M63 x 1,5 200 < I ≤ 400A: 3 x M50 x 1,5 | | | | |
| | Auxiliary terminal box | MV | 3 x M20 x 1,5 | | | | | | | |
| | | HV | NA | | | 3 x M20 x 1,5 | | | | |
| | Plug | | Main terminal box: 1 x plastic plug (other entrances with nickel plated brass certified plugs) Auxiliary terminal box: 3 x nickel plated brass certified plugs | | | | | | | |
| Joint seal | | | Without (only machined surfaces) | | | | | | | |
| Joints anti-corrosion protection | | | Polyrex EM (Esso Mobil) | | | | | | | |
| Bolts class | Enclosure parts | | 12.9 - Ex d(e) IIB/IIC T4 Gb / Ex tb IIIC T125°C Db IP6X A4-80 - Ex d(e) I Mb | | | | | | | |
| | Other parts | | 8.8 - Ex d(e) IIB/IIC T4 Gb / Ex tb IIIC T125°C Db IP6X A4-80 - Ex d(e) I Mb | | | | | | | |
| Shaft (& keys) | Material | | AISI 4140 | | | | | | | |
| | Threaded hole | 2P | DS M20 | DS M20 | DS M20 | DS M20 | DS M20 | DS M20 | DS M24 | DS M24 |
| | | 4 - 8P | DS M20 | DS M24 | DS M24 | DS M24 | DS M24 | DS M24 | DS M24 | DS M24 |
| Vibration | | | Grade A | | | | | | | |
| Provision for vibration sensors | | | With (1 x M8 x 1,25 on D.E. and N.D.E. end shield at 12 o'clock position) | | | | | | | |
| Balance | | | With half key | | | | | | | |
| Nameplate | Material | | Stainless steel AISI 304 | | | | | | | |
| Painting | Plan | | 202P | | | | | | | |
| | Colour | | Ex d(e) IIB/IIC T4 Gb: RAL5009 / Ex d(e) I Mb: RAL2003 | | | | | | | |
| Tropical treatment | | | Alkyd resin based varnish painting in rotor, windings, frame (internal), endshields (internal), terminal boxes (internal) and bearing caps (internal) | | | | | | | |
| Electrical features | | | | | | | | | | |
| Voltage | | | MV (up to 6600V) | | | MV (up to 6600V) HV (up to 11000V) - OR | | MV (up to 6600V) HV (up to 11000V) | | |
| Frequency | | | 50 Hz | | | | | | | |
| Winding | Copper wire | | Bare copper with mica tape insulation | | | | | | | |
| | Insulation materials | | depending on voltage level, a combination of mica tapes, conductive tapes, semi-conductive tapes and polyester shrinking tapes can be used | | | | | | | |
| | Impregnation | | VPI | | | | | | | |
| | Stator cables | | Copper with silicone insulation and fiber glass braid | | | | | | | |
| | Insulation class | | F (DT 80K) | | | | | | | |
| Service factor | | | 1.00 | | | | | | | |
| Rotor | | | Aluminium die cast ⁽³⁾ | | | | Copper ⁽⁴⁾ | | | |
| Thermal protector | Stator winding | | MV: Pt100, 2 per phase (3 wires) in coil heads, connected in the auxiliary terminal box. HV: NA | | | MV: Pt100, 2 per phase (3 wires) in coil heads, connected in the auxiliary terminal box. HV: Pt100, 2 per phase (3 wires) in the slots, connected in the auxiliary terminal box. | | | | |
| | Bearings | | Pt100, 1 per bearing (3 wires), connected in the auxiliary terminal box | | | | | | | |
| Space heaters | Use | | Standard, connected in the auxiliary terminal box | | | | | | | |
| | Voltage | | 230V | | | | | | | |
| | Power | | 140W | 174W | 174W | 300W | 300W | 400W | 500W | 600W |

Notes:

- (1) - For the higher outputs the standard bearings arrangement is: Drive end: NU328+6328 / Non drive end: NU328
- (2) - As optional for Ex d(e) IIB T4 Gb / Ex d(e) I Mb motors
- (3) - Some standard motors have copper rotors in frame 400L/J (see Section 6 - Electrical and Mechanical Data)
- (4) - Some standard motors have aluminium rotors in frame 400G (see Section 6 - Electrical and Mechanical Data)
- S - Standard
- O - Optional
- NA - Not Applicable
- OR - On Request

5.2. Optional Features - Rib-Cooled Motors

| Line | | W22Xd | | | | | | | |
|---|--|-------|--------|------------------|------------------|------------------|--------|--------|--------|
| Frame | | 315L | 355M/L | 355A/B | 400L/J | 400G | 450K/H | 500K/H | 560H/G |
| General optional | | | | | | | | | |
| Nameplate markings | ATEX | S | S | S | S | S | S | S | S |
| | IECEX | O | O | O | O | O | O | O | O |
| | EAC Ex (Russia, Belarus, Kazakhstan) | O | O | O | O | O | O | O | O |
| | SITIAS - NEPSI (China) | OR | OR | OR | OR | OR | OR | OR | OR |
| | CSA _{US} (Canada, USA) | OR | OR | OR | OR | OR | OR | OR | OR |
| | Inmetro (Brazil) | O | O | O | O | O | O | O | OR |
| | PESO / CCOE (India) | O | O | O | O | O | O | O | OR |
| | SONCAP (Nigeria) | O | O | O | O | O | O | O | O |
| Ambient temperature | - 20°C up to +40°C | S | S | S | S | S | S | S | S |
| | - 40°C up to +40°C | O | O | O | O | O | O | O | O |
| | - 55°C up to +40°C | OR | OR | OR | OR | OR | OR | OR | OR |
| | - 20°C up to +50°C | O | O | O | O | O | O | O | O |
| | - 20°C up to +60°C | O | O | O | O | O | O | O | O |
| Mechanical optional | | | | | | | | | |
| Mounting | | | | | | | | | |
| B3L / B3R / B35T / B35L / B35R | | O | O | O | O | O | O | O | O |
| B5T / B5L / B5R | | O | O | O ⁽¹⁾ | O ⁽¹⁾ | O ⁽¹⁾ | NA | NA | NA |
| V1 / V5 / V15 / V3 / V6 / V36 | 2P | O | O | O | O | O | NA | NA | NA |
| | 4 - 8P | O | O | O | O | O | O | O | O |
| Frame | | | | | | | | | |
| Material | FC-200 (EN-GJL-200) | S | S | S | S | S | S | S | NA |
| | FE-400 (EN-GJS-400) | O | O | O | O | O | O | O | NA |
| | Steel | O | O | O | O | O | O | O | S |
| Endshields | | | | | | | | | |
| Material | FC-200 (EN-GJL-200) | S | S | S | S | S | S | S | NA |
| | FE-400 (EN-GJS-400) | O | O | O | O | O | O | O | NA |
| | Steel | O | O | O | O | O | O | O | S |
| Main terminal box | | | | | | | | | |
| Material | FC-200 (EN-GJL-200) | S | S | S | S | S | S | S | S |
| | FE-400 (EN-GJS-400) | O | O | O | O | O | O | O | O |
| | Steel | O | O | O | O | O | O | O | O |
| Gland plate (for main terminal box) | Ex d | O | O | O | O | O | O | O | O |
| | Ex e | O | O | O | O | O | O | O | O |
| External and internal grounding | | S | S | S | S | S | S | S | S |
| Fault rate level terminal box (Ex d) ⁽¹⁾ | Up to 6.6kV: 45kA/0,25s | O | O | O | O | O | O | O | O |
| | Up to 11kV: 45kA/0,25s | NA | NA | NA | O | O | O | O | O |
| Fault rate level terminal box (Ex e) ⁽¹⁾ | Up to 6.6kV: 25kA/0,25s | O | O | O | O | O | O | O | O |
| | Up to 11kV: 25kA/0,25s | NA | NA | NA | O | O | O | O | O |
| 2nd main terminal box for neutral connection | | O | O | O | O | O | O | O | O |
| Phase segregated terminal box (Ex e) ⁽¹⁾ - Up to 11kV: 44kA/0,25s | | O | O | O | O | O | O | O | O |
| Phase insulated terminal box (Ex e) ⁽¹⁾ - Up to 6.6kV: 26,3kA/0,25s | | O | O | O | O | O | O | O | O |

| Line | | W22Xd | | | | | | | |
|---|---------------------|------------------|------------------|------------------|------------------|------------------|---------------------|---------------------|---------------------|
| Frame | | 315L | 355M/L | 355A/B | 400L/J | 400G | 450K/H | 500K/H | 560H/G |
| WTBX L Phase insulated terminal box (Ex e) ⁽¹⁾ - Up to 11kV: 50kA/1s | | O | O | O | O | O | O | O | O |
| WTBX L power terminal box with neutral point (6 terminals) | | O | O | O | O | O | O | O | O |
| Main cables connection | | | | | | | | | |
| MV - Six conductor bushings | | O ⁽²⁾ | O ⁽²⁾ | O ⁽²⁾ | O ⁽²⁾ | O ⁽²⁾ | O ⁽²⁾ | O ⁽²⁾ | O ⁽²⁾ |
| HV - Six conductor bushings | | NA | NA | NA | NA | NA | NA | NA | NA |
| Auxiliary terminal boxes | | | | | | | | | |
| Material | FC-200 (EN-GJL-200) | S | S | S | S | S | S | S | S |
| | FE-400 (EN-GJS-400) | O | O | O | O | O | O | O | O |
| | Steel | O | O | O | O | O | O | O | O |
| 1st Auxiliary terminal box | | S | S | S | S | S | S | S | S |
| 2nd Auxiliary terminal box | | O | O | O | O | O | O | O | O |
| 3rd Auxiliary terminal box | | O | O | O | O | O | O | O | O |
| Bearing probes terminal boxes | | O | O | O | O | O | O | O | O |
| External and internal grounding | | S | S | S | S | S | S | S | S |
| Cable glands | | | | | | | | | |
| Plastic cable gland | | NA | NA | NA | NA | NA | NA | NA | NA |
| Brass cable gland | | O | O | O | O | O | O | O | O |
| Stainless steel cable gland | | O | O | O | O | O | O | O | O |
| Flange | | | | | | | | | |
| Flange FF | | O | O | O | O | O | O | O | O |
| Flange FF (Superior) | | OR | OR | OR | OR | OR | OR | OR | OR |
| Flange FF (Inferior) | | OR | OR | OR | OR | OR | OR | OR | OR |
| Double flange FF (DE and NDE) | | OR | OR | OR | OR | OR | OR | OR | OR |
| Flange C | | OR | OR | NA | NA | NA | NA | NA | NA |
| Fan | | | | | | | | | |
| Cast iron | | S | S | S | S | S | O | O | O |
| Aluminium | | O ⁽⁴⁾ | O ⁽⁴⁾ | O ⁽⁴⁾ | O ⁽⁴⁾ | O ⁽⁴⁾ | O ⁽⁴⁾ | O ⁽⁴⁾ | O ⁽⁴⁾ |
| Steel | | O | O | O | O | O | O ⁽³⁾⁽⁵⁾ | O ⁽³⁾⁽⁵⁾ | O ⁽³⁾⁽⁵⁾ |
| Bearing | | | | | | | | | |
| Ball bearing (D.E) | 2P | S | S | S | S | S | S | S ⁽⁶⁾ | OR |
| | 4 - 8P | S | S | S | S | S | S | S | S ⁽⁷⁾ |
| Roller bearing in D.E (for radial external thrusts) | 2P | NA | NA | NA | NA | NA | NA | NA | NA |
| | 4 - 8P | O | O | O | O | O | O | O | NA |
| Ball bearing (N.D.E) | 2P | S | S | S | S | S | O | NA | NA |
| | 4 - 8P | S | S | S | S | S | S | S | NA |
| Angular contact for vertical motors | 2P | O | O | S | S | S | NA | NA | NA |
| | 4 - 8P | O | O | S | S | S | S | S | S |
| Insulated D.E. bearing | | O | O | O | O | O | O | O | O |
| Insulated N.D.E. bearing | | O | O | O | O | O | O | O | O |
| Bearing cap | | | | | | | | | |
| With bearing cap | | S | S | S | S | S | S | S | S |
| Bearing sealing | | | | | | | | | |
| IP56 - Oil seal | 2P | O | O | O | NA | NA | NA | NA | NA |
| | 4 - 8P | O | O | O | O | O | O | O | O |
| IP56 - W3Seal | | O | O | O | O | O | O | O | O |
| IP65 - Double Lip Oil Seal | | O | O | O | NA | NA | NA | NA | NA |
| IP65 - Labyrinth | | O ⁽⁸⁾ | O ⁽⁸⁾ | O ⁽⁸⁾ | O ⁽⁸⁾ | O ⁽⁸⁾ | O ⁽⁸⁾ | O ⁽⁸⁾ | O ⁽⁸⁾ |
| IP66 - W3Seal | | O ⁽⁹⁾ | O ⁽⁹⁾ | O ⁽⁹⁾ | O ⁽⁹⁾ | O ⁽⁹⁾ | O ⁽⁹⁾ | O ⁽⁹⁾ | O ⁽⁹⁾ |
| V-ring, WSeal or W3Seal with | | | | | | | | | |
| Nitrilic rubber | | S | S | S | S | S | S | S | S |
| Silicone rubber | | O | O | O | O | O | O | O | O |

| Line | | W22Xd | | | | | | | |
|--|----------------|-------|--------|--------|--------|------|--------|--------|--------|
| Frame | | 315L | 355M/L | 355A/B | 400L/J | 400G | 450K/H | 500K/H | 560H/G |
| PTFE | | O | O | O | O | O | O | O | O |
| Viton | | O | O | O | O | O | O | O | O |
| Oil seal with | | | | | | | | | |
| Nitrilic rubber | | S | S | S | S | S | S | S | S |
| PTFE | | O | O | O | O | O | O | O | O |
| Silicone rubber | | O | O | O | O | O | O | O | O |
| Viton | | O | O | O | O | O | O | O | O |
| Stainless steel spring | | O | O | O | O | O | O | O | O |
| Other sealing | | | | | | | | | |
| Joints sealing and anti-corrosion protection | Polyrex EM | S | S | S | S | S | S | S | S |
| | Lumomoly PT/04 | O | O | O | O | O | O | O | O |
| | Molykote 33 | O | O | O | O | O | O | O | O |
| Shaft | | | | | | | | | |
| AISI 1045 / C 45 E | | NA | NA | NA | NA | NA | NA | NA | NA |
| AISI 4140 / 42CrMo4 | | S | S | S | S | S | S | S | S |
| AISI 4337 / 34CrNiMo6 | | O | O | O | O | O | O | O | O |
| AISI 1024 / S355J2G3 | | O | O | O | O | O | O | O | O |
| AISI 3415 / 15NiCr13 | | O | O | O | O | O | O | O | O |
| AISI 4340 / 30CrNiMo8 | | O | O | O | O | O | O | O | O |
| AISI 6150H / 50CrV4 | | O | O | O | O | O | O | O | O |
| AISI 304 (stainless steel) / X 5 CrNi 18 10 | | O | O | O | O | O | O | O | O |
| AISI 316 (stainless steel) / X 5 CrNiMo 17 12 2 | | O | O | O | O | O | O | O | O |
| AISI 420 (stainless steel) / X 20 Cr 13 | | O | O | O | O | O | O | O | O |
| Locking shaft device (standard for roller and angular contact bearing motors) | | O | O | O | O | O | O | O | O |
| Second shaft end | | O | O | O | O | O | O | O | O |
| Tapped center hole | | S | S | S | S | S | S | S | S |
| Painting plan | | | | | | | | | |
| <p>202P</p> <p>Primer: One coat with 20 to 30 µm of alkyd oxide red</p> <p>Intermediate: One coat with 80 to 95 µm of isocyanate epoxy paint</p> <p>Finishing: One coat with 65 to 75 µm of polyurethane paint N2677</p> <p>Recommended for food processing industries.</p> | | S | S | S | S | S | S | S | S |
| <p>211E</p> <p>Primer: One coat with 100 to 140 µm of epoxy paint N2630.</p> <p>Finishing: One coat with 100 to 140 µm of epoxy paint N2628.</p> <p>Recommended for motors supplied to Petrobras and its suppliers, to be used in refineries such as petrochemical industries that follow Petrobras specifications.</p> | | O | O | O | O | O | O | O | O |
| <p>211P</p> <p>Primer: One coat with 100 to 140 µm of epoxy paint N2630.</p> <p>Finishing: One coat with 70 to 100 µm of PU paint N2677.</p> <p>Recommended for motors supplied to Petrobras and its suppliers, to be used in refineries such as petrochemical industries that follow Petrobras specifications.</p> | | O | O | O | O | O | O | O | O |
| <p>212E</p> <p>Primer: One coat with 70 to 100 µm of epoxy paint N1277</p> <p>Intermediate: One coat with 100 to 140 µm of epoxy paint N2630</p> <p>Finishing: One coat with 100 to 140 µm of epoxy paint N2628</p> <p>Recommended for applications in pulp and paper, mining, chemical and petrochemical industries</p> | | O | O | O | O | O | O | O | O |
| <p>212P</p> <p>Primer: One coat with 70 to 100 µm of epoxy paint N1277</p> <p>Intermediate: One coat with 100 to 140 µm of epoxy paint N2630</p> <p>Finishing: One coat with 70 to 100 µm of PU paint N2677</p> <p>Recommended for applications in pulp and paper, mining, chemical and petrochemical industries</p> | | O | O | O | O | O | O | O | O |

| Line | W22Xd | | | | | | | | |
|---|--------|--------|--------|--------|------|--------|--------|--------|----|
| | 315L | 355M/L | 355A/B | 400L/J | 400G | 450K/H | 500K/H | 560H/G | |
| 213E Primer: One coat with 75 to 90 µm of Silicate Ethyl paint N1661 Intermediate: One coat with 35 to 50 µm of epoxy paint N1202 Finishing: One coat with 240 to 340 µm of epoxy paint N2628 Recommended for off-shore oil platform. | O | O | O | O | O | O | O | O | |
| Lubrication | | | | | | | | | |
| Esso Mobil Polyrex EM | S | S | S | S | S | S | S | S | |
| Shell Aeroshell 7 | O | O | O | O | O | O | O | O | |
| Shell Aeroshell 22 | O | O | O | O | O | O | O | O | |
| Kluberplex BEM 41-132 | O | O | O | O | O | O | O | O | |
| Shell Albida RL2 | O | O | O | O | O | O | O | O | |
| Grease nipple | | | | | | | | | |
| Carbon steel grease nipple | S | S | S | S | S | S | S | S | |
| Stainless steel grease nipple | O | O | O | O | O | O | O | O | |
| Tecalemit nipple | O | O | O | O | O | O | O | O | |
| Balance | | | | | | | | | |
| Balance with half key | S | S | S | S | S | S | S | S | |
| Balance with full key | O | O | O | O | O | O | O | O | |
| Vibration | | | | | | | | | |
| Grade A | S | S | S | S | S | S | S | S | |
| Grade B | O | O | O | O | O | O | O | O | |
| Vibration monitoring | | | | | | | | | |
| Provision for SPM (1 x M8 x 1,25 on D.E. and N.D.E. endshield at 12 o'clock reading) | S | S | S | S | S | S | S | S | |
| SPM nipples | O | O | O | O | O | O | O | O | |
| Accelerometers | O | O | O | O | O | O | O | O | |
| Key-Phasor | O | O | O | O | O | O | O | O | |
| Vibration Switches | O | O | O | O | O | O | O | O | |
| Drain | | | | | | | | | |
| Certified drain valve in steel (frame mounting) | O | O | O | O | O | O | O | O | |
| Certified drain valve in stainless steel (frame mounting) | O | O | O | O | O | O | O | O | |
| Certified drain valve in steel (terminal boxes mounting) | O | O | O | O | O | O | O | O | |
| Certified drain valve in stainless steel (terminal boxes mounting) | O | O | O | O | O | O | O | O | |
| Other mechanical options | | | | | | | | | |
| Drip cover (standard for vertical shaft down applications) | O | O | O | O | O | O | O | O | |
| Sunshade | O | O | O | O | O | O | O | O | |
| Slinger (standard for vertical shaft up applications) | O | O | O | O | O | O | O | O | |
| Stainless steel hardware (bolts A2-70/A4-70/A2-80/A4-80) | O | O | O | O | O | O | O | O | |
| Grease outlet through the endshield | O | O | O | O | O | O | O | O | |
| Grease removal device | O | O | O | O | O | O | O | O | |
| Motor without fan (AOM) - IC418 | OR | OR | OR | OR | OR | OR | OR | OR | |
| Flying leads | O | O | O | O | O | O | O | O | |
| Electrical options | | | | | | | | | |
| Surface Temperature (Ex d(e) IIB/IIC Gb) | | | | | | | | | |
| T4 (135°C) | S | S | S | S | S | S | S | S | |
| T5 (100°C) | OR | OR | OR | OR | OR | OR | OR | OR | |
| Frequency | | | | | | | | | |
| 60Hz (Bearings application) | 2P | O | O | O | O | O | O | NA | NA |
| | 4 - 8P | O | O | O | O | O | O | O | O |
| 60Hz (Sleeve bearings application) Only for Ex d(e) IIB T4 Gb / Ex d(e) I Mb motors | 2P | O | O | O | O | NA | O | O | O |
| | 4 - 8P | O | O | O | O | O | O | O | O |

| Line | | W22Xd | | | | | | | | |
|---|-------------|--------|--------|--------|--------|------|--------|--------|--------|----|
| Frame | | 315L | 355M/L | 355A/B | 400L/J | 400G | 450K/H | 500K/H | 560H/G | |
| VSD application (mandatory the use of winding thermal probes) ⁽¹⁰⁾ | | | | | | | | | | |
| Voltage | Up to 4160V | O | O | O | O | O | O | O | O | |
| | Up to 6600V | NA | NA | NA | O | O | O | O | O | |
| Frequency (Bearings application) | Up to 50Hz | 2P | O | O | O | O | O | O | O | NA |
| | | 4 - 8P | O | O | O | O | O | O | O | O |
| | Up to 60Hz | 2P | O | O | O | O | O | O | NA | NA |
| | | 4 - 8P | O | O | O | O | O | O | O | O |
| | Up to 63Hz | 2P | O | O | O | NA | NA | NA | NA | NA |
| | | 4P | O | O | O | O | O | O | NA | NA |
| | | 6 - 8P | O | O | O | O | O | O | O | O |
| | Up to 65Hz | 2P | O | NA | NA | NA | NA | NA | NA | NA |
| | | 4P | O | O | O | O | O | O | NA | NA |
| | | 6 - 8P | O | O | O | O | O | O | O | O |
| | Up to 70Hz | 2P | O | NA | NA | NA | NA | NA | NA | NA |
| | | 4P | O | O | O | O | O | NA | NA | NA |
| | | 6 - 8P | O | O | O | O | O | O | O | O |
| | Up to 75Hz | 2P | NA | NA | NA | NA | NA | NA | NA | NA |
| | | 4P | O | O | O | NA | NA | NA | NA | NA |
| | | 6 - 8P | O | O | O | O | O | O | O | O |
| | Up to 90Hz | 2P | NA | NA | NA | NA | NA | NA | NA | NA |
| | | 4P | O | NA | NA | NA | NA | NA | NA | NA |
| | | 6P | O | O | O | O | O | O | NA | NA |
| | | 8P | O | O | O | O | O | O | O | O |
| Up to 100Hz | 2P | NA | NA | NA | NA | NA | NA | NA | NA | |
| | 4P | NA | NA | NA | NA | NA | NA | NA | NA | |
| | 6P | O | O | O | O | O | O | NA | NA | |
| | 8P | O | O | O | O | O | O | O | O | |
| Frequency (Sleeve bearings application) | Up to 50Hz | 2P | O | O | O | O | NA | O | O | OR |
| | | 4 - 8P | O | O | O | O | O | O | O | O |
| | Up to 60Hz | 2P | O | O | O | O | NA | OR | OR | OR |
| | | 4 - 8P | O | O | O | O | O | O | O | O |
| | Above 60Hz | 2P | OR | OR | OR | OR | OR | OR | OR | OR |
| 4 - 8P | | OR | OR | OR | OR | OR | OR | OR | OR | |
| Winding thermal protection | | | | | | | | | | |
| PTC tripping | | O | O | O | O | O | O | O | O | |
| Pt100 three wires, two per phase | | S | S | S | S | S | S | S | S | |
| Pt100 two or four wires, one or two per phase | | O | O | O | O | O | O | O | O | |
| Pt1000 two, three or four wires, one or two per phase | | O | O | O | O | O | O | O | O | |
| CU-10 | | O | O | O | O | O | O | O | O | |
| KTY 84 | | O | O | O | O | O | O | O | O | |
| PTC (alarm / trip) | | O | O | O | O | O | O | O | O | |
| Thermostat (NC or NO) | | O | O | O | O | O | O | O | O | |
| Thermocouple (all types) | | O | O | O | O | O | O | O | O | |
| Surge arresters (connected in thermal probes) | | O | O | O | O | O | O | O | O | |
| Temperature transmitter (4-20mA) in auxiliary terminal box | | O | O | O | O | O | O | O | O | |
| Bearing thermal protection | | | | | | | | | | |
| Pt100 three wires, one per bearing | | S | S | S | S | S | S | S | S | |
| Pt100 two or four wires, one or two per bearing | | O | O | O | O | O | O | O | O | |
| Pt1000 two, three or four wires, one or two per bearing | | O | O | O | O | O | O | O | O | |
| CU-10 | | O | O | O | O | O | O | O | O | |
| Ni-120 | | O | O | O | O | O | O | O | O | |
| PTC (alarm / trip) | | O | O | O | O | O | O | O | O | |

| Line | | W22Xd | | | | | | | |
|---|--|-------|--------|--------|--------|------|--------|--------|--------|
| Frame | | 315L | 355M/L | 355A/B | 400L/J | 400G | 450K/H | 500K/H | 560H/G |
| Thermostat (NC or NO) | | O | O | O | O | O | O | O | O |
| Thermocouple (all types) | | O | O | O | O | O | O | O | O |
| Thermometers | | O | O | O | O | O | O | O | O |
| Temperature transmitter (4-20mA) in auxiliary terminal box | | O | O | O | O | O | O | O | O |
| Space heaters | | | | | | | | | |
| Voltage | 110-127 V | O | O | O | O | O | O | O | O |
| | 230 V | S | S | S | S | S | S | S | S |
| | 220-240 V | O | O | O | O | O | O | O | O |
| | 110-127 / 220-240 V | O | O | O | O | O | O | O | O |
| | 400 V | O | O | O | O | O | O | O | O |
| | 380-480 V | O | O | O | O | O | O | O | O |
| Direction of rotation | | | | | | | | | |
| Both | 2P | S | S | S | S | S | O | O | OR |
| | 4 - 8P | S | S | S | S | S | S | S | S |
| Clockwise rotation direction (looking at D.E. side) | 2P | O | O | O | O | O | S | S | OR |
| | 4 - 8P | O | O | O | O | O | O | O | O |
| Counter clockwise rotation direction (looking at D.E. side) | 2P | O | O | O | O | O | O | O | OR |
| | 4 - 8P | O | O | O | O | O | O | O | O |
| Nameplate with indication of rotation direction | | S | S | S | S | S | S | S | S |
| Service factor | | | | | | | | | |
| Service factor 1.00 | | S | S | S | S | S | S | S | S |
| Other service factor | | OR | OR | OR | OR | OR | OR | OR | OR |
| Insulation class | | | | | | | | | |
| F | | S | S | S | S | S | S | S | S |
| H | | O | O | O | O | O | O | O | O |
| Winding protection and monitoring | | | | | | | | | |
| Surge arresters (only for Ex d terminal boxes) | | O | O | O | O | O | O | O | O |
| Surge capacitors (only for Ex d terminal boxes) | | O | O | O | O | O | O | O | O |
| Current transformers (differential protection or measurement) (only for Ex d terminal boxes) | | O | O | O | O | O | O | O | O |
| Partial discharge sensors (only for Ex d terminal boxes) | | O | O | O | O | O | O | O | O |
| Forced ventilation kit | | | | | | | | | |
| Forced ventilation kit with encoder provision (to be informed auxiliary motor voltage - standard 400V) | Ex d(e) IIB/IIC T4 Gb Ex tb IIIC T125°C Db IP6X Ex d(e) I Mb | O | O | O | O | O | O | O | O |
| | Ex d(e) IIB/IIC T4 Gb Ex tb IIIC T125°C Db IP6X Ex d(e) I Mb | O | O | O | O | O | O | O | O |
| Other electrical optionals | | | | | | | | | |
| Encoder or tacho | | O | O | O | O | O | O | O | O |
| D.E. endshield internal grounding ring | | O | O | O | O | O | O | O | O |
| N.D.E. endshield grounding ring | | O | O | O | O | O | O | O | O |

Notes:

- (1) Requires additional support adaptor
 - (2) Standard for MV motors with line current higher than 630A (WTBX L main terminal box)
 - (3) Standard for Ex d(e) I 2 pole motors
 - (4) Not available for Ex d(e) I motors. Standard for Ex d(e) IIB/IIC and Ex tb IIIC in 2 poles, frames 450K/H and above.
 - (5) Standard for motors 4, 6 and 8 poles
 - (6) Standard bearing arrangement: D.E. - NU220 + 6020 / N.D.E. - NU220
 - (7) Standard bearing arrangement: D.E. - NU328 + 6328 / N.D.E. - NU328
 - (8) Standard for Ex d(e) IIB/IIC 2 poles in frames 450K/H and above and in all motors Ex tb IIIC
 - (9) Standard for Ex d(e) I motors
 - (10) Check also Section 4.4 - Variable Speed Drive
- S - Standard
O - Optional
NA - Not Applicable
OR - On Request

5.3. Standard Features - Tube-Cooled Motors

| Line | | W22Xd..T | | | | | | | | |
|----------------------------------|--------------------------------|---|---|---|------------|-----------------------|------------|------------|------------|------------|
| Frame | | 560J/H | 560H/G | 630K/J | 630J/H | 710K/J ⁽¹⁾ | 710J/H | 710H/G | | |
| General features | | | | | | | | | | |
| Nameplate markings | | ATEX | | | | | | | | |
| Certification marking | | Ex d(e) IIB T4 Gb / Ex d(e) IIC T4 Gb / Ex d(e) I Mb / Ex tb IIIC T125°C Db IP6X (associated with IIB or IIC) | | | | | | | | |
| Ambient temperature | | -20°C up to +40°C | | | | | | | | |
| Mechanical features | | | | | | | | | | |
| Mounting | | B3L | | | | | | | | |
| Frame | Material | Steel S 355 J 2 G 3 (EURONORM) | | | | | | | | |
| Degree of protection | | IP55 - Ex d(e) IIB/IIC T4 Gb IP65 - Ex tb IIIC T125°C Db IP6X IP66 - Ex d(e) I Mb | | | | | | | | |
| Grounding | | Double grounding in the frame + Three grounding in the terminal box (two internal and one external) | | | | | | | | |
| Cooling method | | Air-air integrated heat exchanger - IC511 | | | | | | | | |
| Fan | Internal | Material | 2 - 8P | | Steel | | | | | |
| | External | | 2 - 8P | | Steel | | | | | |
| Fan cover | | Material | | Steel | | | | | | |
| Endshields | | Material | | Steel S 355 J 2 G 3 (EURONORM) | | | | | | |
| Bearings | Clearance D.E | | C3 | | | | | | | |
| | Clearance N.D.E | | C3 | | | | | | | |
| | Locating bearing configuration | 2P | | DE bearing locked with inner and outer bearing caps and fitted with pre-load springs in the NDE bearing Ball and roller bearings arrangement: DE and NDE bearings locked with inner and outer bearing caps | | | | | | |
| | | 4 - 8P | | | | | | | | |
| | Drive end | 2P | | NU220+6020 | NU220+6020 | NU220+6020 | NU220+6020 | NU220+6020 | NA | NA |
| | | 4 - 8P | | 6330 | 6330 | 6332 | 6332 | NA | NU234+6034 | NU238+6038 |
| Non drive end | 2P | | NU220 | NU220 | NU220 | NU220 | NU220 | NA | NA | |
| | 4 - 8P | | 6330 | 6330 | 6332 | 6332 | NA | NU326 | NU326 | |
| Bearing seal | | 2 - 8P | | Labyrinth Seal - Ex d(e) IIB/IIC T4 Gb / Ex tb IIIC T125°C Db IP6X W3Seal - Ex d(e) I Mb | | | | | | |
| Lubrication | Type of grease | | Polyrex EM (Esso Mobil) | | | | | | | |
| | Grease fitting | | With grease fittings in DE and NDE bearings | | | | | | | |
| Sleeve Bearings ⁽²⁾ | Axial float | | 6mm (±3mm) | | | | | | | |
| | Locating bearing configuration | | Located DE bearing | | | | | | | |
| | 2P | | 9 - 90 | | 11 - 100 | | 11 - 110 | | NA | NA |
| | 4 - 8P | | 11 - 125 | | 14 - 140 | | NA | | 14 - 160 | |
| Main cables connection | MV | | I ≤ 315A: 3 x M12 conductor bushings (plus conductor clamps for Ex e terminal boxes execution) - WTBX M terminal box 315A < I ≤ 400A: 3 x M16 conductor bushings (plus conductor clamps for Ex e terminal boxes execution) - WTBX M terminal box 400A < I ≤ 630A: 3 x M20 conductor bushings (plus conductor clamps for Ex e terminal boxes execution) - WTBX M terminal box 630A < I ≤ 800A: 6 x M16 conductor bushings (plus conductor clamps for Ex e terminal boxes execution) - WTBX L terminal box 800A < I ≤ 1260A: 6 x M20 conductor bushings (plus conductor clamps for Ex e terminal boxes execution) - WTBX L terminal box | | | | | | | |
| | HV | | I ≤ 400A: 3 x M16 conductor bushings (plus conductor clamps for Ex e terminal boxes execution) | | | | | | | |
| Terminal box | | Material | | Cast iron FC-200 (EN-GJL-200) | | | | | | |
| Auxiliary terminal box | | With auxiliary terminal box for MV and HV (Cast iron FC-200 (EN-GJL-200)) | | | | | | | | |
| Leads inlet | Main terminal box | MV | | I ≤ 315A: 1 x M63 x 1,5 315A < I ≤ 630A: 3 x M63 x 1,5 630A < I ≤ 1260A: 6 x M63 x 1,5 | | | | | | |
| | | HV | | I ≤ 200A: 1 x M63 x 1,5 200 < I ≤ 400A: 3 x M50 x 1,5 | | | | | | |
| | Auxiliary terminal box | MV | | 3 x M20 x 1,5 | | | | | | |
| | | HV | | 3 x M20 x 1,5 | | | | | | |
| | Plug | | Main terminal box: 1 x plastic plug (other entrances with nickel plated brass certified plugs) Auxiliary terminal box: 3 x nickel plated brass certified plugs | | | | | | | |
| Joint seal | | Without (only machined surfaces) | | | | | | | | |
| Joints anti-corrosion protection | | Polyrex EM (Esso Mobil) | | | | | | | | |
| Bolts class | Enclosure parts | | 12.9 - Ex d(e) IIB/IIC T4 Gb / Ex tb IIIC T125°C Db IP6X A4-80 - Ex d(e) I Mb | | | | | | | |
| | Other parts | | 8.8 - Ex d(e) IIB/IIC T4 Gb / Ex tb IIIC T125°C Db IP6X A4-80 - Ex d(e) I Mb | | | | | | | |



| Line | | W22Xd..T | | | | | | | |
|---------------------------------|----------------------|---|------------------------|--------|--------|-----------------------|--------|--------|--------|
| Frame | | 560J/H | 560H/G | 630K/J | 630J/H | 710K/J ⁽¹⁾ | 710J/H | 710H/G | |
| Shaft (& keys) | Material | | AISI 4140 or AISI 1524 | | | | | | |
| | Threaded hole | 2P | DS M24 | DS M24 | DS M24 | DS M24 | DS M24 | NA | NA |
| | | 4 - 8P | DS M30 | DS M30 | DS M30 | DS M30 | NA | DS M30 | DS M36 |
| Vibration | | Grade A | | | | | | | |
| Provision for vibration sensors | | With (1 x M8 on D.E. and N.D.E. endshield) | | | | | | | |
| Balance | | With half key | | | | | | | |
| Nameplate | Material | Stainless steel AISI 304 | | | | | | | |
| Painting | Plan | 202P | | | | | | | |
| | Colour | Ex d(e) IIB/II C T4 Gb: RAL5009 / Ex d(e) I Mb: RAL2003 | | | | | | | |
| Tropical treatment | | Alkyd resin based varnish painting in rotor, windings, frame (internal), endshields (internal), terminal boxes (internal) and bearing caps (internal) | | | | | | | |
| Electrical features | | | | | | | | | |
| Voltage | | MV (up to 6600V) HV (up to 11000V) | | | | | | | |
| Frequency | | 50 Hz | | | | | | | |
| Winding | Copper wire | Bare copper with mica tape insulation | | | | | | | |
| | Insulation materials | Depending on voltage level, a combination of mica tapes, conductive tapes, semi-conductive tapes and polyester shrinking tapes can be used | | | | | | | |
| | Impregnation | VPI | | | | | | | |
| | Stator cables | Copper with silicone insulation and fiber glass braid | | | | | | | |
| | Insulation class | F (DT 80K) | | | | | | | |
| Service factor | | 1.00 | | | | | | | |
| Rotor | | Copper | | | | | | | |
| Thermal protector | Stator winding | Pt100, 2 per phase (3 wires) in the slots, connected in the auxiliary terminal box. | | | | | | | |
| | Bearings | Pt100, 1 per bearing (3 wires), connected in the auxiliary terminal box | | | | | | | |
| Space heaters | Use | Standard, connected in the auxiliary terminal box | | | | | | | |
| | Voltage | 230V | | | | | | | |
| | Power | 800W | 800W | 900W | 900W | 1000W | 1000W | 1000W | |

Notes:

- (1) - Only for 2 pole motors.
- (2) - As optional for Ex d(e) IIB T4 Gb / Ex d(e) I Mb motors. Please always refer to us for sleeve bearing motors.
- S - Standard
- O - Optional
- NA - Not Applicable
- OR - On Request

5.4. Optional Features - Tube-Cooled Motors

| Line | | W22Xd..T | | | | | | |
|--|--|----------|--------|--------|--------|--------|--------|--------|
| Frame | | 560J/H | 560H/G | 630K/J | 630J/H | 710K/J | 710J/H | 710H/G |
| General optionals | | | | | | | | |
| Nameplate markings | ATEX | S | S | S | S | S | S | S |
| | IECEX | O | O | O | O | O | O | O |
| | EAC Ex (Russia, Belarus, Kazakhstan) | O | O | O | O | O | O | O |
| | SITIAS - NEPSI (China) | OR | OR | OR | OR | OR | OR | OR |
| | CSA _{US} (Canada, USA) | OR | OR | OR | OR | OR | OR | OR |
| | Inmetro (Brazil) | OR | OR | OR | OR | OR | OR | OR |
| | CCOE (India) | OR | OR | OR | OR | OR | OR | OR |
| | SONCAP (Nigeria) | OR | OR | OR | OR | OR | OR | OR |
| Ambient temperature | - 20°C up to +40°C | S | S | S | S | S | S | S |
| | - 40°C up to +40°C | O | O | O | O | O | O | O |
| | - 55°C up to +40°C | OR | OR | OR | OR | OR | OR | OR |
| | - 20°C up to +50°C | O | O | O | O | O | O | O |
| | - 20°C up to +60°C | O | O | O | O | O | O | O |
| Mechanical optionals | | | | | | | | |
| Mounting | | | | | | | | |
| B3L / B3R / B35T / B35L / B35R | | O | O | O | O | O | O | O |
| B5T / B5L / B5R | | NA | NA | NA | NA | NA | NA | NA |
| V1 / V15 | 2P | NA | NA | NA | NA | NA | NA | NA |
| | 4 - 8P | O | O | O | O | O | O | O |
| V3 / V5 / V6 / V36 | 2P | NA | NA | NA | NA | NA | NA | NA |
| | 4 - 8P | NA | NA | NA | NA | NA | NA | NA |
| Frame | | | | | | | | |
| Material | Steel | S | S | S | S | S | S | S |
| Endshields | | | | | | | | |
| Material | Steel | S | S | S | S | S | S | S |
| Main terminal box | | | | | | | | |
| Material | FC-200 (EN-GJL-200) | S | S | S | S | S | S | S |
| | FE-400 (EN-GJS-400) | O | O | O | O | O | O | O |
| | Steel | O | O | O | O | O | O | O |
| Gland plate (for main terminal box) | Ex d | O | O | O | O | O | O | O |
| | Ex e | O | O | O | O | O | O | O |
| External and internal grounding | | S | S | S | S | S | S | S |
| Fault rate level terminal box (Ex d) | Up to 6.6kV: 45kA/0,25s | O | O | O | O | O | O | O |
| | Up to 11kV: 45kA 0,25s | O | O | O | O | O | O | O |
| Fault rate level terminal box (Ex e) | Up to 6.6kV: 25kA 0,25s | O | O | O | O | O | O | O |
| | Up to 11kV: 25kA 0,25s | O | O | O | O | O | O | O |
| 2nd main terminal box for neutral connection | | O | O | O | O | O | O | O |
| Oversized terminal box WTBX XL (for main power terminals, neutral point, current transformers, surge arrestors, surge capacitors and partial discharge monitoring) | | O | O | O | O | O | O | O |
| Phase segregated terminal box (Ex e) - Up to 11kV: 44kA 0,25s | | O | O | O | O | O | O | O |
| Phase insulated terminal box (Ex e) - Up to 6.6kV: 26,3kA 0,25s | | O | O | O | O | O | O | O |

| Line | | W22Xd..T | | | | | | |
|--|---------------------|------------------|------------------|------------------|------------------|------------------|------------------|------------------|
| Frame | | 560J/H | 560H/G | 630K/J | 630J/H | 710K/J | 710J/H | 710H/G |
| WTBX L Phase insulated terminal box (Ex e) - Up to 11kV: 50kA/1s | | O | O | O | O | O | O | O |
| WTBX L power terminal box with neutral point (6 terminals) | | O | O | O | O | O | O | O |
| Main cables connection | | | | | | | | |
| MV - Six conductor bushings | | O ⁽¹⁾ | O ⁽¹⁾ | O ⁽¹⁾ | O ⁽¹⁾ | O ⁽¹⁾ | O ⁽¹⁾ | O ⁽¹⁾ |
| HV - Six conductor bushings | | O | O | O | O | O | O | O |
| Auxiliary terminal boxes | | | | | | | | |
| Material | FC-200 (EN-GJL-200) | S | S | S | S | S | S | S |
| | FE-400 (EN-GJS-400) | O | O | O | O | O | O | O |
| | Steel | O | O | O | O | O | O | O |
| 1st Auxiliary terminal box | | S | S | S | S | S | S | S |
| 2nd Auxiliary terminal box | | O | O | O | O | O | O | O |
| 3rd Auxiliary terminal box | | O | O | O | O | O | O | O |
| Bearing probes terminal boxes | | O | O | O | O | O | O | O |
| External and internal grounding | | S | S | S | S | S | S | S |
| Cable glands | | | | | | | | |
| Plastic cable gland | | NA | NA | NA | NA | NA | NA | NA |
| Brass cable gland | | O | O | O | O | O | O | O |
| Stainless steel cable gland | | O | O | O | O | O | O | O |
| Flange | | | | | | | | |
| Flange FF | | O | O | O | O | O | O | O |
| Flange FF (Superior) | | OR | OR | OR | OR | OR | OR | OR |
| Flange FF (Inferior) | | OR | OR | OR | OR | OR | OR | OR |
| Fan | | | | | | | | |
| Cast iron | | NA | NA | NA | NA | NA | NA | NA |
| Aluminium | | NA | NA | NA | NA | NA | NA | NA |
| Steel | | S | S | S | S | S | S | S |
| Bearing | | | | | | | | |
| Ball bearing (D.E) | 2P | S ⁽²⁾ | S ⁽²⁾ | S ⁽²⁾ | S ⁽²⁾ | S ⁽²⁾ | NA | NA |
| | 4 - 8P | S | S | S | S | NA | S ⁽³⁾ | S ⁽³⁾ |
| Roller bearing in D.E (for radial external thrusts) | 2P | NA | NA | NA | NA | NA | NA | NA |
| | 4 - 8P | O | O | O | O | NA | O | O |
| Ball bearing (N.D.E) | 2P | NA | NA | NA | NA | NA | NA | NA |
| | 4 - 8P | S | S | S | S | NA | NA | NA |
| Angular contact for vertical motors | 2P | NA | NA | NA | NA | NA | NA | NA |
| | 4 - 8P | S | S | S | S | NA | S | S |
| Insulated D.E. bearing | | O | O | O | O | O | O | O |
| Insulated N.D.E. bearing | | O | O | O | O | O | O | O |
| Bearing cap | | | | | | | | |
| With bearing cap | | S | S | S | S | S | S | S |
| Bearing sealing | | | | | | | | |
| IP55 / IP65 - Labyrinth | 2 - 8P | S | S | S | S | S | S | S |
| IP56 / IP66 - W3seal | 2 - 8P | O ⁽⁴⁾ | O ⁽⁴⁾ | O ⁽⁴⁾ | O ⁽⁴⁾ | O ⁽⁴⁾ | O ⁽⁴⁾ | O ⁽⁴⁾ |
| IP56 - Oil seal | 4 - 8P | O | O | O | O | O | O | O |
| IP65 - Double lip oil seal | 4 - 8P | O | O | O | O | O | O | O |
| W3seal with | | | | | | | | |
| Nitrilic rubber | | S | S | S | S | S | S | S |
| Silicone rubber | | O | O | O | O | O | O | O |
| PTFE | | O | O | O | O | O | O | O |
| Viton | | O | O | O | O | O | O | O |
| Oil seal with | | | | | | | | |
| Nitrilic rubber | | S | S | S | S | S | S | S |
| PTFE | | O | O | O | O | O | O | O |

| Line | | W22Xd..T | | | | | | |
|--|----------------|------------------|------------------|------------------|------------------|------------------|------------------|------------------|
| Frame | | 560J/H | 560H/G | 630K/J | 630J/H | 710K/J | 710J/H | 710H/G |
| Silicone rubber | | O | O | O | O | O | O | O |
| Viton | | O | O | O | O | O | O | O |
| Stainless steel spring | | O | O | O | O | O | O | O |
| Other sealing | | | | | | | | |
| Joints sealing and anti-corrosion protection | Polyrex EM | S | S | S | S | S | S | S |
| | Lumomoly PT/04 | O | O | O | O | O | O | O |
| | Molykote 33 | O | O | O | O | O | O | O |
| Shaft | | | | | | | | |
| AISI 4140 / 42CrMo4 | | O ⁽⁵⁾ | O ⁽⁵⁾ | O ⁽⁵⁾ | O ⁽⁵⁾ | O ⁽⁵⁾ | O ⁽⁵⁾ | O ⁽⁵⁾ |
| AISI 1024 / S355J2G3 | | S | S | S | S | S | S | S |
| AISI 3415 / 15NiCr13 | | O ⁽⁶⁾ | O ⁽⁶⁾ | O ⁽⁶⁾ | O ⁽⁶⁾ | O ⁽⁶⁾ | O ⁽⁶⁾ | O ⁽⁶⁾ |
| AISI 304 (stainless steel) / X 5 CrNi 18 10 | | O ⁽⁶⁾ | O ⁽⁶⁾ | O ⁽⁶⁾ | O ⁽⁶⁾ | O ⁽⁶⁾ | O ⁽⁶⁾ | O ⁽⁶⁾ |
| AISI 316 (stainless steel) / X 5 CrNiMo 17 12 2 | | O ⁽⁶⁾ | O ⁽⁶⁾ | O ⁽⁶⁾ | O ⁽⁶⁾ | O ⁽⁶⁾ | O ⁽⁶⁾ | O ⁽⁶⁾ |
| AISI 420 (stainless steel) / X 20 Cr 13 | | O ⁽⁶⁾ | O ⁽⁶⁾ | O ⁽⁶⁾ | O ⁽⁶⁾ | O ⁽⁶⁾ | O ⁽⁶⁾ | O ⁽⁶⁾ |
| Locking shaft device (standard for roller and angular contact bearing motors) | | O | O | O | O | O | O | O |
| Second shaft end | | OR | OR | OR | OR | OR | OR | OR |
| Tapped center hole | | S | S | S | S | S | S | S |
| Painting plan | | | | | | | | |
| 202P Primer: One coat with 20 to 30 µm of alkyd oxide red Intermediate: One coat with 80 to 95 µm of isocyanate epoxy paint Finishing: One coat with 65 to 75 µm of polyurethane paint N2677 Recommended for food processing industries. | | S | S | S | S | S | S | S |
| 211E Primer: One coat with 100 to 140 µm of epoxy paint N2630. Finishing: One coat with 100 to 140 µm of epoxy paint N2628. Recommended for motors supplied to Petrobras and its suppliers, to be used in refineries such as petrochemical industries that follow Petrobras specifications. | | O | O | O | O | O | O | O |
| 211P Primer: One coat with 100 to 140 µm of epoxy paint N2630. Finishing: One coat with 70 to 100 µm of PU paint N2677. Recommended for motors supplied to Petrobras and its suppliers, to be used in refineries such as petrochemical industries that follow Petrobras specifications. | | O | O | O | O | O | O | O |
| 212E Primer: One coat with 70 to 100 µm of epoxy paint N1277 Intermediate: One coat with 100 to 140 µm of epoxy paint N2630 Finishing: One coat with 100 to 140 µm of epoxy paint N2628 Recommended for applications in pulp and paper, mining, chemical and petrochemical industries | | O | O | O | O | O | O | O |
| 212P Primer: One coat with 70 to 100 µm of epoxy paint N1277 Intermediate: One coat with 100 to 140 µm of epoxy paint N2630 Finishing: One coat with 70 to 100 µm of PU paint N2677 Recommended for applications in pulp and paper, mining, chemical and petrochemical industries | | O | O | O | O | O | O | O |
| 213E Primer: One coat with 75 to 90 µm of Silicate Ethyl paint N1661 Intermediate: One coat with 35 to 50 µm of epoxy paint N1202 Finishing: One coat with 240 to 340 µm of epoxy paint N2628 Recommended for off-shore oil platform. | | O | O | O | O | O | O | O |
| Lubrication | | | | | | | | |
| Esso Mobil Polyrex EM | | S | S | S | S | S | S | S |
| Shell Aeroshell 7 | | O | O | O | O | O | O | O |
| Shell Aeroshell 22 | | O | O | O | O | O | O | O |
| Kluberplex BEM 41-132 | | O | O | O | O | O | O | O |

| Line | | W22Xd..T | | | | | | |
|--|-------------|----------|--------|--------|--------|--------|--------|--------|
| Frame | | 560J/H | 560H/G | 630K/J | 630J/H | 710K/J | 710J/H | 710H/G |
| Shell Albida RL2 | | O | O | O | O | O | O | O |
| Grease nipple | | | | | | | | |
| Carbon steel grease nipple | | S | S | S | S | S | S | S |
| Stainless steel grease nipple | | O | O | O | O | O | O | O |
| Tecalemit nipple | | O | O | O | O | O | O | O |
| Balance | | | | | | | | |
| Balance with half key | | S | S | S | S | S | S | S |
| Balance with full key | | O | O | O | O | O | O | O |
| Vibration | | | | | | | | |
| Grade A | | S | S | S | S | S | S | S |
| Grade B | | O | O | O | O | O | O | O |
| Vibration monitoring | | | | | | | | |
| Provision for SPM (1 x hole M8 on D.E. and N.D.E. shield for vertical reading) | | S | S | S | S | S | S | S |
| Accelerometers | | O | O | O | O | O | O | O |
| Key-Phasor | | O | O | O | O | O | O | O |
| Drain | | | | | | | | |
| Certified drain valve in steel (frame mounting) | | O | O | O | O | O | O | O |
| Certified drain valve in stainless steel (frame mounting) | | O | O | O | O | O | O | O |
| Certified drain valve in steel (terminal boxes mounting) | | O | O | O | O | O | O | O |
| Certified drain valve in stainless steel (terminal boxes mounting) | | O | O | O | O | O | O | O |
| Other mechanical options | | | | | | | | |
| Sunshade | | O | O | O | O | O | O | O |
| Slinger (recommended for vertical shaft up applications) | | NA | NA | NA | NA | NA | NA | NA |
| Stainless steel hardware (bolts A2-70/A4-70/A2-80/A4-80) | | O | O | O | O | O | O | O |
| Grease outlet through the endshield | | O | O | O | O | O | O | O |
| Flying leads | | O | O | O | O | O | O | O |
| Electrical options | | | | | | | | |
| Surface Temperature (Ex d(e) IIB/IIC Gb) | | | | | | | | |
| T4 (135°C) | | S | S | S | S | S | S | S |
| T5 (100°C) | | O | O | O | O | O | O | O |
| Frequency | | | | | | | | |
| 60Hz (Bearings application) | 2P | NA | NA | NA | NA | NA | NA | NA |
| | 4 - 8P | O | O | O | O | O | O | O |
| 60Hz (Sleeve bearings application) Only for Ex d(e) IIB T4 Gb / Ex d(e) I Mb motors | 2P | O | O | O | O | O | O | O |
| | 4 - 8P | O | O | O | O | O | O | O |
| VSD application (mandatory the use of winding thermal probes) ⁽⁷⁾ | | | | | | | | |
| Voltage | Up to 4160V | O | O | O | O | O | O | O |
| | Up to 6600V | O | O | O | O | O | O | O |
| Frequency (Bearings application) | Up to 50Hz | 2P | O | O | O | O | O | O |
| | | 4 - 8P | O | O | O | O | O | O |
| | Up to 60Hz | 2P | NA | NA | NA | NA | NA | NA |
| | | 4 - 8P | O | O | O | O | O | O |
| | Up to 63Hz | 2 - 4P | NA | NA | NA | NA | NA | NA |
| | | 6 - 8P | O | O | O | O | O | O |
| | Up to 65Hz | 2 - 4P | NA | NA | NA | NA | NA | NA |
| | | 6 - 8P | O | O | O | O | O | O |
| | Up to 70Hz | 2 - 4P | NA | NA | NA | NA | NA | NA |
| | | 6 - 8P | O | O | O | O | O | O |
| | Up to 75Hz | 2 - 4P | NA | NA | NA | NA | NA | NA |
| | | 6 - 8P | O | O | O | O | O | O |

| Line | | | W22Xd..T | | | | | | |
|--|---------------------|--------|----------|--------|--------|--------|--------|--------|--------|
| Frame | | | 560J/H | 560H/G | 630K/J | 630J/H | 710K/J | 710J/H | 710H/G |
| Frequency (Bearings application) | Up to 90Hz | 2 - 4P | NA | NA | NA | NA | NA | NA | NA |
| | | 6 - 8P | O | O | O | O | O | O | O |
| | Up to 100Hz | 2 - 6P | NA | NA | NA | NA | NA | NA | NA |
| | | 8P | O | O | O | O | O | O | O |
| Frequency (sleeve bearings application) | Up to 50Hz | 2P | OR | OR | OR | OR | OR | OR | OR |
| | | 4 - 8P | O | O | O | O | O | O | O |
| | Up to 60Hz | 2P | OR | OR | OR | OR | OR | OR | OR |
| | | 4 - 8P | O | O | O | O | O | O | O |
| | Above 60Hz | 2P | OR | OR | OR | OR | OR | OR | OR |
| | | 4 - 8P | OR | OR | OR | OR | OR | OR | OR |
| Winding thermal protection | | | | | | | | | |
| PTC tripping | | | O | O | O | O | O | O | O |
| Pt100 three wires, two per phase | | | S | S | S | S | S | S | S |
| Pt100 two or four wires, one or two per phase | | | O | O | O | O | O | O | O |
| Pt1000 two, three or four wires, one or two per phase | | | O | O | O | O | O | O | O |
| CU-10 | | | O | O | O | O | O | O | O |
| KTY 84 | | | O | O | O | O | O | O | O |
| PTC (alarm / trip) | | | O | O | O | O | O | O | O |
| Thermostat (NC or NO) | | | O | O | O | O | O | O | O |
| Thermocouple (all types) | | | O | O | O | O | O | O | O |
| Surge arresters (connected in thermal probes) | | | O | O | O | O | O | O | O |
| Temperature transmitter (4-20mA) in auxiliary terminal box | | | O | O | O | O | O | O | O |
| Bearing thermal protection | | | | | | | | | |
| Pt100 three wires, one per bearing | | | S | S | S | S | S | S | S |
| Pt100 two or four wires, one or two per bearing | | | O | O | O | O | O | O | O |
| Pt1000 two, three or four wires, one or two per bearing | | | O | O | O | O | O | O | O |
| CU-10 | | | O | O | O | O | O | O | O |
| Ni-120 | | | O | O | O | O | O | O | O |
| PTC (alarm / trip) | | | O | O | O | O | O | O | O |
| Thermostat (NC or NO) | | | O | O | O | O | O | O | O |
| Thermocouple (all types) | | | O | O | O | O | O | O | O |
| Thermometers | | | O | O | O | O | O | O | O |
| Temperature transmitter (4-20mA) in auxiliary terminal box | | | O | O | O | O | O | O | O |
| Space heaters | | | | | | | | | |
| Voltage | 110-127 V | | O | O | O | O | O | O | O |
| | 230 V | | S | S | S | S | S | S | S |
| | 220-240 V | | O | O | O | O | O | O | O |
| | 110-127 / 220-240 V | | O | O | O | O | O | O | O |
| | 400 V | | O | O | O | O | O | O | O |
| | 380-480 V | | O | O | O | O | O | O | O |
| Direction of rotation | | | | | | | | | |
| Both | 2 - 4P | | O | O | O | O | O | O | O |
| | 6 - 8P | | S | S | S | S | S | S | S |
| Clockwise rotation direction | 2 - 4P | | S | S | S | S | S | S | S |
| | 6 - 8P | | O | O | O | O | O | O | O |
| Counter clockwise rotation direction | | | O | O | O | O | O | O | O |
| Nameplate with indication of rotation direction | | | S | S | S | S | S | S | S |
| Service factor | | | | | | | | | |
| Service factor 1.00 | | | S | S | S | S | S | S | S |
| Service factor 1.15 | | | O | O | O | O | O | O | O |
| Insulation class | | | | | | | | | |
| F | | | S | S | S | S | S | S | S |

| Line | | W22Xd..T | | | | | | |
|---|--|----------|--------|--------|--------|--------|--------|--------|
| Frame | | 560J/H | 560H/G | 630K/J | 630J/H | 710K/J | 710J/H | 710H/G |
| H | | ○ | ○ | ○ | ○ | ○ | ○ | ○ |
| Winding protection and monitoring | | | | | | | | |
| Surge arresters (only for Ex d terminal boxes) | | ○ | ○ | ○ | ○ | ○ | ○ | ○ |
| Surge capacitors (only for Ex d terminal boxes) | | ○ | ○ | ○ | ○ | ○ | ○ | ○ |
| Current transformers (differential protection or measurement) (only for Ex d terminal boxes) | | ○ | ○ | ○ | ○ | ○ | ○ | ○ |
| Partial discharge sensors (only for Ex d terminal boxes) | | ○ | ○ | ○ | ○ | ○ | ○ | ○ |
| Forced ventilation kit | | | | | | | | |
| Forced ventilation kit with encoder provision (to be informed auxiliary motor voltage - standard 400V) | Ex d(e) IIB/IIC T4 Gb Ex tb IIIC T125°C Db IP6X Ex d(e) I Mb | ○ | ○ | ○ | ○ | ○ | ○ | ○ |
| Forced ventilation kit without encoder provision (to be informed auxiliary motor voltage - standard 400V) | Ex d(e) IIB/IIC T4 Gb Ex tb IIIC T125°C Db IP6X Ex d(e) I Mb | ○ | ○ | ○ | ○ | ○ | ○ | ○ |
| Other electrical options | | | | | | | | |
| Encoder or tacho | | ○ | ○ | ○ | ○ | ○ | ○ | ○ |
| D.E. endshield grounding ring | | ○ | ○ | ○ | ○ | ○ | ○ | ○ |
| N.D.E. endshield internal grounding ring | | ○ | ○ | ○ | ○ | ○ | ○ | ○ |

Notes:

- (1) Standard for MV motors with line current higher than 630A (WTBX L main terminal box)
- (2) Standard bearing arrangement: D.E. - NU220 + 6020 / N.D.E. - NU220
- (3) Standard bearing arrangement: D.E. - NU234 + 6034 / N.D.E. - NU326
- (4) Standard for Ex d(e) I motors
- (5) Standard in some frame sizes
- (6) Requires case by case analysis
- (7) Check also Section 4.4 - Variable Speed Drive
- S - Standard
- - Optional
- NA - Not Applicable
- OR - On Request

Electrical and Mechanical Data

| | |
|--------------------------------------|------------|
| 6.1. W22Xd Rib-Cooled Series | 97 |
| 6.2. W22Xd Tube-Cooled Series | 133 |

6. Electrical and Mechanical Data

6.1. W22Xd Rib-Cooled Series

- Ex d(e) IIB T4 Gb (Ex tb IIIC T125°C Db IP6X)
- Ex d(e) IIC T4 Gb (Ex tb IIIC T125°C Db IP6X)
- Ex d(e) I Mb

W22Xd rib-cooled motor line is available for Medium and High Voltage with shaft height from 315mm up to 560mm with the following powers:

| W22Xd - Medium Voltage (1100V < U ≤ 6600V) | | W22Xd - High Voltage (6600V < U ≤ 11000V) | |
|---|-------------|--|-------------|
| Powers (kW) | Speed (RPM) | Powers (kW) | Speed (RPM) |
| 90 up to 1250 | 3000 | 355 up to 800 | 3000 |
| 90 up to 1600 | 1500 | 355 up to 1120 | 1500 |
| 90 up to 1250 | 1000 | 280 up to 800 | 1000 |
| 90 up to 1000 | 750 | 250 up to 560 | 750 |

In relation to the different available optional features, W22Xd rib-cooled motors are designated as follows:

- W22XdB: Standard Ex d IIB T4 Gb motor
- W22XdBE: Ex d e IIB T4 Gb motor
- W22XdBD: Ex d IIB T4 Gb and Ex tb IIIC Db IP6X motor
- W22XdBED: Ex d e IIB T4 Gb and Ex tb IIIC Db IP6X motor
- W22XdBS: Ex d IIB T4 Gb motor with sleeve bearings
- W22XdBES: Ex d e IIB T4 Gb motor with sleeve bearings
- W22XdBDS: Ex d IIB T4 Gb and Ex tb IIIC Db IP6X motor with sleeve bearings
- W22XdBEDS: Ex d e IIB T4 Gb and Ex tb IIIC Db IP6X motor with sleeve bearings
- W22XdC: Standard Ex d IIC T4 Gb motor
- W22XdCE: Ex d e IIC T4 Gb motor
- W22XdCD: Ex d IIC T4 Gb and Ex tb IIIC Db IP6X motor
- W22XdCED: Ex d e IIB T4 Gb and Ex tb IIIC Db IP6X motor
- W22XdM: Standard Ex d I Mb motor
- W22XdME: Ex d e I Mb motor
- W22XdMS: Ex d I Mb motor with sleeve bearings
- W22XdMES: Ex d e I Mb motor with sleeve bearings



6.1.1. Medium Voltage - Electrical Data (1100V < U ≤ 6600V)

W22Xd Rib-Cooled Series / Standard - Anti-friction bearings arrangement

| Output | | Frame IEC | T _n (Nm) | I _s /I _n | T _s /T _n | T _{max} /T _n | Inertia J (Kgm²) | Allowable locked rotor time Hot/Cold (s) | Weight (Kg) | Sound Pressure dB(A) | RPM | Y 3000V/50Hz | | | | | | I _n (A) | |
|--|------|------------------|---------------------|--------------------------------|--------------------------------|----------------------------------|------------------|--|-------------|----------------------|-----|------------------|------|------|--------------------|------|------|--------------------|------|
| kW | HP | | | | | | | | | | | % of full load | | | | | | | |
| | | | | | | | | | | | | Efficiency η (%) | | | Power Factor Cos φ | | | | |
| | | 50 | 75 | 100 | 50 | 75 | 100 | | | | | | | | | | | | |
| II Pole - 3000 min⁻¹ | | | | | | | | | | | | | | | | | | | |
| 90 | 120 | W22Xd 315L | 289 | 6,7 | 1,5 | 2,5 | 1,3 | 7 | 15 | 1800 | 80 | 2978 | 91,5 | 93,6 | 94,5 | 0,70 | 0,81 | 0,86 | 21,3 |
| 110 | 150 | W22Xd 315L | 353 | 6,8 | 1,6 | 2,6 | 1,5 | 6 | 12 | 1850 | 80 | 2978 | 93,3 | 94,3 | 94,6 | 0,71 | 0,82 | 0,87 | 25,7 |
| 132 | 180 | W22Xd 315L | 423 | 6,8 | 1,6 | 2,6 | 1,6 | 6 | 12 | 1900 | 80 | 2978 | 93,9 | 94,6 | 94,7 | 0,72 | 0,82 | 0,87 | 30,8 |
| 160 | 215 | W22Xd 355M/L | 512 | 7,5 | 1,4 | 2,9 | 3,3 | 12 | 24 | 2100 | 80 | 2986 | 94,1 | 95,3 | 95,7 | 0,81 | 0,87 | 0,88 | 36,6 |
| 200 | 270 | W22Xd 355M/L | 640 | 7,5 | 1,4 | 2,9 | 3,7 | 10 | 20 | 2200 | 80 | 2986 | 94,5 | 95,5 | 95,9 | 0,81 | 0,86 | 0,88 | 45,6 |
| 250 | 340 | W22Xd 355A/B | 800 | 7,5 | 1,4 | 3,0 | 4,8 | 11 | 22 | 2600 | 80 | 2986 | 94,8 | 95,7 | 96,0 | 0,85 | 0,89 | 0,90 | 55,7 |
| 280 | 380 | W22Xd 355A/B | 896 | 7,5 | 1,4 | 3,0 | 5,1 | 10 | 20 | 2700 | 80 | 2986 | 95,0 | 95,9 | 96,2 | 0,85 | 0,89 | 0,90 | 62,2 |
| 315 | 425 | W22Xd 355A/B | 1007 | 7,5 | 1,5 | 3,0 | 5,4 | 9 | 18 | 2850 | 80 | 2986 | 95,1 | 96,0 | 96,3 | 0,84 | 0,88 | 0,90 | 69,9 |
| 355 | 480 | W22Xd 355A/B | 1135 | 7,5 | 1,5 | 3,1 | 5,8 | 8 | 16 | 3050 | 80 | 2986 | 95,3 | 96,1 | 96,4 | 0,83 | 0,88 | 0,90 | 78,7 |
| 400 | 540 | W22Xd 400L/J | 1279 | 6,5 | 1,5 | 2,6 | 9,9 | 8 | 16 | 4050 | 80 | 2986 | 95,5 | 96,3 | 96,6 | 0,82 | 0,87 | 0,88 | 90,6 |
| 450 | 610 | W22Xd 400L/J | 1439 | 6,5 | 1,5 | 2,6 | 10,2 | 7 | 14 | 4100 | 80 | 2986 | 95,9 | 96,6 | 96,8 | 0,83 | 0,87 | 0,88 | 102 |
| 500 | 675 | W22Xd 400L/J | 1599 | 6,7 | 1,7 | 2,8 | 10,8 | 6 | 12 | 4200 | 80 | 2986 | 95,9 | 96,7 | 97,0 | 0,81 | 0,86 | 0,88 | 113 |
| 560 | 755 | W22Xd 400G | 179 1 | 6,7 | 1,7 | 2,8 | 12,5 | 6 | 12 | 5200 | 80 | 2986 | 96,3 | 96,9 | 97,0 | 0,83 | 0,87 | 0,88 | 126 |
| 630 | 850 | W22Xd 400G (1) | 2012 | 6,1 | 1,0 | 2,8 | 13,5 | 8 | 22 | 5400 | 80 | 2990 | 96,9 | 97,3 | 97,4 | 0,85 | 0,89 | 0,90 | 138 |
| 710 | 960 | W22Xd 450K/H (1) | 2267 | 6,1 | 0,7 | 2,8 | 14,3 | 14 | 36 | 6400 | 80 | 2991 | 96,8 | 97,4 | 97,6 | 0,84 | 0,89 | 0,90 | 156 |
| 800 | 1080 | W22Xd 450K/H (1) | 2554 | 6,1 | 0,7 | 2,8 | 15,2 | 13 | 32 | 6650 | 80 | 2991 | 96,9 | 97,5 | 97,6 | 0,84 | 0,89 | 0,90 | 175 |
| 900 | 1215 | W22Xd 500K/H (1) | 2875 | 5,9 | 0,6 | 2,6 | 21,7 | 14 | 36 | 9000 | 85 | 2990 | 97,0 | 97,6 | 97,7 | 0,85 | 0,90 | 0,91 | 195 |
| 1000 | 1350 | W22Xd 500K/H (1) | 3193 | 6,1 | 0,7 | 2,8 | 23,2 | 10 | 26 | 9200 | 85 | 2991 | 97,2 | 97,7 | 97,8 | 0,85 | 0,90 | 0,91 | 216 |
| 1120 | 1515 | W22Xd 500K/H (1) | 3576 | 6,5 | 0,8 | 3,0 | 24,7 | 8 | 20 | 9650 | 85 | 2991 | 97,2 | 97,7 | 97,9 | 0,85 | 0,90 | 0,91 | 242 |
| 1120 | 1515 | W22Xd 560H/G (1) | On request | | | | | | | | | | | | | | | | |
| 1250 | 1690 | W22Xd 560H/G (1) | On request | | | | | | | | | | | | | | | | |

IV Pole - 1500 min⁻¹

| | | | | | | | | | | | | | | | | | | | |
|------|------|------------------|-------|-----|-----|-----|------|----|----|-------|----|------|------|------|------|------|------|------|------|
| 90 | 120 | W22Xd 315L | 579 | 6,7 | 1,2 | 2,5 | 2,6 | 20 | 40 | 1785 | 76 | 1484 | 93,0 | 94,2 | 94,5 | 0,70 | 0,80 | 0,83 | 22,0 |
| 110 | 150 | W22Xd 315L | 708 | 6,7 | 1,3 | 2,5 | 2,8 | 15 | 32 | 1825 | 76 | 1484 | 93,0 | 94,2 | 94,5 | 0,70 | 0,80 | 0,83 | 26,9 |
| 132 | 180 | W22Xd 315L | 849 | 6,7 | 1,3 | 2,5 | 3,1 | 15 | 32 | 1875 | 76 | 1484 | 93,0 | 94,2 | 94,6 | 0,70 | 0,80 | 0,83 | 32,2 |
| 160 | 215 | W22Xd 355M/L | 1025 | 6,7 | 1,5 | 2,9 | 5,4 | 18 | 39 | 2200 | 76 | 1491 | 94,5 | 95,5 | 95,8 | 0,73 | 0,81 | 0,84 | 38,3 |
| 200 | 270 | W22Xd 355M/L | 1281 | 6,7 | 1,5 | 2,9 | 6,3 | 16 | 34 | 2300 | 76 | 1491 | 95,1 | 95,9 | 96,1 | 0,73 | 0,81 | 0,84 | 47,7 |
| 250 | 340 | W22Xd 355A/B | 1601 | 7,2 | 1,5 | 2,9 | 7,3 | 11 | 23 | 2775 | 76 | 1491 | 95,1 | 95,9 | 96,1 | 0,71 | 0,80 | 0,84 | 59,7 |
| 280 | 380 | W22Xd 355A/B | 1793 | 7,2 | 1,5 | 2,9 | 7,5 | 10 | 21 | 2900 | 76 | 1491 | 95,4 | 96,1 | 96,2 | 0,73 | 0,82 | 0,84 | 66,7 |
| 315 | 425 | W22Xd 355A/B | 2018 | 7,2 | 1,6 | 2,9 | 8,2 | 9 | 19 | 3050 | 76 | 1491 | 95,4 | 96,2 | 96,3 | 0,72 | 0,81 | 0,84 | 74,9 |
| 355 | 480 | W22Xd 355A/B | 2274 | 7,2 | 1,6 | 2,9 | 8,7 | 9 | 19 | 3250 | 76 | 1491 | 95,4 | 96,2 | 96,3 | 0,71 | 0,80 | 0,84 | 84,5 |
| 400 | 540 | W22Xd 400L/J | 2559 | 6,5 | 1,4 | 2,8 | 19,1 | 12 | 28 | 4200 | 80 | 1493 | 95,0 | 96,0 | 96,3 | 0,77 | 0,84 | 0,86 | 93,0 |
| 450 | 610 | W22Xd 400L/J | 2878 | 6,5 | 1,4 | 2,8 | 20,1 | 11 | 25 | 4350 | 80 | 1493 | 95,1 | 96,1 | 96,4 | 0,77 | 0,84 | 0,86 | 104 |
| 500 | 675 | W22Xd 400L/J | 3198 | 6,5 | 1,4 | 2,8 | 21,3 | 10 | 23 | 4550 | 80 | 1493 | 95,4 | 96,3 | 96,6 | 0,77 | 0,84 | 0,86 | 116 |
| 560 | 755 | W22Xd 400G (1) | 3584 | 6,1 | 0,7 | 2,8 | 25,9 | 13 | 26 | 5350 | 80 | 1492 | 96,4 | 96,9 | 97,0 | 0,82 | 0,88 | 0,89 | 125 |
| 630 | 850 | W22Xd 400G (1) | 4033 | 6,0 | 0,7 | 2,8 | 27,1 | 11 | 23 | 5540 | 80 | 1492 | 96,6 | 97,0 | 97,0 | 0,82 | 0,88 | 0,89 | 140 |
| 710 | 960 | W22Xd 400G (1) | 4545 | 6,2 | 0,7 | 2,8 | 27,6 | 9 | 20 | 5600 | 80 | 1492 | 96,6 | 97,0 | 97,0 | 0,82 | 0,88 | 0,89 | 158 |
| 800 | 1080 | W22Xd 450K/H (1) | 5117 | 6,1 | 0,8 | 2,6 | 28,2 | 14 | 28 | 6700 | 80 | 1493 | 96,9 | 97,3 | 97,4 | 0,78 | 0,85 | 0,87 | 182 |
| 900 | 1215 | W22Xd 450K/H (1) | 5757 | 6,1 | 0,8 | 2,5 | 29,7 | 13 | 25 | 7000 | 80 | 1493 | 96,9 | 97,3 | 97,4 | 0,79 | 0,85 | 0,87 | 204 |
| 1000 | 1350 | W22Xd 500K/H (1) | 6388 | 6,0 | 0,6 | 2,3 | 61,1 | 13 | 27 | 10000 | 80 | 1495 | 96,9 | 97,4 | 97,5 | 0,84 | 0,88 | 0,89 | 222 |
| 1120 | 1515 | W22Xd 500K/H (1) | 7155 | 6,0 | 0,6 | 2,3 | 65,0 | 12 | 27 | 10250 | 80 | 1495 | 97,0 | 97,5 | 97,6 | 0,84 | 0,88 | 0,89 | 248 |
| 1250 | 1690 | W22Xd 500K/H (1) | 7985 | 6,1 | 0,6 | 2,3 | 69,4 | 11 | 25 | 10500 | 80 | 1495 | 97,1 | 97,6 | 97,7 | 0,83 | 0,88 | 0,89 | 277 |
| 1400 | 1890 | W22Xd 500K/H (1) | 8943 | 6,4 | 0,6 | 2,3 | 72,2 | 10 | 22 | 11000 | 80 | 1495 | 97,1 | 97,6 | 97,7 | 0,83 | 0,88 | 0,89 | 310 |
| 1400 | 1890 | W22Xd 560H/G (1) | 8937 | 6,0 | 0,5 | 2,7 | 98,3 | 12 | 22 | 12360 | 86 | 1496 | 97,1 | 97,6 | 97,7 | 0,82 | 0,87 | 0,88 | 313 |
| 1600 | 2160 | W22Xd 560H/G (1) | 10214 | 6,0 | 0,5 | 2,7 | 103 | 12 | 22 | 12720 | 86 | 1496 | 97,2 | 97,7 | 97,8 | 0,82 | 0,87 | 0,88 | 358 |

W22Xd Rib-Cooled Series / Standard - Anti-friction bearings arrangement

| Output | | Frame IEC | T _n (Nm) | I _s /I _n | T _s /T _n | T _{max} /T _n | Inertia J (Kgm ²) | Allowable locked rotor time Hot/ Cold (s) | Weight (Kg) | Sound Pressure dB(A) | RPM | Y 3000V/50Hz | | | | | | I _n (A) |
|--------|----|-----------|------------------------|--------------------------------|--------------------------------|----------------------------------|----------------------------------|--|----------------|----------------------------|-----|------------------|--|--|--------------------|--|--|--------------------|
| kW | HP | | | | | | | | | | | % of full load | | | | | | |
| | | | | | | | | | | | | Efficiency η (%) | | | Power Factor Cos φ | | | |
| | | 50 | 75 | 100 | 50 | 75 | 100 | | | | | | | | | | | |

VI Pole - 1000 min⁻¹

| | | | | | | | | | | | | | | | | | | | |
|------|------|------------------|-------|-----|-----|-----|------|----|----|-------|----|-----|------|------|------|------|------|------|------|
| 90 | 120 | W22Xd 315L | 864 | 6,7 | 1,2 | 2,4 | 4,2 | 18 | 40 | 1850 | 69 | 995 | 93,4 | 94,5 | 94,6 | 0,59 | 0,69 | 0,75 | 24,4 |
| 110 | 150 | W22Xd 315L | 1056 | 6,7 | 1,2 | 2,4 | 4,6 | 18 | 40 | 1950 | 69 | 995 | 93,6 | 94,6 | 94,7 | 0,59 | 0,69 | 0,75 | 29,8 |
| 132 | 180 | W22Xd 355M/L | 1269 | 6,0 | 1,3 | 2,3 | 6,9 | 20 | 40 | 2250 | 69 | 993 | 94,7 | 95,5 | 95,5 | 0,65 | 0,75 | 0,80 | 33,3 |
| 160 | 215 | W22Xd 355M/L | 1539 | 6,0 | 1,4 | 2,3 | 7,7 | 20 | 40 | 2350 | 69 | 993 | 94,9 | 95,5 | 95,6 | 0,65 | 0,75 | 0,80 | 40,3 |
| 200 | 270 | W22Xd 355A/B | 1923 | 6,3 | 1,5 | 2,3 | 9,3 | 20 | 40 | 2600 | 69 | 993 | 95,0 | 95,6 | 95,7 | 0,65 | 0,75 | 0,80 | 50,3 |
| 250 | 340 | W22Xd 355A/B | 2404 | 6,3 | 1,5 | 2,3 | 10,0 | 20 | 40 | 2700 | 69 | 993 | 95,1 | 95,7 | 95,7 | 0,65 | 0,75 | 0,80 | 62,8 |
| 280 | 380 | W22Xd 355A/B | 2693 | 6,3 | 1,5 | 2,3 | 10,8 | 19 | 38 | 2850 | 69 | 993 | 95,4 | 95,9 | 95,9 | 0,65 | 0,75 | 0,80 | 70,2 |
| 315 | 425 | W22Xd 355A/B | 3029 | 6,3 | 1,5 | 2,3 | 11,6 | 19 | 38 | 3050 | 69 | 993 | 95,5 | 96,0 | 96,0 | 0,66 | 0,75 | 0,80 | 78,9 |
| 355 | 480 | W22Xd 400L/J | 3421 | 6,2 | 1,0 | 2,3 | 22,9 | 16 | 35 | 4200 | 75 | 991 | 96,1 | 96,4 | 96,5 | 0,72 | 0,78 | 0,82 | 85,3 |
| 400 | 540 | W22Xd 400L/J | 3855 | 6,2 | 1,0 | 2,3 | 24,5 | 15 | 32 | 4400 | 75 | 991 | 96,2 | 96,6 | 96,5 | 0,73 | 0,80 | 0,82 | 97,3 |
| 450 | 610 | W22Xd 400G (1) | 4319 | 6,0 | 0,6 | 2,3 | 28,0 | 18 | 37 | 4800 | 75 | 995 | 95,6 | 96,0 | 96,2 | 0,81 | 0,82 | 0,83 | 108 |
| 500 | 675 | W22Xd 400G (1) | 4799 | 6,0 | 0,7 | 2,3 | 32,0 | 18 | 37 | 4850 | 75 | 995 | 95,5 | 96,0 | 96,2 | 0,80 | 0,82 | 0,83 | 121 |
| 560 | 755 | W22Xd 400G (1) | 5375 | 6,0 | 0,7 | 2,3 | 33,5 | 16 | 33 | 4900 | 75 | 995 | 95,9 | 96,2 | 96,4 | 0,80 | 0,82 | 0,83 | 135 |
| 630 | 850 | W22Xd 450K/H (1) | 6047 | 6,0 | 0,7 | 3,0 | 52,0 | 20 | 40 | 6600 | 76 | 995 | 96,1 | 96,8 | 97,0 | 0,73 | 0,81 | 0,85 | 147 |
| 710 | 960 | W22Xd 450K/H (1) | 6815 | 6,0 | 0,7 | 3,0 | 54,6 | 19 | 38 | 6800 | 76 | 995 | 96,3 | 96,9 | 97,1 | 0,74 | 0,82 | 0,85 | 166 |
| 800 | 1080 | W22Xd 500K/H (1) | 7663 | 6,0 | 0,7 | 2,7 | 93,5 | 19 | 37 | 10400 | 80 | 997 | 96,9 | 97,2 | 97,3 | 0,78 | 0,84 | 0,86 | 184 |
| 900 | 1215 | W22Xd 500K/H (1) | 8621 | 6,1 | 0,8 | 2,7 | 105 | 19 | 36 | 10650 | 80 | 997 | 96,9 | 97,2 | 97,3 | 0,78 | 0,85 | 0,86 | 207 |
| 1000 | 1350 | W22Xd 500K/H (1) | 9579 | 6,1 | 0,8 | 2,7 | 108 | 18 | 34 | 11100 | 80 | 997 | 96,8 | 97,2 | 97,3 | 0,77 | 0,84 | 0,86 | 230 |
| 1120 | 1515 | W22Xd 500K/H (1) | 10728 | 6,2 | 0,8 | 2,7 | 109 | 16 | 31 | 11500 | 80 | 997 | 96,8 | 97,3 | 97,4 | 0,76 | 0,84 | 0,86 | 257 |
| 1120 | 1515 | W22Xd 560H/G (1) | 10728 | 6,0 | 0,6 | 2,6 | 164 | 18 | 37 | 12600 | 82 | 997 | 96,9 | 97,4 | 97,5 | 0,77 | 0,84 | 0,86 | 257 |
| 1250 | 1690 | W22Xd 560H/G (1) | 11973 | 6,0 | 0,6 | 2,6 | 172 | 15 | 32 | 12960 | 82 | 997 | 97,0 | 97,4 | 97,5 | 0,79 | 0,85 | 0,86 | 287 |

VIII Pole - 750 min⁻¹

| | | | | | | | | | | | | | | | | | | | |
|------|------|------------------|-------|-----|-----|-----|------|----|----|-------|----|-----|------|------|------|------|------|------|------|
| 90 | 120 | W22Xd 315L | 1158 | 7,5 | 1,4 | 2,4 | 3,8 | 17 | 37 | 2050 | 65 | 742 | 89,3 | 91,3 | 92,0 | 0,50 | 0,63 | 0,71 | 26,5 |
| 110 | 150 | W22Xd 355M/L | 1420 | 6,8 | 1,3 | 2,4 | 7,5 | 18 | 40 | 2450 | 65 | 740 | 94,0 | 94,5 | 94,5 | 0,69 | 0,77 | 0,80 | 28,0 |
| 132 | 180 | W22Xd 355M/L | 1704 | 6,8 | 1,3 | 2,4 | 8,1 | 18 | 40 | 2650 | 65 | 740 | 94,4 | 94,6 | 94,6 | 0,71 | 0,78 | 0,80 | 33,6 |
| 160 | 215 | W22Xd 355A/B | 2065 | 6,8 | 1,3 | 2,4 | 8,9 | 18 | 40 | 2950 | 65 | 740 | 94,6 | 94,7 | 94,7 | 0,71 | 0,78 | 0,80 | 40,6 |
| 200 | 270 | W22Xd 400L/J (1) | 2581 | 5,0 | 0,6 | 2,1 | 35,2 | 18 | 40 | 4000 | 74 | 740 | 95,7 | 96,2 | 96,4 | 0,73 | 0,80 | 0,82 | 48,7 |
| 250 | 340 | W22Xd 400L/J (1) | 3226 | 5,0 | 0,6 | 2,1 | 36,9 | 18 | 40 | 4200 | 74 | 740 | 95,7 | 96,2 | 96,4 | 0,73 | 0,80 | 0,82 | 60,9 |
| 280 | 380 | W22Xd 400L/J (1) | 3614 | 5,0 | 0,6 | 2,1 | 38,1 | 18 | 40 | 4400 | 74 | 740 | 95,7 | 96,2 | 96,4 | 0,73 | 0,80 | 0,82 | 68,2 |
| 315 | 425 | W22Xd 400G (1) | 4065 | 5,0 | 0,6 | 2,1 | 41,5 | 17 | 37 | 5050 | 74 | 740 | 95,8 | 96,3 | 96,4 | 0,71 | 0,79 | 0,82 | 76,7 |
| 355 | 480 | W22Xd 400G (1) | 4581 | 5,0 | 0,6 | 2,1 | 43,5 | 17 | 37 | 5150 | 74 | 740 | 95,8 | 96,3 | 96,4 | 0,69 | 0,78 | 0,82 | 86,4 |
| 400 | 540 | W22Xd 400G (1) | 5162 | 5,0 | 0,6 | 2,1 | 45,6 | 17 | 37 | 5200 | 74 | 740 | 95,9 | 96,4 | 96,4 | 0,73 | 0,80 | 0,82 | 97,4 |
| 450 | 610 | W22Xd 450K/H (1) | 5768 | 5,0 | 0,6 | 2,4 | 53,8 | 17 | 32 | 6400 | 75 | 745 | 95,8 | 96,4 | 96,5 | 0,69 | 0,79 | 0,82 | 109 |
| 500 | 675 | W22Xd 450K/H (1) | 6409 | 5,0 | 0,6 | 2,4 | 56,5 | 15 | 29 | 6700 | 75 | 745 | 95,8 | 96,4 | 96,5 | 0,71 | 0,80 | 0,82 | 122 |
| 560 | 755 | W22Xd 450K/H (1) | 7179 | 5,0 | 0,6 | 2,4 | 57,5 | 15 | 29 | 7000 | 75 | 745 | 95,8 | 96,4 | 96,5 | 0,71 | 0,79 | 0,82 | 136 |
| 630 | 850 | W22Xd 500K/H (1) | 8065 | 5,5 | 0,8 | 2,4 | 133 | 18 | 37 | 10500 | 80 | 746 | 96,7 | 97,0 | 97,0 | 0,73 | 0,80 | 0,80 | 156 |
| 710 | 960 | W22Xd 500K/H (1) | 9089 | 5,5 | 0,8 | 2,4 | 136 | 18 | 35 | 10600 | 80 | 746 | 96,7 | 97,0 | 97,0 | 0,72 | 0,79 | 0,80 | 176 |
| 800 | 1080 | W22Xd 500K/H (1) | 10241 | 5,5 | 0,8 | 2,3 | 147 | 17 | 34 | 11200 | 80 | 746 | 96,8 | 97,0 | 97,0 | 0,73 | 0,80 | 0,80 | 198 |
| 900 | 1215 | W22Xd 500K/H (1) | 11521 | 5,5 | 0,8 | 2,3 | 148 | 17 | 32 | 11800 | 80 | 746 | 96,8 | 97,1 | 97,1 | 0,72 | 0,79 | 0,80 | 223 |
| 900 | 1215 | W22Xd 560H/G (1) | 11491 | 5,9 | 0,6 | 3,0 | 186 | 18 | 37 | 13540 | 82 | 748 | 96,8 | 97,3 | 97,3 | 0,66 | 0,76 | 0,80 | 223 |
| 1000 | 1350 | W22Xd 560H/G (1) | 12767 | 5,9 | 0,6 | 3,0 | 188 | 15 | 32 | 13680 | 82 | 748 | 96,9 | 97,4 | 97,4 | 0,66 | 0,76 | 0,80 | 247 |

(1) Copper rotor

T_n = Full load torque
 I_s / I_n = Locked rotor current
 T_s / T_n = Locked rotor torque
 T_{max} / T_n = Breakdown torque
 I_n = Full load current

Notes:
 -The indicated values for sound pressure levels are @ 1m no load, with 3 dB(A) tolerance.
 -All values are according to IEC 60034-1 Standard tolerances.
 -This data can be changed without prior notice.

W22Xd Rib-Cooled Series / Standard - Anti-friction bearings arrangement

| Output | | Frame IEC | T _n (Nm) | I _s /I _n | T _s /T _n | T _{max} /T _n | Inertia J (Kgm ²) | Allowable locked rotor time Hot/Cold (s) | Weight (Kg) | Sound Pressure dB(A) | RPM | Y 4160V/60Hz | | | | | | |
|--------|----|-----------|---------------------|--------------------------------|--------------------------------|----------------------------------|-------------------------------|--|-------------|----------------------|-----|------------------|--|--|--------------------|--|--|--------------------|
| kW | HP | | | | | | | | | | | % of full load | | | | | | I _n (A) |
| | | | | | | | | | | | | Efficiency η (%) | | | Power Factor Cos φ | | | |
| | | 50 | | | 75 | | | 100 | | | | | | | | | | |

II Pole - 3600 min⁻¹

| | | | | | | | | | | | | | | | | | | | |
|------|------|------------------|------------|-----|-----|-----|------|----|----|------|----|------|------|------|------|------|------|------|------|
| 90 | 120 | W22Xd 315L | 240 | 6,7 | 1,5 | 2,5 | 1,2 | 8 | 16 | 1750 | 85 | 3577 | 88,9 | 91,8 | 93,1 | 0,76 | 0,83 | 0,86 | 15,6 |
| 110 | 150 | W22Xd 315L | 294 | 6,8 | 1,6 | 2,6 | 1,3 | 6 | 12 | 1800 | 85 | 3577 | 90,0 | 92,6 | 93,7 | 0,76 | 0,83 | 0,86 | 18,9 |
| 132 | 180 | W22Xd 315L | 352 | 6,8 | 1,6 | 2,6 | 1,4 | 6 | 12 | 1850 | 85 | 3577 | 90,7 | 93,1 | 94,2 | 0,76 | 0,83 | 0,86 | 22,6 |
| 160 | 215 | W22Xd 355M/L | 426 | 7,0 | 1,3 | 3,0 | 2,9 | 12 | 24 | 2000 | 85 | 3585 | 91,5 | 93,5 | 94,2 | 0,81 | 0,87 | 0,88 | 26,8 |
| 200 | 270 | W22Xd 355M/L | 533 | 7,0 | 1,3 | 3,0 | 3,3 | 11 | 22 | 2100 | 85 | 3585 | 92,5 | 94,2 | 94,8 | 0,81 | 0,87 | 0,89 | 32,9 |
| 250 | 340 | W22Xd 355M/L | 666 | 7,0 | 1,3 | 3,0 | 4,3 | 11 | 22 | 2300 | 85 | 3585 | 93,4 | 94,7 | 95,2 | 0,83 | 0,88 | 0,89 | 41,0 |
| 280 | 380 | W22Xd 355A/B | 746 | 7,0 | 1,4 | 3,0 | 4,8 | 10 | 20 | 2600 | 85 | 3585 | 93,9 | 95,1 | 95,5 | 0,85 | 0,89 | 0,90 | 45,2 |
| 315 | 425 | W22Xd 355A/B | 839 | 7,0 | 1,4 | 3,0 | 5,1 | 9 | 18 | 2700 | 85 | 3585 | 94,4 | 95,5 | 95,8 | 0,85 | 0,89 | 0,90 | 50,7 |
| 355 | 480 | W22Xd 355A/B | 946 | 7,0 | 1,5 | 3,0 | 5,4 | 7 | 14 | 2850 | 85 | 3585 | 94,7 | 95,7 | 96,0 | 0,85 | 0,89 | 0,90 | 57,0 |
| 400 | 540 | W22Xd 355A/B | 1066 | 7,0 | 1,5 | 3,0 | 5,8 | 7 | 14 | 3050 | 85 | 3585 | 94,8 | 95,8 | 96,2 | 0,85 | 0,89 | 0,90 | 64,1 |
| 450 | 610 | W22Xd 400L/J | 1199 | 7,0 | 1,7 | 2,8 | 9,9 | 6 | 13 | 4050 | 85 | 3585 | 94,8 | 95,9 | 96,3 | 0,82 | 0,87 | 0,88 | 73,7 |
| 500 | 675 | W22Xd 400L/J | 1332 | 7,0 | 1,7 | 2,8 | 10,2 | 6 | 12 | 4100 | 85 | 3585 | 95,1 | 96,1 | 96,4 | 0,82 | 0,87 | 0,88 | 81,8 |
| 560 | 755 | W22Xd 400G | 1492 | 7,0 | 1,7 | 2,8 | 11,5 | 6 | 12 | 4900 | 85 | 3585 | 95,3 | 96,2 | 96,5 | 0,82 | 0,87 | 0,88 | 91,5 |
| 630 | 850 | W22Xd 400G | 1678 | 7,0 | 1,7 | 2,8 | 12,5 | 6 | 12 | 5200 | 85 | 3585 | 95,3 | 96,2 | 96,5 | 0,82 | 0,87 | 0,88 | 103 |
| 710 | 960 | W22Xd 400G (1) | 1889 | 6,0 | 1,0 | 2,8 | 13,5 | 6 | 14 | 5400 | 85 | 3589 | 96,3 | 97,0 | 97,2 | 0,87 | 0,90 | 0,90 | 113 |
| 800 | 1080 | W22Xd 450K/H (1) | 2128 | 6,0 | 0,6 | 2,6 | 14,3 | 12 | 40 | 6400 | 85 | 3590 | 96,3 | 97,0 | 97,2 | 0,85 | 0,89 | 0,90 | 127 |
| 900 | 1215 | W22Xd 450K/H (1) | 2394 | 6,0 | 0,6 | 2,6 | 15,2 | 10 | 36 | 6650 | 85 | 3590 | 96,4 | 97,2 | 97,4 | 0,85 | 0,89 | 0,90 | 142 |
| 1000 | 1350 | W22Xd 500K/H (1) | On request | | | | | | | | | | | | | | | | |
| 1120 | 1515 | W22Xd 500K/H (1) | | | | | | | | | | | | | | | | | |
| 1120 | 1515 | W22Xd 560H/G (1) | | | | | | | | | | | | | | | | | |
| 1250 | 1690 | W22Xd 560H/G (1) | | | | | | | | | | | | | | | | | |

IV Pole - 1800 min⁻¹

| | | | | | | | | | | | | | | | | | | | |
|------|------|------------------|------|-----|-----|-----|------|----|----|-------|----|------|------|------|------|------|------|------|------|
| 90 | 120 | W22Xd 315L | 483 | 6,5 | 1,1 | 2,3 | 2,3 | 20 | 40 | 1725 | 81 | 1781 | 91,4 | 93,3 | 94,0 | 0,73 | 0,82 | 0,85 | 15,6 |
| 110 | 150 | W22Xd 315L | 590 | 6,5 | 1,1 | 2,3 | 2,6 | 15 | 32 | 1785 | 81 | 1781 | 92,2 | 93,8 | 94,4 | 0,73 | 0,82 | 0,85 | 19,0 |
| 132 | 180 | W22Xd 315L | 708 | 6,5 | 1,1 | 2,3 | 2,8 | 15 | 32 | 1825 | 81 | 1781 | 92,6 | 94,0 | 94,6 | 0,73 | 0,82 | 0,85 | 22,8 |
| 160 | 215 | W22Xd 355M/L | 853 | 6,5 | 1,4 | 2,8 | 4,8 | 18 | 39 | 2100 | 81 | 1791 | 91,4 | 93,8 | 94,7 | 0,70 | 0,80 | 0,84 | 27,9 |
| 200 | 270 | W22Xd 355M/L | 1066 | 6,5 | 1,4 | 2,8 | 5,4 | 16 | 34 | 2200 | 81 | 1791 | 92,1 | 94,3 | 95,2 | 0,70 | 0,80 | 0,84 | 34,7 |
| 250 | 340 | W22Xd 355A/B | 1333 | 7,0 | 1,4 | 2,8 | 6,3 | 13 | 25 | 2300 | 81 | 1791 | 94,1 | 95,5 | 95,8 | 0,74 | 0,82 | 0,85 | 42,6 |
| 280 | 380 | W22Xd 355A/B | 1493 | 7,0 | 1,4 | 2,8 | 7,3 | 12 | 23 | 2775 | 81 | 1791 | 94,1 | 95,5 | 95,8 | 0,74 | 0,82 | 0,85 | 47,7 |
| 315 | 425 | W22Xd 355A/B | 1680 | 7,0 | 1,4 | 2,8 | 7,5 | 12 | 23 | 2900 | 81 | 1791 | 94,4 | 95,6 | 95,9 | 0,74 | 0,82 | 0,85 | 53,6 |
| 355 | 480 | W22Xd 355A/B | 1893 | 7,0 | 1,5 | 2,8 | 8,2 | 10 | 21 | 3050 | 81 | 1791 | 94,5 | 95,7 | 96,0 | 0,74 | 0,82 | 0,85 | 60,4 |
| 400 | 540 | W22Xd 355A/B | 2133 | 7,0 | 1,5 | 2,8 | 8,7 | 10 | 21 | 3250 | 81 | 1791 | 94,5 | 95,7 | 96,0 | 0,74 | 0,82 | 0,85 | 68,0 |
| 450 | 610 | W22Xd 400L/J | 2399 | 6,4 | 1,3 | 2,7 | 19,1 | 13 | 25 | 4200 | 85 | 1791 | 95,0 | 96,0 | 96,2 | 0,79 | 0,85 | 0,86 | 75,5 |
| 500 | 675 | W22Xd 400L/J | 2666 | 6,4 | 1,3 | 2,7 | 20,1 | 13 | 25 | 4350 | 85 | 1791 | 95,0 | 96,0 | 96,2 | 0,79 | 0,85 | 0,86 | 83,9 |
| 560 | 755 | W22Xd 400G (1) | 2986 | 5,8 | 0,5 | 2,6 | 23,2 | 20 | 40 | 5150 | 85 | 1791 | 95,8 | 96,3 | 96,5 | 0,81 | 0,87 | 0,88 | 91,5 |
| 630 | 850 | W22Xd 400G (1) | 3359 | 5,8 | 0,5 | 2,6 | 25,9 | 17 | 34 | 5350 | 85 | 1791 | 95,9 | 96,3 | 96,5 | 0,82 | 0,87 | 0,88 | 103 |
| 710 | 960 | W22Xd 400G (1) | 3786 | 5,9 | 0,6 | 2,7 | 27,1 | 15 | 30 | 5540 | 85 | 1791 | 96,2 | 96,6 | 96,7 | 0,82 | 0,87 | 0,88 | 116 |
| 800 | 1080 | W22Xd 400G (1) | 4266 | 5,9 | 0,6 | 2,7 | 27,6 | 12 | 23 | 5600 | 85 | 1791 | 96,3 | 96,7 | 96,8 | 0,82 | 0,87 | 0,88 | 130 |
| 900 | 1215 | W22Xd 450K/H (1) | 4794 | 6,0 | 0,7 | 2,5 | 28,2 | 17 | 34 | 6700 | 85 | 1793 | 96,5 | 97,0 | 97,1 | 0,79 | 0,85 | 0,87 | 148 |
| 1000 | 1350 | W22Xd 450K/H (1) | 5326 | 6,1 | 0,7 | 2,6 | 29,6 | 15 | 30 | 7000 | 85 | 1793 | 96,6 | 97,1 | 97,2 | 0,79 | 0,85 | 0,87 | 164 |
| 1120 | 1515 | W22Xd 500K/H (1) | 5962 | 6,0 | 0,6 | 2,3 | 61,1 | 14 | 28 | 10000 | 85 | 1794 | 96,8 | 97,2 | 97,3 | 0,84 | 0,88 | 0,89 | 179 |
| 1250 | 1690 | W22Xd 500K/H (1) | 6654 | 6,0 | 0,6 | 2,3 | 65,0 | 12 | 24 | 10250 | 85 | 1794 | 96,9 | 97,3 | 97,4 | 0,84 | 0,88 | 0,89 | 200 |
| 1400 | 1890 | W22Xd 500K/H (1) | 7453 | 6,0 | 0,6 | 2,3 | 69,4 | 10 | 20 | 10500 | 85 | 1794 | 96,9 | 97,4 | 97,5 | 0,84 | 0,88 | 0,89 | 224 |
| 1400 | 1890 | W22Xd 560H/G (1) | 7444 | 6,0 | 0,5 | 2,7 | 98,3 | 14 | 28 | 12360 | 91 | 1796 | 96,5 | 96,8 | 97,1 | 0,83 | 0,88 | 0,88 | 227 |
| 1600 | 2160 | W22Xd 560H/G (1) | 8508 | 6,0 | 0,5 | 2,7 | 103 | 12 | 24 | 12720 | 91 | 1796 | 96,5 | 97,0 | 97,2 | 0,83 | 0,88 | 0,88 | 260 |

W22Xd Rib-Cooled Series / Standard - Anti-friction bearings arrangement

| Output | | Frame IEC | T _n (Nm) | I _s /I _n | T _s /T _n | T _{max} /T _n | Inertia J (Kgm ²) | Allowable locked rotor time Hot/Cold (s) | Weight (Kg) | Sound Pressure dB(A) | RPM | Y 4160V/60Hz | | | | | | I _n (A) | |
|--|------|------------------|---------------------|--------------------------------|--------------------------------|----------------------------------|-------------------------------|--|-------------|----------------------|-----|------------------|------|------|--------------------|------|------|--------------------|------|
| kW | HP | | | | | | | | | | | % of full load | | | | | | | |
| | | | | | | | | | | | | Efficiency η (%) | | | Power Factor Cos φ | | | | |
| | | 50 | 75 | 100 | 50 | 75 | 100 | | | | | | | | | | | | |
| VI Pole - 1200 min⁻¹ | | | | | | | | | | | | | | | | | | | |
| 90 | 120 | W22Xd 315L | 719 | 6,5 | 1,2 | 2,4 | 3,9 | 18 | 40 | 1750 | 74 | 1195 | 92,9 | 94,2 | 94,6 | 0,60 | 0,70 | 0,75 | 17,6 |
| 110 | 150 | W22Xd 315L | 879 | 6,5 | 1,2 | 2,4 | 4,3 | 18 | 40 | 1850 | 74 | 1195 | 92,9 | 94,2 | 94,6 | 0,60 | 0,70 | 0,75 | 21,5 |
| 132 | 180 | W22Xd 355M/L | 1057 | 6,0 | 1,4 | 2,2 | 6,2 | 15 | 36 | 2150 | 74 | 1193 | 93,8 | 94,8 | 95,0 | 0,65 | 0,75 | 0,80 | 24,1 |
| 160 | 215 | W22Xd 355M/L | 1281 | 6,0 | 1,4 | 2,2 | 6,4 | 14 | 34 | 2250 | 74 | 1193 | 94,1 | 95,1 | 95,3 | 0,65 | 0,75 | 0,80 | 29,1 |
| 200 | 270 | W22Xd 355A/B | 1601 | 6,0 | 1,4 | 2,2 | 7,7 | 13 | 32 | 2500 | 74 | 1193 | 94,3 | 95,3 | 95,5 | 0,65 | 0,75 | 0,80 | 36,3 |
| 250 | 340 | W22Xd 355A/B | 2001 | 6,0 | 1,4 | 2,2 | 9,3 | 12 | 30 | 2600 | 74 | 1193 | 94,5 | 95,5 | 95,7 | 0,65 | 0,75 | 0,80 | 45,3 |
| 280 | 380 | W22Xd 355A/B | 2241 | 6,2 | 1,5 | 2,3 | 10,0 | 12 | 30 | 2700 | 74 | 1193 | 94,6 | 95,6 | 95,8 | 0,65 | 0,75 | 0,80 | 50,7 |
| 315 | 425 | W22Xd 355A/B | 2522 | 6,5 | 1,5 | 2,3 | 10,8 | 11 | 28 | 2850 | 74 | 1193 | 94,6 | 95,6 | 95,8 | 0,65 | 0,75 | 0,80 | 57,0 |
| 355 | 480 | W22Xd 355A/B | 2842 | 6,5 | 1,5 | 2,3 | 11,6 | 10 | 26 | 3050 | 74 | 1193 | 94,9 | 95,7 | 95,8 | 0,65 | 0,75 | 0,80 | 64,3 |
| 400 | 540 | W22Xd 400L/J | 3207 | 6,5 | 0,9 | 2,3 | 22,9 | 15 | 32 | 4200 | 80 | 1191 | 95,6 | 96,1 | 96,1 | 0,73 | 0,81 | 0,83 | 69,6 |
| 450 | 610 | W22Xd 400G (1) | 3608 | 6,0 | 0,6 | 2,2 | 25,3 | 18 | 40 | 4550 | 80 | 1191 | 95,2 | 95,9 | 96,1 | 0,80 | 0,82 | 0,83 | 78,3 |
| 500 | 675 | W22Xd 400G (1) | 4009 | 6,0 | 0,6 | 2,2 | 28,0 | 15 | 33 | 4800 | 80 | 1191 | 95,2 | 95,9 | 96,1 | 0,80 | 0,82 | 0,83 | 87,0 |
| 560 | 755 | W22Xd 400G (1) | 4490 | 6,0 | 0,6 | 2,2 | 32,0 | 13 | 27 | 4850 | 80 | 1191 | 95,4 | 96,0 | 96,2 | 0,80 | 0,82 | 0,83 | 97,3 |
| 630 | 850 | W22Xd 400G (1) | 5052 | 6,2 | 0,7 | 2,3 | 33,5 | 11 | 22 | 4900 | 80 | 1191 | 95,4 | 96,1 | 96,2 | 0,80 | 0,82 | 0,83 | 110 |
| 710 | 960 | W22Xd 450K/H (1) | 5674 | 6,0 | 0,7 | 3,0 | 52,1 | 15 | 32 | 6600 | 81 | 1195 | 95,0 | 96,0 | 96,2 | 0,74 | 0,82 | 0,85 | 121 |
| 800 | 1080 | W22Xd 450K/H (1) | 6393 | 6,0 | 0,7 | 3,0 | 54,7 | 15 | 32 | 6800 | 81 | 1195 | 95,2 | 96,1 | 96,2 | 0,76 | 0,83 | 0,85 | 136 |
| 900 | 1215 | W22Xd 500K/H (1) | 7186 | 6,2 | 0,7 | 2,7 | 93,5 | 19 | 34 | 10400 | 85 | 1196 | 95,9 | 96,5 | 96,6 | 0,78 | 0,84 | 0,86 | 150 |
| 1000 | 1350 | W22Xd 500K/H (1) | 7985 | 6,1 | 0,7 | 2,7 | 105 | 19 | 34 | 10650 | 85 | 1196 | 95,9 | 96,5 | 96,6 | 0,78 | 0,84 | 0,86 | 167 |
| 1120 | 1515 | W22Xd 500K/H (1) | 8943 | 6,3 | 0,7 | 2,7 | 108 | 17 | 28 | 11100 | 85 | 1196 | 95,9 | 96,5 | 96,6 | 0,78 | 0,84 | 0,86 | 187 |
| 1120 | 1515 | W22Xd 560H/G (1) | 8936 | 5,9 | 0,6 | 2,5 | 164 | 11 | 20 | 12600 | 87 | 1197 | 96,2 | 96,8 | 96,9 | 0,78 | 0,85 | 0,85 | 189 |
| 1250 | 1690 | W22Xd 560H/G (1) | 9973 | 5,9 | 0,6 | 2,5 | 171 | 11 | 20 | 12960 | 87 | 1197 | 96,2 | 96,8 | 96,9 | 0,78 | 0,85 | 0,85 | 211 |

| | | | | | | | | | | | | | | | | | | | |
|---|------|------------------|-------|-----|-----|-----|------|----|----|-------|----|-----|------|------|------|------|------|------|------|
| VIII Pole - 900 min⁻¹ | | | | | | | | | | | | | | | | | | | |
| 90 | 120 | W22Xd 315L | 966 | 7,5 | 1,4 | 2,4 | 3,5 | 18 | 40 | 1950 | 70 | 890 | 88,7 | 91,0 | 91,7 | 0,50 | 0,63 | 0,71 | 19,2 |
| 110 | 150 | W22Xd 355M/L | 1183 | 6,8 | 1,3 | 2,4 | 6,9 | 18 | 40 | 2350 | 70 | 888 | 93,6 | 94,4 | 94,2 | 0,69 | 0,77 | 0,80 | 20,3 |
| 132 | 180 | W22Xd 355M/L | 1420 | 6,8 | 1,3 | 2,4 | 7,5 | 18 | 40 | 2440 | 70 | 888 | 94,0 | 94,6 | 94,3 | 0,71 | 0,78 | 0,80 | 24,3 |
| 160 | 215 | W22Xd 355M/L | 1721 | 6,8 | 1,3 | 2,4 | 8,1 | 18 | 40 | 2640 | 70 | 888 | 94,2 | 94,7 | 94,4 | 0,71 | 0,78 | 0,80 | 29,4 |
| 200 | 270 | W22Xd 400L/J (1) | 2146 | 5,0 | 0,6 | 2,1 | 31,7 | 18 | 40 | 3850 | 79 | 890 | 95,3 | 96,1 | 96,1 | 0,73 | 0,80 | 0,82 | 35,2 |
| 250 | 340 | W22Xd 400L/J (1) | 2683 | 5,0 | 0,6 | 2,1 | 35,2 | 18 | 40 | 4000 | 79 | 890 | 95,3 | 96,1 | 96,1 | 0,73 | 0,80 | 0,82 | 44,0 |
| 280 | 380 | W22Xd 400L/J (1) | 3004 | 5,0 | 0,6 | 2,1 | 36,9 | 18 | 40 | 4200 | 79 | 890 | 95,3 | 96,1 | 96,1 | 0,73 | 0,80 | 0,82 | 49,3 |
| 315 | 425 | W22Xd 400G (1) | 3380 | 5,0 | 0,6 | 2,1 | 38,1 | 17 | 38 | 4400 | 79 | 890 | 95,6 | 96,1 | 96,1 | 0,71 | 0,79 | 0,82 | 55,5 |
| 355 | 480 | W22Xd 400G (1) | 3809 | 5,0 | 0,6 | 2,1 | 39,2 | 17 | 38 | 4750 | 79 | 890 | 95,6 | 96,1 | 96,1 | 0,69 | 0,78 | 0,82 | 62,5 |
| 400 | 540 | W22Xd 400G (1) | 4292 | 5,0 | 0,6 | 2,1 | 41,5 | 17 | 38 | 5050 | 79 | 890 | 95,6 | 96,1 | 96,1 | 0,73 | 0,80 | 0,82 | 70,4 |
| 450 | 610 | W22Xd 400G (1) | 4829 | 5,0 | 0,6 | 2,1 | 43,5 | 17 | 38 | 5150 | 79 | 890 | 95,6 | 96,1 | 96,1 | 0,73 | 0,80 | 0,82 | 79,3 |
| 500 | 675 | W22Xd 450K/H (1) | 5365 | 5,2 | 0,6 | 2,4 | 53,8 | 18 | 40 | 6400 | 80 | 890 | 95,6 | 96,0 | 96,2 | 0,71 | 0,80 | 0,82 | 88,0 |
| 560 | 755 | W22Xd 450K/H (1) | 6009 | 5,2 | 0,6 | 2,4 | 56,5 | 18 | 40 | 6700 | 80 | 890 | 95,6 | 96,0 | 96,2 | 0,71 | 0,80 | 0,82 | 98,5 |
| 630 | 850 | W22Xd 450K/H (1) | 6760 | 5,2 | 0,6 | 2,4 | 60,1 | 17 | 38 | 7000 | 80 | 890 | 95,6 | 96,0 | 96,2 | 0,71 | 0,80 | 0,82 | 111 |
| 710 | 960 | W22Xd 500K/H (1) | 7568 | 5,5 | 0,8 | 2,4 | 133 | 18 | 40 | 10500 | 85 | 896 | 96,4 | 96,7 | 96,7 | 0,72 | 0,79 | 0,80 | 127 |
| 800 | 1080 | W22Xd 500K/H (1) | 8527 | 5,5 | 0,8 | 2,3 | 136 | 18 | 40 | 10600 | 85 | 896 | 96,5 | 96,7 | 96,7 | 0,73 | 0,80 | 0,80 | 144 |
| 900 | 1215 | W22Xd 500K/H (1) | 9593 | 5,5 | 0,8 | 2,3 | 147 | 17 | 38 | 11200 | 85 | 896 | 96,5 | 96,8 | 96,8 | 0,72 | 0,79 | 0,80 | 161 |
| 900 | 1215 | W22Xd 560H/G (1) | 9593 | 6,0 | 0,6 | 3,0 | 179 | 18 | 40 | 13260 | 87 | 896 | 96,5 | 97,0 | 97,1 | 0,66 | 0,76 | 0,80 | 161 |
| 1000 | 1350 | W22Xd 560H/G (1) | 10658 | 6,0 | 0,6 | 3,0 | 188 | 18 | 40 | 13680 | 87 | 896 | 96,5 | 97,0 | 97,1 | 0,66 | 0,76 | 0,80 | 179 |

(1) Copper rotor

T_n = Full load torque
 I_s / I_n = Locked rotor current
 T_s / T_n = Locked rotor torque
 T_{max} / T_n = Breakdown torque
 I_n = Full load current

Notes:
 -The indicated values for sound pressure levels are @ 1m no load, with 3 dB(A) tolerance.
 -All values are according to IEC 60034-1 Standard tolerances.
 -This data can be changed without prior notice.



W22Xd Rib-Cooled Series / Standard - Anti-friction bearings arrangement

| Output | | Frame IEC | T _n (Nm) | I _s /I _n | T _s /T _n | T _{max} /T _n | Inertia J (Kgm ²) | Allowable locked rotor time Hot/Cold (s) | Weight (Kg) | Sound Pressure dB(A) | RPM | Y 6000V/50Hz | | | | | | I _n (A) |
|--------|----|-----------|---------------------|--------------------------------|--------------------------------|----------------------------------|-------------------------------|--|-------------|----------------------|-----|------------------|--|--|--------------------|--|--|--------------------|
| kW | HP | | | | | | | | | | | % of full load | | | | | | |
| | | | | | | | | | | | | Efficiency η (%) | | | Power Factor Cos φ | | | |
| | | 50 | 75 | 100 | 50 | 75 | 100 | | | | | | | | | | | |

II Pole - 3000 min⁻¹

| | | | | | | | | | | | | | | | | | | | |
|------|------|------------------|------------|-----|-----|-----|------|----|----|------|----|------|------|------|------|------|------|------|------|
| 90 | 120 | W22Xd 315L | 289 | 6,7 | 1,5 | 2,5 | 1,3 | 7 | 15 | 1800 | 80 | 2978 | 91,5 | 93,6 | 94,5 | 0,70 | 0,81 | 0,86 | 10,7 |
| 110 | 150 | W22Xd 315L | 353 | 6,8 | 1,6 | 2,6 | 1,5 | 6 | 12 | 1850 | 80 | 2978 | 93,3 | 94,3 | 94,6 | 0,71 | 0,82 | 0,87 | 12,9 |
| 132 | 180 | W22Xd 315L | 423 | 6,8 | 1,6 | 2,6 | 1,6 | 6 | 12 | 1900 | 80 | 2978 | 93,9 | 94,6 | 94,7 | 0,72 | 0,82 | 0,87 | 15,4 |
| 160 | 215 | W22Xd 355M/L | 512 | 7,5 | 1,4 | 2,9 | 3,3 | 12 | 24 | 2100 | 80 | 2986 | 94,1 | 95,3 | 95,7 | 0,81 | 0,87 | 0,88 | 18,3 |
| 200 | 270 | W22Xd 355M/L | 640 | 7,5 | 1,4 | 2,9 | 3,7 | 10 | 20 | 2200 | 80 | 2986 | 94,5 | 95,5 | 95,9 | 0,81 | 0,86 | 0,88 | 22,8 |
| 250 | 340 | W22Xd 355A/B | 800 | 7,5 | 1,4 | 3,0 | 4,8 | 11 | 22 | 2600 | 80 | 2986 | 94,8 | 95,7 | 96,0 | 0,85 | 0,89 | 0,90 | 27,8 |
| 280 | 380 | W22Xd 355A/B | 896 | 7,5 | 1,4 | 3,0 | 5,1 | 10 | 20 | 2700 | 80 | 2986 | 95,0 | 95,9 | 96,2 | 0,85 | 0,89 | 0,90 | 31,1 |
| 315 | 425 | W22Xd 355A/B | 1007 | 7,5 | 1,5 | 3,0 | 5,4 | 9 | 18 | 2850 | 80 | 2986 | 95,1 | 96,0 | 96,3 | 0,84 | 0,88 | 0,90 | 35,0 |
| 355 | 480 | W22Xd 355A/B | 1135 | 7,5 | 1,5 | 3,1 | 5,8 | 8 | 16 | 3050 | 80 | 2986 | 95,3 | 96,1 | 96,4 | 0,83 | 0,88 | 0,90 | 39,4 |
| 400 | 540 | W22Xd 400L/J | 1279 | 6,5 | 1,5 | 2,6 | 9,9 | 8 | 16 | 4050 | 80 | 2986 | 95,5 | 96,3 | 96,6 | 0,82 | 0,87 | 0,88 | 45,3 |
| 450 | 610 | W22Xd 400L/J | 1439 | 6,5 | 1,5 | 2,6 | 10,2 | 7 | 14 | 4100 | 80 | 2986 | 95,9 | 96,6 | 96,8 | 0,83 | 0,87 | 0,88 | 50,8 |
| 500 | 675 | W22Xd 400L/J | 1599 | 6,7 | 1,7 | 2,8 | 10,8 | 6 | 12 | 4200 | 80 | 2986 | 95,9 | 96,7 | 97,0 | 0,81 | 0,86 | 0,88 | 56,4 |
| 560 | 755 | W22Xd 400G | 1791 | 6,7 | 1,7 | 2,8 | 12,5 | 6 | 12 | 5200 | 80 | 2986 | 96,3 | 96,9 | 97,0 | 0,83 | 0,87 | 0,88 | 63,1 |
| 630 | 850 | W22Xd 400G (1) | 2012 | 6,1 | 1,0 | 2,8 | 13,5 | 8 | 22 | 5400 | 80 | 2990 | 96,9 | 97,3 | 97,4 | 0,85 | 0,89 | 0,90 | 68,8 |
| 710 | 960 | W22Xd 450K/H (1) | 2267 | 6,1 | 0,7 | 2,8 | 14,3 | 14 | 36 | 6400 | 80 | 2991 | 96,8 | 97,4 | 97,6 | 0,84 | 0,89 | 0,90 | 77,8 |
| 800 | 1080 | W22Xd 450K/H (1) | 2554 | 6,1 | 0,7 | 2,8 | 15,2 | 13 | 32 | 6650 | 80 | 2991 | 96,9 | 97,5 | 97,6 | 0,84 | 0,89 | 0,90 | 87,6 |
| 900 | 1215 | W22Xd 500K/H (1) | 2875 | 5,9 | 0,6 | 2,6 | 21,7 | 14 | 36 | 9000 | 85 | 2990 | 97,0 | 97,6 | 97,7 | 0,85 | 0,90 | 0,91 | 97,4 |
| 1000 | 1350 | W22Xd 500K/H (1) | 3193 | 6,1 | 0,7 | 2,8 | 23,2 | 10 | 26 | 9200 | 85 | 2991 | 97,2 | 97,7 | 97,8 | 0,85 | 0,90 | 0,91 | 108 |
| 1120 | 1515 | W22Xd 500K/H (1) | 3576 | 6,5 | 0,8 | 3,0 | 24,7 | 8 | 20 | 9650 | 85 | 2991 | 97,2 | 97,7 | 97,9 | 0,85 | 0,90 | 0,91 | 121 |
| 1120 | 1515 | W22Xd 560H/G (1) | On request | | | | | | | | | | | | | | | | |
| 1250 | 1690 | W22Xd 560H/G (1) | On request | | | | | | | | | | | | | | | | |

IV Pole - 1500 min⁻¹

| | | | | | | | | | | | | | | | | | | | |
|------|------|------------------|-------|-----|-----|-----|------|----|----|-------|----|------|------|------|------|------|------|------|------|
| 90 | 120 | W22Xd 315L | 579 | 6,7 | 1,2 | 2,5 | 2,6 | 20 | 40 | 1785 | 76 | 1484 | 93,0 | 94,2 | 94,5 | 0,70 | 0,80 | 0,83 | 11,0 |
| 110 | 150 | W22Xd 315L | 708 | 6,7 | 1,3 | 2,5 | 2,8 | 15 | 32 | 1825 | 76 | 1484 | 93,0 | 94,2 | 94,5 | 0,70 | 0,80 | 0,83 | 13,4 |
| 132 | 180 | W22Xd 315L | 849 | 6,7 | 1,3 | 2,5 | 3,1 | 15 | 32 | 1875 | 76 | 1484 | 93,0 | 94,2 | 94,6 | 0,70 | 0,80 | 0,83 | 16,1 |
| 160 | 215 | W22Xd 355M/L | 1025 | 6,7 | 1,5 | 2,9 | 5,4 | 18 | 39 | 2200 | 76 | 1491 | 94,5 | 95,5 | 95,8 | 0,73 | 0,81 | 0,84 | 19,1 |
| 200 | 270 | W22Xd 355M/L | 1281 | 6,7 | 1,5 | 2,9 | 6,3 | 16 | 34 | 2300 | 76 | 1491 | 95,1 | 95,9 | 96,1 | 0,73 | 0,81 | 0,84 | 23,8 |
| 250 | 340 | W22Xd 355A/B | 1601 | 7,2 | 1,5 | 2,9 | 7,3 | 11 | 23 | 2775 | 76 | 1491 | 95,1 | 95,9 | 96,1 | 0,71 | 0,80 | 0,84 | 29,9 |
| 280 | 380 | W22Xd 355A/B | 1793 | 7,2 | 1,5 | 2,9 | 7,5 | 10 | 21 | 2900 | 76 | 1491 | 95,4 | 96,1 | 96,2 | 0,73 | 0,82 | 0,84 | 33,3 |
| 315 | 425 | W22Xd 355A/B | 2018 | 7,2 | 1,6 | 2,9 | 8,2 | 9 | 19 | 3050 | 76 | 1491 | 95,4 | 96,2 | 96,3 | 0,72 | 0,81 | 0,84 | 37,5 |
| 355 | 480 | W22Xd 355A/B | 2274 | 7,2 | 1,6 | 2,9 | 8,7 | 9 | 19 | 3250 | 76 | 1491 | 95,4 | 96,2 | 96,3 | 0,71 | 0,80 | 0,84 | 42,2 |
| 400 | 540 | W22Xd 400L/J | 2559 | 6,5 | 1,4 | 2,8 | 19,1 | 12 | 28 | 4200 | 80 | 1493 | 95,0 | 96,0 | 96,3 | 0,77 | 0,84 | 0,86 | 46,5 |
| 450 | 610 | W22Xd 400L/J | 2878 | 6,5 | 1,4 | 2,8 | 20,1 | 11 | 25 | 4350 | 80 | 1493 | 95,1 | 96,1 | 96,4 | 0,77 | 0,84 | 0,86 | 52,2 |
| 500 | 675 | W22Xd 400L/J | 3198 | 6,5 | 1,4 | 2,8 | 21,3 | 10 | 23 | 4550 | 80 | 1493 | 95,4 | 96,3 | 96,6 | 0,77 | 0,84 | 0,86 | 57,9 |
| 560 | 755 | W22Xd 400G (1) | 3584 | 6,1 | 0,7 | 2,8 | 25,9 | 13 | 26 | 5350 | 80 | 1492 | 96,4 | 96,9 | 97,0 | 0,82 | 0,88 | 0,89 | 62,4 |
| 630 | 850 | W22Xd 400G (1) | 4033 | 6,0 | 0,7 | 2,8 | 27,1 | 11 | 23 | 5540 | 80 | 1492 | 96,6 | 97,0 | 97,0 | 0,82 | 0,88 | 0,89 | 70,2 |
| 710 | 960 | W22Xd 400G (1) | 4545 | 6,2 | 0,7 | 2,8 | 27,6 | 9 | 20 | 5600 | 80 | 1492 | 96,6 | 97,0 | 97,0 | 0,82 | 0,88 | 0,89 | 79,1 |
| 800 | 1080 | W22Xd 450K/H (1) | 5117 | 6,1 | 0,8 | 2,6 | 28,2 | 14 | 28 | 6700 | 80 | 1493 | 96,9 | 97,3 | 97,4 | 0,78 | 0,85 | 0,87 | 90,8 |
| 900 | 1215 | W22Xd 450K/H (1) | 5757 | 6,1 | 0,8 | 2,5 | 29,7 | 13 | 25 | 7000 | 80 | 1493 | 96,9 | 97,3 | 97,4 | 0,79 | 0,85 | 0,87 | 102 |
| 1000 | 1350 | W22Xd 500K/H (1) | 6388 | 6,0 | 0,6 | 2,3 | 61,1 | 13 | 27 | 10000 | 80 | 1495 | 96,9 | 97,4 | 97,5 | 0,84 | 0,88 | 0,89 | 111 |
| 1120 | 1515 | W22Xd 500K/H (1) | 7155 | 6,0 | 0,6 | 2,3 | 65,0 | 12 | 27 | 10250 | 80 | 1495 | 97,0 | 97,5 | 97,6 | 0,84 | 0,88 | 0,89 | 124 |
| 1250 | 1690 | W22Xd 500K/H (1) | 7985 | 6,1 | 0,6 | 2,3 | 69,4 | 11 | 25 | 10500 | 80 | 1495 | 97,1 | 97,6 | 97,7 | 0,83 | 0,88 | 0,89 | 138 |
| 1400 | 1890 | W22Xd 500K/H (1) | 8943 | 6,4 | 0,6 | 2,3 | 72,2 | 10 | 22 | 11000 | 80 | 1495 | 97,1 | 97,6 | 97,7 | 0,83 | 0,88 | 0,89 | 155 |
| 1400 | 1890 | W22Xd 560H/G (1) | 8937 | 6,0 | 0,5 | 2,7 | 98,3 | 12 | 22 | 12360 | 86 | 1496 | 97,1 | 97,6 | 97,7 | 0,82 | 0,87 | 0,88 | 157 |
| 1600 | 2160 | W22Xd 560H/G (1) | 10214 | 6,0 | 0,5 | 2,7 | 103 | 12 | 22 | 12720 | 86 | 1496 | 97,2 | 97,7 | 97,8 | 0,82 | 0,87 | 0,88 | 179 |

W22Xd Rib-Cooled Series / Standard - Anti-friction bearings arrangement

| Output | | Frame IEC | T _n (Nm) | I _s /I _n | T _s /T _n | T _{max} /T _n | Inertia J (Kgm²) | Allowable locked rotor time Hot/Cold (s) | Weight (Kg) | Sound Pressure dB(A) | RPM | Y 6000V/50Hz | | | | | | I _n (A) |
|--------|----|-----------|---------------------|--------------------------------|--------------------------------|----------------------------------|------------------|--|-------------|----------------------|-----|------------------|----|-----|--------------------|----|-----|--------------------|
| kW | HP | | | | | | | | | | | % of full load | | | | | | |
| | | | | | | | | | | | | Efficiency η (%) | | | Power Factor Cos φ | | | |
| | | | | | | | | | | | | 50 | 75 | 100 | 50 | 75 | 100 | |

VI Pole - 1000 min⁻¹

| | | | | | | | | | | | | | | | | | | | |
|------|------|------------------|-------|-----|-----|-----|------|----|----|-------|----|-----|------|------|------|------|------|------|------|
| 90 | 120 | W22Xd 315L | 864 | 6,7 | 1,2 | 2,4 | 4,2 | 18 | 40 | 1850 | 69 | 995 | 93,4 | 94,5 | 94,6 | 0,59 | 0,69 | 0,75 | 12,2 |
| 110 | 150 | W22Xd 315L | 1056 | 6,7 | 1,2 | 2,4 | 4,6 | 18 | 40 | 1950 | 69 | 995 | 93,6 | 94,6 | 94,7 | 0,59 | 0,69 | 0,75 | 14,9 |
| 132 | 180 | W22Xd 355M/L | 1269 | 6,0 | 1,3 | 2,3 | 6,9 | 20 | 40 | 2250 | 69 | 993 | 94,7 | 95,5 | 95,5 | 0,65 | 0,75 | 0,80 | 16,6 |
| 160 | 215 | W22Xd 355M/L | 1539 | 6,0 | 1,4 | 2,3 | 7,7 | 20 | 40 | 2350 | 69 | 993 | 94,9 | 95,5 | 95,6 | 0,65 | 0,75 | 0,80 | 20,1 |
| 200 | 270 | W22Xd 355A/B | 1923 | 6,3 | 1,5 | 2,3 | 9,3 | 20 | 40 | 2600 | 69 | 993 | 95,0 | 95,6 | 95,7 | 0,65 | 0,75 | 0,80 | 25,1 |
| 250 | 340 | W22Xd 355A/B | 2404 | 6,3 | 1,5 | 2,3 | 10,0 | 20 | 40 | 2700 | 69 | 993 | 95,1 | 95,7 | 95,7 | 0,65 | 0,75 | 0,80 | 31,4 |
| 280 | 380 | W22Xd 355A/B | 2693 | 6,3 | 1,5 | 2,3 | 10,8 | 19 | 38 | 2850 | 69 | 993 | 95,4 | 95,9 | 95,9 | 0,65 | 0,75 | 0,80 | 35,1 |
| 315 | 425 | W22Xd 355A/B | 3029 | 6,3 | 1,5 | 2,3 | 11,6 | 19 | 38 | 3050 | 69 | 993 | 95,5 | 96,0 | 96,0 | 0,66 | 0,75 | 0,80 | 39,5 |
| 355 | 480 | W22Xd 400L/J | 3421 | 6,2 | 1,0 | 2,3 | 22,9 | 16 | 35 | 4200 | 75 | 991 | 96,1 | 96,4 | 96,5 | 0,72 | 0,78 | 0,82 | 43,2 |
| 400 | 540 | W22Xd 400L/J | 3855 | 6,2 | 1,0 | 2,3 | 24,5 | 15 | 32 | 4400 | 75 | 991 | 96,2 | 96,6 | 96,5 | 0,73 | 0,80 | 0,82 | 48,6 |
| 450 | 610 | W22Xd 400G (1) | 4319 | 6,0 | 0,6 | 2,3 | 28,0 | 18 | 37 | 4800 | 75 | 995 | 95,6 | 96,0 | 96,2 | 0,81 | 0,82 | 0,83 | 54,2 |
| 500 | 675 | W22Xd 400G (1) | 4799 | 6,0 | 0,7 | 2,3 | 32,0 | 18 | 37 | 4850 | 75 | 995 | 95,5 | 96,0 | 96,2 | 0,80 | 0,82 | 0,83 | 60,3 |
| 560 | 755 | W22Xd 400G (1) | 5375 | 6,0 | 0,7 | 2,3 | 33,5 | 16 | 33 | 4900 | 75 | 995 | 95,9 | 96,2 | 96,4 | 0,80 | 0,82 | 0,83 | 67,3 |
| 630 | 850 | W22Xd 450K/H (1) | 6047 | 6,0 | 0,7 | 3,0 | 52,0 | 20 | 40 | 6600 | 76 | 995 | 96,1 | 96,8 | 97,0 | 0,73 | 0,81 | 0,85 | 73,5 |
| 710 | 960 | W22Xd 450K/H (1) | 6815 | 6,0 | 0,7 | 3,0 | 54,6 | 19 | 38 | 6800 | 76 | 995 | 96,3 | 96,9 | 97,1 | 0,74 | 0,82 | 0,85 | 82,8 |
| 800 | 1080 | W22Xd 500K/H (1) | 7663 | 6,0 | 0,7 | 2,7 | 93,5 | 19 | 37 | 10400 | 80 | 997 | 96,9 | 97,2 | 97,3 | 0,78 | 0,84 | 0,86 | 92,0 |
| 900 | 1215 | W22Xd 500K/H (1) | 8621 | 6,1 | 0,8 | 2,7 | 105 | 19 | 36 | 10650 | 80 | 997 | 96,9 | 97,2 | 97,3 | 0,78 | 0,85 | 0,86 | 103 |
| 1000 | 1350 | W22Xd 500K/H (1) | 9579 | 6,1 | 0,8 | 2,7 | 108 | 18 | 34 | 11100 | 80 | 997 | 96,8 | 97,2 | 97,3 | 0,77 | 0,84 | 0,86 | 115 |
| 1120 | 1515 | W22Xd 500K/H (1) | 10728 | 6,2 | 0,8 | 2,7 | 109 | 16 | 31 | 11500 | 80 | 997 | 96,8 | 97,3 | 97,4 | 0,76 | 0,84 | 0,86 | 129 |
| 1120 | 1515 | W22Xd 560H/G (1) | 10728 | 6,0 | 0,6 | 2,6 | 164 | 18 | 37 | 12600 | 82 | 997 | 96,9 | 97,4 | 97,5 | 0,77 | 0,84 | 0,86 | 129 |
| 1250 | 1690 | W22Xd 560H/G (1) | 11973 | 6,0 | 0,6 | 2,6 | 172 | 15 | 32 | 12960 | 82 | 997 | 97,0 | 97,4 | 97,5 | 0,79 | 0,85 | 0,86 | 143 |

VIII Pole - 750 min⁻¹

| | | | | | | | | | | | | | | | | | | | |
|------|------|------------------|-------|-----|-----|-----|------|----|----|-------|----|-----|------|------|------|------|------|------|------|
| 90 | 120 | W22Xd 315L | 1158 | 7,5 | 1,4 | 2,4 | 3,8 | 17 | 37 | 2050 | 65 | 742 | 89,3 | 91,3 | 92,0 | 0,50 | 0,63 | 0,71 | 13,3 |
| 110 | 150 | W22Xd 355M/L | 1420 | 6,8 | 1,3 | 2,4 | 7,5 | 18 | 40 | 2450 | 65 | 740 | 94,0 | 94,5 | 94,5 | 0,69 | 0,77 | 0,80 | 14,0 |
| 132 | 180 | W22Xd 355M/L | 1704 | 6,8 | 1,3 | 2,4 | 8,1 | 18 | 40 | 2650 | 65 | 740 | 94,4 | 94,6 | 94,6 | 0,71 | 0,78 | 0,80 | 16,8 |
| 160 | 215 | W22Xd 355A/B | 2065 | 6,8 | 1,3 | 2,4 | 8,9 | 18 | 40 | 2950 | 65 | 740 | 94,6 | 94,7 | 94,7 | 0,71 | 0,78 | 0,80 | 20,3 |
| 200 | 270 | W22Xd 400L/J (1) | 2581 | 5,0 | 0,6 | 2,1 | 35,2 | 18 | 40 | 4000 | 74 | 740 | 95,7 | 96,2 | 96,4 | 0,73 | 0,80 | 0,82 | 24,3 |
| 250 | 340 | W22Xd 400L/J (1) | 3226 | 5,0 | 0,6 | 2,1 | 36,9 | 18 | 40 | 4200 | 74 | 740 | 95,7 | 96,2 | 96,4 | 0,73 | 0,80 | 0,82 | 30,4 |
| 280 | 380 | W22Xd 400L/J (1) | 3614 | 5,0 | 0,6 | 2,1 | 38,1 | 18 | 40 | 4400 | 74 | 740 | 95,7 | 96,2 | 96,4 | 0,73 | 0,80 | 0,82 | 34,1 |
| 315 | 425 | W22Xd 400G (1) | 4065 | 5,0 | 0,6 | 2,1 | 41,5 | 17 | 37 | 5050 | 74 | 740 | 95,8 | 96,3 | 96,4 | 0,71 | 0,79 | 0,82 | 76,7 |
| 355 | 480 | W22Xd 400G (1) | 4581 | 5,0 | 0,6 | 2,1 | 43,5 | 17 | 37 | 5150 | 74 | 740 | 95,8 | 96,3 | 96,4 | 0,69 | 0,78 | 0,82 | 86,4 |
| 400 | 540 | W22Xd 400G (1) | 5162 | 5,0 | 0,6 | 2,1 | 45,6 | 17 | 37 | 5200 | 74 | 740 | 95,9 | 96,4 | 96,4 | 0,73 | 0,80 | 0,82 | 97,4 |
| 450 | 610 | W22Xd 450K/H (1) | 5768 | 5,0 | 0,6 | 2,4 | 53,8 | 17 | 32 | 6400 | 75 | 745 | 95,8 | 96,4 | 96,5 | 0,69 | 0,79 | 0,82 | 54,7 |
| 500 | 675 | W22Xd 450K/H (1) | 6409 | 5,0 | 0,6 | 2,4 | 56,5 | 15 | 29 | 6700 | 75 | 745 | 95,8 | 96,4 | 96,5 | 0,71 | 0,80 | 0,82 | 60,8 |
| 560 | 755 | W22Xd 450K/H (1) | 7179 | 5,0 | 0,6 | 2,4 | 57,5 | 15 | 29 | 7000 | 75 | 745 | 95,8 | 96,4 | 96,5 | 0,71 | 0,79 | 0,82 | 68,1 |
| 630 | 850 | W22Xd 500K/H (1) | 8065 | 5,5 | 0,8 | 2,4 | 133 | 18 | 37 | 10500 | 80 | 746 | 96,7 | 97,0 | 97,0 | 0,73 | 0,80 | 0,80 | 78,1 |
| 710 | 960 | W22Xd 500K/H (1) | 9089 | 5,5 | 0,8 | 2,4 | 136 | 18 | 35 | 10600 | 80 | 746 | 96,7 | 97,0 | 97,0 | 0,72 | 0,79 | 0,80 | 88,0 |
| 800 | 1080 | W22Xd 500K/H (1) | 10241 | 5,5 | 0,8 | 2,3 | 147 | 17 | 34 | 11200 | 80 | 746 | 96,8 | 97,0 | 97,0 | 0,73 | 0,80 | 0,80 | 99,2 |
| 900 | 1215 | W22Xd 500K/H (1) | 11521 | 5,5 | 0,8 | 2,3 | 148 | 17 | 32 | 11800 | 80 | 746 | 96,8 | 97,1 | 97,1 | 0,72 | 0,79 | 0,80 | 111 |
| 900 | 1215 | W22Xd 560H/G (1) | 11491 | 5,9 | 0,6 | 3,0 | 186 | 18 | 37 | 13540 | 82 | 748 | 96,8 | 97,3 | 97,3 | 0,66 | 0,76 | 0,80 | 111 |
| 1000 | 1350 | W22Xd 560H/G (1) | 12767 | 5,9 | 0,6 | 3,0 | 188 | 15 | 32 | 13680 | 82 | 748 | 96,9 | 97,4 | 97,4 | 0,66 | 0,76 | 0,80 | 123 |

(1) Copper rotor

T_n = Full load torque
 I_s / I_n = Locked rotor current
 T_s / T_n = Locked rotor torque
 T_{max} / T_n = Breakdown torque
 I_n = Full load current

Notes:
 -The indicated values for sound pressure levels are @ 1m no load, with 3 dB(A) tolerance.
 -All values are according to IEC 60034-1 Standard tolerances.
 -This data can be changed without prior notice.



6.1.2. High Voltage - Electrical Data (6600V < U ≤ 11000V)

W22Xd Rib-Cooled Series / Standard - Anti-friction bearings arrangement

| Output | | Frame IEC | T _n (Nm) | I _s /I _n | T _s /T _n | T _{max} /T _n | Inertia J (Kgm ²) | Allowable locked rotor time Hot/Cold (s) | Weight (Kg) | Sound Pressure dB(A) | RPM | Y 10000V/50Hz | | | | | | I _n (A) | |
|--|------|------------------|---------------------|--------------------------------|--------------------------------|----------------------------------|-------------------------------|--|-------------|----------------------|-----|------------------|------|------|--------------------|------|------|--------------------|------|
| kW | HP | | | | | | | | | | | % of full load | | | | | | | |
| | | | | | | | | | | | | Efficiency η (%) | | | Power Factor Cos φ | | | | |
| | | 50 | | | 75 | | | 100 | | | | | | | | | | | |
| II Pole - 3000 min⁻¹ | | | | | | | | | | | | | | | | | | | |
| 355 | 480 | W22Xd 450K/H (1) | 1134 | 6,0 | 0,6 | 2,7 | 9,0 | 15 | 36 | 6150 | 80 | 2990 | 95,4 | 96,4 | 96,7 | 0,83 | 0,88 | 0,90 | 23,6 |
| 400 | 540 | W22Xd 450K/H (1) | 1278 | 6,0 | 0,6 | 2,7 | 9,5 | 15 | 36 | 6300 | 80 | 2990 | 95,7 | 96,6 | 96,8 | 0,83 | 0,88 | 0,90 | 26,5 |
| 450 | 610 | W22Xd 450K/H (1) | 1437 | 6,0 | 0,6 | 2,7 | 10,2 | 13 | 34 | 6550 | 80 | 2990 | 96,0 | 96,8 | 97,0 | 0,83 | 0,88 | 0,90 | 29,8 |
| 500 | 675 | W22Xd 450K/H (1) | 1597 | 6,1 | 0,6 | 2,7 | 11,1 | 13 | 34 | 7050 | 80 | 2990 | 96,1 | 96,9 | 97,1 | 0,83 | 0,88 | 0,90 | 33,0 |
| 560 | 755 | W22Xd 500K/H (1) | 1789 | 6,0 | 0,7 | 2,8 | 12,7 | 14 | 38 | 9600 | 85 | 2990 | 96,3 | 97,0 | 97,2 | 0,86 | 0,90 | 0,91 | 36,6 |
| 630 | 850 | W22Xd 500K/H (1) | 2012 | 6,0 | 0,7 | 2,8 | 13,5 | 12 | 32 | 10050 | 85 | 2990 | 96,4 | 97,1 | 97,3 | 0,86 | 0,90 | 0,91 | 41,1 |
| 710 | 960 | W22Xd 500K/H (1) | 2268 | 6,0 | 0,7 | 2,8 | 19,4 | 11 | 24 | 10250 | 85 | 2990 | 96,7 | 97,2 | 97,4 | 0,87 | 0,90 | 0,91 | 46,2 |
| 710 | 960 | W22Xd 560H/G (1) | On request | | | | | | | | | | | | | | | | |
| 800 | 1080 | W22Xd 560H/G (1) | On request | | | | | | | | | | | | | | | | |
| IV Pole - 1500min⁻¹ | | | | | | | | | | | | | | | | | | | |
| 355 | 480 | W22Xd 450K/H (1) | 2269 | 5,9 | 0,6 | 2,7 | 19,8 | 10 | 18 | 6010 | 80 | 1494 | 95,6 | 96,2 | 96,3 | 0,73 | 0,82 | 0,85 | 25,0 |
| 400 | 540 | W22Xd 450K/H (1) | 2557 | 5,9 | 0,6 | 2,7 | 20,2 | 10 | 18 | 6080 | 80 | 1494 | 95,7 | 96,3 | 96,4 | 0,74 | 0,82 | 0,85 | 28,2 |
| 450 | 610 | W22Xd 450K/H (1) | 2877 | 5,9 | 0,6 | 2,7 | 21,4 | 10 | 18 | 6200 | 80 | 1494 | 96,0 | 96,5 | 96,6 | 0,74 | 0,82 | 0,85 | 31,6 |
| 500 | 675 | W22Xd 450K/H (1) | 3196 | 6,0 | 0,6 | 2,7 | 23,2 | 10 | 18 | 6400 | 80 | 1494 | 96,1 | 96,6 | 96,7 | 0,74 | 0,82 | 0,85 | 35,1 |
| 560 | 755 | W22Xd 450K/H (1) | 3580 | 6,0 | 0,7 | 2,6 | 24,6 | 10 | 18 | 7200 | 80 | 1494 | 96,4 | 96,8 | 96,8 | 0,76 | 0,83 | 0,85 | 39,3 |
| 630 | 850 | W22Xd 500K/H (1) | 4027 | 6,1 | 0,7 | 2,6 | 47,2 | 12 | 22 | 9900 | 80 | 1494 | 96,4 | 96,9 | 97,1 | 0,83 | 0,88 | 0,88 | 42,6 |
| 710 | 960 | W22Xd 500K/H (1) | 4538 | 6,0 | 0,7 | 2,5 | 51,1 | 12 | 22 | 10400 | 80 | 1494 | 96,6 | 97,1 | 97,2 | 0,83 | 0,88 | 0,88 | 47,9 |
| 800 | 1080 | W22Xd 500K/H (1) | 5114 | 6,0 | 0,7 | 2,4 | 56,1 | 12 | 22 | 10930 | 80 | 1494 | 96,8 | 97,2 | 97,3 | 0,84 | 0,88 | 0,89 | 53,3 |
| 900 | 1215 | W22Xd 500K/H (1) | 5753 | 6,0 | 0,7 | 2,4 | 61,1 | 12 | 22 | 11450 | 80 | 1494 | 96,9 | 97,3 | 97,4 | 0,84 | 0,88 | 0,89 | 59,9 |
| 900 | 1215 | W22Xd 560H/G (1) | 5749 | 5,8 | 0,5 | 2,6 | 66,1 | 12 | 22 | 11450 | 86 | 1495 | 97,0 | 97,4 | 97,5 | 0,80 | 0,85 | 0,87 | 61,3 |
| 1000 | 1350 | W22Xd 560H/G (1) | 6388 | 5,8 | 0,5 | 2,6 | 69,4 | 12 | 22 | 11900 | 86 | 1495 | 97,1 | 97,5 | 97,6 | 0,81 | 0,86 | 0,87 | 68,0 |
| 1120 | 1515 | W22Xd 560H/G (1) | 7155 | 5,9 | 0,5 | 2,7 | 74,7 | 12 | 22 | 12200 | 86 | 1495 | 97,2 | 97,6 | 97,7 | 0,81 | 0,86 | 0,87 | 76,1 |

W22Xd Rib-Cooled Series / Standard - Anti-friction bearings arrangement

| Output | | Frame IEC | T _n (Nm) | I _s /I _n | T _s /T _n | T _{max} /T _n | Inertia J (Kg·m ²) | Allowable locked rotor time Hot/ Cold (s) | Weight (Kg) | Sound Pressure dB(A) | RPM | Y 1000V/50Hz | | | | | | I _n (A) |
|--------|----|-----------|------------------------|--------------------------------|--------------------------------|----------------------------------|-----------------------------------|--|----------------|----------------------------|-----|------------------|--|--|--------------------|--|--|--------------------|
| kW | HP | | | | | | | | | | | % of full load | | | | | | |
| | | | | | | | | | | | | Efficiency η (%) | | | Power Factor Cos φ | | | |
| | | 50 | 75 | 100 | 50 | 75 | 100 | | | | | | | | | | | |

VI Pole - 1000min⁻¹

| | | | | | | | | | | | | | | | | | | | |
|-----|------|------------------|------|-----|-----|-----|------|----|----|-------|----|-----|------|------|------|------|------|------|------|
| 280 | 380 | W22Xd 450K/H (1) | 2687 | 5,5 | 0,7 | 3,1 | 36,9 | 20 | 40 | 6500 | 76 | 995 | 95,2 | 96,0 | 96,2 | 0,70 | 0,80 | 0,84 | 20,0 |
| 315 | 425 | W22Xd 450K/H (1) | 3023 | 5,5 | 0,7 | 3,1 | 39,3 | 18 | 35 | 6800 | 76 | 995 | 95,2 | 96,0 | 96,3 | 0,70 | 0,80 | 0,84 | 22,5 |
| 355 | 480 | W22Xd 450K/H (1) | 3407 | 5,5 | 0,7 | 3,1 | 39,7 | 16 | 31 | 7100 | 76 | 995 | 95,5 | 96,2 | 96,3 | 0,72 | 0,81 | 0,84 | 25,3 |
| 400 | 540 | W22Xd 450K/H (1) | 3839 | 5,5 | 0,7 | 3,1 | 40,2 | 13 | 25 | 7300 | 76 | 995 | 95,5 | 96,2 | 96,4 | 0,71 | 0,80 | 0,84 | 28,5 |
| 450 | 610 | W22Xd 450K/H (1) | 4319 | 5,5 | 0,7 | 3,1 | 41,6 | 12 | 23 | 7500 | 76 | 995 | 95,8 | 96,5 | 96,6 | 0,71 | 0,80 | 0,84 | 32,0 |
| 500 | 675 | W22Xd 500K/H (1) | 4794 | 5,7 | 0,7 | 2,5 | 56,4 | 17 | 34 | 11050 | 80 | 996 | 96,5 | 96,9 | 96,9 | 0,79 | 0,85 | 0,86 | 34,6 |
| 560 | 755 | W22Xd 500K/H (1) | 5369 | 5,7 | 0,7 | 2,5 | 59,1 | 14 | 27 | 11500 | 80 | 996 | 96,6 | 97,0 | 97,0 | 0,79 | 0,85 | 0,86 | 38,8 |
| 630 | 850 | W22Xd 500K/H (1) | 6041 | 5,9 | 0,7 | 2,5 | 64,5 | 12 | 23 | 12200 | 80 | 996 | 96,5 | 96,9 | 97,0 | 0,78 | 0,85 | 0,86 | 43,6 |
| 630 | 850 | W22Xd 560H/G (1) | 6035 | 6,0 | 0,7 | 2,5 | 97,2 | 13 | 24 | 12300 | 82 | 997 | 96,5 | 97,0 | 97,2 | 0,75 | 0,82 | 0,84 | 44,5 |
| 710 | 960 | W22Xd 560H/G (1) | 6801 | 6,0 | 0,7 | 2,5 | 102 | 11 | 21 | 12450 | 82 | 997 | 96,6 | 97,1 | 97,2 | 0,75 | 0,82 | 0,84 | 50,2 |
| 800 | 1080 | W22Xd 560H/G (1) | 7663 | 6,0 | 0,7 | 2,5 | 107 | 10 | 18 | 12900 | 82 | 997 | 96,7 | 97,2 | 97,3 | 0,75 | 0,82 | 0,84 | 56,5 |

VIII Pole - 750 min⁻¹

| | | | | | | | | | | | | | | | | | | | |
|-----|-----|------------------|------|-----|-----|-----|------|----|----|-------|----|-----|------|------|------|------|------|------|------|
| 250 | 340 | W22Xd 450K/H (1) | 3200 | 5,5 | 0,7 | 2,7 | 34,9 | 20 | 40 | 6800 | 75 | 746 | 94,8 | 95,6 | 95,8 | 0,62 | 0,73 | 0,78 | 19,3 |
| 280 | 380 | W22Xd 450K/H (1) | 3584 | 5,5 | 0,7 | 2,7 | 36,9 | 18 | 36 | 7200 | 75 | 746 | 94,9 | 95,7 | 95,9 | 0,64 | 0,75 | 0,79 | 21,3 |
| 315 | 425 | W22Xd 450K/H (1) | 4033 | 5,5 | 0,7 | 2,7 | 39,4 | 16 | 32 | 7700 | 75 | 746 | 95,3 | 95,9 | 96,0 | 0,66 | 0,76 | 0,80 | 23,7 |
| 355 | 480 | W22Xd 450K/H (1) | 4545 | 5,5 | 0,7 | 2,7 | 40,2 | 13 | 26 | 7900 | 75 | 746 | 95,5 | 96,1 | 96,1 | 0,66 | 0,76 | 0,80 | 26,7 |
| 400 | 540 | W22Xd 500K/H (1) | 5121 | 5,3 | 0,8 | 2,3 | 113 | 18 | 36 | 11000 | 80 | 746 | 95,8 | 96,5 | 96,5 | 0,73 | 0,80 | 0,80 | 29,9 |
| 450 | 610 | W22Xd 500K/H (1) | 5761 | 5,5 | 0,8 | 2,4 | 118 | 16 | 32 | 11600 | 80 | 746 | 95,8 | 96,5 | 96,5 | 0,72 | 0,79 | 0,80 | 33,7 |
| 500 | 675 | W22Xd 500K/H (1) | 6401 | 5,7 | 0,8 | 2,4 | 132 | 16 | 32 | 12200 | 80 | 746 | 95,8 | 96,5 | 96,5 | 0,72 | 0,79 | 0,80 | 37,4 |
| 500 | 675 | W22Xd 560H/G (1) | 6384 | 5,7 | 0,6 | 3,0 | 155 | 16 | 32 | 12800 | 82 | 748 | 95,8 | 96,5 | 96,5 | 0,66 | 0,76 | 0,80 | 37,4 |
| 560 | 755 | W22Xd 560H/G (1) | 7150 | 5,7 | 0,6 | 3,0 | 163 | 14 | 28 | 13100 | 82 | 748 | 95,8 | 96,5 | 96,6 | 0,66 | 0,76 | 0,80 | 41,8 |

High voltage motors are also available on request for frame size 400.

(1) Copper rotor

T_n = Full load torque
 I_s / I_n = Locked rotor current
 T_s / T_n = Locked rotor torque
 T_{max} / T_n = Breakdown torque
 I_n = Full load current

Notes:
 -The indicated values for sound pressure levels are @ 1m no load, with 3 dB(A) tolerance.
 -All values are according to IEC 60034-1 Standard tolerances.
 -This data can be changed without prior notice.

6.1.3. Medium Voltage - Electrical Data (1100V < U ≤ 6600V)

W22Xd Rib-Cooled Series / Optional - Anti-friction bearings arrangement
Low inrush current ($I_s / I_n \leq 4,5$)

| Output | | Frame IEC | T _n (Nm) | I _s / I _n | T _s / T _n | T _{max} / T _n | Inertia J (Kgm ²) | Allowable locked rotor time Hot/ Cold (s) | Weight (Kg) | Sound Pressure dB(A) | RPM | Y 3000V/50Hz | | | | | | I _n (A) |
|--------|----|-----------|---------------------|---------------------------------|---------------------------------|-----------------------------------|-------------------------------|---|-------------|----------------------|-----|------------------|--|--|--------------------|--|--|--------------------|
| kW | HP | | | | | | | | | | | % of full load | | | | | | |
| | | | | | | | | | | | | Efficiency η (%) | | | Power Factor Cos φ | | | |
| | | 50 | 75 | 100 | 50 | 75 | 100 | | | | | | | | | | | |

II Pole - 3000 min⁻¹

| | | | | | | | | | | | | | | | | | | | |
|-----|------|------------------|------------|-----|-----|-----|------|----|----|------|----|------|------|------|------|------|------|------|------|
| 90 | 120 | W22Xd 355M/L | 288 | 4,5 | 0,9 | 1,9 | 3,3 | 15 | 32 | 2100 | 80 | 2980 | 90,2 | 92,4 | 93,2 | 0,85 | 0,87 | 0,88 | 21,1 |
| 110 | 150 | W22Xd 355M/L | 353 | 4,5 | 0,9 | 1,9 | 3,7 | 15 | 32 | 2200 | 80 | 2980 | 91,4 | 93,3 | 93,9 | 0,85 | 0,87 | 0,88 | 25,6 |
| 132 | 180 | W22Xd 355A/B | 423 | 4,5 | 0,9 | 1,9 | 4,8 | 14 | 31 | 2600 | 80 | 2980 | 92,6 | 94,1 | 94,6 | 0,87 | 0,88 | 0,88 | 30,5 |
| 160 | 215 | W22Xd 355A/B | 513 | 4,5 | 0,9 | 1,9 | 5,1 | 13 | 25 | 2700 | 80 | 2980 | 93,2 | 94,6 | 94,9 | 0,87 | 0,88 | 0,88 | 36,9 |
| 200 | 270 | W22Xd 355A/B | 641 | 4,5 | 0,9 | 1,9 | 5,4 | 13 | 25 | 2850 | 80 | 2980 | 94,0 | 95,1 | 95,3 | 0,87 | 0,88 | 0,88 | 45,9 |
| 250 | 340 | W22Xd 355A/B | 801 | 4,5 | 0,9 | 1,9 | 5,8 | 10 | 20 | 3050 | 80 | 2980 | 94,8 | 95,6 | 95,7 | 0,87 | 0,88 | 0,88 | 57,1 |
| 280 | 380 | W22Xd 400L/J | 897 | 4,5 | 0,9 | 1,8 | 9,9 | 9 | 19 | 4050 | 80 | 2982 | 94,8 | 95,7 | 95,8 | 0,84 | 0,86 | 0,86 | 65,4 |
| 315 | 425 | W22Xd 400L/J | 1009 | 4,5 | 0,9 | 1,8 | 10,2 | 8 | 17 | 4100 | 80 | 2982 | 95,0 | 95,8 | 96,0 | 0,84 | 0,86 | 0,86 | 73 |
| 355 | 480 | W22Xd 400L/J | 1137 | 4,5 | 0,9 | 1,8 | 10,8 | 8 | 16 | 4200 | 80 | 2982 | 95,3 | 96,0 | 96,2 | 0,84 | 0,86 | 0,86 | 83 |
| 400 | 540 | W22Xd 400G | 1281 | 4,5 | 0,9 | 1,8 | 12,5 | 8 | 16 | 5200 | 80 | 2982 | 95,4 | 96,1 | 96,3 | 0,84 | 0,86 | 0,86 | 93 |
| 450 | 610 | W22Xd 400G (1) | 1439 | 4,5 | 0,8 | 1,8 | 13,5 | 7 | 18 | 5400 | 80 | 2986 | 96,2 | 96,6 | 96,6 | 0,87 | 0,88 | 0,88 | 102 |
| 500 | 675 | W22Xd 450K/H (1) | 1599 | 4,5 | 0,7 | 1,7 | 14,3 | 8 | 22 | 6400 | 80 | 2986 | 95,9 | 96,6 | 96,7 | 0,86 | 0,88 | 0,88 | 113 |
| 560 | 755 | W22Xd 450K/H (1) | 1791 | 4,5 | 0,7 | 1,7 | 15,2 | 7 | 20 | 6650 | 80 | 2986 | 96 | 96,7 | 96,8 | 0,86 | 0,88 | 0,88 | 127 |
| 630 | 850 | W22Xd 500K/H (1) | 2014 | 4,5 | 0,9 | 1,8 | 21,7 | 10 | 18 | 9000 | 85 | 2987 | 96,1 | 96,5 | 96,9 | 0,87 | 0,89 | 0,89 | 141 |
| 710 | 960 | W22Xd 500K/H (1) | 2270 | 4,5 | 0,9 | 1,8 | 23,2 | 9 | 17 | 9200 | 85 | 2987 | 96,2 | 96,6 | 97,0 | 0,87 | 0,89 | 0,89 | 158 |
| 800 | 1080 | W22Xd 500K/H (1) | 2558 | 4,5 | 0,9 | 1,8 | 24,7 | 7 | 16 | 9650 | 85 | 2987 | 96,3 | 96,7 | 97,1 | 0,87 | 0,89 | 0,89 | 178 |
| 800 | 1080 | W22Xd 560H/G (1) | On request | | | | | | | | | | | | | | | | |
| 900 | 1215 | W22Xd 560H/G (1) | On request | | | | | | | | | | | | | | | | |

IV Pole - 1500 min⁻¹

| | | | | | | | | | | | | | | | | | | | |
|------|------|------------------|------|-----|-----|-----|------|----|----|-------|----|------|------|------|------|------|------|------|------|
| 90 | 120 | W22Xd 355M/L | 579 | 4,5 | 0,9 | 1,7 | 5,4 | 18 | 39 | 2200 | 76 | 1485 | 91,3 | 92,9 | 93,5 | 0,77 | 0,82 | 0,84 | 22,1 |
| 110 | 150 | W22Xd 355M/L | 707 | 4,5 | 0,9 | 1,7 | 6,3 | 16 | 34 | 2300 | 76 | 1485 | 91,6 | 93,2 | 93,8 | 0,77 | 0,82 | 0,84 | 26,9 |
| 132 | 180 | W22Xd 355A/B | 849 | 4,5 | 0,9 | 1,7 | 7,3 | 16 | 34 | 2775 | 76 | 1485 | 93,3 | 94,3 | 94,4 | 0,79 | 0,83 | 0,84 | 32,1 |
| 160 | 215 | W22Xd 355A/B | 1029 | 4,5 | 0,9 | 1,7 | 7,5 | 14 | 32 | 2900 | 76 | 1485 | 93,8 | 94,6 | 94,7 | 0,79 | 0,82 | 0,84 | 38,7 |
| 200 | 270 | W22Xd 355A/B | 1286 | 4,5 | 0,9 | 1,7 | 8,2 | 12 | 28 | 3050 | 76 | 1485 | 94,5 | 95,1 | 95,2 | 0,80 | 0,82 | 0,84 | 48,1 |
| 250 | 340 | W22Xd 355A/B | 1608 | 4,5 | 0,9 | 1,7 | 8,7 | 10 | 25 | 3250 | 76 | 1485 | 95,2 | 95,6 | 95,7 | 0,80 | 0,84 | 0,84 | 59,9 |
| 280 | 380 | W22Xd 400L/J | 1793 | 4,5 | 0,8 | 1,9 | 19,1 | 14 | 35 | 4200 | 80 | 1491 | 94,3 | 95,3 | 95,8 | 0,80 | 0,85 | 0,85 | 66,2 |
| 315 | 425 | W22Xd 400L/J | 2018 | 4,5 | 0,8 | 1,9 | 20,1 | 13 | 32 | 4350 | 80 | 1491 | 94,6 | 95,4 | 95,9 | 0,80 | 0,85 | 0,85 | 74,4 |
| 355 | 480 | W22Xd 400L/J | 2274 | 4,5 | 0,8 | 1,9 | 21,3 | 12 | 29 | 4550 | 80 | 1491 | 94,9 | 95,8 | 96,0 | 0,81 | 0,85 | 0,85 | 83,7 |
| 400 | 540 | W22Xd 400G (1) | 2569 | 4,5 | 0,5 | 1,9 | 25,9 | 16 | 36 | 5350 | 80 | 1487 | 96,0 | 96,2 | 96,3 | 0,83 | 0,87 | 0,87 | 91,9 |
| 450 | 610 | W22Xd 400G (1) | 2890 | 4,5 | 0,5 | 1,9 | 27,1 | 16 | 36 | 5540 | 80 | 1487 | 96,0 | 96,3 | 96,4 | 0,83 | 0,87 | 0,87 | 103 |
| 500 | 675 | W22Xd 400G (1) | 3211 | 4,5 | 0,5 | 1,9 | 27,6 | 14 | 32 | 5600 | 80 | 1487 | 96,1 | 96,4 | 96,5 | 0,83 | 0,87 | 0,87 | 115 |
| 560 | 755 | W22Xd 450K/H (1) | 3582 | 4,5 | 0,5 | 1,9 | 28,2 | 14 | 28 | 6700 | 80 | 1493 | 96,3 | 96,7 | 96,7 | 0,75 | 0,82 | 0,84 | 133 |
| 630 | 850 | W22Xd 450K/H (1) | 4030 | 4,5 | 0,5 | 1,9 | 29,6 | 12 | 24 | 7000 | 80 | 1493 | 96,4 | 96,8 | 96,8 | 0,75 | 0,82 | 0,84 | 149 |
| 710 | 960 | W22Xd 500K/H (1) | 4535 | 4,5 | 0,4 | 1,8 | 61,1 | 16 | 36 | 10000 | 80 | 1495 | 96,5 | 97,1 | 97,1 | 0,82 | 0,86 | 0,86 | 164 |
| 800 | 1080 | W22Xd 500K/H (1) | 5110 | 4,5 | 0,4 | 1,8 | 65,0 | 15 | 32 | 10250 | 80 | 1495 | 96,7 | 97,2 | 97,2 | 0,82 | 0,86 | 0,86 | 184 |
| 900 | 1215 | W22Xd 500K/H (1) | 5749 | 4,5 | 0,4 | 1,8 | 69,4 | 14 | 29 | 10500 | 80 | 1495 | 96,7 | 97,3 | 97,3 | 0,82 | 0,86 | 0,86 | 207 |
| 1000 | 1350 | W22Xd 500K/H (1) | 6388 | 4,5 | 0,4 | 1,8 | 72,2 | 13 | 26 | 11000 | 80 | 1495 | 96,9 | 97,4 | 97,4 | 0,82 | 0,86 | 0,86 | 230 |
| 1120 | 1515 | W22Xd 500K/H (1) | 7155 | 4,5 | 0,4 | 1,8 | 75,0 | 12 | 23 | 11200 | 80 | 1495 | 97,1 | 97,5 | 97,5 | 0,82 | 0,86 | 0,86 | 257 |
| 1120 | 1515 | W22Xd 560H/G (1) | 7150 | 4,5 | 0,4 | 2,0 | 98,3 | 16 | 31 | 12360 | 86 | 1496 | 97,1 | 97,5 | 97,5 | 0,84 | 0,87 | 0,87 | 254 |
| 1250 | 1690 | W22Xd 560H/G (1) | 7980 | 4,5 | 0,4 | 2,0 | 103 | 15 | 28 | 12720 | 86 | 1496 | 97,2 | 97,5 | 97,6 | 0,84 | 0,87 | 0,87 | 283 |

W22Xd Rib-Cooled Series / Optional - Anti-friction bearings arrangement
Low inrush current ($I_s / I_n \leq 4,5$)

| Output | | Frame IEC | T_n (Nm) | I_s / I_n | T_s / T_n | T_{max} / T_n | Inertia J (Kgm ²) | Allowable locked rotor time Hot/Cold (s) | Weight (Kg) | Sound Pressure dB(A) | RPM | Y 3000V/50Hz | | | | | | |
|--------|----|-----------|------------|-------------|-------------|-----------------|-------------------------------|--|-------------|----------------------|-----|-----------------------|--|--|----------------------------|--|--|-----------|
| kW | HP | | | | | | | | | | | % of full load | | | | | | I_n (A) |
| | | | | | | | | | | | | Efficiency η (%) | | | Power Factor Cos φ | | | |
| | | 50 | 75 | 100 | 50 | 75 | 100 | | | | | | | | | | | |

VI Pole - 1000 min⁻¹

| | | | | | | | | | | | | | | | | | | | |
|-----|------|------------------|------|-----|-----|-----|------|----|----|-------|----|-----|------|------|------|------|------|------|------|
| 110 | 150 | W22Xd 355A/B | 1061 | 4,5 | 0,9 | 1,6 | 9,3 | 19 | 40 | 2600 | 69 | 990 | 93,8 | 94,0 | 94,5 | 0,65 | 0,75 | 0,80 | 28,0 |
| 132 | 180 | W22Xd 355A/B | 1273 | 4,5 | 0,9 | 1,6 | 10,0 | 19 | 40 | 2700 | 69 | 990 | 94,0 | 94,3 | 94,8 | 0,65 | 0,75 | 0,80 | 33,5 |
| 160 | 215 | W22Xd 355A/B | 1543 | 4,5 | 0,9 | 1,6 | 10,8 | 17 | 36 | 2850 | 69 | 990 | 94,2 | 94,7 | 95,2 | 0,65 | 0,75 | 0,80 | 40,4 |
| 200 | 270 | W22Xd 355A/B | 1929 | 4,5 | 0,9 | 1,6 | 11,6 | 17 | 36 | 3050 | 69 | 990 | 94,5 | 95,0 | 95,5 | 0,66 | 0,75 | 0,80 | 50,4 |
| 250 | 340 | W22Xd 400L/J | 2412 | 4,5 | 0,6 | 1,6 | 22,9 | 16 | 35 | 4200 | 75 | 990 | 95,7 | 95,9 | 96,0 | 0,75 | 0,80 | 0,80 | 85,3 |
| 280 | 380 | W22Xd 400L/J | 2701 | 4,5 | 0,6 | 1,6 | 24,5 | 15 | 32 | 4400 | 75 | 990 | 95,7 | 95,9 | 96,0 | 0,75 | 0,80 | 0,80 | 70,2 |
| 315 | 425 | W22Xd 400G (1) | 3036 | 4,5 | 0,5 | 1,5 | 28,0 | 18 | 37 | 4800 | 75 | 991 | 95,6 | 95,9 | 96,0 | 0,81 | 0,82 | 0,83 | 76,1 |
| 355 | 480 | W22Xd 400G (1) | 3421 | 4,5 | 0,5 | 1,5 | 32,0 | 18 | 37 | 4850 | 75 | 991 | 95,8 | 96,0 | 96,1 | 0,80 | 0,82 | 0,83 | 85,7 |
| 400 | 540 | W22Xd 400G (1) | 3855 | 4,5 | 0,5 | 1,5 | 33,5 | 16 | 33 | 4900 | 75 | 991 | 95,9 | 96,1 | 96,1 | 0,80 | 0,82 | 0,83 | 96,5 |
| 450 | 610 | W22Xd 450K/H (1) | 4323 | 4,5 | 0,5 | 2,0 | 52,1 | 20 | 40 | 6600 | 76 | 994 | 95,8 | 96,3 | 96,3 | 0,78 | 0,83 | 0,85 | 106 |
| 500 | 675 | W22Xd 450K/H (1) | 4804 | 4,5 | 0,5 | 2,0 | 54,7 | 18 | 38 | 6800 | 76 | 994 | 96,0 | 96,5 | 96,5 | 0,79 | 0,84 | 0,85 | 117 |
| 560 | 755 | W22Xd 500K/H (1) | 5364 | 4,5 | 0,4 | 2,0 | 93,5 | 19 | 37 | 10400 | 80 | 997 | 96,4 | 96,7 | 96,7 | 0,75 | 0,83 | 0,85 | 131 |
| 630 | 850 | W22Xd 500K/H (1) | 6035 | 4,5 | 0,4 | 2,0 | 105 | 19 | 36 | 10650 | 80 | 997 | 96,6 | 96,9 | 96,9 | 0,75 | 0,83 | 0,85 | 147 |
| 710 | 960 | W22Xd 500K/H (1) | 6801 | 4,5 | 0,4 | 2,0 | 108 | 18 | 34 | 11100 | 80 | 997 | 96,7 | 97,0 | 97,0 | 0,75 | 0,83 | 0,85 | 166 |
| 800 | 1080 | W22Xd 500K/H (1) | 7663 | 4,5 | 0,4 | 2,0 | 110 | 16 | 31 | 11500 | 80 | 997 | 96,7 | 97,0 | 97,0 | 0,75 | 0,83 | 0,85 | 187 |
| 800 | 1080 | W22Xd 560H/G (1) | 7671 | 4,5 | 0,4 | 1,9 | 164 | 18 | 37 | 12600 | 82 | 996 | 96,7 | 97,0 | 97,0 | 0,78 | 0,84 | 0,85 | 187 |
| 900 | 1215 | W22Xd 560H/G (1) | 8630 | 4,5 | 0,4 | 1,9 | 171 | 15 | 32 | 12960 | 82 | 996 | 96,8 | 97,0 | 97,1 | 0,78 | 0,84 | 0,85 | 210 |

VIII Pole - 750 min⁻¹

| | | | | | | | | | | | | | | | | | | | |
|-----|------|------------------|-------|-----|-----|-----|------|----|----|-------|----|-----|------|------|------|------|------|------|------|
| 132 | 180 | W22Xd 400L/J (1) | 1704 | 4,5 | 0,4 | 1,6 | 35,2 | 18 | 40 | 4000 | 74 | 740 | 94,0 | 95,5 | 96,0 | 0,75 | 0,80 | 0,81 | 32,7 |
| 160 | 215 | W22Xd 400L/J (1) | 2065 | 4,5 | 0,4 | 1,6 | 36,9 | 18 | 40 | 4200 | 74 | 740 | 94,3 | 95,8 | 96,0 | 0,75 | 0,80 | 0,81 | 39,6 |
| 200 | 270 | W22Xd 400L/J (1) | 2581 | 4,5 | 0,4 | 1,6 | 38,1 | 18 | 40 | 4400 | 74 | 740 | 94,3 | 95,8 | 96,1 | 0,75 | 0,80 | 0,81 | 49,4 |
| 250 | 340 | W22Xd 400G (1) | 3226 | 4,5 | 0,4 | 1,6 | 41,5 | 17 | 37 | 5050 | 74 | 740 | 94,9 | 95,8 | 96,2 | 0,75 | 0,80 | 0,81 | 61,7 |
| 280 | 380 | W22Xd 400G (1) | 3614 | 4,5 | 0,4 | 1,6 | 43,5 | 17 | 37 | 5150 | 74 | 740 | 94,9 | 95,8 | 96,2 | 0,75 | 0,80 | 0,81 | 69,2 |
| 315 | 425 | W22Xd 400G (1) | 4065 | 4,5 | 0,4 | 1,6 | 45,6 | 17 | 37 | 5200 | 74 | 740 | 94,9 | 95,8 | 96,2 | 0,75 | 0,80 | 0,81 | 77,8 |
| 355 | 480 | W22Xd 450K/H (1) | 4557 | 4,5 | 0,4 | 1,8 | 53,8 | 17 | 32 | 6400 | 75 | 744 | 96,0 | 96,3 | 96,3 | 0,75 | 0,81 | 0,81 | 87,6 |
| 400 | 540 | W22Xd 450K/H (1) | 5134 | 4,5 | 0,4 | 1,8 | 56,5 | 15 | 29 | 6700 | 75 | 744 | 96,0 | 96,3 | 96,3 | 0,75 | 0,81 | 0,81 | 98,7 |
| 450 | 610 | W22Xd 450K/H (1) | 5776 | 4,5 | 0,4 | 1,8 | 57,5 | 15 | 29 | 7000 | 75 | 744 | 96,0 | 96,3 | 96,3 | 0,75 | 0,81 | 0,81 | 111 |
| 500 | 675 | W22Xd 500K/H (1) | 6401 | 4,5 | 0,4 | 1,8 | 133 | 18 | 37 | 10500 | 80 | 746 | 96,8 | 96,8 | 96,8 | 0,75 | 0,81 | 0,81 | 123 |
| 560 | 755 | W22Xd 500K/H (1) | 7169 | 4,5 | 0,4 | 1,8 | 136 | 18 | 35 | 10600 | 80 | 746 | 96,9 | 96,9 | 96,9 | 0,74 | 0,81 | 0,81 | 137 |
| 630 | 850 | W22Xd 500K/H (1) | 8065 | 4,5 | 0,4 | 1,8 | 147 | 17 | 34 | 11200 | 80 | 746 | 96,9 | 97,0 | 97,0 | 0,73 | 0,80 | 0,80 | 156 |
| 710 | 960 | W22Xd 500K/H (1) | 9089 | 4,5 | 0,4 | 1,8 | 148 | 17 | 32 | 11800 | 80 | 746 | 96,9 | 97,1 | 97,1 | 0,73 | 0,80 | 0,80 | 176 |
| 710 | 960 | W22Xd 560H/G (1) | 9077 | 4,5 | 0,4 | 2,4 | 186 | 18 | 37 | 13540 | 82 | 747 | 96,9 | 97,2 | 97,2 | 0,70 | 0,78 | 0,79 | 178 |
| 800 | 1080 | W22Xd 560H/G (1) | 10228 | 4,5 | 0,4 | 2,4 | 188 | 15 | 32 | 13680 | 82 | 747 | 96,9 | 97,4 | 97,4 | 0,70 | 0,78 | 0,79 | 200 |

(1) Copper rotor

T_n = Full load torque

I_s / I_n = Locked rotor current

T_s / T_n = Locked rotor torque

T_{max} / T_n = Breakdown torque

I_n = Full load current

Notes:

-The indicated values for sound pressure levels are @ 1m no load, with 3 dB(A) tolerance.

-All values are according to IEC 60034-1 Standard tolerances.

-This data can be changed without prior notice.

W22Xd Rib-Cooled Series / Optional - Anti-friction bearings arrangement
Low inrush current ($I_S / I_n \leq 4,5$)

| Output | | Frame IEC | T_n (Nm) | I_S / I_n | T_S / T_n | T_{max} / T_n | Inertia J (Kgm ²) | Allowable locked rotor time Hot/Cold (s) | Weight (Kg) | Sound Pressure dB(A) | RPM | Y 4160V/60Hz | | | | | | I_n (A) | |
|--|------|------------------|------------|-------------|-------------|-----------------|-------------------------------|--|-------------|----------------------|-----|-----------------------|------|------|-------------------------|------|------|-----------|------|
| kW | HP | | | | | | | | | | | % of full load | | | | | | | |
| | | | | | | | | | | | | Efficiency η (%) | | | Power Factor Cos ϕ | | | | |
| | | | | 50 | 75 | 100 | 50 | 75 | 100 | | | | | | | | | | |
| II Pole - 3600 min⁻¹ | | | | | | | | | | | | | | | | | | | |
| 90 | 120 | W22Xd 355M/L | 240 | 4,5 | 0,8 | 1,9 | 2,9 | 15 | 33 | 2000 | 85 | 3585 | 87,7 | 90,7 | 91,7 | 0,84 | 0,86 | 0,87 | 15,7 |
| 110 | 150 | W22Xd 355M/L | 293 | 4,5 | 0,8 | 1,9 | 3,3 | 15 | 33 | 2100 | 85 | 3585 | 89,5 | 92,0 | 92,8 | 0,84 | 0,86 | 0,87 | 18,9 |
| 132 | 180 | W22Xd 355M/L | 352 | 4,5 | 0,8 | 1,9 | 4,3 | 14 | 32 | 2300 | 85 | 3585 | 91,2 | 93,1 | 93,8 | 0,85 | 0,87 | 0,88 | 22,2 |
| 160 | 215 | W22Xd 355A/B | 426 | 4,5 | 0,9 | 1,9 | 4,8 | 14 | 32 | 2600 | 85 | 3585 | 92,1 | 93,8 | 94,2 | 0,87 | 0,88 | 0,88 | 26,8 |
| 200 | 270 | W22Xd 355A/B | 533 | 4,5 | 0,9 | 1,9 | 5,1 | 11 | 24 | 2700 | 85 | 3585 | 93,3 | 94,6 | 94,8 | 0,87 | 0,88 | 0,88 | 33,3 |
| 250 | 340 | W22Xd 355A/B | 666 | 4,5 | 0,9 | 1,9 | 5,4 | 9 | 19 | 2850 | 85 | 3585 | 94,2 | 95,2 | 95,3 | 0,87 | 0,88 | 0,88 | 41,4 |
| 280 | 380 | W22Xd 355A/B | 746 | 4,5 | 0,9 | 1,9 | 5,8 | 9 | 19 | 3050 | 85 | 3585 | 94,1 | 95,2 | 95,4 | 0,87 | 0,88 | 0,88 | 46,3 |
| 315 | 425 | W22Xd 400L/J | 839 | 4,5 | 0,9 | 1,7 | 9,9 | 8 | 19 | 4050 | 85 | 3585 | 93,9 | 95,1 | 95,5 | 0,83 | 0,86 | 0,86 | 53,2 |
| 355 | 480 | W22Xd 400L/J | 946 | 4,5 | 0,9 | 1,7 | 10,2 | 8 | 18 | 4100 | 85 | 3585 | 94,3 | 95,4 | 95,6 | 0,83 | 0,86 | 0,86 | 59,9 |
| 400 | 540 | W22Xd 400G | 1066 | 4,5 | 0,9 | 1,7 | 11,5 | 6 | 15 | 4900 | 85 | 3585 | 94,4 | 95,4 | 95,8 | 0,83 | 0,86 | 0,86 | 67,4 |
| 450 | 610 | W22Xd 400G | 1199 | 4,5 | 0,9 | 1,7 | 12,5 | 6 | 15 | 5200 | 85 | 3585 | 94,4 | 95,4 | 95,8 | 0,83 | 0,86 | 0,86 | 75,8 |
| 500 | 675 | W22Xd 400G (1) | 1330 | 4,5 | 0,8 | 1,7 | 13,5 | 6 | 15 | 5400 | 85 | 3590 | 94,9 | 95,8 | 95,9 | 0,86 | 0,87 | 0,87 | 83,2 |
| 560 | 755 | W22Xd 450K/H (1) | 1489 | 4,5 | 0,7 | 1,7 | 14,3 | 9 | 28 | 6400 | 85 | 3591 | 95,2 | 95,6 | 96,1 | 0,86 | 0,88 | 0,88 | 91,9 |
| 630 | 850 | W22Xd 450K/H (1) | 1675 | 4,5 | 0,7 | 1,7 | 15,2 | 8 | 25 | 6650 | 85 | 3591 | 95,2 | 95,6 | 96,1 | 0,86 | 0,88 | 0,88 | 103 |
| 710 | 960 | W22Xd 500K/H (1) | On request | | | | | | | | | | | | | | | | |
| 800 | 1080 | W22Xd 500K/H (1) | | | | | | | | | | | | | | | | | |
| 800 | 1080 | W22Xd 560H/G (1) | | | | | | | | | | | | | | | | | |
| 900 | 1215 | W22Xd 560H/G (1) | | | | | | | | | | | | | | | | | |
| IV Pole - 1800 min⁻¹ | | | | | | | | | | | | | | | | | | | |
| 90 | 120 | W22Xd 355M/L | 480 | 4,5 | 0,8 | 1,6 | 4,8 | 18 | 39 | 2100 | 81 | 1791 | 88,3 | 91,2 | 92,4 | 0,74 | 0,81 | 0,84 | 16,1 |
| 110 | 150 | W22Xd 355M/L | 587 | 4,5 | 0,8 | 1,6 | 5,4 | 16 | 34 | 2200 | 81 | 1791 | 88,7 | 91,6 | 92,9 | 0,74 | 0,81 | 0,84 | 19,6 |
| 132 | 180 | W22Xd 355A/B | 704 | 4,5 | 0,8 | 1,6 | 6,3 | 16 | 33 | 2300 | 81 | 1791 | 92,3 | 93,9 | 94,1 | 0,80 | 0,82 | 0,85 | 22,9 |
| 160 | 215 | W22Xd 355A/B | 853 | 4,5 | 0,8 | 1,6 | 7,3 | 15 | 31 | 2775 | 81 | 1791 | 92,5 | 94,0 | 94,3 | 0,80 | 0,82 | 0,85 | 27,7 |
| 200 | 270 | W22Xd 355A/B | 1066 | 4,5 | 0,8 | 1,6 | 7,5 | 15 | 31 | 2900 | 81 | 1791 | 93,5 | 94,5 | 94,8 | 0,81 | 0,84 | 0,85 | 34,4 |
| 250 | 340 | W22Xd 355A/B | 1333 | 4,5 | 0,8 | 1,6 | 8,2 | 12 | 25 | 3050 | 81 | 1791 | 94,3 | 95,1 | 95,4 | 0,83 | 0,85 | 0,85 | 42,8 |
| 280 | 380 | W22Xd 355A/B | 1493 | 4,5 | 0,8 | 1,6 | 8,7 | 12 | 25 | 3250 | 81 | 1791 | 94,3 | 95,1 | 95,4 | 0,83 | 0,85 | 0,85 | 47,9 |
| 315 | 425 | W22Xd 400L/J | 1679 | 4,5 | 0,7 | 1,9 | 19,1 | 15 | 32 | 4200 | 85 | 1792 | 94,3 | 95,2 | 95,5 | 0,82 | 0,85 | 0,85 | 53,9 |
| 355 | 480 | W22Xd 400L/J | 1892 | 4,5 | 0,7 | 1,9 | 20,1 | 14 | 29 | 4350 | 85 | 1792 | 94,3 | 95,3 | 95,6 | 0,82 | 0,85 | 0,85 | 60,6 |
| 400 | 540 | W22Xd 400G (1) | 2132 | 4,5 | 0,5 | 1,9 | 23,2 | 20 | 40 | 5150 | 85 | 1792 | 94,4 | 95,3 | 95,6 | 0,82 | 0,85 | 0,86 | 67,5 |
| 450 | 610 | W22Xd 400G (1) | 2398 | 4,5 | 0,5 | 1,9 | 25,9 | 17 | 34 | 5350 | 85 | 1792 | 94,5 | 95,4 | 95,7 | 0,82 | 0,86 | 0,86 | 75,9 |
| 500 | 675 | W22Xd 400G (1) | 2665 | 4,5 | 0,5 | 1,9 | 27,1 | 15 | 30 | 5540 | 85 | 1792 | 94,5 | 95,5 | 95,7 | 0,82 | 0,86 | 0,86 | 84,3 |
| 560 | 755 | W22Xd 400G (1) | 2984 | 4,5 | 0,5 | 1,9 | 27,6 | 12 | 23 | 5600 | 85 | 1792 | 94,6 | 95,6 | 95,8 | 0,82 | 0,86 | 0,86 | 94,3 |
| 630 | 850 | W22Xd 450K/H (1) | 3354 | 4,5 | 0,5 | 1,9 | 28,2 | 17 | 34 | 6700 | 85 | 1794 | 95,5 | 96,3 | 96,3 | 0,76 | 0,82 | 0,84 | 108 |
| 710 | 960 | W22Xd 450K/H (1) | 3780 | 4,5 | 0,5 | 1,9 | 29,6 | 15 | 30 | 7000 | 85 | 1794 | 95,6 | 96,4 | 96,4 | 0,76 | 0,82 | 0,84 | 122 |
| 800 | 1080 | W22Xd 500K/H (1) | 4254 | 4,5 | 0,4 | 1,8 | 61,1 | 14 | 29 | 10000 | 85 | 1796 | 95,1 | 96,3 | 96,6 | 0,81 | 0,86 | 0,86 | 134 |
| 900 | 1215 | W22Xd 500K/H (1) | 4786 | 4,5 | 0,4 | 1,8 | 65,0 | 14 | 29 | 10250 | 85 | 1796 | 95,2 | 96,3 | 96,6 | 0,81 | 0,86 | 0,86 | 150 |
| 1000 | 1350 | W22Xd 500K/H (1) | 5317 | 4,5 | 0,4 | 1,8 | 69,4 | 13 | 27 | 10500 | 85 | 1796 | 95,1 | 96,3 | 96,6 | 0,81 | 0,86 | 0,86 | 167 |
| 1120 | 1515 | W22Xd 500K/H (1) | 5955 | 4,5 | 0,4 | 1,8 | 72,2 | 12 | 24 | 11000 | 85 | 1796 | 95,3 | 96,4 | 96,7 | 0,81 | 0,86 | 0,86 | 187 |
| 1120 | 1515 | W22Xd 560H/G (1) | 5955 | 4,5 | 0,4 | 2,0 | 98,3 | 14 | 28 | 12360 | 91 | 1796 | 96,0 | 96,6 | 96,8 | 0,83 | 0,88 | 0,87 | 185 |
| 1250 | 1690 | W22Xd 560H/G (1) | 6647 | 4,5 | 0,4 | 2,0 | 103 | 12 | 24 | 12720 | 91 | 1796 | 96,4 | 96,8 | 96,9 | 0,83 | 0,88 | 0,87 | 206 |

W22Xd Rib-Cooled Series / Optional - Anti-friction bearings arrangement
Low inrush current ($I_S / I_n \leq 4,5$)

| Output | | Frame IEC | T_n (Nm) | I_S / I_n | T_S / T_n | T_{max} / T_n | Inertia J (Kgm ²) | Allowable locked rotor time Hot/Cold (s) | Weight (Kg) | Sound Pressure dB(A) | RPM | Y 4160V/60Hz | | | | | | I_n (A) | |
|---|------|------------------|------------|-------------|-------------|-----------------|-------------------------------|--|-------------|----------------------|-----|-----------------------|------|------|-------------------------|------|------|-----------|------|
| kW | HP | | | | | | | | | | | % of full load | | | | | | | |
| | | | | | | | | | | | | Efficiency η (%) | | | Power Factor Cos ϕ | | | | |
| | | 50 | 75 | 100 | 50 | 75 | 100 | | | | | | | | | | | | |
| VI Pole - 1200 min⁻¹ | | | | | | | | | | | | | | | | | | | |
| 110 | 150 | W22Xd 355A/B | 881 | 4,5 | 0,8 | 1,5 | 7,4 | 15 | 38 | 2500 | 74 | 1193 | 93,1 | 93,7 | 94,2 | 0,65 | 0,75 | 0,80 | 20,3 |
| 132 | 180 | W22Xd 355A/B | 1057 | 4,5 | 0,8 | 1,5 | 9,3 | 15 | 37 | 2600 | 74 | 1193 | 93,4 | 94,0 | 94,5 | 0,65 | 0,75 | 0,80 | 24,2 |
| 160 | 215 | W22Xd 355A/B | 1281 | 4,5 | 0,9 | 1,5 | 10,0 | 14 | 36 | 2700 | 74 | 1193 | 93,4 | 94,2 | 94,8 | 0,65 | 0,75 | 0,80 | 29,3 |
| 200 | 270 | W22Xd 355A/B | 1601 | 4,5 | 0,9 | 1,5 | 10,8 | 14 | 36 | 2850 | 74 | 1193 | 93,6 | 94,4 | 94,9 | 0,65 | 0,75 | 0,80 | 36,6 |
| 250 | 340 | W22Xd 355A/B | 2001 | 4,5 | 0,9 | 1,5 | 11,6 | 12 | 30 | 3050 | 74 | 1193 | 94,5 | 95,0 | 95,0 | 0,65 | 0,75 | 0,80 | 45,7 |
| 280 | 380 | W22Xd 400L/J | 2245 | 4,5 | 0,6 | 1,6 | 22,9 | 19 | 40 | 4200 | 80 | 1191 | 95,1 | 95,4 | 95,4 | 0,80 | 0,81 | 0,81 | 50,3 |
| 315 | 425 | W22Xd 400G (1) | 2526 | 4,5 | 0,5 | 1,5 | 25,3 | 19 | 37 | 4550 | 80 | 1191 | 95,2 | 95,4 | 95,5 | 0,80 | 0,82 | 0,83 | 55,2 |
| 355 | 480 | W22Xd 400G (1) | 2847 | 4,5 | 0,5 | 1,5 | 28,0 | 17 | 35 | 4800 | 80 | 1191 | 95,2 | 95,4 | 95,6 | 0,80 | 0,82 | 0,83 | 62,1 |
| 400 | 540 | W22Xd 400G (1) | 3207 | 4,5 | 0,5 | 1,5 | 32,0 | 16 | 34 | 4850 | 80 | 1191 | 95,3 | 95,8 | 95,8 | 0,80 | 0,82 | 0,83 | 69,8 |
| 450 | 610 | W22Xd 400G (1) | 3608 | 4,5 | 0,5 | 1,5 | 33,5 | 15 | 32 | 4900 | 80 | 1191 | 95,4 | 95,8 | 95,8 | 0,81 | 0,83 | 0,83 | 78,5 |
| 500 | 675 | W22Xd 450K/H (1) | 3996 | 4,5 | 0,5 | 2,0 | 52,1 | 17 | 35 | 6600 | 81 | 1195 | 94,7 | 95,5 | 96,0 | 0,79 | 0,84 | 0,85 | 85,0 |
| 560 | 755 | W22Xd 450K/H (1) | 4475 | 4,5 | 0,5 | 2,0 | 54,7 | 15 | 32 | 6800 | 81 | 1195 | 94,7 | 95,5 | 96,0 | 0,79 | 0,84 | 0,85 | 95,2 |
| 630 | 850 | W22Xd 500K/H (1) | 5031 | 4,5 | 0,4 | 2,0 | 93,5 | 19 | 34 | 10400 | 85 | 1196 | 95,8 | 96,3 | 96,3 | 0,75 | 0,83 | 0,85 | 107 |
| 710 | 960 | W22Xd 500K/H (1) | 5669 | 4,5 | 0,4 | 2,0 | 105 | 19 | 34 | 10650 | 85 | 1196 | 95,9 | 96,4 | 96,4 | 0,76 | 0,83 | 0,85 | 120 |
| 800 | 1080 | W22Xd 500K/H (1) | 6388 | 4,5 | 0,4 | 2,0 | 108 | 17 | 28 | 11100 | 85 | 1196 | 96,0 | 96,4 | 96,4 | 0,77 | 0,83 | 0,85 | 136 |
| 800 | 1080 | W22Xd 560H/G (1) | 6388 | 4,5 | 0,4 | 1,9 | 164 | 15 | 27 | 12600 | 87 | 1196 | 96,0 | 96,4 | 96,4 | 0,77 | 0,84 | 0,85 | 136 |
| 900 | 1215 | W22Xd 560H/G (1) | 7186 | 4,5 | 0,4 | 1,9 | 171 | 14 | 25 | 12960 | 87 | 1196 | 96,0 | 96,4 | 96,5 | 0,77 | 0,84 | 0,85 | 152 |
| VIII Pole - 900 min⁻¹ | | | | | | | | | | | | | | | | | | | |
| 132 | 180 | W22Xd 400L/J (1) | 1416 | 4,5 | 0,4 | 1,6 | 31,7 | 18 | 40 | 3850 | 79 | 890 | 93,8 | 95,6 | 95,6 | 0,75 | 0,80 | 0,81 | 23,7 |
| 160 | 215 | W22Xd 400L/J (1) | 1717 | 4,5 | 0,4 | 1,6 | 35,2 | 18 | 40 | 4000 | 79 | 890 | 94,1 | 95,7 | 95,7 | 0,75 | 0,80 | 0,81 | 28,6 |
| 200 | 270 | W22Xd 400L/J (1) | 2146 | 4,5 | 0,4 | 1,6 | 36,9 | 18 | 40 | 4200 | 79 | 890 | 94,2 | 95,7 | 95,7 | 0,75 | 0,80 | 0,81 | 35,8 |
| 250 | 340 | W22Xd 400G (1) | 2683 | 4,5 | 0,4 | 1,6 | 38,1 | 17 | 38 | 4400 | 79 | 890 | 94,3 | 95,7 | 95,8 | 0,75 | 0,80 | 0,81 | 44,7 |
| 280 | 380 | W22Xd 400G (1) | 3004 | 4,5 | 0,4 | 1,6 | 39,2 | 17 | 38 | 4750 | 79 | 890 | 94,4 | 95,8 | 95,8 | 0,75 | 0,80 | 0,81 | 50,1 |
| 315 | 425 | W22Xd 400G (1) | 3380 | 4,5 | 0,4 | 1,6 | 41,5 | 17 | 38 | 5050 | 79 | 890 | 94,4 | 95,7 | 95,9 | 0,75 | 0,80 | 0,81 | 56,3 |
| 355 | 480 | W22Xd 400G (1) | 3809 | 4,5 | 0,4 | 1,6 | 43,5 | 17 | 38 | 5150 | 79 | 890 | 94,7 | 95,9 | 95,9 | 0,75 | 0,81 | 0,81 | 63,4 |
| 400 | 540 | W22Xd 450K/H (1) | 4292 | 4,5 | 0,4 | 1,8 | 53,8 | 18 | 40 | 6400 | 80 | 890 | 95,7 | 96,0 | 96,0 | 0,75 | 0,81 | 0,81 | 71,4 |
| 450 | 610 | W22Xd 450K/H (1) | 4829 | 4,5 | 0,4 | 1,8 | 56,5 | 18 | 40 | 6700 | 80 | 890 | 95,7 | 96,0 | 96,0 | 0,75 | 0,81 | 0,81 | 80,3 |
| 500 | 675 | W22Xd 450K/H (1) | 5365 | 4,5 | 0,4 | 1,8 | 60,1 | 17 | 38 | 7000 | 80 | 890 | 95,7 | 96,0 | 96,0 | 0,75 | 0,81 | 0,81 | 89,2 |
| 560 | 755 | W22Xd 500K/H (1) | 5969 | 4,5 | 0,4 | 1,8 | 133 | 18 | 40 | 10500 | 85 | 896 | 95,9 | 96,3 | 96,4 | 0,73 | 0,80 | 0,80 | 101 |
| 630 | 850 | W22Xd 500K/H (1) | 6715 | 4,5 | 0,4 | 1,8 | 136 | 18 | 40 | 10600 | 85 | 896 | 95,9 | 96,4 | 96,4 | 0,73 | 0,80 | 0,80 | 113 |
| 710 | 960 | W22Xd 500K/H (1) | 7568 | 4,5 | 0,4 | 1,8 | 147 | 17 | 38 | 11200 | 85 | 896 | 96,0 | 96,4 | 96,5 | 0,73 | 0,80 | 0,80 | 128 |
| 710 | 960 | W22Xd 560H/G (1) | 7568 | 4,5 | 0,4 | 2,2 | 179 | 18 | 40 | 13260 | 87 | 896 | 96,0 | 96,5 | 96,6 | 0,68 | 0,78 | 0,78 | 131 |
| 800 | 1080 | W22Xd 560H/G (1) | 8527 | 4,5 | 0,4 | 2,2 | 188 | 18 | 40 | 13680 | 87 | 896 | 96,3 | 96,8 | 96,8 | 0,68 | 0,78 | 0,78 | 147 |

(1) Copper rotor

T_n = Full load torque
 I_S / I_n = Locked rotor current
 T_S / T_n = Locked rotor torque
 T_{max} / T_n = Breakdown torque
 I_n = Full load current

Notes:
 -The indicated values for sound pressure levels are @ 1m no load, with 3 dB(A) tolerance.
 -All values are according to IEC 60034-1 Standard tolerances.
 -This data can be changed without prior notice.

W22Xd Rib-Cooled Series / Optional - Anti-friction bearings arrangement
Low inrush current ($I_s / I_n \leq 4,5$)

| | | | | | | | | | | | | Y 6000V/50Hz | | | | | | | |
|--|------|------------------|------------|-------------|-------------|-----------------|-------------------------------|---|-------------|----------------------|-----|-----------------------|------|------|----------------------------|------|------|-----------|------|
| Output | | Frame IEC | T_n (Nm) | I_s / I_n | T_s / T_n | T_{max} / T_n | Inertia J (Kgm ²) | Allowable locked rotor time Hot/ Cold (s) | Weight (Kg) | Sound Pressure dB(A) | RPM | % of full load | | | | | | | |
| kW | HP | | | | | | | | | | | Efficiency η (%) | | | Power Factor Cos φ | | | I_n (A) | |
| | | | | | | | | | | | | 50 | 75 | 100 | 50 | 75 | 100 | | |
| II Pole - 3000 min⁻¹ | | | | | | | | | | | | | | | | | | | |
| 90 | 120 | W22Xd 355M/L | 288 | 4,5 | 0,9 | 1,9 | 3,3 | 15 | 32 | 2100 | 80 | 2980 | 90,2 | 92,4 | 93,2 | 0,85 | 0,87 | 0,88 | 10,6 |
| 110 | 150 | W22Xd 355M/L | 353 | 4,5 | 0,9 | 1,9 | 3,7 | 15 | 32 | 2200 | 80 | 2980 | 91,4 | 93,3 | 93,9 | 0,85 | 0,87 | 0,88 | 12,8 |
| 132 | 180 | W22Xd 355A/B | 423 | 4,5 | 0,9 | 1,9 | 4,8 | 14 | 31 | 2600 | 80 | 2980 | 92,6 | 94,1 | 94,6 | 0,87 | 0,88 | 0,88 | 15,3 |
| 160 | 215 | W22Xd 355A/B | 513 | 4,5 | 0,9 | 1,9 | 5,1 | 13 | 25 | 2700 | 80 | 2980 | 93,2 | 94,6 | 94,9 | 0,87 | 0,88 | 0,88 | 18,4 |
| 200 | 270 | W22Xd 355A/B | 641 | 4,5 | 0,9 | 1,9 | 5,4 | 13 | 25 | 2850 | 80 | 2980 | 94,0 | 95,1 | 95,3 | 0,87 | 0,88 | 0,88 | 22,9 |
| 250 | 340 | W22Xd 355A/B | 801 | 4,5 | 0,9 | 1,9 | 5,8 | 10 | 20 | 3050 | 80 | 2980 | 94,8 | 95,6 | 95,7 | 0,87 | 0,88 | 0,88 | 28,6 |
| 280 | 380 | W22Xd 400L/J | 897 | 4,5 | 0,9 | 1,8 | 9,9 | 9 | 19 | 4050 | 80 | 2982 | 94,8 | 95,7 | 95,8 | 0,84 | 0,86 | 0,86 | 32,7 |
| 315 | 425 | W22Xd 400L/J | 1009 | 4,5 | 0,9 | 1,8 | 10,2 | 8 | 17 | 4100 | 80 | 2982 | 95,0 | 95,8 | 96,0 | 0,84 | 0,86 | 0,86 | 36,7 |
| 355 | 480 | W22Xd 400L/J | 1137 | 4,5 | 0,9 | 1,8 | 10,8 | 8 | 16 | 4200 | 80 | 2982 | 95,3 | 96,0 | 96,2 | 0,84 | 0,86 | 0,86 | 41,3 |
| 400 | 540 | W22Xd 400G | 1281 | 4,5 | 0,9 | 1,8 | 12,5 | 8 | 16 | 5200 | 80 | 2982 | 95,4 | 96,1 | 96,3 | 0,84 | 0,86 | 0,86 | 46,5 |
| 450 | 610 | W22Xd 400G (1) | 1439 | 4,5 | 0,8 | 1,8 | 13,5 | 7 | 18 | 5400 | 80 | 2986 | 96,2 | 96,6 | 96,6 | 0,87 | 0,88 | 0,88 | 50,9 |
| 500 | 675 | W22Xd 450K/H (1) | 1599 | 4,5 | 0,7 | 1,7 | 14,3 | 8 | 22 | 6400 | 80 | 2986 | 95,9 | 96,6 | 96,7 | 0,86 | 0,88 | 0,88 | 56,5 |
| 560 | 755 | W22Xd 450K/H (1) | 1791 | 4,5 | 0,7 | 1,7 | 15,2 | 7 | 20 | 6650 | 80 | 2986 | 96,0 | 96,7 | 96,8 | 0,86 | 0,88 | 0,88 | 63,3 |
| 630 | 850 | W22Xd 500K/H (1) | 2014 | 4,5 | 0,9 | 1,8 | 21,7 | 10 | 18 | 9000 | 85 | 2987 | 96,1 | 96,5 | 96,9 | 0,87 | 0,89 | 0,89 | 70,3 |
| 710 | 960 | W22Xd 500K/H (1) | 2270 | 4,5 | 0,9 | 1,8 | 23,2 | 9 | 17 | 9200 | 85 | 2987 | 96,2 | 96,6 | 97,0 | 0,87 | 0,89 | 0,89 | 79,1 |
| 800 | 1080 | W22Xd 500K/H (1) | 2558 | 4,5 | 0,9 | 1,8 | 24,7 | 7 | 16 | 9650 | 85 | 2987 | 96,3 | 96,7 | 97,1 | 0,87 | 0,89 | 0,89 | 89,1 |
| 800 | 1080 | W22Xd 560H/G (1) | On request | | | | | | | | | | | | | | | | |
| 900 | 1215 | W22Xd 560H/G (1) | On request | | | | | | | | | | | | | | | | |

| | | | | | | | | | | | | | | | | | | | |
|--|------|------------------|------|-----|-----|-----|------|----|----|-------|----|------|------|------|------|------|------|------|------|
| IV Pole - 1500 min⁻¹ | | | | | | | | | | | | | | | | | | | |
| 90 | 120 | W22Xd 355M/L | 579 | 4,5 | 0,9 | 1,7 | 5,4 | 18 | 39 | 2200 | 76 | 1485 | 91,3 | 92,9 | 93,5 | 0,77 | 0,82 | 0,84 | 11,0 |
| 110 | 150 | W22Xd 355M/L | 707 | 4,5 | 0,9 | 1,7 | 6,3 | 16 | 34 | 2300 | 76 | 1485 | 91,6 | 93,2 | 93,8 | 0,77 | 0,82 | 0,84 | 13,4 |
| 132 | 180 | W22Xd 355A/B | 849 | 4,5 | 0,9 | 1,7 | 7,3 | 16 | 34 | 2775 | 76 | 1485 | 93,3 | 94,3 | 94,4 | 0,79 | 0,83 | 0,84 | 16,1 |
| 160 | 215 | W22Xd 355A/B | 1029 | 4,5 | 0,9 | 1,7 | 7,5 | 14 | 32 | 2900 | 76 | 1485 | 93,8 | 94,6 | 94,7 | 0,79 | 0,82 | 0,84 | 19,4 |
| 200 | 270 | W22Xd 355A/B | 1286 | 4,5 | 0,9 | 1,7 | 8,2 | 12 | 28 | 3050 | 76 | 1485 | 94,5 | 95,1 | 95,2 | 0,80 | 0,82 | 0,84 | 24,1 |
| 250 | 340 | W22Xd 355A/B | 1608 | 4,5 | 0,9 | 1,7 | 8,7 | 10 | 25 | 3250 | 76 | 1485 | 95,2 | 95,6 | 95,7 | 0,80 | 0,84 | 0,84 | 29,9 |
| 280 | 380 | W22Xd 400L/J | 1793 | 4,5 | 0,8 | 1,9 | 19,1 | 14 | 35 | 4200 | 80 | 1491 | 94,3 | 95,3 | 95,8 | 0,80 | 0,85 | 0,85 | 33,1 |
| 315 | 425 | W22Xd 400L/J | 2018 | 4,5 | 0,8 | 1,9 | 20,1 | 13 | 32 | 4350 | 80 | 1491 | 94,6 | 95,4 | 95,9 | 0,80 | 0,85 | 0,85 | 37,2 |
| 355 | 480 | W22Xd 400L/J | 2274 | 4,5 | 0,8 | 1,9 | 21,3 | 12 | 29 | 4550 | 80 | 1491 | 94,9 | 95,8 | 96,0 | 0,81 | 0,85 | 0,85 | 41,9 |
| 400 | 540 | W22Xd 400G (1) | 2569 | 4,5 | 0,5 | 1,9 | 25,9 | 16 | 36 | 5350 | 80 | 1487 | 96,0 | 96,2 | 96,3 | 0,83 | 0,87 | 0,87 | 45,9 |
| 450 | 610 | W22Xd 400G (1) | 2890 | 4,5 | 0,5 | 1,9 | 27,1 | 16 | 36 | 5540 | 80 | 1487 | 96,0 | 96,3 | 96,4 | 0,83 | 0,87 | 0,87 | 51,6 |
| 500 | 675 | W22Xd 400G (1) | 3211 | 4,5 | 0,5 | 1,9 | 27,6 | 14 | 32 | 5600 | 80 | 1487 | 96,1 | 96,4 | 96,5 | 0,83 | 0,87 | 0,87 | 57,3 |
| 560 | 755 | W22Xd 450K/H (1) | 3582 | 4,5 | 0,5 | 1,9 | 28,2 | 14 | 28 | 6700 | 80 | 1493 | 96,3 | 96,7 | 96,7 | 0,75 | 0,82 | 0,84 | 66,3 |
| 630 | 850 | W22Xd 450K/H (1) | 4030 | 4,5 | 0,5 | 1,9 | 29,6 | 12 | 24 | 7000 | 80 | 1493 | 96,4 | 96,8 | 96,8 | 0,75 | 0,82 | 0,84 | 74,6 |
| 710 | 960 | W22Xd 500K/H (1) | 4535 | 4,5 | 0,4 | 1,8 | 61,1 | 16 | 36 | 10000 | 80 | 1495 | 96,5 | 97,1 | 97,1 | 0,82 | 0,86 | 0,86 | 81,8 |
| 800 | 1080 | W22Xd 500K/H (1) | 5110 | 4,5 | 0,4 | 1,8 | 65,0 | 15 | 32 | 10250 | 80 | 1495 | 96,7 | 97,2 | 97,2 | 0,82 | 0,86 | 0,86 | 92,1 |
| 900 | 1215 | W22Xd 500K/H (1) | 5749 | 4,5 | 0,4 | 1,8 | 69,4 | 14 | 29 | 10500 | 80 | 1495 | 96,7 | 97,3 | 97,3 | 0,82 | 0,86 | 0,86 | 103 |
| 1000 | 1350 | W22Xd 500K/H (1) | 6388 | 4,5 | 0,4 | 1,8 | 72,2 | 13 | 26 | 11000 | 80 | 1495 | 96,9 | 97,4 | 97,4 | 0,82 | 0,86 | 0,86 | 115 |
| 1120 | 1515 | W22Xd 500K/H (1) | 7155 | 4,5 | 0,4 | 1,8 | 75,0 | 12 | 23 | 11200 | 80 | 1495 | 97,1 | 97,5 | 97,5 | 0,82 | 0,86 | 0,86 | 129 |
| 1120 | 1515 | W22Xd 560H/G (1) | 7150 | 4,5 | 0,4 | 2,0 | 98,3 | 16 | 31 | 12360 | 86 | 1496 | 97,1 | 97,5 | 97,5 | 0,84 | 0,87 | 0,87 | 127 |
| 1250 | 1690 | W22Xd 560H/G (1) | 7980 | 4,5 | 0,4 | 2,0 | 103 | 15 | 28 | 12720 | 86 | 1496 | 97,2 | 97,5 | 97,6 | 0,84 | 0,87 | 0,87 | 142 |

W22Xd Rib-Cooled Series / Optional - Anti-friction bearings arrangement
Low inrush current ($I_s / I_n \leq 4,5$)

| | | | | | | | | | | | | Y 6000V/50Hz | | | | | | | |
|---|------|------------------|------------|-------------|-------------|-----------------|-------------------------------|---|-------------|----------------------|-----|-----------------------|------|------|----------------------------|------|------|-----------|------|
| Output | | Frame IEC | T_n (Nm) | I_s / I_n | T_s / T_n | T_{max} / T_n | Inertia J (Kgm ²) | Allowable locked rotor time Hot/ Cold (s) | Weight (Kg) | Sound Pressure dB(A) | RPM | % of full load | | | | | | | |
| kW | HP | | | | | | | | | | | Efficiency η (%) | | | Power Factor Cos φ | | | I_n (A) | |
| | | | | | | | | | | | | 50 | 75 | 100 | 50 | 75 | 100 | | |
| VI Pole - 1000 min⁻¹ | | | | | | | | | | | | | | | | | | | |
| 110 | 150 | W22Xd 355A/B | 1061 | 4,5 | 0,9 | 1,6 | 9,3 | 19 | 40 | 2600 | 69 | 990 | 93,8 | 94,0 | 94,5 | 0,65 | 0,75 | 0,80 | 14,0 |
| 132 | 180 | W22Xd 355A/B | 1273 | 4,5 | 0,9 | 1,6 | 10,0 | 19 | 40 | 2700 | 69 | 990 | 94,0 | 94,3 | 94,8 | 0,65 | 0,75 | 0,80 | 16,7 |
| 160 | 215 | W22Xd 355A/B | 1543 | 4,5 | 0,9 | 1,6 | 10,8 | 17 | 36 | 2850 | 69 | 990 | 94,2 | 94,7 | 95,2 | 0,65 | 0,75 | 0,80 | 20,2 |
| 200 | 270 | W22Xd 355A/B | 1929 | 4,5 | 0,9 | 1,6 | 11,6 | 17 | 36 | 3050 | 69 | 990 | 94,5 | 95,0 | 95,5 | 0,66 | 0,75 | 0,80 | 25,2 |
| 250 | 340 | W22Xd 400L/J | 2412 | 4,5 | 0,6 | 1,6 | 22,9 | 16 | 35 | 4200 | 75 | 990 | 95,7 | 95,9 | 96,0 | 0,75 | 0,80 | 0,80 | 31,3 |
| 280 | 380 | W22Xd 400L/J | 2701 | 4,5 | 0,6 | 1,6 | 24,5 | 15 | 32 | 4400 | 75 | 990 | 95,7 | 95,9 | 96,0 | 0,75 | 0,80 | 0,80 | 35,1 |
| 315 | 425 | W22Xd 400G (1) | 3036 | 4,5 | 0,5 | 1,5 | 28,0 | 18 | 37 | 4800 | 75 | 991 | 95,6 | 95,9 | 96,0 | 0,81 | 0,82 | 0,83 | 38,0 |
| 355 | 480 | W22Xd 400G (1) | 3421 | 4,5 | 0,5 | 1,5 | 32,0 | 18 | 37 | 4850 | 75 | 991 | 95,8 | 96,0 | 96,1 | 0,80 | 0,82 | 0,83 | 42,8 |
| 400 | 540 | W22Xd 400G (1) | 3855 | 4,5 | 0,5 | 1,5 | 33,5 | 16 | 33 | 4900 | 75 | 991 | 95,9 | 96,1 | 96,1 | 0,80 | 0,82 | 0,83 | 48,3 |
| 450 | 610 | W22Xd 450K/H (1) | 4323 | 4,5 | 0,5 | 2,0 | 52,1 | 20 | 40 | 6600 | 76 | 994 | 95,8 | 96,3 | 96,3 | 0,78 | 0,83 | 0,85 | 52,9 |
| 500 | 675 | W22Xd 450K/H (1) | 4804 | 4,5 | 0,5 | 2,0 | 54,7 | 18 | 38 | 6800 | 76 | 994 | 96,0 | 96,5 | 96,5 | 0,79 | 0,84 | 0,85 | 58,7 |
| 560 | 755 | W22Xd 500K/H (1) | 5364 | 4,5 | 0,4 | 2,0 | 93,5 | 19 | 37 | 10400 | 80 | 997 | 96,4 | 96,7 | 96,7 | 0,75 | 0,83 | 0,85 | 65,6 |
| 630 | 850 | W22Xd 500K/H (1) | 6035 | 4,5 | 0,4 | 2,0 | 105 | 19 | 36 | 10650 | 80 | 997 | 96,6 | 96,9 | 96,9 | 0,75 | 0,83 | 0,85 | 73,6 |
| 710 | 960 | W22Xd 500K/H (1) | 6801 | 4,5 | 0,4 | 2,0 | 108 | 18 | 34 | 11100 | 80 | 997 | 96,7 | 97,0 | 97,0 | 0,75 | 0,83 | 0,85 | 82,9 |
| 800 | 1080 | W22Xd 500K/H (1) | 7663 | 4,5 | 0,4 | 2,0 | 110 | 16 | 31 | 11500 | 80 | 997 | 96,7 | 97,0 | 97,0 | 0,75 | 0,83 | 0,85 | 93,4 |
| 800 | 1080 | W22Xd 560H/G (1) | 7671 | 4,5 | 0,4 | 1,9 | 164 | 18 | 37 | 12600 | 82 | 996 | 96,7 | 97,0 | 97,0 | 0,78 | 0,84 | 0,85 | 93,4 |
| 900 | 1215 | W22Xd 560H/G (1) | 8630 | 4,5 | 0,4 | 1,9 | 171 | 15 | 32 | 12960 | 82 | 996 | 96,8 | 97,0 | 97,1 | 0,78 | 0,84 | 0,85 | 105 |
| VIII Pole - 750 min⁻¹ | | | | | | | | | | | | | | | | | | | |
| 132 | 180 | W22Xd 400L/J (1) | 1704 | 4,5 | 0,4 | 1,6 | 35,2 | 18 | 40 | 4000 | 74 | 740 | 94,0 | 95,5 | 96,0 | 0,75 | 0,80 | 0,81 | 16,3 |
| 160 | 215 | W22Xd 400L/J (1) | 2065 | 4,5 | 0,4 | 1,6 | 36,9 | 18 | 40 | 4200 | 74 | 740 | 94,3 | 95,8 | 96,0 | 0,75 | 0,80 | 0,81 | 19,8 |
| 200 | 270 | W22Xd 400L/J (1) | 2581 | 4,5 | 0,4 | 1,6 | 38,1 | 18 | 40 | 4400 | 74 | 740 | 94,3 | 95,8 | 96,1 | 0,75 | 0,80 | 0,81 | 24,7 |
| 250 | 340 | W22Xd 400G (1) | 3226 | 4,5 | 0,4 | 1,6 | 41,5 | 17 | 37 | 5050 | 74 | 740 | 94,9 | 95,8 | 96,2 | 0,75 | 0,80 | 0,81 | 30,9 |
| 280 | 380 | W22Xd 400G (1) | 3614 | 4,5 | 0,4 | 1,6 | 43,5 | 17 | 37 | 5150 | 74 | 740 | 94,9 | 95,8 | 96,2 | 0,75 | 0,80 | 0,81 | 34,6 |
| 315 | 425 | W22Xd 400G (1) | 4065 | 4,5 | 0,4 | 1,6 | 45,6 | 17 | 37 | 5200 | 74 | 740 | 94,9 | 95,8 | 96,2 | 0,75 | 0,80 | 0,81 | 38,9 |
| 355 | 480 | W22Xd 450K/H (1) | 4557 | 4,5 | 0,4 | 1,8 | 53,8 | 17 | 32 | 6400 | 75 | 744 | 96,0 | 96,3 | 96,3 | 0,75 | 0,81 | 0,81 | 43,8 |
| 400 | 540 | W22Xd 450K/H (1) | 5134 | 4,5 | 0,4 | 1,8 | 56,5 | 15 | 29 | 6700 | 75 | 744 | 96,0 | 96,3 | 96,3 | 0,75 | 0,81 | 0,81 | 49,3 |
| 450 | 610 | W22Xd 450K/H (1) | 5776 | 4,5 | 0,4 | 1,8 | 57,5 | 15 | 29 | 7000 | 75 | 744 | 96,0 | 96,3 | 96,3 | 0,75 | 0,81 | 0,81 | 55,5 |
| 500 | 675 | W22Xd 500K/H (1) | 6401 | 4,5 | 0,4 | 1,8 | 133 | 18 | 37 | 10500 | 80 | 746 | 96,8 | 96,8 | 96,8 | 0,75 | 0,81 | 0,81 | 61,4 |
| 560 | 755 | W22Xd 500K/H (1) | 7169 | 4,5 | 0,4 | 1,8 | 136 | 18 | 35 | 10600 | 80 | 746 | 96,9 | 96,9 | 96,9 | 0,74 | 0,81 | 0,81 | 68,7 |
| 630 | 850 | W22Xd 500K/H (1) | 8065 | 4,5 | 0,4 | 1,8 | 147 | 17 | 34 | 11200 | 80 | 746 | 96,9 | 97,0 | 97,0 | 0,73 | 0,80 | 0,80 | 78,1 |
| 710 | 960 | W22Xd 500K/H (1) | 9089 | 4,5 | 0,4 | 1,8 | 148 | 17 | 32 | 11800 | 80 | 746 | 96,9 | 97,1 | 97,1 | 0,73 | 0,80 | 0,80 | 88,0 |
| 710 | 960 | W22Xd 560H/G (1) | 10228 | 4,5 | 0,4 | 2,4 | 186 | 18 | 37 | 13540 | 82 | 747 | 96,9 | 97,2 | 97,2 | 0,70 | 0,78 | 0,79 | 89,0 |
| 800 | 1080 | W22Xd 560H/G (1) | 10228 | 4,5 | 0,4 | 2,4 | 188 | 15 | 32 | 13680 | 82 | 747 | 96,9 | 97,4 | 97,4 | 0,70 | 0,78 | 0,79 | 100 |

(1) Copper rotor

T_n = Full load torque
 I_s / I_n = Locked rotor current
 T_s / T_n = Locked rotor torque
 T_{max} / T_n = Breakdown torque
 I_n = Full load current

Notes:
 -The indicated values for sound pressure levels are @ 1m no load, with 3 dB(A) tolerance.
 -All values are according to IEC 60034-1 Standard tolerances.
 -This data can be changed without prior notice.

6.1.4. High Voltage - Electrical Data (6600V < U ≤ 11000V)

W22Xd Rib-Cooled Series / Optional - Anti-friction bearings arrangement
 Low inrush current (I_S / I_n ≤ 4,5)

| | | | | | | | | | | | | | Y 10000V/50Hz | | | | | | |
|---|------|------------------|---------------------|---------------------------------|---------------------------------|-----------------------------------|-------------------------------|---|-------------|----------------------|-----|------------------|---------------|------|--------------------|------|------|--------------------|------|
| Output | | Frame IEC | T _n (Nm) | I _s / I _n | T _s / T _n | T _{max} / T _n | Inertia J (Kgm ²) | Allowable locked rotor time Hot/ Cold (s) | Weight (Kg) | Sound Pressure dB(A) | RPM | % of full load | | | | | | I _n (A) | |
| kW | HP | | | | | | | | | | | Efficiency η (%) | | | Power Factor Cos φ | | | | |
| | | | | | | | | | | | | 50 | 75 | 100 | 50 | 75 | 100 | | |
| II Pole - 3000 min⁻¹ | | | | | | | | | | | | | | | | | | | |
| 355 | 480 | W22Xd 450K/H (1) | 1135 | 4,5 | 0,5 | 1,9 | 11,1 | 12 | 26 | 7050 | 80 | 2987 | 95,6 | 96,3 | 96,5 | 0,87 | 0,89 | 0,89 | 23,9 |
| 400 | 540 | W22Xd 500K/H (1) | 1279 | 4,5 | 0,5 | 1,9 | 12,7 | 14 | 38 | 9600 | 85 | 2987 | 95,8 | 96,4 | 96,5 | 0,87 | 0,90 | 0,90 | 26,6 |
| 450 | 610 | W22Xd 500K/H (1) | 1438 | 4,5 | 0,5 | 1,9 | 13,5 | 12 | 32 | 10050 | 85 | 2988 | 96,0 | 96,5 | 96,6 | 0,87 | 0,90 | 0,90 | 29,9 |
| 500 | 675 | W22Xd 500K/H (1) | 1598 | 4,5 | 0,5 | 2,0 | 14,2 | 11 | 24 | 10250 | 85 | 2988 | 96,3 | 96,8 | 96,8 | 0,87 | 0,90 | 0,90 | 33,1 |
| 500 | 675 | W22Xd 560H/G (1) | On request | | | | | | | | | | | | | | | | |
| 560 | 755 | W22Xd 560H/G (1) | On request | | | | | | | | | | | | | | | | |
| IV Pole - 1500min⁻¹ | | | | | | | | | | | | | | | | | | | |
| 355 | 480 | W22Xd 450K/H (1) | 2274 | 4,5 | 0,5 | 1,8 | 23,2 | 17 | 31 | 6400 | 80 | 1491 | 95,8 | 96,2 | 96,2 | 0,79 | 0,84 | 0,84 | 25,4 |
| 400 | 540 | W22Xd 450K/H (1) | 2560 | 4,5 | 0,5 | 1,9 | 24,6 | 15 | 28 | 7200 | 80 | 1492 | 96,0 | 96,3 | 96,3 | 0,80 | 0,85 | 0,85 | 28,2 |
| 450 | 610 | W22Xd 500K/H (1) | 2878 | 4,5 | 0,5 | 1,8 | 47,2 | 20 | 34 | 9900 | 80 | 1493 | 96,3 | 96,7 | 96,7 | 0,84 | 0,87 | 0,87 | 30,9 |
| 500 | 675 | W22Xd 500K/H (1) | 3198 | 4,5 | 0,5 | 1,8 | 51,1 | 18 | 32 | 10400 | 80 | 1493 | 96,4 | 96,8 | 96,8 | 0,84 | 0,87 | 0,87 | 34,3 |
| 560 | 755 | W22Xd 500K/H (1) | 3582 | 4,5 | 0,5 | 1,8 | 56,1 | 17 | 30 | 10930 | 80 | 1493 | 96,5 | 96,9 | 96,9 | 0,84 | 0,87 | 0,87 | 38,4 |
| 630 | 850 | W22Xd 500K/H (1) | 4030 | 4,5 | 0,5 | 1,8 | 61,1 | 16 | 28 | 11450 | 80 | 1493 | 96,7 | 97,0 | 97,0 | 0,84 | 0,87 | 0,87 | 43,1 |
| 630 | 850 | W22Xd 560H/G (1) | 4027 | 4,5 | 0,5 | 2,0 | 66,1 | 17 | 34 | 11450 | 86 | 1494 | 96,7 | 97,1 | 97,1 | 0,83 | 0,86 | 0,86 | 43,6 |
| 710 | 960 | W22Xd 560H/G (1) | 4538 | 4,5 | 0,5 | 2,0 | 69,4 | 16 | 31 | 11900 | 86 | 1494 | 96,8 | 97,2 | 97,2 | 0,83 | 0,86 | 0,86 | 49,0 |
| 800 | 1080 | W22Xd 560H/G (1) | 5114 | 4,5 | 0,5 | 2,0 | 74,7 | 16 | 30 | 12200 | 86 | 1494 | 97,0 | 97,4 | 97,4 | 0,83 | 0,86 | 0,86 | 55,1 |
| VI Pole - 1000min⁻¹ | | | | | | | | | | | | | | | | | | | |
| 280 | 380 | W22Xd 450K/H (1) | 2687 | 4,5 | 0,6 | 2,5 | 40,2 | 18 | 34 | 7300 | 76 | 995 | 95,2 | 95,9 | 96,0 | 0,74 | 0,82 | 0,84 | 20,0 |
| 315 | 425 | W22Xd 450K/H (1) | 3023 | 4,5 | 0,6 | 2,5 | 41,6 | 16 | 30 | 7500 | 76 | 995 | 95,5 | 96,1 | 96,2 | 0,74 | 0,82 | 0,84 | 22,5 |
| 355 | 480 | W22Xd 500K/H (1) | 3400 | 4,5 | 0,4 | 2,1 | 56,4 | 19 | 35 | 11050 | 80 | 997 | 96,0 | 96,3 | 96,3 | 0,80 | 0,84 | 0,84 | 25,3 |
| 400 | 540 | W22Xd 500K/H (1) | 3831 | 4,5 | 0,4 | 2,1 | 59,1 | 15 | 29 | 11500 | 80 | 997 | 96,1 | 96,4 | 96,4 | 0,80 | 0,84 | 0,84 | 28,5 |
| 450 | 610 | W22Xd 500K/H (1) | 4310 | 4,5 | 0,4 | 2,1 | 64,5 | 15 | 29 | 12200 | 80 | 997 | 96,3 | 96,6 | 96,6 | 0,80 | 0,84 | 0,84 | 32,0 |
| 450 | 610 | W22Xd 560H/G (1) | 4310 | 4,5 | 0,5 | 1,8 | 97,2 | 16 | 30 | 12300 | 82 | 997 | 96,4 | 96,6 | 96,7 | 0,79 | 0,83 | 0,83 | 32,4 |
| 500 | 675 | W22Xd 560H/G (1) | 4789 | 4,5 | 0,5 | 1,8 | 102 | 16 | 30 | 12450 | 82 | 997 | 96,5 | 96,7 | 96,8 | 0,79 | 0,83 | 0,83 | 35,9 |
| 560 | 755 | W22Xd 560H/G (1) | 5364 | 4,5 | 0,5 | 1,8 | 107 | 15 | 28 | 12900 | 82 | 997 | 96,5 | 96,7 | 96,8 | 0,79 | 0,83 | 0,83 | 40,2 |
| VIII Pole - 750 min⁻¹ | | | | | | | | | | | | | | | | | | | |
| 280 | 380 | W22Xd 500K/H (1) | 3584 | 4,5 | 0,5 | 1,6 | 113 | 18 | 36 | 11000 | 80 | 746 | 95,7 | 96,1 | 96,1 | 0,73 | 0,80 | 0,80 | 21,0 |
| 315 | 425 | W22Xd 500K/H (1) | 4033 | 4,5 | 0,5 | 1,6 | 118 | 16 | 32 | 11600 | 80 | 746 | 95,8 | 96,3 | 96,3 | 0,72 | 0,80 | 0,80 | 23,6 |
| 355 | 480 | W22Xd 500K/H (1) | 4545 | 4,5 | 0,5 | 1,6 | 132 | 16 | 32 | 12200 | 80 | 746 | 95,8 | 96,3 | 96,3 | 0,72 | 0,80 | 0,80 | 26,6 |
| 355 | 480 | W22Xd 560H/G (1) | 4532 | 4,5 | 0,4 | 2,1 | 155 | 16 | 32 | 12800 | 82 | 748 | 96,0 | 96,4 | 96,4 | 0,70 | 0,78 | 0,78 | 27,3 |
| 400 | 540 | W22Xd 560H/G (1) | 5107 | 4,5 | 0,4 | 2,1 | 163 | 14 | 28 | 13100 | 82 | 748 | 96,2 | 96,5 | 96,5 | 0,70 | 0,78 | 0,78 | 30,7 |

6

High voltage motors are also available on request for frame size 400.

(1) Copper rotor

T_n = Full load torque

T_{max} / T_n = Breakdown torque

I_s / I_n = Locked rotor current

I_n = Full load current

T_s / T_n = Locked rotor torque

Notes:

-The indicated values for sound pressure levels are @ 1m no load, with 3 dB(A) tolerance.

-All values are according to IEC 60034-1 Standard tolerances.

-This data can be changed without prior notice.

6.1.5. Medium Voltage - Electrical Data (1100V < U ≤ 6600V)

W22Xd Rib-Cooled Series / Optional - Sleeve Bearings arrangement

| Output | | Frame IEC | T _n (Nm) | I _s /I _n | T _s /T _n | T _{max} /T _n | Inertia J (Kgm ²) | Allowable locked rotor time Hot/Cold (s) | Weight (Kg) | Sound Pressure dB(A) | RPM | Y 3000V/50Hz | | | | | | | |
|--|------|------------------|---------------------|--------------------------------|--------------------------------|----------------------------------|-------------------------------|--|-------------|----------------------|-----|------------------|------|------|--------------------|------|------|--------------------|------|
| kW | HP | | | | | | | | | | | % of full load | | | | | | I _n (A) | |
| | | | | | | | | | | | | Efficiency η (%) | | | Power Factor Cos φ | | | | |
| | | | | | | | | | | | | 50 | 75 | 100 | 50 | 75 | 100 | | |
| II Pole - 3000 min⁻¹ | | | | | | | | | | | | | | | | | | | |
| 90 | 120 | W22Xd 315L | 289 | 6,7 | 1,5 | 2,5 | 1,3 | 7 | 15 | 1800 | 80 | 2978 | 91,5 | 93,6 | 94,5 | 0,70 | 0,81 | 0,86 | 21,3 |
| 110 | 150 | W22Xd 315L | 353 | 6,8 | 1,6 | 2,6 | 1,5 | 6 | 12 | 1850 | 80 | 2978 | 93,3 | 94,3 | 94,6 | 0,71 | 0,82 | 0,87 | 25,7 |
| 132 | 180 | W22Xd 315L | 423 | 6,8 | 1,6 | 2,6 | 1,6 | 6 | 12 | 1900 | 80 | 2978 | 93,9 | 94,6 | 94,7 | 0,72 | 0,82 | 0,87 | 30,8 |
| 160 | 215 | W22Xd 355M/L | 512 | 7,5 | 1,4 | 2,9 | 3,3 | 12 | 24 | 2100 | 80 | 2986 | 94,1 | 95,3 | 95,7 | 0,81 | 0,87 | 0,88 | 36,6 |
| 200 | 270 | W22Xd 355M/L | 640 | 7,5 | 1,4 | 2,9 | 3,7 | 10 | 20 | 2200 | 80 | 2986 | 94,5 | 95,5 | 95,9 | 0,81 | 0,86 | 0,88 | 45,6 |
| 250 | 340 | W22Xd 355A/B | 800 | 7,5 | 1,4 | 3,0 | 4,8 | 11 | 22 | 2600 | 80 | 2986 | 94,8 | 95,7 | 96,0 | 0,85 | 0,89 | 0,90 | 55,7 |
| 280 | 380 | W22Xd 355A/B | 896 | 7,5 | 1,4 | 3,0 | 5,1 | 10 | 20 | 2700 | 80 | 2986 | 95,0 | 95,9 | 96,2 | 0,85 | 0,89 | 0,90 | 62,2 |
| 315 | 425 | W22Xd 355A/B | 1007 | 7,5 | 1,5 | 3,0 | 5,4 | 9 | 18 | 2850 | 80 | 2986 | 95,1 | 96,0 | 96,3 | 0,84 | 0,88 | 0,90 | 69,9 |
| 355 | 480 | W22Xd 355A/B | 1135 | 7,5 | 1,5 | 3,1 | 5,8 | 8 | 16 | 3050 | 80 | 2986 | 95,3 | 96,1 | 96,4 | 0,83 | 0,88 | 0,90 | 78,7 |
| 400 | 540 | W22Xd 400L/J | 1279 | 6,5 | 1,5 | 2,6 | 9,9 | 8 | 16 | 4050 | 80 | 2986 | 95,5 | 96,3 | 96,6 | 0,82 | 0,87 | 0,88 | 90,6 |
| 450 | 610 | W22Xd 400L/J | 1439 | 6,5 | 1,5 | 2,6 | 10,2 | 7 | 14 | 4100 | 80 | 2986 | 95,9 | 96,6 | 96,8 | 0,83 | 0,87 | 0,88 | 102 |
| 500 | 675 | W22Xd 400L/J | 1599 | 6,7 | 1,7 | 2,8 | 10,8 | 6 | 12 | 4200 | 80 | 2986 | 95,9 | 96,7 | 97,0 | 0,81 | 0,86 | 0,88 | 113 |
| 560 | 755 | W22Xd 450K/H (1) | 1789 | 6,5 | 0,6 | 2,9 | 12,2 | 15 | 38 | 5980 | 80 | 2989 | 96,3 | 97,0 | 97,1 | 0,84 | 0,89 | 0,90 | 123 |
| 630 | 850 | W22Xd 450K/H (1) | 2013 | 6,5 | 0,6 | 2,9 | 12,9 | 15 | 36 | 6110 | 80 | 2989 | 96,4 | 97,1 | 97,2 | 0,84 | 0,89 | 0,90 | 139 |
| 710 | 960 | W22Xd 450K/H (1) | 2267 | 6,8 | 0,6 | 2,9 | 13,4 | 14 | 36 | 6240 | 80 | 2989 | 96,4 | 97,2 | 97,4 | 0,84 | 0,89 | 0,90 | 156 |
| 800 | 1080 | W22Xd 500K/H (1) | 2554 | 5,9 | 0,6 | 2,6 | 20,7 | 15 | 36 | 8800 | 82 | 2990 | 97,0 | 97,5 | 97,6 | 0,85 | 0,90 | 0,91 | 173 |
| 900 | 1215 | W22Xd 500K/H (1) | 2875 | 5,9 | 0,6 | 2,6 | 21,7 | 14 | 36 | 9000 | 82 | 2990 | 97,0 | 97,6 | 97,7 | 0,85 | 0,90 | 0,91 | 195 |
| 1000 | 1350 | W22Xd 500K/H (1) | 3193 | 6,1 | 0,7 | 2,8 | 23,2 | 10 | 26 | 9200 | 82 | 2991 | 97,2 | 97,7 | 97,8 | 0,85 | 0,90 | 0,91 | 216 |
| 1120 | 1515 | W22Xd 500K/H (1) | 3576 | 6,5 | 0,8 | 3,0 | 24,7 | 8 | 20 | 9650 | 82 | 2991 | 97,2 | 97,7 | 97,9 | 0,85 | 0,90 | 0,91 | 242 |
| 1120 | 1515 | W22Xd 560H/G (1) | On request | | | | | | | | | | | | | | | | |
| 1250 | 1690 | W22Xd 560H/G (1) | On request | | | | | | | | | | | | | | | | |

| | | | | | | | | | | | | | | | | | | | |
|--|------|------------------|-------|-----|-----|-----|------|----|----|-------|----|------|------|------|------|------|------|------|------|
| IV Pole - 1500 min⁻¹ | | | | | | | | | | | | | | | | | | | |
| 90 | 120 | W22Xd 315L | 579 | 6,7 | 1,2 | 2,5 | 2,6 | 20 | 40 | 1785 | 76 | 1484 | 93,0 | 94,2 | 94,5 | 0,70 | 0,80 | 0,83 | 22,0 |
| 110 | 150 | W22Xd 315L | 708 | 6,7 | 1,3 | 2,5 | 2,8 | 15 | 32 | 1825 | 76 | 1484 | 93,0 | 94,2 | 94,5 | 0,70 | 0,80 | 0,83 | 26,9 |
| 132 | 180 | W22Xd 315L | 849 | 6,7 | 1,3 | 2,5 | 3,1 | 15 | 32 | 1875 | 76 | 1484 | 93,0 | 94,2 | 94,6 | 0,70 | 0,80 | 0,83 | 32,2 |
| 160 | 215 | W22Xd 355M/L | 1025 | 6,7 | 1,5 | 2,9 | 5,4 | 18 | 39 | 2200 | 76 | 1491 | 94,5 | 95,5 | 95,8 | 0,73 | 0,81 | 0,84 | 38,3 |
| 200 | 270 | W22Xd 355M/L | 1281 | 6,7 | 1,5 | 2,9 | 6,3 | 16 | 34 | 2300 | 76 | 1491 | 95,1 | 95,9 | 96,1 | 0,73 | 0,81 | 0,84 | 47,7 |
| 250 | 340 | W22Xd 355A/B | 1601 | 7,2 | 1,5 | 2,9 | 7,3 | 11 | 23 | 2775 | 76 | 1491 | 95,1 | 95,9 | 96,1 | 0,71 | 0,80 | 0,84 | 59,7 |
| 280 | 380 | W22Xd 355A/B | 1793 | 7,2 | 1,5 | 2,9 | 7,5 | 10 | 21 | 2900 | 76 | 1491 | 95,4 | 96,1 | 96,2 | 0,73 | 0,82 | 0,84 | 66,7 |
| 315 | 425 | W22Xd 355A/B | 2018 | 7,2 | 1,6 | 2,9 | 8,2 | 9 | 19 | 3050 | 76 | 1491 | 95,4 | 96,2 | 96,3 | 0,72 | 0,81 | 0,84 | 74,9 |
| 355 | 480 | W22Xd 355A/B | 2274 | 7,2 | 1,6 | 2,9 | 8,7 | 9 | 19 | 3250 | 76 | 1491 | 95,4 | 96,2 | 96,3 | 0,71 | 0,80 | 0,84 | 84,5 |
| 400 | 540 | W22Xd 400L/J | 2559 | 6,5 | 1,4 | 2,8 | 19,1 | 12 | 28 | 4200 | 80 | 1493 | 95,0 | 96,0 | 96,3 | 0,77 | 0,84 | 0,86 | 93,0 |
| 450 | 610 | W22Xd 400L/J | 2878 | 6,5 | 1,4 | 2,8 | 20,1 | 11 | 25 | 4350 | 80 | 1493 | 95,1 | 96,1 | 96,4 | 0,77 | 0,84 | 0,86 | 104 |
| 500 | 675 | W22Xd 400L/J | 3198 | 6,5 | 1,4 | 2,8 | 21,3 | 10 | 23 | 4550 | 80 | 1493 | 95,4 | 96,3 | 96,6 | 0,77 | 0,84 | 0,86 | 116 |
| 560 | 755 | W22Xd 400G (1) | 3584 | 6,1 | 0,7 | 2,8 | 25,9 | 13 | 26 | 5350 | 80 | 1492 | 96,4 | 96,9 | 97,0 | 0,82 | 0,88 | 0,89 | 125 |
| 630 | 850 | W22Xd 450K/H (1) | 4030 | 6,0 | 0,7 | 2,5 | 25,5 | 15 | 32 | 6380 | 80 | 1493 | 96,7 | 97,1 | 97,2 | 0,79 | 0,85 | 0,87 | 143 |
| 710 | 960 | W22Xd 450K/H (1) | 4542 | 6,0 | 0,7 | 2,5 | 26,7 | 15 | 30 | 6560 | 80 | 1493 | 96,8 | 97,2 | 97,2 | 0,79 | 0,85 | 0,87 | 162 |
| 800 | 1080 | W22Xd 450K/H (1) | 5117 | 6,1 | 0,8 | 2,6 | 28,2 | 14 | 28 | 6700 | 80 | 1493 | 96,9 | 97,3 | 97,4 | 0,78 | 0,85 | 0,87 | 182 |
| 900 | 1215 | W22Xd 450K/H (1) | 5757 | 6,1 | 0,8 | 2,5 | 29,7 | 13 | 25 | 7000 | 80 | 1493 | 96,9 | 97,3 | 97,4 | 0,79 | 0,85 | 0,87 | 204 |
| 1000 | 1350 | W22Xd 500K/H (1) | 6388 | 6,0 | 0,6 | 2,3 | 61,1 | 13 | 27 | 10000 | 80 | 1495 | 96,9 | 97,4 | 97,5 | 0,84 | 0,88 | 0,89 | 222 |
| 1120 | 1515 | W22Xd 500K/H (1) | 7155 | 6,0 | 0,6 | 2,3 | 65,0 | 12 | 27 | 10250 | 80 | 1495 | 97,0 | 97,5 | 97,6 | 0,84 | 0,88 | 0,89 | 248 |
| 1250 | 1690 | W22Xd 500K/H (1) | 7985 | 6,1 | 0,6 | 2,3 | 69,4 | 11 | 25 | 10500 | 80 | 1495 | 97,1 | 97,6 | 97,7 | 0,83 | 0,88 | 0,89 | 277 |
| 1400 | 1890 | W22Xd 500K/H (1) | 8943 | 6,4 | 0,6 | 2,3 | 72,2 | 10 | 22 | 11000 | 80 | 1495 | 97,1 | 97,6 | 97,7 | 0,83 | 0,88 | 0,89 | 310 |
| 1400 | 1890 | W22Xd 560H/G (1) | 8937 | 6,0 | 0,5 | 2,7 | 98,3 | 12 | 22 | 12360 | 86 | 1496 | 97,1 | 97,6 | 97,7 | 0,82 | 0,87 | 0,88 | 313 |
| 1600 | 2160 | W22Xd 560H/G (1) | 10214 | 6,0 | 0,5 | 2,7 | 103 | 12 | 22 | 12720 | 86 | 1496 | 97,2 | 97,7 | 97,8 | 0,82 | 0,87 | 0,88 | 358 |



W22Xd Rib-Cooled Series / Optional - Sleeve Bearings arrangement

| | | | | | | | | | | | | | Y 3000V/50Hz | | | | | | |
|--|------|------------------|---------------------|--------------------------------|--------------------------------|----------------------------------|-------------------------------|--|-------------|----------------------|-----|------------------|--------------|------|--------------------|------|------|--------------------|------|
| Output | | Frame IEC | T _n (Nm) | I _s /I _n | T _s /T _n | T _{max} /T _n | Inertia J (Kgm ²) | Allowable locked rotor time Hot/Cold (s) | Weight (Kg) | Sound Pressure dB(A) | RPM | % of full load | | | | | | | |
| kW | HP | | | | | | | | | | | Efficiency η (%) | | | Power Factor Cos φ | | | I _n (A) | |
| | | | | | | | | | | | | 50 | 75 | 100 | 50 | 75 | 100 | | |
| VI Pole - 1000 min⁻¹ | | | | | | | | | | | | | | | | | | | |
| 90 | 120 | W22Xd 315L | 864 | 6,7 | 1,2 | 2,4 | 4,2 | 18 | 40 | 1850 | 69 | 995 | 93,4 | 94,5 | 94,6 | 0,59 | 0,69 | 0,75 | 24,4 |
| 110 | 150 | W22Xd 315L | 1056 | 6,7 | 1,2 | 2,4 | 4,6 | 18 | 40 | 1950 | 69 | 995 | 93,6 | 94,6 | 94,7 | 0,59 | 0,69 | 0,75 | 29,8 |
| 132 | 180 | W22Xd 355M/L | 1269 | 6,0 | 1,3 | 2,3 | 6,9 | 20 | 40 | 2250 | 69 | 993 | 94,7 | 95,5 | 95,5 | 0,65 | 0,75 | 0,80 | 33,3 |
| 160 | 215 | W22Xd 355M/L | 1539 | 6,0 | 1,4 | 2,3 | 7,7 | 20 | 40 | 2350 | 69 | 993 | 94,9 | 95,5 | 95,6 | 0,65 | 0,75 | 0,80 | 40,3 |
| 200 | 270 | W22Xd 355A/B | 1923 | 6,3 | 1,5 | 2,3 | 9,3 | 20 | 40 | 2600 | 69 | 993 | 95,0 | 95,6 | 95,7 | 0,65 | 0,75 | 0,80 | 50,3 |
| 250 | 340 | W22Xd 355A/B | 2404 | 6,3 | 1,5 | 2,3 | 10,0 | 20 | 40 | 2700 | 69 | 993 | 95,1 | 95,7 | 95,7 | 0,65 | 0,75 | 0,80 | 62,8 |
| 280 | 380 | W22Xd 355A/B | 2693 | 6,3 | 1,5 | 2,3 | 10,8 | 19 | 38 | 2850 | 69 | 993 | 95,4 | 95,9 | 95,9 | 0,65 | 0,75 | 0,80 | 70,2 |
| 315 | 425 | W22Xd 355A/B | 3029 | 6,3 | 1,5 | 2,3 | 11,6 | 19 | 38 | 3050 | 69 | 993 | 95,5 | 96,0 | 96,0 | 0,66 | 0,75 | 0,80 | 78,9 |
| 355 | 480 | W22Xd 400L/J | 3421 | 6,2 | 1,0 | 2,3 | 22,9 | 16 | 35 | 4200 | 75 | 991 | 96,1 | 96,4 | 96,5 | 0,72 | 0,78 | 0,82 | 86,3 |
| 400 | 540 | W22Xd 400L/J | 3855 | 6,2 | 1,0 | 2,3 | 24,5 | 15 | 32 | 4400 | 75 | 991 | 96,2 | 96,6 | 96,5 | 0,73 | 0,80 | 0,82 | 97,3 |
| 450 | 610 | W22Xd 400G (1) | 4319 | 6,0 | 0,6 | 2,3 | 28,0 | 18 | 37 | 4800 | 75 | 995 | 95,6 | 96,0 | 96,2 | 0,81 | 0,82 | 0,83 | 108 |
| 500 | 675 | W22Xd 400G (1) | 4799 | 6,0 | 0,7 | 2,3 | 32,0 | 18 | 37 | 4850 | 75 | 995 | 95,5 | 96,0 | 96,2 | 0,80 | 0,82 | 0,83 | 121 |
| 560 | 755 | W22Xd 400G (1) | 5375 | 6,0 | 0,7 | 2,3 | 33,5 | 16 | 33 | 4900 | 75 | 995 | 95,9 | 96,2 | 96,4 | 0,80 | 0,82 | 0,83 | 135 |
| 630 | 850 | W22Xd 450K/H (1) | 6047 | 6,0 | 0,7 | 3,0 | 52,0 | 20 | 40 | 6600 | 76 | 995 | 96,1 | 96,8 | 97,0 | 0,73 | 0,81 | 0,85 | 147 |
| 710 | 960 | W22Xd 450K/H (1) | 6815 | 6,0 | 0,7 | 3,0 | 54,6 | 19 | 38 | 6800 | 76 | 995 | 96,3 | 96,9 | 97,1 | 0,74 | 0,82 | 0,85 | 166 |
| 800 | 1080 | W22Xd 500K/H (1) | 7663 | 6,0 | 0,7 | 2,7 | 93,5 | 19 | 37 | 10400 | 80 | 997 | 96,9 | 97,2 | 97,3 | 0,78 | 0,84 | 0,86 | 184 |
| 900 | 1215 | W22Xd 500K/H (1) | 8621 | 6,1 | 0,8 | 2,7 | 105 | 19 | 36 | 10650 | 80 | 997 | 96,9 | 97,2 | 97,3 | 0,78 | 0,85 | 0,86 | 207 |
| 900 | 1215 | W22Xd 560H/G (1) | 8621 | 6,0 | 0,6 | 2,5 | 148 | 19 | 39 | 11850 | 82 | 997 | 97,0 | 97,4 | 97,5 | 0,77 | 0,84 | 0,86 | 207 |
| 1000 | 1350 | W22Xd 560H/G (1) | 9579 | 6,0 | 0,6 | 2,5 | 155 | 18 | 37 | 12180 | 82 | 997 | 97,0 | 97,4 | 97,5 | 0,78 | 0,84 | 0,86 | 230 |
| 1120 | 1515 | W22Xd 560H/G (1) | 10728 | 6,0 | 0,6 | 2,6 | 164 | 18 | 37 | 12600 | 82 | 997 | 96,9 | 97,4 | 97,5 | 0,77 | 0,84 | 0,86 | 257 |
| 1250 | 1690 | W22Xd 560H/G (1) | 11973 | 6,0 | 0,6 | 2,6 | 172 | 15 | 32 | 12960 | 82 | 997 | 97,0 | 97,4 | 97,5 | 0,79 | 0,85 | 0,86 | 287 |

| | | | | | | | | | | | | | | | | | | | |
|---|------|------------------|-------|-----|-----|-----|------|----|----|-------|----|-----|------|------|------|------|------|------|------|
| VIII Pole - 750 min⁻¹ | | | | | | | | | | | | | | | | | | | |
| 90 | 120 | W22Xd 315L | 1158 | 7,5 | 1,4 | 2,4 | 3,8 | 17 | 37 | 2050 | 65 | 742 | 89,3 | 91,3 | 92,0 | 0,50 | 0,63 | 0,71 | 26,5 |
| 110 | 150 | W22Xd 355M/L | 1420 | 6,8 | 1,3 | 2,4 | 7,5 | 18 | 40 | 2450 | 65 | 740 | 94,0 | 94,5 | 94,5 | 0,69 | 0,77 | 0,80 | 28,0 |
| 132 | 180 | W22Xd 355A/B | 1704 | 6,8 | 1,3 | 2,4 | 8,1 | 18 | 40 | 2650 | 65 | 740 | 94,6 | 94,6 | 94,6 | 0,71 | 0,78 | 0,80 | 33,6 |
| 160 | 215 | W22Xd 355A/B | 2065 | 6,8 | 1,3 | 2,4 | 8,9 | 18 | 40 | 2950 | 65 | 740 | 94,8 | 95,0 | 94,7 | 0,71 | 0,78 | 0,80 | 40,6 |
| 200 | 270 | W22Xd 400L/J (1) | 2581 | 5,0 | 0,6 | 2,1 | 35,2 | 18 | 40 | 4000 | 74 | 740 | 95,7 | 96,2 | 96,4 | 0,73 | 0,80 | 0,82 | 48,7 |
| 250 | 340 | W22Xd 400G (1) | 3226 | 5,0 | 0,6 | 2,1 | 36,9 | 18 | 40 | 4500 | 74 | 740 | 95,7 | 96,2 | 96,4 | 0,71 | 0,79 | 0,82 | 60,9 |
| 280 | 380 | W22Xd 400G (1) | 3614 | 5,0 | 0,6 | 2,1 | 38,1 | 18 | 40 | 4700 | 74 | 740 | 95,7 | 96,2 | 96,4 | 0,71 | 0,79 | 0,82 | 68,2 |
| 315 | 425 | W22Xd 400G (1) | 4065 | 5,0 | 0,6 | 2,1 | 41,5 | 17 | 37 | 5050 | 74 | 740 | 95,8 | 96,3 | 96,4 | 0,71 | 0,79 | 0,82 | 76,7 |
| 355 | 480 | W22Xd 400G (1) | 4581 | 5,0 | 0,6 | 2,1 | 43,5 | 17 | 37 | 5150 | 74 | 740 | 95,8 | 96,3 | 96,4 | 0,69 | 0,78 | 0,82 | 86,4 |
| 400 | 540 | W22Xd 400G (1) | 5162 | 5,0 | 0,6 | 2,1 | 45,6 | 17 | 37 | 5200 | 74 | 740 | 95,9 | 96,4 | 96,4 | 0,73 | 0,80 | 0,82 | 97,4 |
| 450 | 610 | W22Xd 450K/H (1) | 5768 | 5,0 | 0,6 | 2,4 | 53,8 | 17 | 32 | 6400 | 75 | 745 | 95,8 | 96,4 | 96,5 | 0,69 | 0,79 | 0,82 | 109 |
| 500 | 675 | W22Xd 450K/H (1) | 6409 | 5,0 | 0,6 | 2,4 | 56,5 | 15 | 29 | 6700 | 75 | 745 | 95,8 | 96,4 | 96,5 | 0,71 | 0,80 | 0,82 | 122 |
| 560 | 755 | W22Xd 450K/H (1) | 7179 | 5,0 | 0,6 | 2,4 | 57,5 | 15 | 29 | 7000 | 75 | 745 | 95,8 | 96,4 | 96,5 | 0,71 | 0,79 | 0,82 | 136 |
| 630 | 850 | W22Xd 500K/H (1) | 8065 | 5,5 | 0,8 | 2,4 | 133 | 18 | 37 | 10500 | 80 | 746 | 96,7 | 97,0 | 97,0 | 0,73 | 0,80 | 0,80 | 156 |
| 710 | 960 | W22Xd 500K/H (1) | 9089 | 5,5 | 0,8 | 2,4 | 136 | 18 | 35 | 10600 | 80 | 746 | 96,7 | 97,0 | 97,0 | 0,72 | 0,79 | 0,80 | 176 |
| 710 | 960 | W22Xd 560H/G (1) | 9065 | 5,9 | 0,6 | 3 | 166 | 19 | 39 | 12420 | 82 | 748 | 96,7 | 97,2 | 97,2 | 0,66 | 0,76 | 0,80 | 176 |
| 800 | 1080 | W22Xd 560H/G (1) | 10214 | 5,9 | 0,6 | 3 | 175 | 18 | 37 | 12940 | 82 | 748 | 96,7 | 97,2 | 97,2 | 0,66 | 0,76 | 0,80 | 198 |
| 900 | 1215 | W22Xd 560H/G (1) | 11491 | 5,9 | 0,6 | 3 | 186 | 18 | 37 | 13540 | 82 | 748 | 96,8 | 97,3 | 97,3 | 0,66 | 0,76 | 0,80 | 223 |
| 1000 | 1350 | W22Xd 560H/G (1) | 12767 | 5,9 | 0,6 | 3 | 188 | 15 | 32 | 13680 | 82 | 748 | 96,9 | 97,4 | 97,4 | 0,66 | 0,76 | 0,80 | 247 |

(1) Copper rotor

T_n = Full load torque
 I_s / I_n = Locked rotor current
 T_s / T_n = Locked rotor torque
 T_{max} / T_n = Breakdown torque
 I_n = Full load current

Notes:
 -The indicated values for sound pressure levels are @ 1m no load, with 3 dB(A) tolerance.
 -All values are according to IEC 60034-1 Standard tolerances.
 -This data can be changed without prior notice.

W22Xd Rib-Cooled Series / Optional - Sleeve Bearings arrangement

| Output | | Frame IEC | T _n (Nm) | I _s /I _n | T _s /T _n | T _{max} /T _n | Inertia J (Kgm²) | Allowable locked rotor time Hot/Cold (s) | Weight (Kg) | Sound Pressure dB(A) | RPM | Y 4160V/60Hz | | | | | | I _n (A) |
|--------|----|-----------|---------------------|--------------------------------|--------------------------------|----------------------------------|------------------|--|-------------|----------------------|-----|------------------|--|--|--------------------|--|--|--------------------|
| kW | HP | | | | | | | | | | | % of full load | | | | | | |
| | | | | | | | | | | | | Efficiency η (%) | | | Power Factor Cos φ | | | |
| | | 50 | 75 | 100 | 50 | 75 | 100 | | | | | | | | | | | |

II Pole - 3000 min⁻¹

| | | | | | | | | | | | | | | | | | | | |
|------|------|------------------|------|-----|-----|-----|------|----|----|------|----|------|------|------|------|------|------|------|------|
| 90 | 120 | W22Xd 315L | 240 | 6,7 | 1,5 | 2,5 | 1,2 | 10 | 20 | 1750 | 85 | 3577 | 88,9 | 91,8 | 93,1 | 0,76 | 0,83 | 0,86 | 15,6 |
| 110 | 150 | W22Xd 315L | 294 | 6,8 | 1,6 | 2,6 | 1,3 | 8 | 16 | 1800 | 85 | 3577 | 90,0 | 92,6 | 93,7 | 0,76 | 0,83 | 0,86 | 18,9 |
| 132 | 180 | W22Xd 315L | 352 | 6,8 | 1,6 | 2,6 | 1,4 | 7 | 14 | 1850 | 85 | 3577 | 90,7 | 93,1 | 94,2 | 0,76 | 0,83 | 0,86 | 22,6 |
| 160 | 215 | W22Xd 355M/L | 426 | 7,0 | 1,3 | 3,0 | 2,9 | 13 | 26 | 2000 | 85 | 3585 | 91,5 | 93,5 | 94,2 | 0,81 | 0,87 | 0,88 | 26,8 |
| 200 | 270 | W22Xd 355M/L | 533 | 7,0 | 1,3 | 3,0 | 3,3 | 12 | 24 | 2100 | 85 | 3585 | 92,5 | 94,2 | 94,8 | 0,81 | 0,87 | 0,89 | 32,9 |
| 250 | 340 | W22Xd 355M/L | 666 | 7,0 | 1,3 | 3,0 | 4,3 | 11 | 22 | 2300 | 85 | 3585 | 93,4 | 94,7 | 95,2 | 0,83 | 0,88 | 0,89 | 41,0 |
| 280 | 380 | W22Xd 355A/B | 746 | 7,0 | 1,4 | 3,0 | 4,8 | 9 | 16 | 2600 | 85 | 3585 | 93,9 | 95,1 | 95,5 | 0,85 | 0,89 | 0,90 | 45,2 |
| 315 | 425 | W22Xd 355A/B | 839 | 7,0 | 1,4 | 3,0 | 5,1 | 9 | 16 | 2700 | 85 | 3585 | 94,4 | 95,5 | 95,8 | 0,85 | 0,89 | 0,90 | 50,7 |
| 355 | 480 | W22Xd 355A/B | 946 | 7,0 | 1,5 | 3,0 | 5,4 | 8 | 14 | 2850 | 85 | 3585 | 94,7 | 95,7 | 96,0 | 0,85 | 0,89 | 0,90 | 57,0 |
| 400 | 540 | W22Xd 355A/B | 1066 | 7,0 | 1,5 | 3,0 | 5,8 | 8 | 14 | 3050 | 85 | 3585 | 94,8 | 95,8 | 96,2 | 0,85 | 0,89 | 0,90 | 64,1 |
| 450 | 610 | W22Xd 400L/J | 1199 | 7,0 | 1,7 | 2,8 | 9,9 | 6 | 12 | 4050 | 85 | 3585 | 94,8 | 95,9 | 96,3 | 0,82 | 0,87 | 0,88 | 73,7 |
| 500 | 675 | W22Xd 400L/J | 1332 | 7,0 | 1,7 | 2,8 | 10,2 | 6 | 12 | 4100 | 85 | 3585 | 95,1 | 96,1 | 96,4 | 0,82 | 0,87 | 0,88 | 81,8 |
| 560 | 755 | W22Xd 450K/H (1) | 1490 | 6,0 | 0,6 | 2,6 | 12,0 | 13 | 40 | 5980 | 85 | 3590 | 95,8 | 96,4 | 96,7 | 0,83 | 0,88 | 0,89 | 90,3 |
| 630 | 850 | W22Xd 450K/H (1) | 1676 | 6,0 | 0,6 | 2,6 | 12,9 | 13 | 40 | 6110 | 85 | 3590 | 95,9 | 96,5 | 96,8 | 0,83 | 0,88 | 0,89 | 101 |
| 710 | 960 | W22Xd 450K/H (1) | 1889 | 6,0 | 0,6 | 2,6 | 13,5 | 12 | 40 | 6240 | 85 | 3590 | 96,1 | 96,7 | 97,0 | 0,84 | 0,89 | 0,90 | 113 |
| 800 | 1080 | W22Xd 450K/H (1) | 2128 | 6,0 | 0,6 | 2,6 | 14,3 | 12 | 40 | 6400 | 85 | 3590 | 96,3 | 97,0 | 97,2 | 0,85 | 0,89 | 0,90 | 127 |
| 900 | 1215 | W22Xd 450K/H (1) | 2394 | 6,0 | 0,6 | 2,6 | 15,2 | 10 | 36 | 6650 | 85 | 3590 | 96,4 | 97,2 | 97,4 | 0,85 | 0,89 | 0,90 | 142 |
| 1000 | 1350 | W22Xd 500K/H (1) | | | | | | | | | | | | | | | | | |
| 1120 | 1515 | W22Xd 500K/H (1) | | | | | | | | | | | | | | | | | |
| 1120 | 1515 | W22Xd 560H/G (1) | | | | | | | | | | | | | | | | | |
| 1250 | 1690 | W22Xd 560H/G (1) | | | | | | | | | | | | | | | | | |

On request

IV Pole - 1500 min⁻¹

| | | | | | | | | | | | | | | | | | | | |
|------|------|------------------|------|-----|-----|-----|------|----|----|-------|----|------|------|------|------|------|------|------|------|
| 90 | 120 | W22Xd 315L | 483 | 6,5 | 1,1 | 2,3 | 2,3 | 20 | 40 | 1725 | 81 | 1781 | 91,4 | 93,3 | 94,0 | 0,73 | 0,82 | 0,85 | 15,6 |
| 110 | 150 | W22Xd 315L | 590 | 6,5 | 1,1 | 2,3 | 2,6 | 15 | 32 | 1785 | 81 | 1781 | 92,2 | 93,8 | 94,4 | 0,73 | 0,82 | 0,85 | 19,0 |
| 132 | 180 | W22Xd 315L | 708 | 6,5 | 1,1 | 2,3 | 2,8 | 15 | 32 | 1825 | 81 | 1781 | 92,6 | 94,0 | 94,6 | 0,73 | 0,82 | 0,85 | 22,8 |
| 160 | 215 | W22Xd 355M/L | 853 | 6,5 | 1,4 | 2,8 | 4,8 | 18 | 39 | 2100 | 81 | 1791 | 91,4 | 93,8 | 94,7 | 0,70 | 0,80 | 0,84 | 27,9 |
| 200 | 270 | W22Xd 355M/L | 1066 | 6,5 | 1,4 | 2,8 | 5,4 | 16 | 34 | 2200 | 81 | 1791 | 92,1 | 94,3 | 95,2 | 0,70 | 0,80 | 0,84 | 34,7 |
| 250 | 340 | W22Xd 355A/B | 1333 | 7,0 | 1,4 | 2,8 | 6,3 | 13 | 25 | 2300 | 81 | 1791 | 94,1 | 95,5 | 95,8 | 0,74 | 0,82 | 0,85 | 42,6 |
| 280 | 380 | W22Xd 355A/B | 1493 | 7,0 | 1,4 | 2,8 | 7,3 | 12 | 23 | 2750 | 81 | 1791 | 94,1 | 95,5 | 95,8 | 0,74 | 0,82 | 0,85 | 47,7 |
| 315 | 425 | W22Xd 355A/B | 1680 | 7,0 | 1,4 | 2,8 | 7,5 | 12 | 23 | 2900 | 81 | 1791 | 94,4 | 95,6 | 95,9 | 0,74 | 0,82 | 0,85 | 53,6 |
| 355 | 480 | W22Xd 355A/B | 1893 | 7,0 | 1,5 | 2,8 | 8,2 | 10 | 21 | 3050 | 81 | 1791 | 94,5 | 95,7 | 96,0 | 0,74 | 0,82 | 0,85 | 60,4 |
| 400 | 540 | W22Xd 355A/B | 2133 | 7,0 | 1,5 | 2,8 | 8,7 | 10 | 21 | 3250 | 81 | 1791 | 94,5 | 95,7 | 96,0 | 0,74 | 0,82 | 0,85 | 68,0 |
| 450 | 610 | W22Xd 400L/J | 2398 | 6,4 | 1,3 | 2,7 | 19,1 | 13 | 25 | 4200 | 85 | 1792 | 95,0 | 96,0 | 96,2 | 0,79 | 0,85 | 0,86 | 75,5 |
| 500 | 675 | W22Xd 400L/J | 2665 | 6,4 | 1,3 | 2,7 | 20,1 | 13 | 25 | 4350 | 85 | 1792 | 95,0 | 96,0 | 96,2 | 0,79 | 0,85 | 0,86 | 83,9 |
| 560 | 755 | W22Xd 400G (1) | 2986 | 5,8 | 0,5 | 2,6 | 23,2 | 20 | 40 | 5150 | 85 | 1791 | 95,8 | 96,3 | 96,5 | 0,81 | 0,87 | 0,88 | 91,5 |
| 630 | 850 | W22Xd 400G (1) | 3359 | 5,8 | 0,5 | 2,6 | 25,9 | 17 | 34 | 5350 | 85 | 1791 | 95,9 | 96,3 | 96,5 | 0,82 | 0,87 | 0,88 | 103 |
| 710 | 960 | W22Xd 450K/H (1) | 3782 | 6,0 | 0,7 | 2,5 | 25,2 | 18 | 36 | 6300 | 85 | 1793 | 96,3 | 96,7 | 96,8 | 0,79 | 0,85 | 0,87 | 117 |
| 800 | 1080 | W22Xd 450K/H (1) | 4261 | 6,0 | 0,7 | 2,5 | 26,7 | 17 | 34 | 6550 | 85 | 1793 | 96,6 | 96,9 | 97,0 | 0,79 | 0,85 | 0,87 | 132 |
| 900 | 1215 | W22Xd 450K/H (1) | 4794 | 6,0 | 0,7 | 2,5 | 28,2 | 17 | 34 | 6700 | 85 | 1793 | 96,5 | 97,0 | 97,1 | 0,79 | 0,85 | 0,87 | 148 |
| 1000 | 1350 | W22Xd 450K/H (1) | 5326 | 6,1 | 0,7 | 2,6 | 29,6 | 15 | 30 | 7000 | 85 | 1793 | 96,6 | 97,1 | 97,2 | 0,79 | 0,85 | 0,87 | 164 |
| 1120 | 1515 | W22Xd 500K/H (1) | 5962 | 6,0 | 0,6 | 2,3 | 61,1 | 14 | 28 | 10000 | 85 | 1794 | 96,8 | 97,2 | 97,3 | 0,84 | 0,88 | 0,89 | 179 |
| 1250 | 1690 | W22Xd 500K/H (1) | 6654 | 6,0 | 0,6 | 2,3 | 65,0 | 12 | 24 | 10250 | 85 | 1794 | 96,9 | 97,3 | 97,4 | 0,84 | 0,88 | 0,89 | 200 |
| 1400 | 1890 | W22Xd 500K/H (1) | 7453 | 6,0 | 0,6 | 2,3 | 69,4 | 10 | 20 | 10500 | 85 | 1794 | 96,9 | 97,4 | 97,5 | 0,84 | 0,88 | 0,89 | 224 |
| 1400 | 1890 | W22Xd 560H/G (1) | 7444 | 6,0 | 0,5 | 2,7 | 98,3 | 14 | 28 | 12360 | 91 | 1796 | 96,5 | 96,8 | 97,1 | 0,83 | 0,88 | 0,88 | 227 |
| 1600 | 2160 | W22Xd 560H/G (1) | 8508 | 6,0 | 0,5 | 2,7 | 103 | 12 | 24 | 12720 | 91 | 1796 | 96,5 | 97,0 | 97,2 | 0,83 | 0,88 | 0,88 | 260 |

W22Xd Rib-Cooled Series / Optional - Sleeve Bearings arrangement

| | | | | | | | | | | | | Y 4160V/60Hz | | | | | | |
|--------|----|-----------|---------------------|--------------------------------|--------------------------------|----------------------------------|-------------------------------|--|-------------|----------------------|-----|------------------|----|-----|--------------------|----|-----|--------------------|
| Output | | Frame IEC | T _n (Nm) | I _s /I _n | T _s /T _n | T _{max} /T _n | Inertia J (Kgm ²) | Allowable locked rotor time Hot/Cold (s) | Weight (Kg) | Sound Pressure dB(A) | RPM | % of full load | | | | | | I _n (A) |
| kW | HP | | | | | | | | | | | Efficiency η (%) | | | Power Factor Cos φ | | | |
| | | | | | | | | | | | | 50 | 75 | 100 | 50 | 75 | 100 | |

VI Pole - 1000 min⁻¹

| | | | | | | | | | | | | | | | | | | | |
|------|------|------------------|------|-----|-----|-----|------|----|----|-------|----|------|------|------|------|------|------|------|------|
| 90 | 120 | W22Xd 315L | 719 | 6,5 | 1,2 | 2,4 | 3,9 | 18 | 40 | 1750 | 74 | 1195 | 92,9 | 94,2 | 94,6 | 0,60 | 0,70 | 0,75 | 17,6 |
| 110 | 150 | W22Xd 315L | 879 | 6,5 | 1,2 | 2,4 | 4,3 | 18 | 40 | 1850 | 74 | 1195 | 92,9 | 94,2 | 94,6 | 0,60 | 0,70 | 0,75 | 21,5 |
| 132 | 180 | W22Xd 355M/L | 1057 | 6,0 | 1,4 | 2,2 | 6,2 | 15 | 36 | 2150 | 74 | 1193 | 93,8 | 94,8 | 95,0 | 0,65 | 0,75 | 0,80 | 24,1 |
| 160 | 215 | W22Xd 355M/L | 1281 | 6,0 | 1,4 | 2,2 | 6,4 | 14 | 34 | 2250 | 74 | 1193 | 94,1 | 95,1 | 95,3 | 0,65 | 0,75 | 0,80 | 29,1 |
| 200 | 270 | W22Xd 355A/B | 1601 | 6,0 | 1,4 | 2,2 | 7,7 | 13 | 32 | 2500 | 74 | 1193 | 94,3 | 95,3 | 95,5 | 0,65 | 0,75 | 0,80 | 36,3 |
| 250 | 340 | W22Xd 355A/B | 2001 | 6,0 | 1,4 | 2,2 | 9,3 | 12 | 30 | 2600 | 74 | 1193 | 94,5 | 95,5 | 95,7 | 0,65 | 0,75 | 0,80 | 45,3 |
| 280 | 380 | W22Xd 355A/B | 2241 | 6,2 | 1,5 | 2,3 | 10,0 | 12 | 30 | 2700 | 74 | 1193 | 94,6 | 95,6 | 95,8 | 0,65 | 0,75 | 0,80 | 50,7 |
| 315 | 425 | W22Xd 355A/B | 2522 | 6,5 | 1,5 | 2,3 | 10,8 | 11 | 28 | 2850 | 74 | 1193 | 94,6 | 95,6 | 95,8 | 0,65 | 0,75 | 0,80 | 57,0 |
| 355 | 480 | W22Xd 355A/B | 2842 | 6,5 | 1,5 | 2,3 | 11,6 | 10 | 26 | 3050 | 74 | 1193 | 94,9 | 95,7 | 95,8 | 0,65 | 0,75 | 0,80 | 64,3 |
| 400 | 540 | W22Xd 400L/J | 3207 | 6,5 | 0,9 | 2,3 | 22,9 | 15 | 32 | 4200 | 80 | 1191 | 95,6 | 96,1 | 96,1 | 0,73 | 0,81 | 0,83 | 69,6 |
| 450 | 610 | W22Xd 400G (1) | 3608 | 6,0 | 0,6 | 2,2 | 25,3 | 18 | 40 | 4550 | 80 | 1191 | 95,2 | 95,9 | 96,1 | 0,80 | 0,82 | 0,83 | 78,3 |
| 500 | 675 | W22Xd 400G (1) | 4009 | 6,0 | 0,6 | 2,2 | 28,0 | 15 | 33 | 4800 | 80 | 1191 | 95,2 | 95,9 | 96,1 | 0,80 | 0,82 | 0,83 | 87,0 |
| 560 | 755 | W22Xd 400G (1) | 4490 | 6,0 | 0,6 | 2,2 | 32,0 | 13 | 27 | 4850 | 80 | 1191 | 95,4 | 96,0 | 96,2 | 0,80 | 0,82 | 0,83 | 97,3 |
| 630 | 850 | W22Xd 400G (1) | 5052 | 6,2 | 0,7 | 2,3 | 33,5 | 11 | 22 | 4900 | 80 | 1191 | 95,4 | 96,1 | 96,2 | 0,80 | 0,82 | 0,83 | 110 |
| 710 | 960 | W22Xd 450K/H (1) | 5674 | 6,0 | 0,7 | 3,0 | 52,1 | 15 | 32 | 6600 | 81 | 1195 | 95,0 | 96,0 | 96,2 | 0,74 | 0,82 | 0,85 | 121 |
| 800 | 1080 | W22Xd 450K/H (1) | 6393 | 6,0 | 0,7 | 3,0 | 54,7 | 15 | 32 | 6800 | 81 | 1195 | 95,2 | 96,1 | 96,2 | 0,76 | 0,83 | 0,85 | 136 |
| 900 | 1215 | W22Xd 500K/H (1) | 7186 | 6,2 | 0,7 | 2,7 | 93,5 | 19 | 34 | 10400 | 85 | 1196 | 95,9 | 96,5 | 96,6 | 0,78 | 0,84 | 0,86 | 150 |
| 1000 | 1350 | W22Xd 500K/H (1) | 7985 | 6,1 | 0,7 | 2,7 | 105 | 19 | 34 | 10650 | 85 | 1196 | 95,9 | 96,5 | 96,6 | 0,78 | 0,84 | 0,86 | 167 |
| 1000 | 1350 | W22Xd 560H/G (1) | 7978 | 5,9 | 0,6 | 2,5 | 148 | 12 | 22 | 12180 | 87 | 1197 | 96,2 | 96,8 | 96,9 | 0,78 | 0,85 | 0,85 | 169 |
| 1120 | 1515 | W22Xd 560H/G (1) | 8936 | 5,9 | 0,6 | 2,5 | 164 | 11 | 20 | 12600 | 87 | 1197 | 96,2 | 96,8 | 96,9 | 0,78 | 0,85 | 0,85 | 189 |
| 1250 | 1690 | W22Xd 560H/G (1) | 9973 | 5,9 | 0,6 | 2,5 | 171 | 11 | 20 | 12960 | 87 | 1197 | 96,2 | 96,8 | 96,9 | 0,78 | 0,85 | 0,85 | 211 |

VIII Pole - 750 min⁻¹

| | | | | | | | | | | | | | | | | | | | |
|------|------|------------------|-------|-----|-----|-----|------|----|----|-------|----|-----|------|------|------|------|------|------|------|
| 90 | 120 | W22Xd 315L | 966 | 7,5 | 1,4 | 2,4 | 3,5 | 18 | 40 | 1950 | 70 | 890 | 88,7 | 91,0 | 91,7 | 0,50 | 0,63 | 0,71 | 19,2 |
| 110 | 150 | W22Xd 355M/L | 1183 | 6,8 | 1,3 | 2,4 | 6,9 | 18 | 40 | 2350 | 70 | 888 | 93,6 | 94,4 | 94,2 | 0,69 | 0,77 | 0,80 | 20,3 |
| 132 | 180 | W22Xd 355M/L | 1420 | 6,8 | 1,3 | 2,4 | 7,5 | 18 | 40 | 2440 | 70 | 888 | 94,0 | 94,6 | 94,3 | 0,71 | 0,78 | 0,80 | 24,3 |
| 160 | 215 | W22Xd 355A/B | 1721 | 6,8 | 1,3 | 2,4 | 8,1 | 18 | 40 | 2640 | 70 | 888 | 94,2 | 94,7 | 94,4 | 0,71 | 0,78 | 0,80 | 29,4 |
| 200 | 270 | W22Xd 400L/J (1) | 2146 | 5,0 | 0,6 | 2,1 | 31,7 | 18 | 40 | 3850 | 79 | 890 | 95,3 | 96,1 | 96,1 | 0,73 | 0,80 | 0,82 | 35,2 |
| 250 | 340 | W22Xd 400L/J (1) | 2683 | 5,0 | 0,6 | 2,1 | 35,2 | 18 | 40 | 4000 | 79 | 890 | 95,3 | 96,1 | 96,1 | 0,73 | 0,80 | 0,82 | 44,0 |
| 280 | 380 | W22Xd 400G (1) | 3004 | 5,0 | 0,6 | 2,1 | 36,9 | 17 | 38 | 4200 | 79 | 890 | 95,6 | 96,1 | 96,1 | 0,71 | 0,79 | 0,82 | 49,3 |
| 315 | 425 | W22Xd 400G (1) | 3380 | 5,0 | 0,6 | 2,1 | 38,1 | 17 | 38 | 4400 | 79 | 890 | 95,6 | 96,1 | 96,1 | 0,71 | 0,79 | 0,82 | 55,5 |
| 355 | 480 | W22Xd 400G (1) | 3809 | 5,0 | 0,6 | 2,1 | 39,2 | 17 | 38 | 4750 | 79 | 890 | 95,6 | 96,1 | 96,1 | 0,69 | 0,78 | 0,82 | 62,5 |
| 400 | 540 | W22Xd 400G (1) | 4292 | 5,0 | 0,6 | 2,1 | 41,5 | 17 | 38 | 5050 | 79 | 890 | 95,6 | 96,1 | 96,1 | 0,73 | 0,80 | 0,82 | 70,4 |
| 450 | 610 | W22Xd 400G (1) | 4829 | 5,0 | 0,6 | 2,1 | 43,5 | 17 | 38 | 5150 | 79 | 890 | 95,6 | 96,1 | 96,1 | 0,73 | 0,80 | 0,82 | 79,3 |
| 500 | 675 | W22Xd 450K/H (1) | 5365 | 5,2 | 0,6 | 2,4 | 53,8 | 18 | 40 | 6400 | 80 | 890 | 95,6 | 96,0 | 96,2 | 0,71 | 0,80 | 0,82 | 88,0 |
| 560 | 755 | W22Xd 450K/H (1) | 6009 | 5,2 | 0,6 | 2,4 | 56,5 | 18 | 40 | 6700 | 80 | 890 | 95,6 | 96,0 | 96,2 | 0,71 | 0,80 | 0,82 | 98,5 |
| 630 | 850 | W22Xd 450K/H (1) | 6760 | 5,2 | 0,6 | 2,4 | 60,1 | 17 | 38 | 7000 | 80 | 890 | 95,6 | 96,0 | 96,2 | 0,71 | 0,80 | 0,82 | 111 |
| 710 | 960 | W22Xd 500K/H (1) | 7568 | 5,5 | 0,8 | 2,4 | 133 | 18 | 40 | 10500 | 85 | 896 | 96,4 | 96,7 | 96,7 | 0,72 | 0,79 | 0,80 | 127 |
| 800 | 1080 | W22Xd 500K/H (1) | 8527 | 5,5 | 0,8 | 2,3 | 136 | 18 | 40 | 10600 | 85 | 896 | 96,5 | 96,7 | 96,7 | 0,73 | 0,80 | 0,80 | 144 |
| 800 | 1080 | W22Xd 560H/G (1) | 8527 | 6,0 | 0,6 | 3,0 | 170 | 17 | 38 | 12900 | 87 | 896 | 96,4 | 96,9 | 97,0 | 0,65 | 0,75 | 0,79 | 145 |
| 900 | 1215 | W22Xd 560H/G (1) | 9593 | 6,0 | 0,6 | 3,0 | 179 | 18 | 40 | 13260 | 87 | 896 | 96,5 | 97,0 | 97,1 | 0,66 | 0,76 | 0,80 | 161 |
| 1000 | 1350 | W22Xd 560H/G (1) | 10658 | 6,0 | 0,6 | 3,0 | 188 | 18 | 40 | 13680 | 87 | 896 | 96,5 | 97,0 | 97,1 | 0,66 | 0,76 | 0,80 | 179 |

(1) Copper rotor

T_n = Full load torque

I_s / I_n = Locked rotor current

T_s / T_n = Locked rotor torque

T_{max} / T_n = Breakdown torque

I_n = Full load current

Notes:

-The indicated values for sound pressure levels are @ 1m no load, with 3 dB(A) tolerance.

-All values are according to IEC 60034-1 Standard tolerances.

-This data can be changed without prior notice.

W22Xd Rib-Cooled Series / Optional - Sleeve Bearings arrangement

| Output | | Frame IEC | T_n (Nm) | I_s/I_n | T_s/T_n | T_{max}/T_n | Inertia J (Kgm ²) | Allowable locked rotor time Hot/Cold (s) | Weight (Kg) | Sound Pressure dB(A) | RPM | Y 6000V/50Hz | | | | | | I_n (A) |
|--------|----|-----------|------------|-----------|-----------|---------------|-------------------------------|--|-------------|----------------------|-----|-----------------------|----|-----|----------------------------|----|-----|-----------|
| kW | HP | | | | | | | | | | | % of full load | | | | | | |
| | | | | | | | | | | | | Efficiency η (%) | | | Power Factor Cos φ | | | |
| | | | | | | | | | | | | 50 | 75 | 100 | 50 | 75 | 100 | |

II Pole - 3000 min⁻¹

| | | | | | | | | | | | | | | | | | | | |
|------|------|------------------|------------|-----|-----|-----|------|----|----|------|----|------|------|------|------|------|------|------|------|
| 90 | 120 | W22Xd 315L | 289 | 6,7 | 1,5 | 2,5 | 1,3 | 7 | 15 | 1800 | 80 | 2978 | 91,5 | 93,6 | 94,5 | 0,70 | 0,81 | 0,86 | 10,7 |
| 110 | 150 | W22Xd 315L | 353 | 6,8 | 1,6 | 2,6 | 1,5 | 6 | 12 | 1850 | 80 | 2978 | 93,3 | 94,3 | 94,6 | 0,71 | 0,82 | 0,87 | 12,9 |
| 132 | 180 | W22Xd 315L | 423 | 6,8 | 1,6 | 2,6 | 1,6 | 6 | 12 | 1900 | 80 | 2978 | 93,9 | 94,6 | 94,7 | 0,72 | 0,82 | 0,87 | 15,4 |
| 160 | 215 | W22Xd 355M/L | 512 | 7,5 | 1,4 | 2,9 | 3,3 | 12 | 24 | 2100 | 80 | 2986 | 94,1 | 95,3 | 95,7 | 0,81 | 0,87 | 0,88 | 18,3 |
| 200 | 270 | W22Xd 355M/L | 640 | 7,5 | 1,4 | 2,9 | 3,7 | 10 | 20 | 2200 | 80 | 2986 | 94,5 | 95,5 | 95,9 | 0,81 | 0,86 | 0,88 | 22,8 |
| 250 | 340 | W22Xd 355A/B | 800 | 7,5 | 1,4 | 3,0 | 4,8 | 11 | 22 | 2600 | 80 | 2986 | 94,8 | 95,7 | 96,0 | 0,85 | 0,89 | 0,90 | 27,8 |
| 280 | 380 | W22Xd 355A/B | 896 | 7,5 | 1,4 | 3,0 | 5,1 | 10 | 20 | 2700 | 80 | 2986 | 95,0 | 95,9 | 96,2 | 0,85 | 0,89 | 0,90 | 31,1 |
| 315 | 425 | W22Xd 355A/B | 1007 | 7,5 | 1,5 | 3,0 | 5,4 | 9 | 18 | 2850 | 80 | 2986 | 95,1 | 96,0 | 96,3 | 0,84 | 0,88 | 0,90 | 35,0 |
| 355 | 480 | W22Xd 355A/B | 1135 | 7,5 | 1,5 | 3,1 | 5,8 | 8 | 16 | 3050 | 80 | 2986 | 95,3 | 96,1 | 96,4 | 0,83 | 0,88 | 0,90 | 39,4 |
| 400 | 540 | W22Xd 400L/J | 1279 | 6,5 | 1,5 | 2,6 | 9,9 | 8 | 16 | 4050 | 80 | 2986 | 95,5 | 96,3 | 96,6 | 0,82 | 0,87 | 0,88 | 45,3 |
| 450 | 610 | W22Xd 400L/J | 1439 | 6,5 | 1,5 | 2,6 | 10,2 | 7 | 14 | 4100 | 80 | 2986 | 95,9 | 96,6 | 96,8 | 0,83 | 0,87 | 0,88 | 50,8 |
| 500 | 675 | W22Xd 400L/J | 1599 | 6,7 | 1,7 | 2,8 | 10,8 | 6 | 12 | 4200 | 80 | 2986 | 95,9 | 96,7 | 97,0 | 0,81 | 0,86 | 0,88 | 56,4 |
| 560 | 755 | W22Xd 450K/H (1) | 1789 | 6,5 | 0,6 | 2,9 | 12,2 | 15 | 38 | 5980 | 80 | 2989 | 96,3 | 97,0 | 97,1 | 0,84 | 0,89 | 0,90 | 61,7 |
| 630 | 850 | W22Xd 450K/H (1) | 2013 | 6,5 | 0,6 | 2,9 | 12,9 | 15 | 36 | 6110 | 80 | 2989 | 96,4 | 97,1 | 97,2 | 0,84 | 0,89 | 0,90 | 69,3 |
| 710 | 960 | W22Xd 450K/H (1) | 2268 | 6,8 | 0,6 | 2,9 | 13,4 | 14 | 36 | 6240 | 80 | 2989 | 96,4 | 97,2 | 97,4 | 0,84 | 0,89 | 0,90 | 77,9 |
| 800 | 1080 | W22Xd 500K/H (1) | 2555 | 5,9 | 0,6 | 2,6 | 20,7 | 15 | 36 | 8800 | 82 | 2990 | 97,0 | 97,5 | 97,6 | 0,85 | 0,90 | 0,91 | 86,7 |
| 900 | 1215 | W22Xd 500K/H (1) | 2875 | 5,9 | 0,6 | 2,6 | 21,7 | 14 | 36 | 9000 | 82 | 2990 | 97,0 | 97,6 | 97,7 | 0,85 | 0,90 | 0,91 | 97,4 |
| 1000 | 1350 | W22Xd 500K/H (1) | 3193 | 6,1 | 0,7 | 2,8 | 23,2 | 10 | 26 | 9200 | 82 | 2991 | 97,2 | 97,7 | 97,8 | 0,85 | 0,90 | 0,91 | 108 |
| 1120 | 1515 | W22Xd 500K/H (1) | 3576 | 6,5 | 0,8 | 3,0 | 24,7 | 8 | 20 | 9650 | 82 | 2991 | 97,2 | 97,7 | 97,9 | 0,85 | 0,90 | 0,91 | 121 |
| 1120 | 1515 | W22Xd 560H/G (1) | On request | | | | | | | | | | | | | | | | |
| 1250 | 1690 | W22Xd 560H/G (1) | On request | | | | | | | | | | | | | | | | |

IV Pole - 1500 min⁻¹

| | | | | | | | | | | | | | | | | | | | |
|------|------|------------------|-------|-----|-----|-----|------|----|----|-------|----|------|------|------|------|------|------|------|------|
| 90 | 120 | W22Xd 315L | 579 | 6,7 | 1,2 | 2,5 | 2,6 | 20 | 40 | 1785 | 76 | 1484 | 93,0 | 94,2 | 94,5 | 0,70 | 0,80 | 0,83 | 11,0 |
| 110 | 150 | W22Xd 315L | 708 | 6,7 | 1,3 | 2,5 | 2,8 | 15 | 32 | 1825 | 76 | 1484 | 93,0 | 94,2 | 94,5 | 0,70 | 0,80 | 0,83 | 13,4 |
| 132 | 180 | W22Xd 315L | 849 | 6,7 | 1,3 | 2,5 | 3,1 | 15 | 32 | 1875 | 76 | 1484 | 93,0 | 94,2 | 94,6 | 0,70 | 0,80 | 0,83 | 16,1 |
| 160 | 215 | W22Xd 355M/L | 1025 | 6,7 | 1,5 | 2,9 | 5,4 | 18 | 39 | 2200 | 76 | 1491 | 94,5 | 95,5 | 95,8 | 0,73 | 0,81 | 0,84 | 19,1 |
| 200 | 270 | W22Xd 355M/L | 1281 | 6,7 | 1,5 | 2,9 | 6,3 | 16 | 34 | 2300 | 76 | 1491 | 95,1 | 95,9 | 96,1 | 0,73 | 0,81 | 0,84 | 23,8 |
| 250 | 340 | W22Xd 355A/B | 1601 | 7,2 | 1,5 | 2,9 | 7,3 | 11 | 23 | 2775 | 76 | 1491 | 95,1 | 95,9 | 96,1 | 0,71 | 0,80 | 0,84 | 29,9 |
| 280 | 380 | W22Xd 355A/B | 1793 | 7,2 | 1,5 | 2,9 | 7,5 | 10 | 21 | 2900 | 76 | 1491 | 95,4 | 96,1 | 96,2 | 0,73 | 0,82 | 0,84 | 33,3 |
| 315 | 425 | W22Xd 355A/B | 2018 | 7,2 | 1,6 | 2,9 | 8,2 | 9 | 19 | 3050 | 76 | 1491 | 95,4 | 96,2 | 96,3 | 0,72 | 0,81 | 0,84 | 37,5 |
| 355 | 480 | W22Xd 355A/B | 2274 | 7,2 | 1,6 | 2,9 | 8,7 | 9 | 19 | 3250 | 76 | 1491 | 95,4 | 96,2 | 96,3 | 0,71 | 0,80 | 0,84 | 42,2 |
| 400 | 540 | W22Xd 400L/J | 2559 | 6,5 | 1,4 | 2,8 | 19,1 | 12 | 28 | 4200 | 80 | 1493 | 95,0 | 96,0 | 96,3 | 0,77 | 0,84 | 0,86 | 46,5 |
| 450 | 610 | W22Xd 400L/J | 2878 | 6,5 | 1,4 | 2,8 | 20,1 | 11 | 25 | 4350 | 80 | 1493 | 95,1 | 96,1 | 96,4 | 0,77 | 0,84 | 0,86 | 52,2 |
| 500 | 675 | W22Xd 400L/J | 3198 | 6,5 | 1,4 | 2,8 | 21,3 | 10 | 23 | 4550 | 80 | 1493 | 95,4 | 96,3 | 96,6 | 0,77 | 0,84 | 0,86 | 57,9 |
| 560 | 755 | W22Xd 400G (1) | 3584 | 6,1 | 0,7 | 2,8 | 25,9 | 13 | 26 | 5350 | 80 | 1492 | 96,4 | 96,9 | 97,0 | 0,82 | 0,88 | 0,89 | 62,4 |
| 630 | 850 | W22Xd 450K/H (1) | 4030 | 6,0 | 0,7 | 2,5 | 25,5 | 15 | 32 | 6380 | 80 | 1493 | 96,7 | 97,1 | 97,2 | 0,79 | 0,85 | 0,87 | 71,7 |
| 710 | 960 | W22Xd 450K/H (1) | 4542 | 6,0 | 0,7 | 2,5 | 26,7 | 15 | 30 | 6560 | 80 | 1493 | 96,8 | 97,2 | 97,2 | 0,79 | 0,85 | 0,87 | 80,8 |
| 800 | 1080 | W22Xd 450K/H (1) | 5117 | 6,1 | 0,8 | 2,6 | 28,2 | 14 | 28 | 6700 | 80 | 1493 | 96,9 | 97,3 | 97,4 | 0,78 | 0,85 | 0,87 | 90,8 |
| 900 | 1215 | W22Xd 450K/H (1) | 5757 | 6,1 | 0,8 | 2,5 | 29,7 | 13 | 25 | 7000 | 80 | 1493 | 96,9 | 97,3 | 97,4 | 0,79 | 0,85 | 0,87 | 102 |
| 1000 | 1350 | W22Xd 500K/H (1) | 6388 | 6,0 | 0,6 | 2,3 | 61,1 | 13 | 27 | 10000 | 80 | 1495 | 96,9 | 97,4 | 97,5 | 0,84 | 0,88 | 0,89 | 111 |
| 1120 | 1515 | W22Xd 500K/H (1) | 7155 | 6,0 | 0,6 | 2,3 | 65,0 | 12 | 27 | 10250 | 80 | 1495 | 97,0 | 97,5 | 97,6 | 0,84 | 0,88 | 0,89 | 124 |
| 1250 | 1690 | W22Xd 500K/H (1) | 7985 | 6,1 | 0,6 | 2,3 | 69,4 | 11 | 25 | 10500 | 80 | 1495 | 97,1 | 97,6 | 97,7 | 0,83 | 0,88 | 0,89 | 138 |
| 1400 | 1890 | W22Xd 500K/H (1) | 8943 | 6,4 | 0,6 | 2,3 | 72,2 | 10 | 22 | 11000 | 80 | 1495 | 97,1 | 97,6 | 97,7 | 0,83 | 0,88 | 0,89 | 155 |
| 1400 | 1890 | W22Xd 560H/G (1) | 8937 | 6,0 | 0,5 | 2,7 | 98,3 | 12 | 22 | 12360 | 86 | 1496 | 97,1 | 97,6 | 97,7 | 0,82 | 0,87 | 0,88 | 157 |
| 1600 | 2160 | W22Xd 560H/G (1) | 10214 | 6,0 | 0,5 | 2,7 | 103 | 12 | 22 | 12720 | 86 | 1496 | 97,2 | 97,7 | 97,8 | 0,82 | 0,87 | 0,88 | 179 |



W22Xd Rib-Cooled Series / Optional - Sleeve Bearings arrangement

| Output | | Frame IEC | T _n (Nm) | I _s /I _n | T _s /T _n | T _{max} /T _n | Inertia J (Kgm ²) | Allowable locked rotor time Hot/Cold (s) | Weight (Kg) | Sound Pressure dB(A) | RPM | Y 6000V/50Hz | | | | | | I _n (A) |
|--------|----|-----------|---------------------|--------------------------------|--------------------------------|----------------------------------|-------------------------------|--|-------------|----------------------|-----|------------------|--|--|--------------------|--|--|--------------------|
| kW | HP | | | | | | | | | | | % of full load | | | | | | |
| | | | | | | | | | | | | Efficiency η (%) | | | Power Factor Cos φ | | | |
| | | 50 | 75 | 100 | 50 | 75 | 100 | | | | | | | | | | | |

VI Pole - 1000 min⁻¹

| | | | | | | | | | | | | | | | | | | | |
|------|------|------------------|-------|-----|-----|-----|------|----|----|-------|----|-----|------|------|------|------|------|------|------|
| 90 | 120 | W22Xd 315L | 864 | 6,7 | 1,2 | 2,4 | 4,2 | 18 | 40 | 1850 | 69 | 995 | 93,4 | 94,5 | 94,6 | 0,59 | 0,69 | 0,75 | 12,2 |
| 110 | 150 | W22Xd 315L | 1056 | 6,7 | 1,2 | 2,4 | 4,6 | 18 | 40 | 1950 | 69 | 995 | 93,6 | 94,6 | 94,7 | 0,59 | 0,69 | 0,75 | 14,9 |
| 132 | 180 | W22Xd 355M/L | 1269 | 6,0 | 1,3 | 2,3 | 6,9 | 20 | 40 | 2250 | 69 | 993 | 94,7 | 95,5 | 95,5 | 0,65 | 0,75 | 0,80 | 16,6 |
| 160 | 215 | W22Xd 355M/L | 1539 | 6,0 | 1,4 | 2,3 | 7,7 | 20 | 40 | 2350 | 69 | 993 | 94,9 | 95,5 | 95,6 | 0,65 | 0,75 | 0,80 | 20,1 |
| 200 | 270 | W22Xd 355A/B | 1923 | 6,3 | 1,5 | 2,3 | 9,3 | 20 | 40 | 2600 | 69 | 993 | 95,0 | 95,6 | 95,7 | 0,65 | 0,75 | 0,80 | 25,1 |
| 250 | 340 | W22Xd 355A/B | 2404 | 6,3 | 1,5 | 2,3 | 10,0 | 20 | 40 | 2700 | 69 | 993 | 95,1 | 95,7 | 95,7 | 0,65 | 0,75 | 0,80 | 31,4 |
| 280 | 380 | W22Xd 355A/B | 2693 | 6,3 | 1,5 | 2,3 | 10,8 | 19 | 38 | 2850 | 69 | 993 | 95,4 | 95,9 | 95,9 | 0,65 | 0,75 | 0,80 | 35,1 |
| 315 | 425 | W22Xd 355A/B | 3029 | 6,3 | 1,5 | 2,3 | 11,6 | 19 | 38 | 3050 | 69 | 993 | 95,5 | 96,0 | 96,0 | 0,66 | 0,75 | 0,80 | 39,5 |
| 355 | 480 | W22Xd 400L/J | 3421 | 6,2 | 1,0 | 2,3 | 22,9 | 16 | 35 | 4200 | 75 | 991 | 96,1 | 96,4 | 96,5 | 0,72 | 0,78 | 0,82 | 43,2 |
| 400 | 540 | W22Xd 400L/J | 3855 | 6,2 | 1,0 | 2,3 | 24,5 | 15 | 32 | 4400 | 75 | 991 | 96,2 | 96,6 | 96,5 | 0,73 | 0,80 | 0,82 | 48,6 |
| 450 | 610 | W22Xd 400G (1) | 4319 | 6,0 | 0,6 | 2,3 | 28,0 | 18 | 37 | 4800 | 75 | 995 | 95,6 | 96,0 | 96,2 | 0,81 | 0,82 | 0,83 | 54,2 |
| 500 | 675 | W22Xd 400G (1) | 4799 | 6,0 | 0,7 | 2,3 | 32,0 | 18 | 37 | 4850 | 75 | 995 | 95,5 | 96,0 | 96,2 | 0,80 | 0,82 | 0,83 | 60,3 |
| 560 | 755 | W22Xd 400G (1) | 5375 | 6,0 | 0,7 | 2,3 | 33,5 | 16 | 33 | 4900 | 75 | 995 | 95,9 | 96,2 | 96,4 | 0,80 | 0,82 | 0,83 | 67,3 |
| 630 | 850 | W22Xd 450K/H (1) | 6047 | 6,0 | 0,7 | 3,0 | 52,0 | 20 | 40 | 6600 | 76 | 995 | 96,1 | 96,8 | 97,0 | 0,73 | 0,81 | 0,85 | 73,5 |
| 710 | 960 | W22Xd 450K/H (1) | 6815 | 6,0 | 0,7 | 3,0 | 54,6 | 19 | 38 | 6800 | 76 | 995 | 96,3 | 96,9 | 97,1 | 0,74 | 0,82 | 0,85 | 82,8 |
| 800 | 1080 | W22Xd 500K/H (1) | 7663 | 6,0 | 0,7 | 2,7 | 93,5 | 19 | 37 | 10400 | 80 | 997 | 96,9 | 97,2 | 97,3 | 0,78 | 0,84 | 0,86 | 92,0 |
| 900 | 1215 | W22Xd 500K/H (1) | 8621 | 6,1 | 0,8 | 2,7 | 105 | 19 | 36 | 10650 | 80 | 997 | 96,9 | 97,2 | 97,3 | 0,78 | 0,85 | 0,86 | 103 |
| 900 | 1215 | W22Xd 560H/G (1) | 8621 | 6,0 | 0,6 | 2,5 | 148 | 19 | 39 | 11850 | 82 | 997 | 97,0 | 97,4 | 97,5 | 0,77 | 0,84 | 0,86 | 103 |
| 1000 | 1350 | W22Xd 560H/G (1) | 9579 | 6,0 | 0,6 | 2,5 | 155 | 18 | 37 | 12180 | 82 | 997 | 97,0 | 97,4 | 97,5 | 0,78 | 0,84 | 0,86 | 115 |
| 1120 | 1515 | W22Xd 560H/G (1) | 10728 | 6,0 | 0,6 | 2,6 | 164 | 18 | 37 | 12600 | 82 | 997 | 96,9 | 97,4 | 97,5 | 0,77 | 0,84 | 0,86 | 129 |
| 1250 | 1690 | W22Xd 560H/G (1) | 11973 | 6,0 | 0,6 | 2,6 | 172 | 15 | 32 | 12960 | 82 | 997 | 97,0 | 97,4 | 97,5 | 0,79 | 0,85 | 0,86 | 143 |

VIII Pole - 750 min⁻¹

| | | | | | | | | | | | | | | | | | | | |
|------|------|------------------|-------|-----|-----|-----|------|----|----|-------|----|-----|------|------|------|------|------|------|------|
| 90 | 120 | W22Xd 315L | 1158 | 7,5 | 1,4 | 2,4 | 3,8 | 17 | 37 | 2050 | 65 | 742 | 89,3 | 91,3 | 92,0 | 0,50 | 0,63 | 0,71 | 13,3 |
| 110 | 150 | W22Xd 355M/L | 1420 | 6,8 | 1,3 | 2,4 | 7,5 | 18 | 40 | 2450 | 65 | 740 | 94,0 | 94,5 | 94,5 | 0,69 | 0,77 | 0,80 | 14,0 |
| 132 | 180 | W22Xd 355A/B | 1704 | 6,8 | 1,3 | 2,4 | 8,1 | 18 | 40 | 2650 | 65 | 740 | 94,6 | 94,6 | 94,6 | 0,71 | 0,78 | 0,80 | 16,8 |
| 160 | 215 | W22Xd 355A/B | 2065 | 6,8 | 1,3 | 2,4 | 8,9 | 18 | 40 | 2950 | 65 | 740 | 94,8 | 95,0 | 94,7 | 0,71 | 0,78 | 0,80 | 20,3 |
| 200 | 270 | W22Xd 400L/J (1) | 2581 | 5,0 | 0,6 | 2,1 | 35,2 | 18 | 40 | 4000 | 74 | 740 | 95,7 | 96,2 | 96,4 | 0,73 | 0,80 | 0,82 | 24,3 |
| 250 | 340 | W22Xd 400G (1) | 3226 | 5,0 | 0,6 | 2,1 | 36,9 | 18 | 40 | 4500 | 74 | 740 | 95,7 | 96,2 | 96,4 | 0,71 | 0,79 | 0,82 | 30,4 |
| 280 | 380 | W22Xd 400G (1) | 3614 | 5,0 | 0,6 | 2,1 | 38,1 | 18 | 40 | 4700 | 74 | 740 | 95,7 | 96,2 | 96,4 | 0,71 | 0,79 | 0,82 | 34,1 |
| 315 | 425 | W22Xd 400G (1) | 4065 | 5,0 | 0,6 | 2,1 | 41,5 | 17 | 37 | 5050 | 74 | 740 | 95,8 | 96,3 | 96,4 | 0,71 | 0,79 | 0,82 | 38,3 |
| 355 | 480 | W22Xd 400G (1) | 4581 | 5,0 | 0,6 | 2,1 | 43,5 | 17 | 37 | 5150 | 74 | 740 | 95,8 | 96,3 | 96,4 | 0,69 | 0,78 | 0,82 | 43,2 |
| 400 | 540 | W22Xd 400G (1) | 5162 | 5,0 | 0,6 | 2,1 | 45,6 | 17 | 37 | 5200 | 74 | 740 | 95,9 | 96,4 | 96,4 | 0,73 | 0,80 | 0,82 | 48,7 |
| 450 | 610 | W22Xd 450K/H (1) | 5768 | 5,0 | 0,6 | 2,4 | 53,8 | 17 | 32 | 6400 | 75 | 745 | 95,8 | 96,4 | 96,5 | 0,69 | 0,79 | 0,82 | 54,7 |
| 500 | 675 | W22Xd 450K/H (1) | 6409 | 5,0 | 0,6 | 2,4 | 56,5 | 15 | 29 | 6700 | 75 | 745 | 95,8 | 96,4 | 96,5 | 0,71 | 0,80 | 0,82 | 60,8 |
| 560 | 755 | W22Xd 450K/H (1) | 7179 | 5,0 | 0,6 | 2,4 | 57,5 | 15 | 29 | 7000 | 75 | 745 | 95,8 | 96,4 | 96,5 | 0,71 | 0,79 | 0,82 | 68,1 |
| 630 | 850 | W22Xd 500K/H (1) | 8065 | 5,5 | 0,8 | 2,4 | 133 | 18 | 37 | 10500 | 80 | 746 | 96,7 | 97,0 | 97,0 | 0,73 | 0,80 | 0,80 | 78,1 |
| 710 | 960 | W22Xd 500K/H (1) | 9089 | 5,5 | 0,8 | 2,4 | 136 | 18 | 35 | 10600 | 80 | 746 | 96,7 | 97,0 | 97,0 | 0,72 | 0,79 | 0,80 | 88,0 |
| 710 | 960 | W22Xd 560H/G (1) | 9065 | 5,9 | 0,6 | 3,0 | 166 | 19 | 39 | 12420 | 82 | 748 | 96,7 | 97,2 | 97,2 | 0,66 | 0,76 | 0,80 | 87,9 |
| 800 | 1080 | W22Xd 560H/G (1) | 10214 | 5,9 | 0,6 | 3,0 | 175 | 18 | 37 | 12940 | 82 | 748 | 96,7 | 97,2 | 97,2 | 0,66 | 0,76 | 0,80 | 99,0 |
| 900 | 1215 | W22Xd 560H/G (1) | 11491 | 5,9 | 0,6 | 3,0 | 186 | 18 | 37 | 13540 | 82 | 748 | 96,8 | 97,3 | 97,3 | 0,66 | 0,76 | 0,80 | 111 |
| 1000 | 1350 | W22Xd 560H/G (1) | 12767 | 5,9 | 0,6 | 3,0 | 188 | 15 | 32 | 13680 | 82 | 748 | 96,9 | 97,4 | 97,4 | 0,66 | 0,76 | 0,80 | 123 |

(1) Copper rotor

T_n = Full load torque

I_s / I_n = Locked rotor current

T_s / T_n = Locked rotor torque

T_{max} / T_n = Breakdown torque

I_n = Full load current

Notes:

-The indicated values for sound pressure levels are @ 1m no load, with 3 dB(A) tolerance.

-All values are according to IEC 60034-1 Standard tolerances.

-This data can be changed without prior notice.

6.1.6. High Voltage - Electrical Data (6600V < U ≤ 11000V)

W22Xd Rib-Cooled Series / Optional - Sleeve Bearings arrangement

| Output | | Frame IEC | T _n (Nm) | I _s /I _n | T _s /T _n | T _{max} /T _n | Inertia J (Kgm ²) | Allowable locked rotor time Hot/Cold (s) | Weight (Kg) | Sound Pressure dB(A) | RPM | Y 10000V/50Hz | | | | | | |
|--------|----|-----------|---------------------|--------------------------------|--------------------------------|----------------------------------|-------------------------------|--|-------------|----------------------|-----|------------------|--|--|--------------------|--|--|--------------------|
| kW | HP | | | | | | | | | | | % of full load | | | | | | I _n (A) |
| | | | | | | | | | | | | Efficiency η (%) | | | Power Factor Cos φ | | | |
| | | 50 | 75 | 100 | 50 | 75 | 100 | | | | | | | | | | | |

II Pole - 3000 min⁻¹

| | | | | | | | | | | | | | | | | | | | |
|-----|------|------------------|------------|-----|-----|-----|------|----|----|-------|----|------|------|------|------|------|------|------|------|
| 355 | 480 | W22Xd 450K/H (1) | 1133 | 6,5 | 0,7 | 3,0 | 9,0 | 20 | 40 | 6150 | 80 | 2991 | 95,4 | 96,4 | 96,7 | 0,80 | 0,86 | 0,89 | 23,8 |
| 400 | 540 | W22Xd 450K/H (1) | 1277 | 6,5 | 0,7 | 3,0 | 9,5 | 18 | 36 | 6300 | 80 | 2991 | 95,7 | 96,6 | 96,8 | 0,81 | 0,87 | 0,89 | 26,8 |
| 450 | 610 | W22Xd 450K/H (1) | 1437 | 6,5 | 0,7 | 3,0 | 10,2 | 16 | 32 | 6550 | 80 | 2991 | 96,0 | 96,8 | 97,0 | 0,82 | 0,87 | 0,89 | 30,1 |
| 500 | 675 | W22Xd 450K/H (1) | 1596 | 6,5 | 0,7 | 3,0 | 11,1 | 15 | 30 | 7050 | 80 | 2991 | 96,1 | 96,9 | 97,1 | 0,83 | 0,88 | 0,90 | 33,0 |
| 560 | 755 | W22Xd 500K/H (1) | 1789 | 6,0 | 0,7 | 2,8 | 12,7 | 14 | 38 | 9600 | 82 | 2990 | 96,3 | 97,0 | 97,2 | 0,86 | 0,90 | 0,91 | 36,6 |
| 630 | 850 | W22Xd 500K/H (1) | 2012 | 6,0 | 0,7 | 2,8 | 13,5 | 12 | 32 | 10050 | 82 | 2990 | 96,4 | 97,1 | 97,3 | 0,86 | 0,90 | 0,91 | 41,1 |
| 710 | 960 | W22Xd 500K/H (1) | 2268 | 6,0 | 0,7 | 2,8 | 19,4 | 11 | 24 | 10250 | 82 | 2990 | 96,7 | 97,2 | 97,4 | 0,87 | 0,90 | 0,91 | 46,2 |
| 710 | 960 | W22Xd 560H/G (1) | On request | | | | | | | | | | | | | | | | |
| 800 | 1080 | W22Xd 560H/G (1) | On request | | | | | | | | | | | | | | | | |

IV Pole - 1500min⁻¹

| | | | | | | | | | | | | | | | | | | | |
|------|------|------------------|------|-----|-----|-----|------|----|----|-------|----|------|------|------|------|------|------|------|------|
| 355 | 480 | W22Xd 450K/H (1) | 2269 | 5,9 | 0,6 | 2,7 | 19,8 | 10 | 18 | 6010 | 80 | 1494 | 95,6 | 96,2 | 96,3 | 0,73 | 0,82 | 0,85 | 25,0 |
| 400 | 540 | W22Xd 450K/H (1) | 2557 | 5,9 | 0,6 | 2,7 | 20,2 | 10 | 18 | 6080 | 80 | 1494 | 95,7 | 96,3 | 96,4 | 0,74 | 0,82 | 0,85 | 28,2 |
| 450 | 610 | W22Xd 450K/H (1) | 2877 | 5,9 | 0,6 | 2,7 | 21,4 | 10 | 18 | 6200 | 80 | 1494 | 96,0 | 96,5 | 96,6 | 0,74 | 0,82 | 0,85 | 31,6 |
| 500 | 675 | W22Xd 450K/H (1) | 3196 | 6,0 | 0,6 | 2,7 | 23,2 | 10 | 18 | 6400 | 80 | 1494 | 96,1 | 96,6 | 96,7 | 0,74 | 0,82 | 0,85 | 35,1 |
| 560 | 755 | W22Xd 450K/H (1) | 3580 | 6,0 | 0,7 | 2,6 | 24,6 | 10 | 18 | 7200 | 80 | 1494 | 96,4 | 96,8 | 96,8 | 0,76 | 0,83 | 0,85 | 39,3 |
| 630 | 850 | W22Xd 500K/H (1) | 4027 | 6,1 | 0,7 | 2,6 | 47,2 | 12 | 22 | 9900 | 80 | 1494 | 96,4 | 96,9 | 97,1 | 0,83 | 0,88 | 0,88 | 42,6 |
| 710 | 960 | W22Xd 500K/H (1) | 4538 | 6,0 | 0,7 | 2,5 | 51,1 | 12 | 22 | 10400 | 80 | 1494 | 96,6 | 97,1 | 97,2 | 0,83 | 0,88 | 0,88 | 47,9 |
| 800 | 1080 | W22Xd 500K/H (1) | 5114 | 6,0 | 0,7 | 2,4 | 56,1 | 12 | 22 | 10930 | 80 | 1494 | 96,8 | 97,2 | 97,3 | 0,84 | 0,88 | 0,89 | 53,3 |
| 900 | 1215 | W22Xd 500K/H (1) | 5753 | 6,0 | 0,7 | 2,4 | 61,1 | 12 | 22 | 11450 | 80 | 1494 | 96,9 | 97,3 | 97,4 | 0,84 | 0,88 | 0,89 | 59,9 |
| 900 | 1215 | W22Xd 560H/G (1) | 5749 | 5,8 | 0,5 | 2,6 | 66,1 | 12 | 22 | 11450 | 86 | 1495 | 97,0 | 97,4 | 97,5 | 0,80 | 0,85 | 0,87 | 61,3 |
| 1000 | 1350 | W22Xd 560H/G (1) | 6388 | 5,8 | 0,5 | 2,6 | 69,4 | 12 | 22 | 11900 | 86 | 1495 | 97,1 | 97,5 | 97,6 | 0,81 | 0,86 | 0,87 | 68,0 |
| 1120 | 1515 | W22Xd 560H/G (1) | 7155 | 5,9 | 0,5 | 2,7 | 74,7 | 12 | 22 | 12200 | 86 | 1495 | 97,2 | 97,6 | 97,7 | 0,81 | 0,86 | 0,87 | 76,1 |

W22Xd Rib-Cooled Series / Optional - Sleeve Bearings arrangement

| | | | | | | | | | | | | | Y 1000V/50Hz | | | | | | |
|---------------------------------------|------|------------------|---------------------|--------------------------------|--------------------------------|----------------------------------|-------------------------------|--|-------------|----------------------|-----|------------------|--------------|------|--------------------|------|------|--------------------|------|
| Output | | Frame IEC | T _n (Nm) | I _s /I _n | T _s /T _n | T _{max} /T _n | Inertia J (Kgm ²) | Allowable locked rotor time Hot/Cold (s) | Weight (Kg) | Sound Pressure dB(A) | RPM | % of full load | | | | | | I _n (A) | |
| kW | HP | | | | | | | | | | | Efficiency η (%) | | | Power Factor Cos φ | | | | |
| | | | | | | | | | | | | 50 | 75 | 100 | 50 | 75 | 100 | | |
| VI Pole - 1000min⁻¹ | | | | | | | | | | | | | | | | | | | |
| 280 | 380 | W22Xd 450K/H (1) | 2687 | 5,5 | 0,7 | 3,1 | 36,9 | 20 | 40 | 6500 | 76 | 995 | 95,2 | 96,0 | 96,2 | 0,70 | 0,80 | 0,84 | 20,0 |
| 315 | 425 | W22Xd 450K/H (1) | 3023 | 5,5 | 0,7 | 3,1 | 39,3 | 18 | 35 | 6800 | 76 | 995 | 95,2 | 96,0 | 96,3 | 0,70 | 0,80 | 0,84 | 22,5 |
| 355 | 480 | W22Xd 450K/H (1) | 3407 | 5,5 | 0,7 | 3,1 | 39,7 | 16 | 31 | 7100 | 76 | 995 | 95,5 | 96,2 | 96,3 | 0,72 | 0,81 | 0,84 | 25,3 |
| 400 | 540 | W22Xd 450K/H (1) | 3839 | 5,5 | 0,7 | 3,1 | 40,2 | 13 | 25 | 7300 | 76 | 995 | 95,5 | 96,2 | 96,4 | 0,71 | 0,80 | 0,84 | 28,5 |
| 450 | 610 | W22Xd 450K/H (1) | 4319 | 5,5 | 0,7 | 3,1 | 41,6 | 12 | 23 | 7500 | 76 | 995 | 95,8 | 96,5 | 96,6 | 0,71 | 0,80 | 0,84 | 32,0 |
| 500 | 675 | W22Xd 500K/H (1) | 4794 | 5,7 | 0,7 | 2,5 | 56,4 | 17 | 34 | 11050 | 80 | 996 | 96,5 | 96,9 | 96,9 | 0,79 | 0,85 | 0,86 | 34,6 |
| 560 | 755 | W22Xd 500K/H (1) | 5369 | 5,7 | 0,7 | 2,5 | 59,1 | 14 | 27 | 11500 | 80 | 996 | 96,6 | 97,0 | 97,0 | 0,79 | 0,85 | 0,86 | 38,8 |
| 630 | 850 | W22Xd 500K/H (1) | 6041 | 5,9 | 0,7 | 2,5 | 64,5 | 12 | 23 | 12200 | 80 | 996 | 96,5 | 96,9 | 97,0 | 0,78 | 0,85 | 0,86 | 43,6 |
| 630 | 850 | W22Xd 560H/G (1) | 6035 | 6,0 | 0,7 | 2,5 | 97,2 | 13 | 24 | 12300 | 82 | 997 | 96,5 | 97,0 | 97,2 | 0,75 | 0,82 | 0,84 | 44,5 |
| 710 | 960 | W22Xd 560H/G (1) | 6801 | 6,0 | 0,7 | 2,5 | 102 | 11 | 21 | 12450 | 82 | 997 | 96,6 | 97,1 | 97,3 | 0,75 | 0,82 | 0,84 | 50,2 |
| 800 | 1080 | W22Xd 560H/G (1) | 7663 | 6,0 | 0,7 | 2,5 | 107 | 10 | 18 | 12900 | 82 | 997 | 96,7 | 97,2 | 97,3 | 0,75 | 0,82 | 0,84 | 56,5 |

| | | | | | | | | | | | | | | | | | | | |
|---|-----|------------------|------|-----|-----|-----|------|----|----|-------|----|-----|------|------|------|------|------|------|------|
| VIII Pole - 750 min⁻¹ | | | | | | | | | | | | | | | | | | | |
| 250 | 340 | W22Xd 450K/H (1) | 3200 | 5,5 | 0,7 | 2,7 | 34,9 | 20 | 40 | 6800 | 75 | 746 | 94,8 | 95,6 | 95,8 | 0,62 | 0,73 | 0,78 | 19,3 |
| 280 | 380 | W22Xd 450K/H (1) | 3584 | 5,5 | 0,7 | 2,7 | 36,9 | 18 | 36 | 7200 | 75 | 746 | 94,9 | 95,7 | 95,9 | 0,64 | 0,75 | 0,79 | 21,3 |
| 315 | 425 | W22Xd 450K/H (1) | 4033 | 5,5 | 0,7 | 2,7 | 39,4 | 16 | 32 | 7700 | 75 | 746 | 95,3 | 95,9 | 96,0 | 0,66 | 0,76 | 0,80 | 23,7 |
| 355 | 480 | W22Xd 450K/H (1) | 4545 | 5,5 | 0,7 | 2,7 | 40,2 | 13 | 26 | 7900 | 75 | 746 | 95,5 | 96,1 | 96,1 | 0,66 | 0,76 | 0,80 | 26,7 |
| 400 | 540 | W22Xd 500K/H (1) | 5121 | 5,3 | 0,8 | 2,3 | 113 | 18 | 36 | 11000 | 80 | 746 | 95,8 | 96,5 | 96,5 | 0,73 | 0,80 | 0,80 | 29,9 |
| 450 | 610 | W22Xd 500K/H (1) | 5761 | 5,5 | 0,8 | 2,4 | 118 | 16 | 32 | 11600 | 80 | 746 | 95,8 | 96,5 | 96,5 | 0,72 | 0,79 | 0,80 | 33,7 |
| 500 | 675 | W22Xd 500K/H (1) | 6401 | 5,7 | 0,8 | 2,4 | 132 | 16 | 32 | 12200 | 80 | 746 | 95,8 | 96,5 | 96,5 | 0,72 | 0,79 | 0,80 | 37,4 |
| 500 | 675 | W22Xd 560H/G (1) | 6384 | 5,7 | 0,6 | 3,0 | 155 | 16 | 32 | 12800 | 82 | 748 | 95,8 | 96,5 | 96,5 | 0,66 | 0,76 | 0,80 | 37,4 |
| 560 | 755 | W22Xd 560H/G (1) | 7150 | 5,7 | 0,6 | 3,0 | 163 | 14 | 28 | 13100 | 82 | 748 | 95,8 | 96,5 | 96,6 | 0,66 | 0,76 | 0,80 | 41,8 |

High voltage motors are also available on request for frame size 400.

(1) Copper rotor

T_n = Full load torque

I_s / I_n = Locked rotor current

T_s / T_n = Locked rotor torque

T_{max} / T_n = Breakdown torque

I_n = Full load current

Notes:

-The indicated values for sound pressure levels are @ 1m no load, with 3 dB(A) tolerance.

-All values are according to IEC 60034-1 Standard tolerances.

-This data can be changed without prior notice.

6.1.7. Medium Voltage - Mechanical Data (1100V < U ≤ 6600V) - Anti-friction bearings



W22Xd Rib-Cooled Series
315L - 355M/L, IMB3T
Standard - Anti-friction bearings

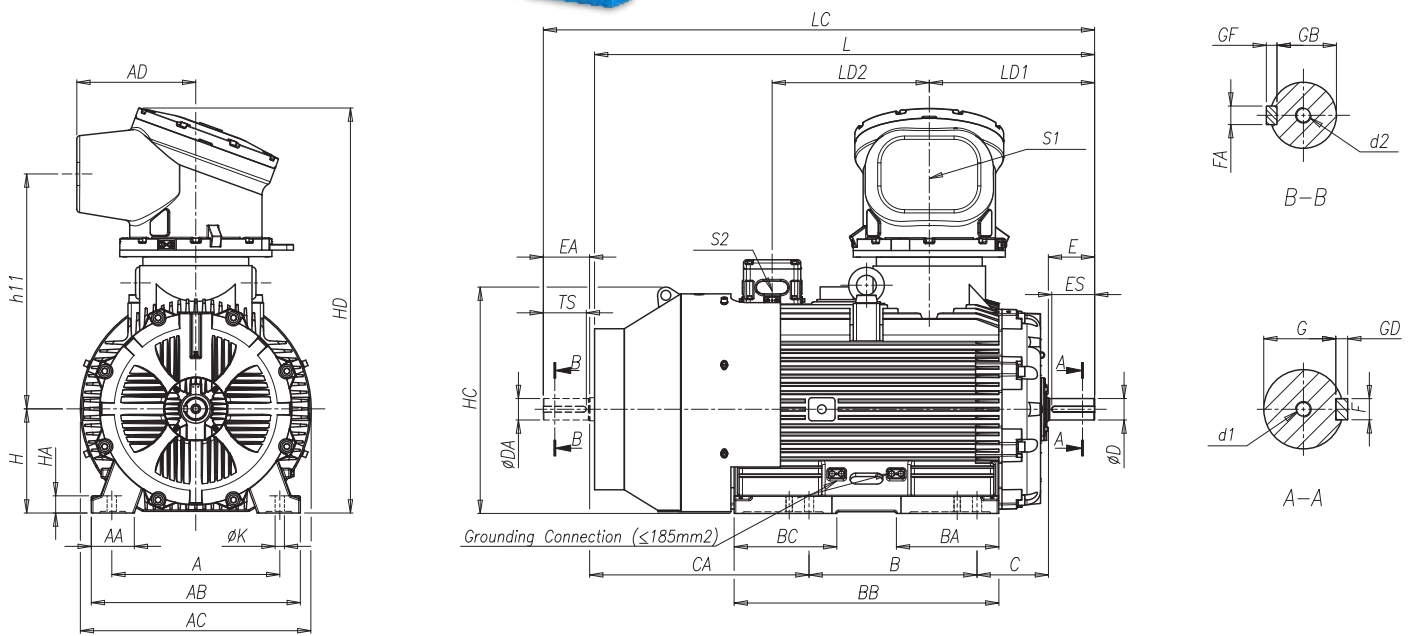

| Frame | Poles | A | AA | AB | AC | AD | BA | BB | BC | B | C | CA | H | HA | HC | HD | h11 | K | L | LC | LD1 | LD2 | | |
|--------|-------|-----|-----|-----|-----|-----|-----|-----|-----|-----|-----|-----|-----|-----|-----|------|------|----|------|------|------|------|------|-----|
| 315L | 2P | 508 | 130 | 632 | 698 | 360 | 310 | 800 | 310 | 508 | 216 | 663 | 315 | 52 | 684 | 1224 | 710 | 28 | 1512 | 1667 | 500 | 465 | | |
| | 4P+ | | | | | | | | | | | | | | | | | | | | 1542 | | 1697 | 530 |
| 355M/L | 2P | 610 | 130 | 730 | 780 | | | 315 | 830 | 315 | 560 | 254 | 567 | 355 | 55 | 765 | 1312 | | 758 | | 1576 | 1731 | 514 | 480 |
| | 4P+ | | | | | | | | | | 630 | | | | | | | | | | 1646 | 1831 | 584 | |

| Frame | Poles | Shaft dimensions | | | | | | | | | | | | | Bearings | | Power terminal box - S1 | Auxiliary terminal box - S2 | | | | |
|--------|-------|------------------|-----|-----|------|------|----|------|-----|-----|------|----|----|-------|----------|--------|-------------------------|---|-----------|--------|--|--|
| | | D | E | ES | F | G | GD | DA | EA | TS | FA | GB | GF | d1 | d2 | D.E. | N.D.E. | WTBX M | WTBX XS | | | |
| 315L | 2P | 65m6 | 140 | 125 | 18h9 | 58 | 11 | 60m6 | 140 | 125 | 18h9 | 53 | 11 | DSM20 | DSM20 | 6314C3 | 6314C3 | 1 ≤ 315A : 1xM63x1,5 315A < 1 ≤ 630A : 3xM63x1,5 | 3xM20x1,5 | | | |
| | 4P+ | 80m6 | 170 | 160 | 22h9 | 71 | 14 | 65m6 | | | | 58 | | | | 6319C3 | 6316C3 | | | | | |
| 355M/L | 2P | 75m6 | 140 | 125 | 20h9 | 67,5 | 12 | 60m6 | 140 | 125 | 18h9 | 53 | 11 | | | DSM20 | 6316C3 | | | 6316C3 | | |
| | 4P+ | 100m6 | 210 | 200 | 28h9 | 90 | 16 | 80m6 | 170 | 160 | 22h9 | 71 | 14 | | | DSM24 | 6322C3 | | | 6319C3 | | |

Notes:
 All the dimensions are in millimeters.
 Please, do not use these dimensions for construction. Certified drawings under request.
 External thrust shall be informed at the time of Inquiry/Order.
 Execution with second shaft end is optional and available under request.
 For other special executions please refer to us.
 The dimensions shown are subject to change without prior notice.



W22Xd Rib-Cooled Series
315L - 355M/L, IMV1
Standard - Anti-friction bearings

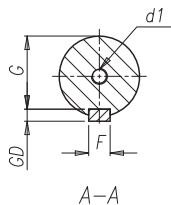
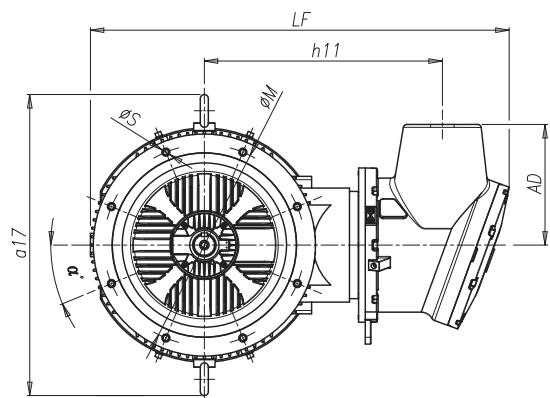

B

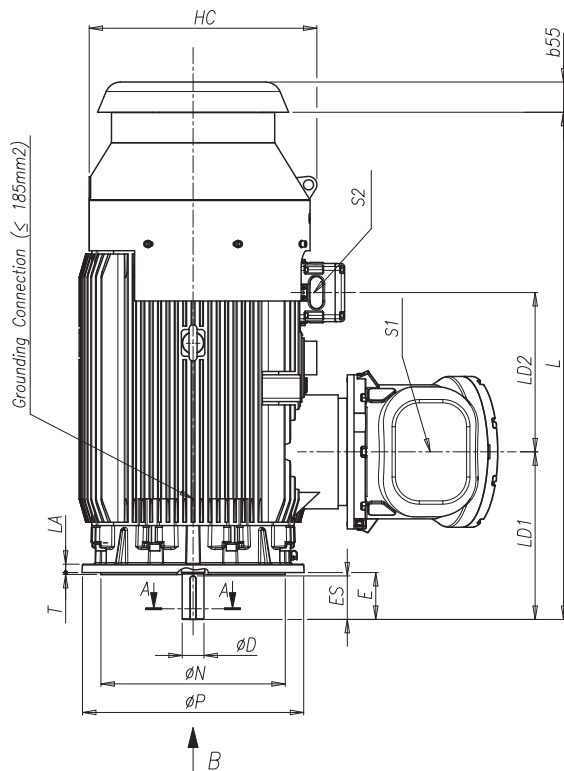

| Frame | Poles | AD | HC | h11 | L | LA | LD1 | LD2 | LF | b55 | a17 | M | N | P | T | S | Nr. Holes | α |
|--------|-------|-----|-----|-----|------|----|-----|-----|------|-----|-----|-----|-----|-----|---|----|-----------|-------|
| 315L | 2P | 360 | 679 | 710 | 1514 | 25 | 500 | 465 | 1249 | 91 | 898 | 600 | 550 | 660 | 6 | 24 | 8 | 22,5° |
| | 4P+ | | | | 1544 | | 530 | | | | | | | | | | | |
| 355M/L | 2P | | 759 | 758 | 1576 | 30 | 514 | 480 | 1357 | 93 | 988 | 740 | 680 | 800 | | | | |
| | 4P+ | | | | 1646 | | 584 | | | | | | | | | | | |

6

| Frame | Poles | Shaft dimensions | | | | | | | Bearings | | Power terminal box - S1 | Auxiliary terminal box - S2 |
|--------|-------|------------------|-----|-----|------|------|----|-------|----------|--------|---|-----------------------------|
| | | D | E | ES | F | G | GD | d1 | D.E. | N.D.E. | WTBX M | WTBX XS |
| 315L | 2P | 65m6 | 140 | 125 | 18h9 | 58 | 11 | DSM20 | 6314C3 | 6314C3 | I ≤ 315A : 1xM63x1,5 315A < I ≤ 630A : 3xM63x1,5 | 3xM20x1,5 |
| | 4P+ | 80m6 | 170 | 160 | 22h9 | 71 | 14 | DSM20 | 6319C3 | 6316C3 | | |
| 355M/L | 2P | 75m6 | 140 | 125 | 20h9 | 67,5 | 12 | DSM20 | 6316C3 | 6316C3 | | |
| | 4P+ | 100m6 | 210 | 200 | 28h9 | 90 | 16 | DSM24 | 6322C3 | 6319C3 | | |

Notes:

All the dimensions are in millimeters.
 Please, do not use these dimensions for construction. Certified drawings under request.
 External thrust shall be informed at the time of Inquiry/Order.
 For other special executions please refer to us.
 The dimensions shown are subject to change without prior notice.





W22Xd Rib-Cooled Series

355A/B - 400L/J - 400G, IMB3T
Standard - Anti-friction bearings

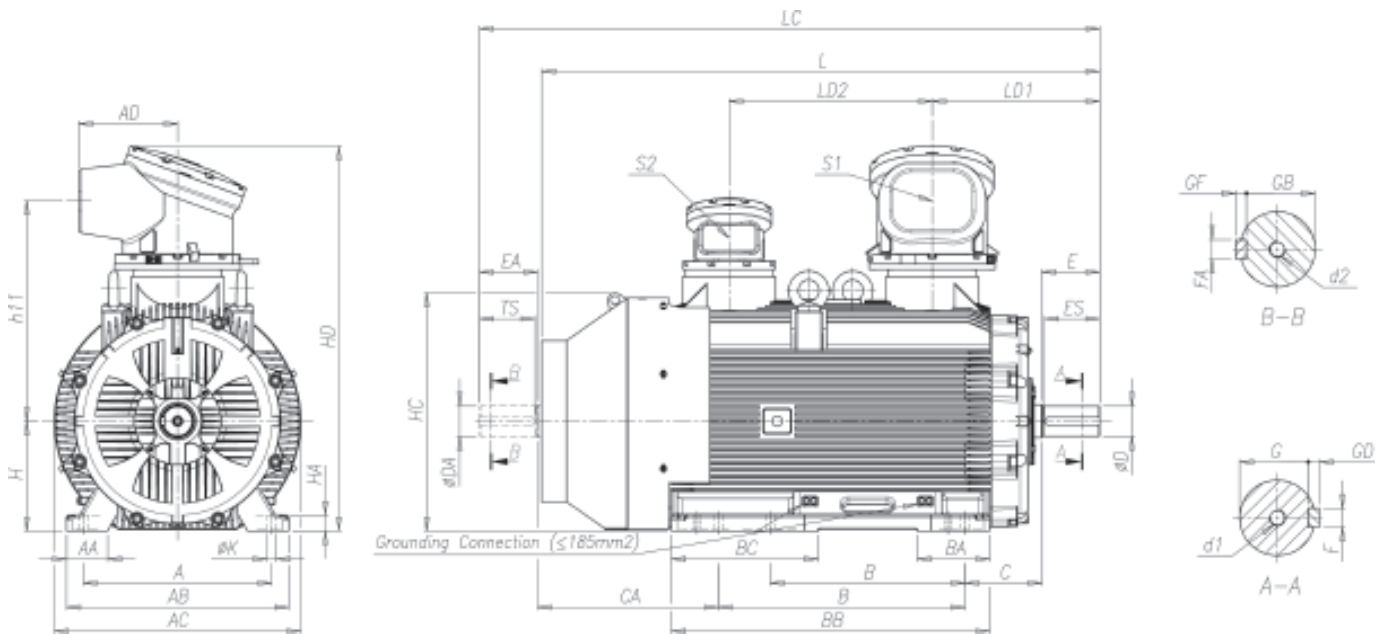

| Frame | Poles | A | AA | AB | AC | AD | BA | BB | BC | B | C | CA | H | HA | HC | HD | h11 | K | L | LC | LD1 | LD2 |
|--------|-------|-----|-----|-----|-----|-----|-----|------|-----|------------|-----|-----|-----|----|-----|------|-----|----|------|------|-----|-----|
| 355A/B | 2P | 610 | 130 | 730 | 780 | 360 | 225 | 1038 | 523 | 710 800 | 254 | 605 | 355 | 55 | 765 | 1312 | 758 | 28 | 1784 | 1939 | 514 | 618 |
| | 4P+ | | | | | | | | | | | | | | | | | | 1854 | 2039 | 584 | |
| 400L/J | 2P | 686 | 150 | 810 | 898 | 360 | 265 | 1160 | 535 | 710 900 | 280 | 659 | 400 | 58 | 867 | 1402 | 803 | 35 | 1994 | 2149 | 570 | 740 |
| | 4P+ | | | | | | | | | | | | | | | | | | 2034 | 2219 | 610 | |
| 400G | 2P | 686 | 150 | 810 | 898 | 360 | 420 | 1400 | 420 | 1120 | 280 | 679 | 400 | 58 | 867 | 1402 | 803 | 35 | 2234 | 2389 | 570 | 980 |
| | 4P+ | | | | | | | | | | | | | | | | | | 2274 | 2459 | 610 | |

| Frame | Poles | Shaft dimensions | | | | | | | | | | | | Bearings | | Power terminal box - S1 | Auxiliary terminal box - S2 | | |
|--------|-------|------------------|-----|-----|------|------|----|------|-----|-----|------|----|----|----------|-------|-------------------------|-----------------------------|--|-----------|
| | | D | E | ES | F | G | GD | DA | EA | TS | FA | GB | GF | d1 | d2 | D.E. | N.D.E. | WTBX M | WTBX S |
| 355A/B | 2P | 75m6 | 140 | 125 | 20h9 | 67,5 | 12 | 60m6 | 140 | 125 | 18h9 | 53 | 11 | DSM20 | DSM20 | 6316C3 | 6316C3 | I ≤ 315A : 1xM63x1,5 315A < I ≤ 630A : 3xM63x1,5 | 3xM20x1,5 |
| | 4P+ | 100m6 | 210 | 200 | 28h9 | 90 | 16 | 80m6 | 170 | 160 | 22h9 | 71 | 14 | DSM24 | | 6322C3 | 6319C3 | | |
| 400L/J | 2P | 80m6 | 170 | 160 | 22h9 | 71 | 14 | 60m6 | 140 | 125 | 18h9 | 53 | 11 | DSM20 | | 6318C3 | 6318C3 | | |
| | 4P+ | 110m6 | 210 | 200 | 28h9 | 100 | 16 | 80m6 | 170 | 160 | 22h9 | 71 | 14 | DSM24 | | 6324C3 | 6324C3 | | |
| 400G | 2P | 80m6 | 170 | 160 | 22h9 | 71 | 14 | 60m6 | 140 | 125 | 18h9 | 53 | 11 | DSM20 | | 6318C3 | 6318C3 | | |
| | 4P+ | 110m6 | 210 | 200 | 28h9 | 100 | 16 | 80m6 | 170 | 160 | 22h9 | 71 | 14 | DSM24 | | 6324C3 | 6324C3 | | |

Notes:
 All the dimensions are in millimeters.
 Please, do not use these dimensions for construction. Certified drawings under request.
 External thrust shall be informed at the time of Inquiry/Order.
 Execution with second shaft end is optional and available under request.
 For other special executions please refer to us.
 The dimensions shown are subject to change without prior notice.

W22Xd Rib-Cooled Series

355A/B - 400L/J - 400G, IMV1
Standard - Anti-friction bearings

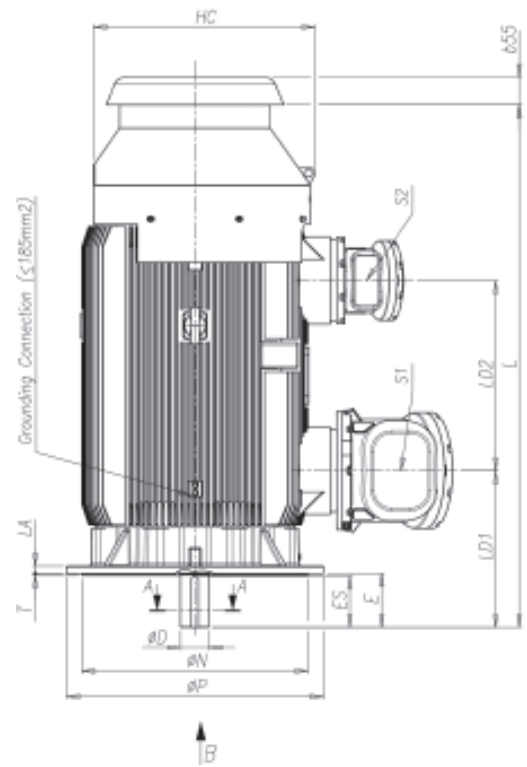
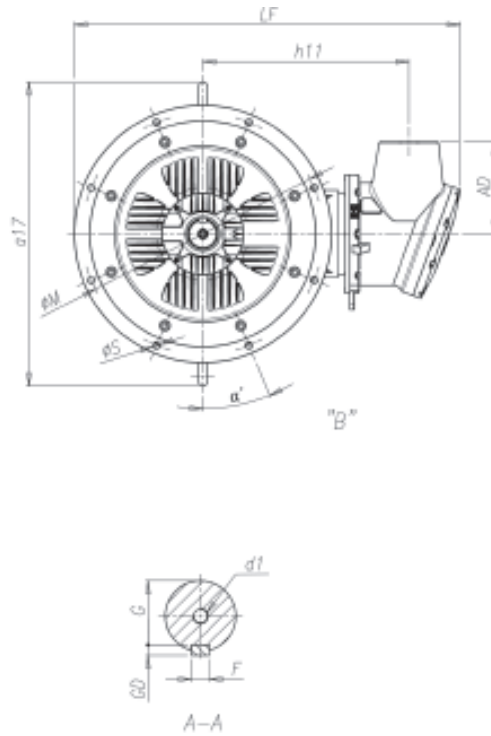

| Frame | Poles | AD | HC | h11 | L | LA | LD1 | LD2 | LF | b55 | a17 | M | N | P | T | S | Nr. Holes | α | |
|--------|-------|------|------|-----|------|-----|-----|-----|------|------|------|------|-----|------|----|------|-----------|-------|----|
| 355A/B | 2P | 360 | 759 | 758 | 1784 | 30 | 514 | 618 | 1357 | 93 | 988 | 740 | 680 | 800 | 6 | 24 | 8 | 22,5° | |
| | 4P+ | | | | 1854 | | 584 | | | | | | | | | | | | |
| 400L/J | 2P | | 1994 | 862 | 803 | 570 | 28 | 610 | 740 | 1503 | 106 | 1184 | 940 | 880 | | 1000 | | | 28 |
| | 4P+ | | 2034 | | | 610 | | | | | | | | | | | | | |
| 400G | 2P | 2234 | 862 | 803 | 570 | 28 | 610 | 980 | 1503 | 106 | 1184 | 940 | 880 | 1000 | 28 | | | | |
| | 4P+ | 2274 | | | 610 | | | | | | | | | | | | | | |

6

| Frame | Poles | Shaft dimensions | | | | | | | Bearings | | Power terminal box - S1 | Auxiliary terminal box - S2 |
|--------|-------|------------------|-----|-----|------|------|----|-------|----------|--------|---|-----------------------------|
| | | D | E | ES | F | G | GD | d1 | D.E. | N.D.E. | WTBX M | WTBX S |
| 355A/B | 2P | 75m6 | 140 | 125 | 20h9 | 67,5 | 12 | DSM20 | 6316C3 | 7316 | I ≤ 315A : 1xM63x1,5 315A < I ≤ 630A : 3xM63x1,5 | 3xM20x1,5 |
| | 4P+ | 100m6 | 210 | 200 | 28h9 | 90 | 16 | DSM24 | 6322C3 | 7319 | | |
| 400L/J | 2P | 80m6 | 170 | 160 | 22h9 | 71 | 14 | DSM20 | 6318C3 | 7318 | | |
| | 4P+ | 110m6 | 210 | 200 | 28h9 | 100 | 16 | DSM24 | 6324C3 | 7324 | | |
| 400G | 2P | 80m6 | 170 | 160 | 22h9 | 71 | 14 | DSM20 | 6318C3 | 7318 | | |
| | 4P+ | 110m6 | 210 | 200 | 28h9 | 100 | 16 | DSM24 | 6324C3 | 7324 | | |

Notes:

All the dimensions are in millimeters.
Please, do not use these dimensions for construction. Certified drawings under request.
External thrust shall be informed at the time of Inquiry/Order.
For other special executions please refer to us.
The dimensions shown are subject to change without prior notice.

W22Xd Rib-Cooled Series

450K/H - 500K/H - 560H/G, IMB3T
Standard - Anti-friction bearings

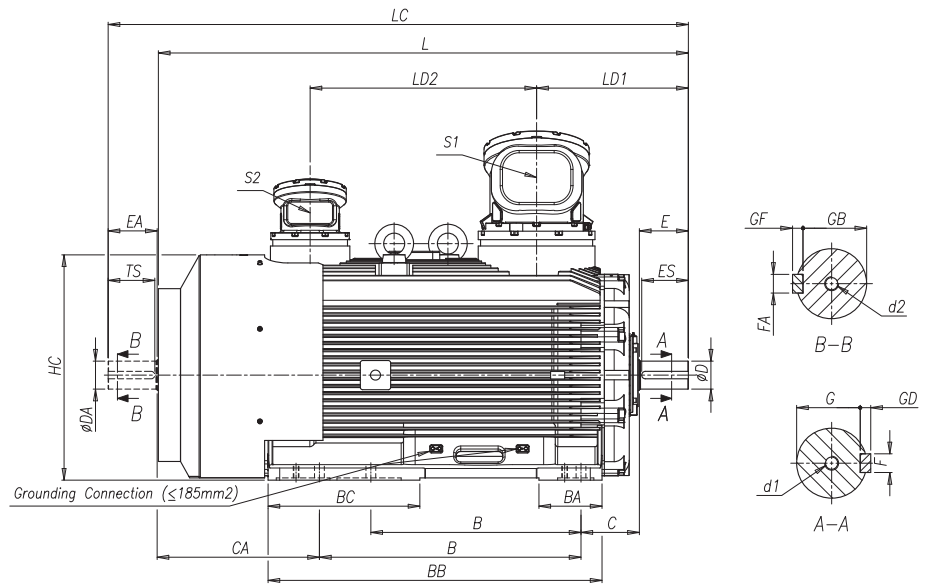
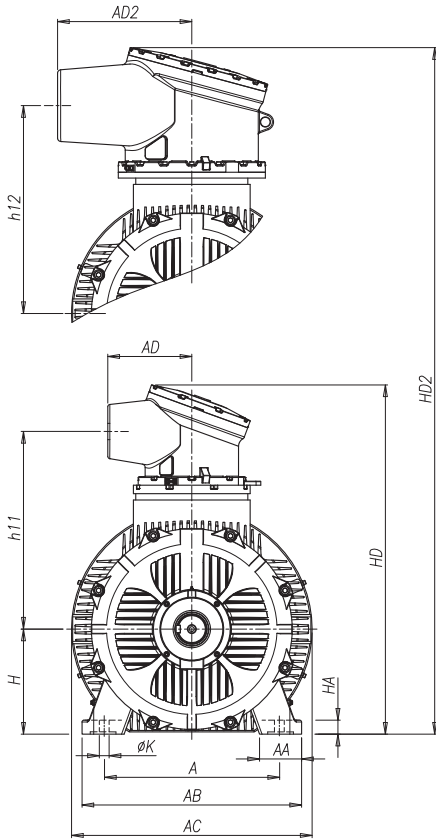

| Frame | Poles | A | AA | AB | AC | AD ⁽¹⁾ | BA | BB | BC | B | C | CA | H | HA | HC | HD ⁽¹⁾ | h11 ⁽¹⁾ | K | L | LC | LD1 | LD2 | | | |
|--------|-------|------|-----|------|------|-------------------|-----|------|-----|------|-----|------|-----|----|------|-------------------|--------------------|----|------|------|------|------|------|-----|------|
| 450K/H | 2P | 750 | 180 | 940 | 1030 | 360 | 270 | 1430 | 650 | 900 | 250 | 705 | 450 | 60 | 965 | 1495 | 846 | 42 | 2230 | 2385 | 610 | 970 | | | |
| | 4P+ | | | | | | | | | | | | | | | | | | | | | | | | |
| 500K/H | 2P | 850 | 200 | 1020 | 1162 | | 375 | 1800 | 915 | 1000 | 280 | 1065 | 500 | 65 | 1081 | 1565 | 866 | | 2750 | 2905 | 650 | 2830 | 3055 | 730 | 1300 |
| | 4P+ | | | | | | | | | | | | | | | | | | | | | | | | |
| 560H/G | 4P+ | 1000 | 220 | 1150 | 1324 | | | | | 600 | | 715 | 560 | 70 | 1225 | 1710 | 951 | | | 2830 | 3055 | 730 | | | |

| Frame | Poles | Shaft dimensions | | | | | | | | | | | | Bearings | | Power terminal box - S1 ⁽¹⁾ | Auxiliary terminal box - S2 | | |
|--------|-------|------------------|-----|-----|------|-----|----|-------|-----|-----|------|------|----|----------|-------|--|-----------------------------|---|-----------|
| | | D | E | ES | F | G | GD | DA | EA | TS | FA | GB | GF | d1 | d2 | D.E. | N.D.E. | WTBX M | WTBX S |
| 450K/H | 2P | 85m6 | 170 | 160 | 22h9 | 76 | 14 | 75m6 | 140 | 125 | 20h9 | 67,5 | 12 | DSM20 | DSM20 | 6318C3 | NU218C3 | I ≤ 315A : 1xM63x1,5 315A < I ≤ 630A : 3xM63x1,5 | 3xM20x1,5 |
| | 4P+ | 120m6 | 210 | 200 | 32h9 | 109 | 18 | 100m6 | 210 | 200 | 28h9 | 90 | 16 | DSM24 | DSM24 | 6326C3 | 6326C3 | | |
| 500K/H | 2P | 90m6 | 170 | 160 | 25h9 | 81 | 14 | 75m6 | 140 | 125 | 20h9 | 67,5 | 12 | DSM24 | DSM20 | NU220C3 + 6020C3 | NU220C3 | | |
| | 4P+ | 130m6 | 250 | 240 | 32h9 | 119 | 18 | 110m6 | 210 | 200 | 28h9 | 100 | 16 | | DSM24 | DSM24 | 6328C3 | | |
| 560H/G | 4P+ | 130m6 | 250 | 240 | 32h9 | 119 | 18 | 110m6 | 210 | 200 | 28h9 | 100 | 16 | DSM24 | DSM24 | NU328C3 + 6328C3 | NU328C3 | | |

| Frame | Poles | I > 630A | | | Power terminal box - WTBX-L - S1 |
|--------|-------|----------|------|-----|----------------------------------|
| | | AD2 | HD2 | h12 | |
| 450K/H | 2P | 575 | 1588 | 890 | 630A < I ≤ 1260A : 6xM63x1,5 |
| | 4P+ | | | | |
| 500K/H | 2P | | 1658 | 910 | |
| | 4P+ | | | | |
| 560H/G | 4P+ | | 1803 | 995 | |

Notes:
 (1) I ≤ 630A
 All the dimensions are in millimeters.
 Please, do not use these dimensions for construction. Certified drawings under request.
 External thrust shall be informed at the time of Inquiry/Order.
 Execution with second shaft end is optional and available under request.
 For other special executions please refer to us.
 The dimensions shown are subject to change without prior notice.

W22Xd Rib-Cooled Series

450K/H - 500K/H - 560H/G, IMV1
Standard - Anti-friction bearings

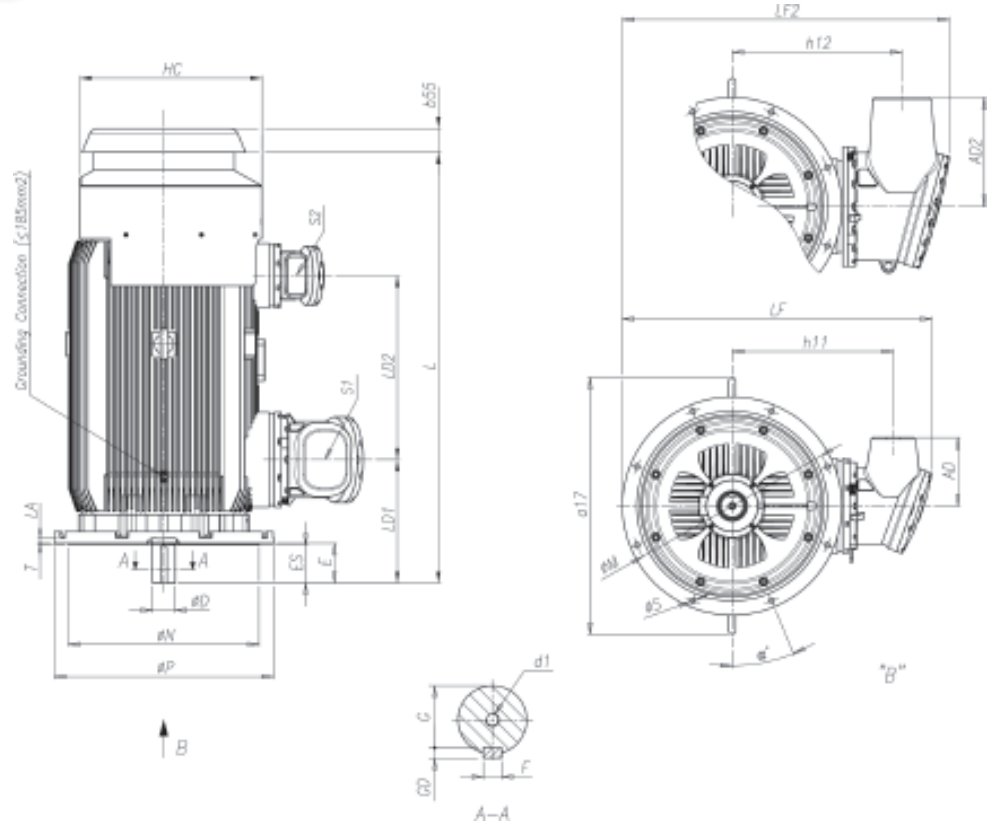

| Frame | Poles | AD ⁽¹⁾ | HC | h11 | L | LA | LD1 | LD2 | LF ⁽¹⁾ | b55 | a17 | M | N | P | T | S | Nr. Holes | α |
|--------|-------|-------------------|------|-----|------|----|------|------|-------------------|------|------|------|------|------|---|----|-----------|----------|
| 450K/H | 4P+ | 360 | 955 | 846 | 2270 | 30 | 650 | 970 | 1620 | 125 | 1352 | 1080 | 1000 | 1150 | 6 | 28 | 8 | 22,5° |
| 500K/H | 4P+ | | 1072 | 866 | | | 1640 | 1482 | 7 | | | | | | | | | |
| 560H/G | 4P+ | | 1215 | 951 | 2830 | | 730 | 1300 | 1772 | 1630 | 1180 | 1120 | 1250 | | | | | |

| Frame | Poles | Shaft dimensions | | | | | | | Bearings | | Power terminal box - S1 ⁽¹⁾ | | Auxiliary terminal box - S2 |
|--------|-------|------------------|-----|-----|------|---------|----|-------|----------|--------|---|--------|-----------------------------|
| | | D | E | ES | F | G | GD | d1 | D.E. | N.D.E. | WTBX M | WTBX S | |
| 450K/H | 4P+ | 120m6 | 210 | 200 | 32h9 | 109 | 18 | DSM24 | 6326 C3 | 7326 | I ≤ 315A : 1xM63x1,5 315A < I ≤ 630A : 3xM63x1,5 | | 3xM20x1,5 |
| 500K/H | 4P+ | 130m6 | 250 | 240 | | 119 | | | 6328 C3 | 7328 | | | |
| 560H/G | 4P+ | | | | | 6328 C3 | | | 7328 | | | | |

| Frame | Poles | I > 630A | | | Power terminal box - WTBX L - S1 |
|--------|-------|----------|------|-----|----------------------------------|
| | | AD2 | LF2 | h12 | |
| 450K/H | 4P+ | 575 | 1713 | 890 | 630A < I ≤ 1260A : 6xM63x1,5 |
| 500K/H | 4P+ | | 1733 | 910 | |
| 560H/G | 4P+ | | 1868 | 995 | |

Notes:

(1) I ≤ 630A
All the dimensions are in millimeters.
Please, do not use these dimensions for construction. Certified drawings under request.
External thrust shall be informed at the time of Inquiry/Order.
Execution with second shaft end is optional and available under request.
For other special executions please refer to us.
The dimensions shown are subject to change without prior notice.

6.1.8. Medium Voltage - Mechanical Data (1100V < U ≤ 6600V) - Sleeve Bearings



W22Xd Rib-Cooled Series

315L - 355M/L, IMB3T
Optional - Sleeve bearings

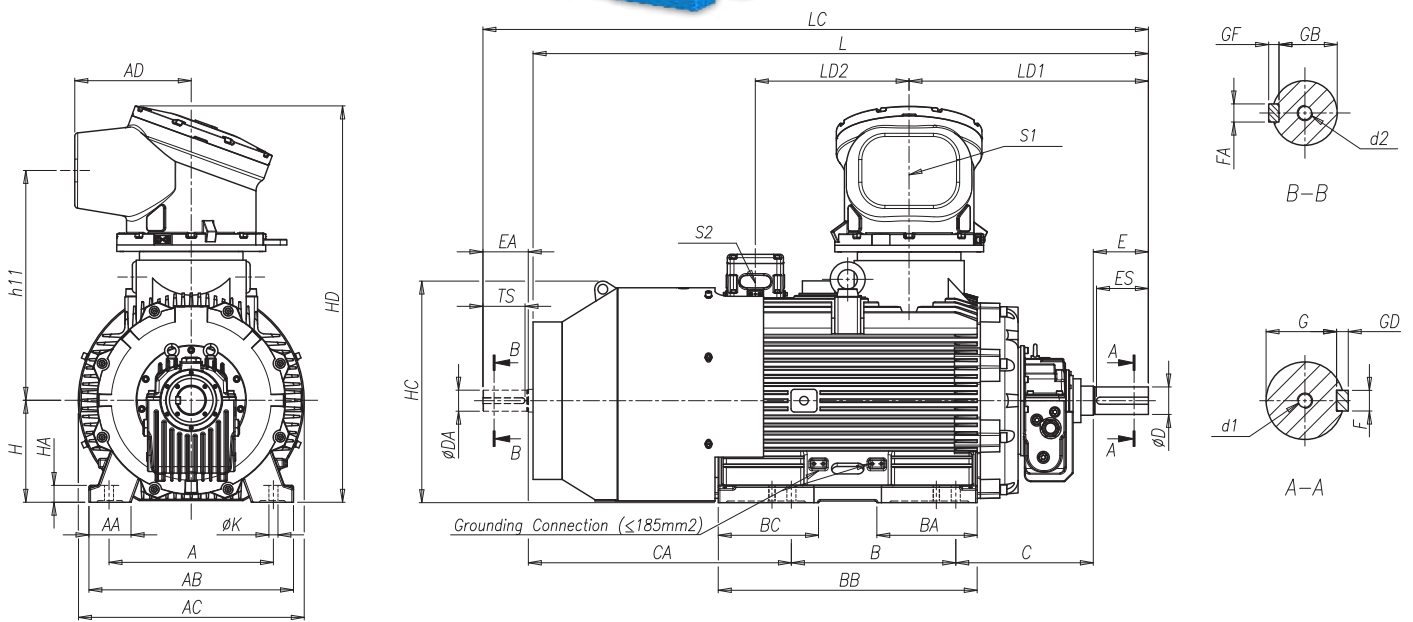

| Frame | Poles | A | AA | AB | AC | AD | BA | BB | BC | B | C | CA | H | HA | HC | HD | h11 | K | L | LC | LD1 | LD2 |
|--------|-------|-----|-----|-----|-----|-----|-----|-----|-----|-----|-----|-----|-----|-----|------|------|-----|------|------|------|-----|-----|
| 315L | 2P | 508 | 130 | 632 | 698 | 360 | 310 | 800 | 310 | 508 | 450 | 786 | 315 | 52 | 684 | 1224 | 710 | 28 | 1869 | 2024 | 734 | 465 |
| | 4P+ | | | | | | | | | | 475 | | | | | | | | 1924 | 2079 | 790 | |
| 355M/L | 2P | 610 | 130 | 730 | 780 | 360 | 315 | 830 | 315 | 560 | 693 | 355 | 55 | 765 | 1312 | 758 | 28 | 1923 | 2078 | 735 | 480 | |
| | 4P+ | | | | | | | | | 630 | | | | | | | | 500 | 2018 | 2203 | | 830 |

| Frame | Poles | Shaft dimensions | | | | | | | | | | | | | | Sleeve Bearings | | Power terminal box - S1 | Auxiliary terminal box - S2 | | |
|--------|-------|------------------|-----|-----|------|------|----|------|-----|-----|------|----|----|-------|----|-----------------|--------------|---|-----------------------------|---|-----------|
| | | D | E | ES | F | G | GD | DA | EA | TS | FA | GB | GF | d1 | d2 | D.E. | N.D.E. | WTBX M | WTBX XS | | |
| 315L | 2P | 65m6 | 140 | 125 | 18h9 | 58 | 11 | 60m6 | | | | 53 | | DSM20 | | EFNLB 9-80 | EFNLQ 9-80 | 1 ≤ 315A : 1xM63x1,5 315A < 1 ≤ 630A : 3xM63x1,5 | 3xM20x1,5 | | |
| | 4P+ | 80m6 | 170 | 160 | 22h9 | 71 | 14 | 65m6 | 140 | 125 | 18h9 | 58 | 11 | | | DSM20 | EFNLB 11-110 | | | EFNLQ 11-110 | |
| 355M/L | 2P | 75m6 | 140 | 125 | 20h9 | 67,5 | 12 | 60m6 | 140 | 125 | 18h9 | 53 | 11 | DSM20 | | EFNLB 9-80 | EFNLQ 9-80 | | | 1 ≤ 315A : 1xM63x1,5 315A < 1 ≤ 630A : 3xM63x1,5 | 3xM20x1,5 |
| | 4P+ | 100m6 | 210 | 200 | 28h9 | 90 | 16 | 80m6 | 170 | 160 | 22h9 | 71 | 14 | DSM24 | | EFNLB 11-110 | EFNLQ 11-110 | | | | |

Notes:
 All the dimensions are in millimeters.
 Please, do not use these dimensions for construction. Certified drawings under request.
 External thrust shall be informed at the time of Inquiry/Order.
 Execution with second shaft end is optional and available under request.
 For other special executions please refer to us.
 The dimensions shown are subject to change without prior notice.
 Rotor is not self-aligned, customer must ensure alignment.
 Over speed not allowed.
 Rotor maximum axial play: ± 3mm.



W22Xd Rib-Cooled Series

355A/B - 400L/J - 400G, IMB3T
Optional - Sleeve bearings

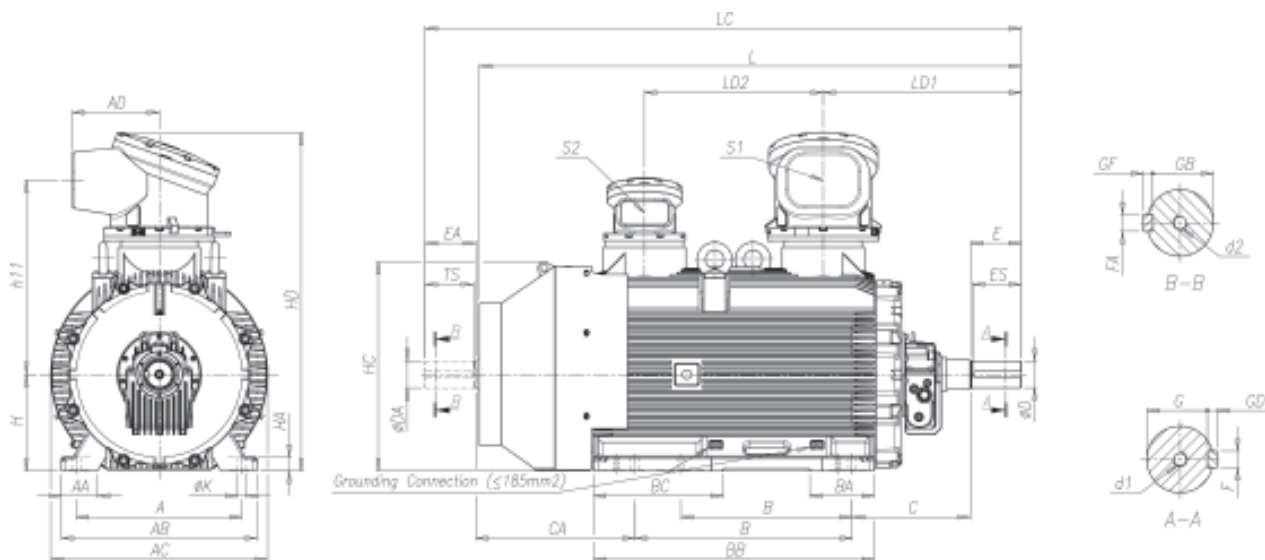

| Frame | Poles | A | AA | AB | AC | AD | BA | BB | BC | B | C | CA | H | HA | HC | HD | h11 | K | L | LC | LD1 | LD2 |
|--------|-------|-----|-----|-----|-----|-----|-----|------|-----|------|------|-----|-----|----|-----|------|-----|----|------|------|-----|-----|
| 355A/B | 2P | 610 | 130 | 730 | 780 | 360 | 225 | 1038 | 523 | 710 | 475 | 731 | 355 | 55 | 765 | 1312 | 758 | 28 | 2131 | 2286 | 735 | 618 |
| | 800 | | | | | | | | | 500 | 2226 | | | | | | | | 2411 | 830 | | |
| 400L/J | 2P | 686 | 150 | 810 | 898 | 360 | 265 | 1160 | 535 | 710 | 485 | 786 | 400 | 58 | 867 | 1402 | 803 | 35 | 2326 | 2481 | 775 | 740 |
| | 900 | | | | | | | | | 515 | 2391 | | | | | | | | 2576 | 845 | | |
| 400G | 4P+ | | | | | | 420 | 1400 | 420 | 1120 | 515 | 801 | | | | | | | 2631 | 2816 | 845 | 980 |

| Frame | Poles | Shaft dimensions | | | | | | | | | | | | | Sleeve Bearings | | Power terminal box - S1 | Auxiliary terminal box - S2 | |
|--------|-------|------------------|-----|-----|------|------|----|------|-----|-----|------|----|----|-------|-----------------|--------------|-------------------------|--|-----------|
| | | D | E | ES | F | G | GD | DA | EA | TS | FA | GB | GF | d1 | d2 | D.E. | N.D.E. | WTBX M | WTBX S |
| 355A/B | 2P | 75m6 | 140 | 125 | 20h9 | 67,5 | 12 | 60m6 | 140 | 125 | 18h9 | 53 | 11 | DSM20 | DSM20 | EFNLB 9-80 | EFNLQ 9-80 | I ≤ 315A : 1xM63x1,5 315A < I ≤ 630A : 3xM63x1,5 | 3xM20x1,5 |
| | 4P+ | 100m6 | 210 | 200 | 28h9 | 90 | 16 | 80m6 | 170 | 160 | 22h9 | 71 | 14 | DSM24 | | EFNLB 11-110 | EFNLQ 11-110 | | |
| 400L/J | 2P | 80m6 | 170 | 160 | 22h9 | 71 | 14 | 60m6 | 140 | 125 | 18h9 | 53 | 11 | DSM20 | | EFNLB 9-80 | EFNLQ 9-80 | | |
| | 4P+ | 110m6 | 210 | 200 | 28h9 | 100 | 16 | 80m6 | 170 | 160 | 22h9 | 71 | 14 | DSM24 | | EFNLB 11-110 | EFNLQ 11-110 | | |
| 400G | 4P+ | 110m6 | 210 | 200 | 28h9 | 100 | 16 | 80m6 | 170 | 160 | 22h9 | 71 | 14 | DSM24 | EFNLB 11-110 | EFNLQ 11-110 | | | |

Notes:
 All the dimensions are in millimeters.
 Please, do not use these dimensions for construction. Certified drawings under request.
 External thrust shall be informed at the time of Inquiry/Order.
 Execution with second shaft end is optional and available under request.
 For other special executions please refer to us.
 The dimensions shown are subject to change without prior notice.
 Rotor is not self-aligned, customer must ensure alignment.
 Over speed not allowed.
 Rotor maximum axial play: ± 3mm.

W22Xd Rib-Cooled Series

450K/H - 500K/H - 560H/G, IMB3T
Optional - Sleeve bearings

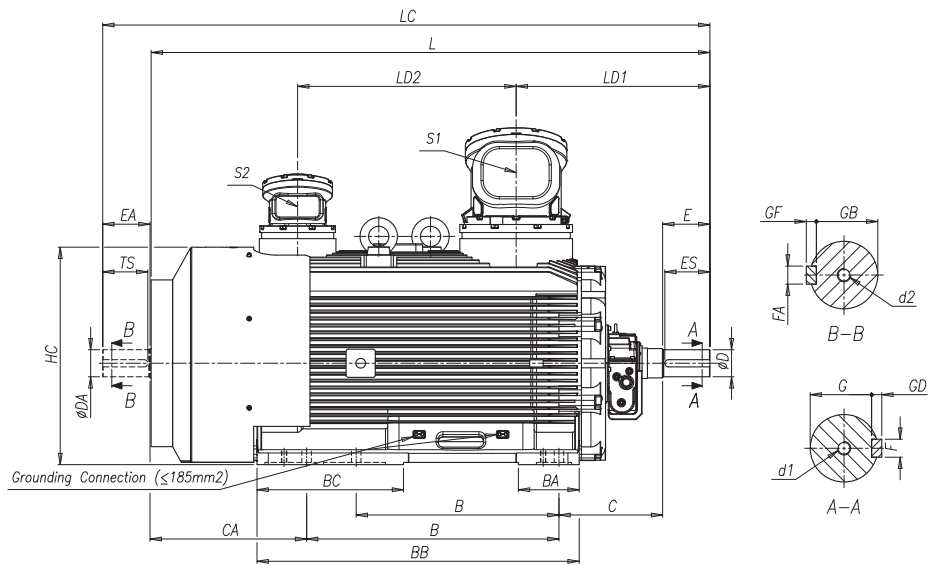
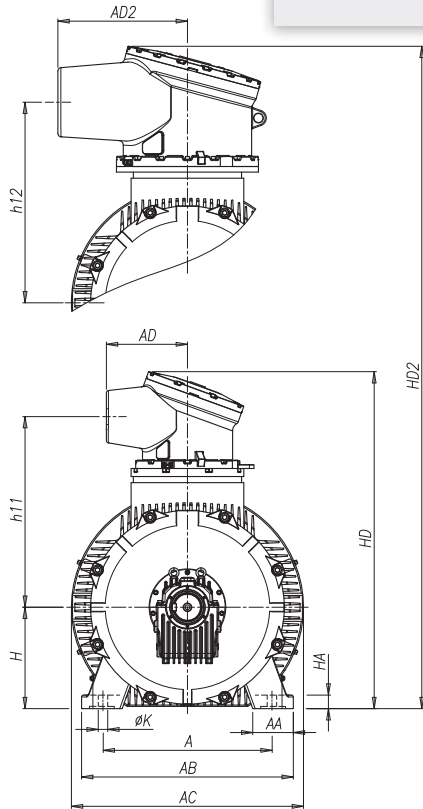
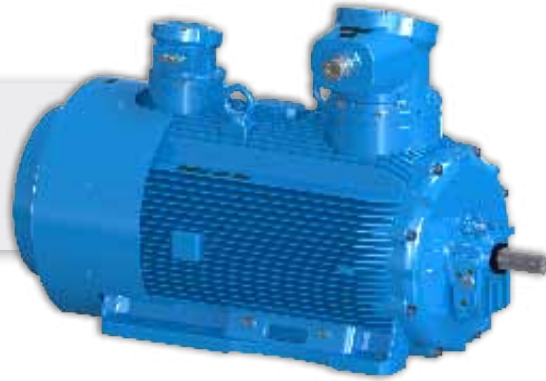

| Frame | Poles | A | AA | AB | AC | AD ⁽¹⁾ | BA | BB | BC | B | C | CA | H | HA | HC | HD ⁽¹⁾ | h11 ⁽¹⁾ | K | L | LC | LD1 | LD2 |
|--------|-------|------|-----|------|------|-------------------|-----|------|-----|------|-----|------|-----|----|------|-------------------|--------------------|----|------|------|-----|------|
| 450K/H | 2P | 750 | 180 | 940 | 1030 | 360 | 270 | 1430 | 650 | 900 | 460 | 832 | 450 | 60 | 965 | 1495 | 890 | 42 | 2567 | 2722 | 820 | 970 |
| | 4P+ | | | | | | | | | 1120 | 485 | | | | | | | | 2632 | 2857 | 885 | |
| 500K/H | 2P | 850 | 200 | 1020 | 1162 | 360 | 375 | 1800 | 915 | 1000 | 475 | 1187 | 500 | 65 | 1081 | 1565 | 866 | 42 | 3067 | 3222 | 845 | 1300 |
| | 4P+ | | | | | | | | | 1250 | 500 | | | | | | | | 3172 | 3397 | 950 | |
| 560H/G | 2P | 1000 | 220 | 1150 | 1324 | 360 | 375 | 1800 | 600 | 1400 | 490 | 840 | 560 | 70 | 1225 | 1710 | 995 | 42 | 3085 | 3240 | 860 | 1300 |
| | 4P+ | | | | | | | | | 1600 | 520 | | | | | | | | 3197 | 3422 | 970 | |

| Frame | Poles | Shaft dimensions | | | | | | | | | | | | | Sleeve Bearings | | Power terminal box - S1 ⁽¹⁾ | Auxiliary terminal box - S2 | |
|--------|-------|------------------|-----|-----|------|-----|----|-------|-----|-----|------|------|----|-------|-----------------|--------------|--|--|-----------|
| | | D | E | ES | F | G | GD | DA | EA | TS | FA | GB | GF | d1 | d2 | D.E. | N.D.E. | WTBX M | WTBX S |
| 450K/H | 2P | 85m6 | 170 | 160 | 22h9 | 76 | 14 | 75m6 | 140 | 125 | 20h9 | 67,5 | 12 | DSM20 | DSM20 | EFNLB 9-80 | EFNLQ 9-80 | I ≤ 315A : 1xM63x1,5 315A < I ≤ 630A : 3xM63x1,5 | 3xM20x1,5 |
| | 4P+ | 120m6 | 210 | 200 | 32h9 | 109 | 18 | 100m6 | 210 | 200 | 28h9 | 90 | 16 | DSM24 | DSM24 | EFNLB 11-125 | EFNLQ 11-125 | | |
| 500K/H | 2P | 90m6 | 170 | 160 | 25h9 | 81 | 14 | 75m6 | 140 | 125 | 20h9 | 67,5 | 12 | DSM24 | DSM24 | EFNLB 9-80 | EFNLQ 9-80 | | |
| | 4P+ | 130m6 | 250 | 240 | 32h9 | 119 | 19 | 110m6 | 210 | 200 | 28h9 | 100 | 16 | | | EFNLB 11-125 | EFNLQ 11-125 | | |
| 560H/G | 2P | 90m6 | 170 | 160 | 25h9 | 81 | 14 | 75m6 | 140 | 125 | 20h9 | 67,5 | 12 | DSM24 | DSM24 | EFNLB 9-80 | EFNLQ 9-80 | | |
| | 4P+ | 130m6 | 250 | 240 | 32h9 | 119 | 19 | 110m6 | 210 | 200 | 28h9 | 100 | 16 | | | EFNLB 11-125 | EFNLQ 11-125 | | |

| Frame | Poles | I > 630A | | | Power terminal box - WTBX-L - S1 |
|--------|-------|----------|------|-----|----------------------------------|
| | | AD2 | HD2 | h12 | |
| 450K/H | 2P | 575 | 1588 | 890 | 630A < I ≤ 1260A : 6xM63x1,5 |
| | 4P+ | | | | |
| 500K/H | 2P | 575 | 1658 | 910 | |
| | 4P+ | | | | |
| 560H/G | 2P | 575 | 1803 | 995 | |
| | 4P+ | | | | |

Notes:

- (1) I ≤ 630A
- All the dimensions are in millimeters.
- Please, do not use these dimensions for construction. Certified drawings under request.
- External thrust shall be informed at the time of Inquiry/Order.
- Execution with second shaft end is optional and available under request.
- For other special executions please refer to us.
- The dimensions shown are subject to change without prior notice.
- Rotor is not self-aligned, customer must ensure alignment.
- Over speed not allowed.
- Rotor maximum axial play: ± 3mm.

6.1.9. High Voltage - Mechanical Data (6600V < U ≤ 11000V) - Anti-friction bearings

W22Xd Rib-Cooled Series

450K/H - 500K/H - 560H/G, IMB3T
Standard - Anti-friction bearings

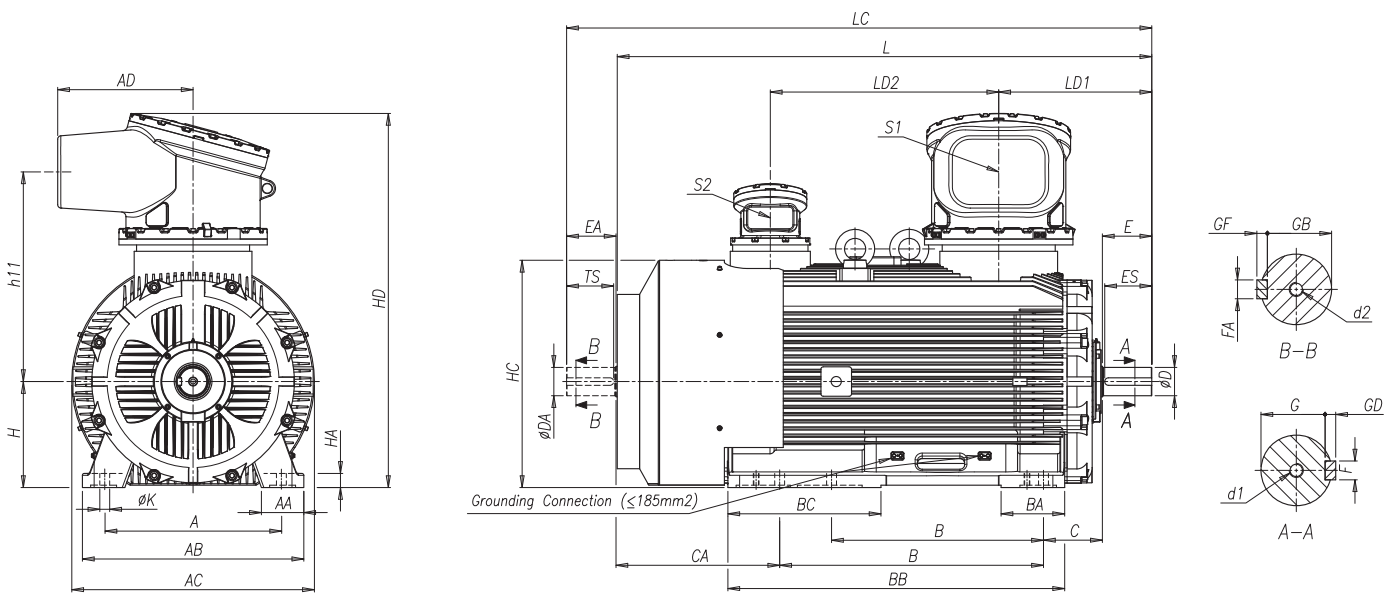

| Frame | Poles | A | AA | AB | AC | AD | BA | BB | BC | B | C | CA | H | HA | HC | HD | h11 | K | L | LC | LD1 | LD2 |
|--------|-------|------|-----|------|------|-----|-----|------|------|--------------|------|-----|-----|------|------|------|-----|----|------|------|-----|------|
| 450K/H | 2P | 750 | 180 | 940 | 1030 | 575 | 270 | 1430 | 650 | 900 | 250 | 705 | 450 | 60 | 965 | 1588 | 890 | 42 | 2230 | 2385 | 610 | 970 |
| | 4P+ | | | | | | | | | 1120 | | | | | | | | | 2270 | 2495 | 650 | |
| 500K/H | 2P | 850 | 200 | 1020 | 1162 | 575 | 375 | 1800 | 915 | 280 | 1065 | 500 | 65 | 1081 | 1658 | 910 | 42 | 42 | 2750 | 2905 | 650 | 1300 |
| | 4P+ | | | | | | | | 1250 | | | | | | | | | | 2830 | 3055 | 730 | |
| 560H/G | 4P+ | 1000 | 220 | 1150 | 1324 | 575 | 375 | 1800 | 600 | 1400 1600 | 280 | 715 | 560 | 70 | 1225 | 1803 | 995 | 42 | 2830 | 3055 | 730 | 1300 |

6

| Frame | Poles | Shaft dimensions | | | | | | | | | | | | | Bearings | | Power terminal box - S1 | Auxiliary terminal box - S2 | |
|--------|-------|------------------|-----|-----|------|-----|----|-------|-----|-----|------|------|----|-------|----------|------------------|-------------------------|--|-----------|
| | | D | E | ES | F | G | GD | DA | EA | TS | FA | GB | GF | d1 | d2 | D.E. | N.D.E. | WTBX L | WTBX S |
| 450K/H | 2P | 85m6 | 170 | 160 | 22h9 | 76 | 14 | 75m6 | 140 | 125 | 20h9 | 67,5 | 12 | DSM20 | DSM20 | 6318C3 | NU218C3 | I ≤ 200A : 1xM63x1,5 200A < I ≤ 400A : 3xM50x1,5 | 3xM20x1,5 |
| | 4P+ | 120m6 | 210 | 200 | 32h9 | 109 | 18 | 100m6 | 210 | 200 | 28h9 | 90 | 16 | DSM24 | DSM24 | 6326C3 | 6326C3 | | |
| 500K/H | 2P | 90m6 | 170 | 160 | 25h9 | 81 | 14 | 75m6 | 140 | 125 | 20h9 | 67,5 | 12 | DSM20 | DSM20 | NU220C3 + 6020C3 | NU220C3 | | |
| | 4P+ | 130m6 | 250 | 240 | 32h9 | 119 | 18 | 110m6 | 210 | 200 | 28h9 | 100 | 16 | | DSM24 | DSM24 | 6328C3 | | |
| 560H/G | 4P+ | 130m6 | 250 | 240 | 32h9 | 119 | 18 | 110m6 | 210 | 200 | 28h9 | 100 | 16 | DSM24 | DSM24 | NU328C3 + 6328C3 | NU328C3 | | |

Notes:

All the dimensions are in millimeters.
Please, do not use these dimensions for construction. Certified drawings under request.
External thrust shall be informed at the time of Inquiry/Order.
Execution with second shaft end is optional and available under request.
For other special executions please refer to us.
The dimensions shown are subject to change without prior notice.

W22Xd Rib-Cooled Series

450K/H - 500K/H - 560H/G, IMV1
Standard - Anti-friction bearings

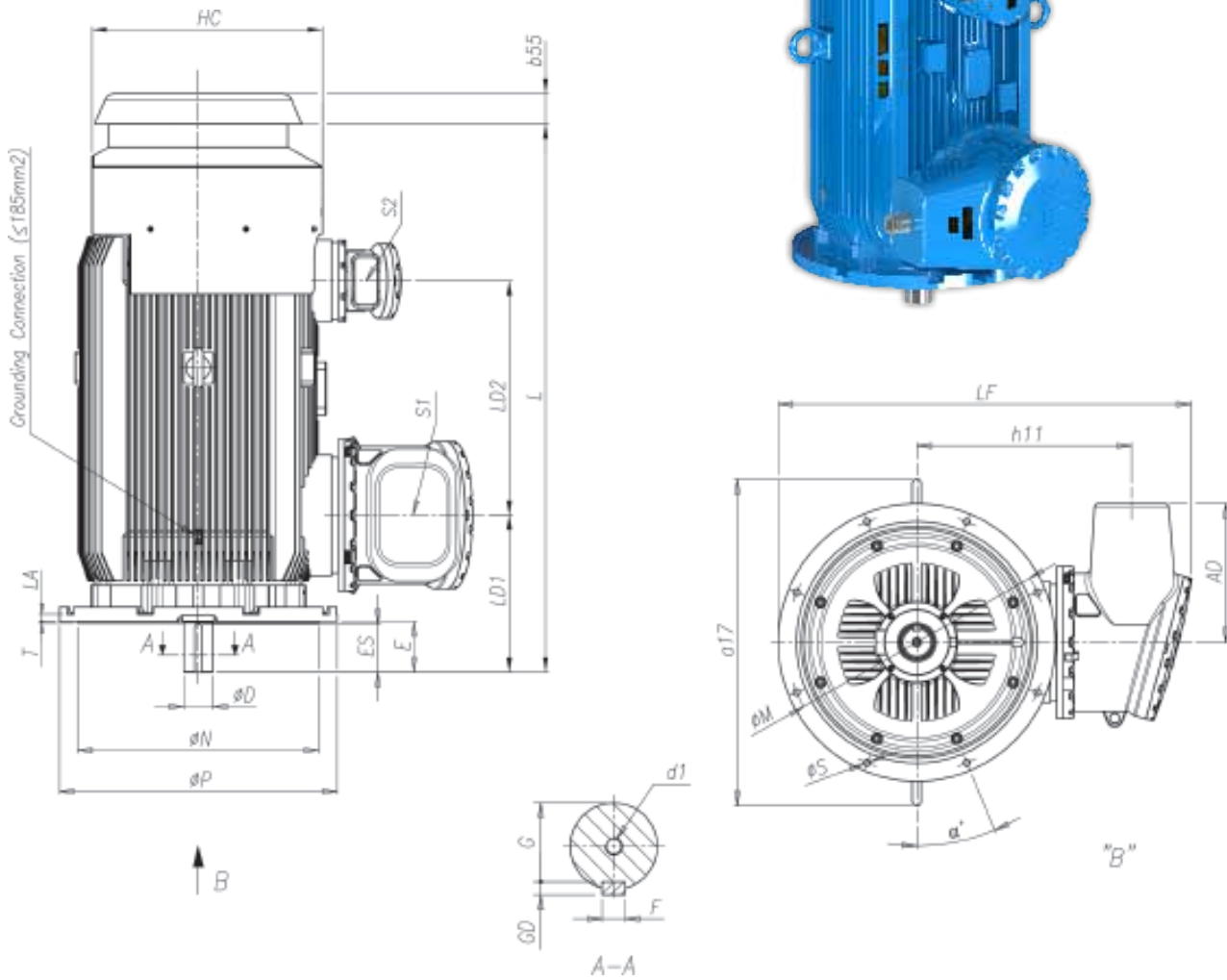

| Frame | Poles | AD | HC | h11 | L | LA | LD1 | LD2 | LF | b55 | a17 | M | N | P | T | S | Nr. Holes | α |
|--------|-------|-----|------|-----|------|----|-----|------|------|------|------|------|------|------|------|----|-----------|-------|
| 450K/H | 4P+ | 575 | 955 | 890 | 2270 | 30 | 650 | 970 | 1713 | 125 | 1352 | 1080 | 1000 | 1150 | 6 | 28 | 8 | 22,5° |
| 500K/H | 4P+ | | 1162 | 910 | | | 715 | 1300 | 1733 | 130 | 1482 | | | | 7 | | | |
| 560H/G | 4P+ | | 1225 | 995 | | | 730 | 1868 | 1630 | 1180 | 1120 | | | | 1250 | | | |

| Frame | Poles | Shaft dimensions | | | | | | | Bearings | | Power terminal box - S1 | Auxiliary terminal box - S2 |
|--------|-------|------------------|-----|-----|------|-----|----|-------|----------|--------|--|-----------------------------|
| | | D | E | ES | F | G | GD | d1 | D.E. | N.D.E. | WTBX L | WTBX S |
| 450K/H | 4P+ | 120m6 | 210 | 200 | 32h9 | 109 | 18 | DSM24 | 6326C3 | 7326 | I ≤ 200A : 1xM63x1,5 200A < I ≤ 400A : 3xM50x1,5 | 3xM20x1,5 |
| 500K/H | 4P+ | 130m6 | 250 | 240 | | 119 | | | 6328C3 | 7328 | | |
| 560H/G | 4P+ | | | | | | | | | | | |

Notes:

All the dimensions are in millimeters.
Please, do not use these dimensions for construction. Certified drawings under request.
External thrust shall be informed at the time of Inquiry/Order.
Execution with second shaft end is optional and available under request.
For other special executions please refer to us.
The dimensions shown are subject to change without prior notice.

6.1.10. High Voltage - Mechanical Data (6600V < U ≤ 11000V) - Sleeve Bearings



W22Xd Rib-Cooled Series

450K/H - 500K/H - 560H/G, IMB3T
Optional - Sleeve bearings

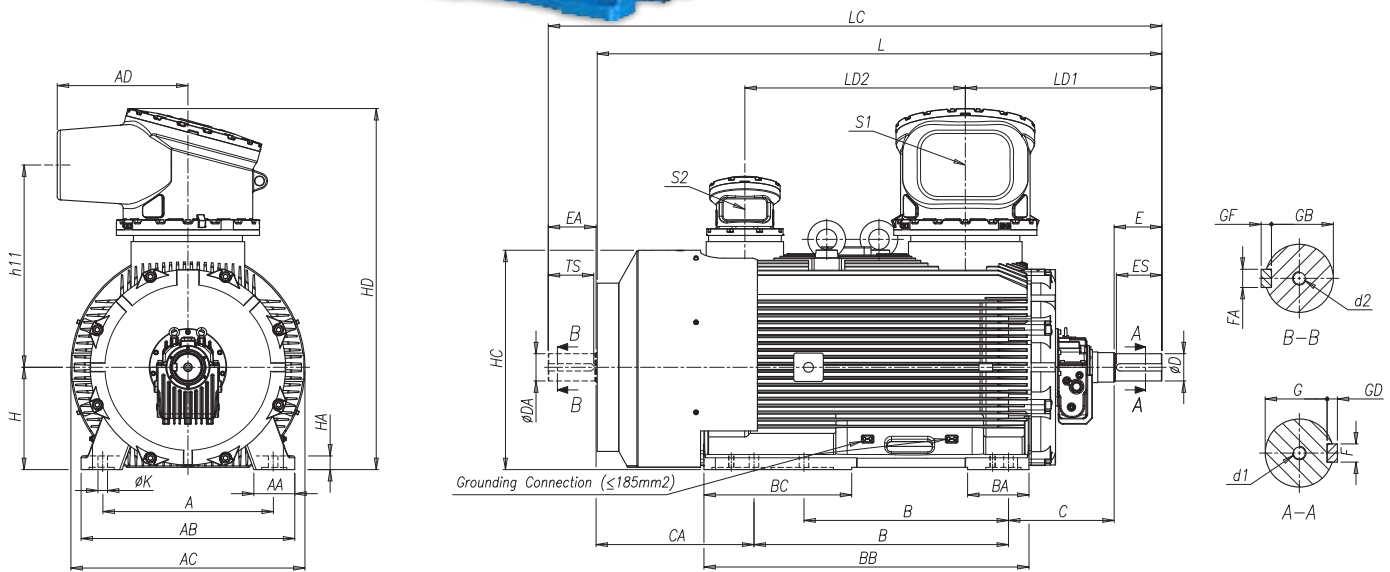

| Frame | Poles | A | AA | AB | AC | AD | BA | BB | BC | B | C | CA | H | HA | HC | HD | h11 | K | L | LC | LD1 | LD2 |
|--------|-------|------|-----|------|------|-----|-----|------|-----|------|-----|------|-----|----|------|------|-----|----|------|------|-----|------|
| 450K/H | 2P | 750 | 180 | 940 | 1030 | 575 | 270 | 1430 | 650 | 900 | 460 | 832 | 450 | 60 | 965 | 1588 | 890 | 42 | 2567 | 2722 | 820 | 970 |
| | 4P+ | | | | | | | | | 1120 | 485 | | | | | | | | 2632 | 2857 | | |
| 500K/H | 2P | 850 | 200 | 1020 | 1162 | 575 | 375 | 1800 | 915 | 1000 | 475 | 1187 | 500 | 65 | 1081 | 1658 | 910 | 42 | 3067 | 3222 | 845 | 1300 |
| | 4P+ | | | | | | | | | 1250 | 500 | | | | | | | | 3172 | 3397 | | |
| 560H/G | 2P | 1000 | 220 | 1150 | 1324 | 575 | 375 | 1800 | 600 | 1400 | 490 | 840 | 560 | 70 | 1225 | 1803 | 995 | 42 | 3085 | 3240 | 860 | 1300 |
| | 4P+ | | | | | | | | | 1600 | 520 | | | | | | | | 3197 | 3422 | | |

| Frame | Poles | Shaft dimensions | | | | | | | | | | | | Bearings | | Power terminal box - S1 | Auxiliary terminal box - S2 | | |
|--------|-------|------------------|-----|-----|------|-----|----|-------|-----|-----|------|------|----|----------|-------|-------------------------|-----------------------------|---|-----------|
| | | D | E | ES | F | G | GD | DA | EA | TS | FA | GB | GF | d1 | d2 | D.E. | N.D.E. | WTBX L | WTBX S |
| 450K/H | 2P | 85m6 | 170 | 160 | 22h9 | 76 | 14 | 75m6 | 140 | 125 | 20h9 | 67,5 | 12 | DSM20 | DSM20 | EFNLB 9-80 | EFNLQ 9-80 | I ≤ 200A : 1xM63x1,5 200A < I ≤ 400A : 3xM50x1,5 | 3xM20x1,5 |
| | 4P+ | 120m6 | 210 | 200 | 32h9 | 109 | 18 | 100m6 | 210 | 200 | 28h9 | 90 | 16 | DSM24 | DSM24 | EFNLB 11-125 | EFNLQ 11-125 | | |
| 500K/H | 2P | 90m6 | 170 | 160 | 25h9 | 81 | 14 | 75m6 | 140 | 125 | 20h9 | 67,5 | 12 | DSM24 | DSM24 | EFNLB 9-80 | EFNLQ 9-80 | | |
| | 4P+ | 130m6 | 250 | 240 | 32h9 | 119 | 19 | 110m6 | 210 | 200 | 28h9 | 100 | 16 | | | EFNLB 11-125 | EFNLQ 11-125 | | |
| 560H/G | 2p | 90m6 | 170 | 160 | 25h9 | 81 | 14 | 75m6 | 140 | 125 | 20h9 | 67,5 | 12 | DSM24 | DSM24 | EFNLB 9-80 | EFNLQ 9-80 | | |
| | 4P+ | 130m6 | 250 | 240 | 32h9 | 119 | 19 | 110m6 | 210 | 200 | 28h9 | 100 | 16 | | | EFNLB 11-125 | EFNLQ 11-125 | | |

Notes:
 All the dimensions are in millimeters.
 Please, do not use these dimensions for construction. Certified drawings under request.
 External thrust shall be informed at the time of Inquiry/Order.
 Execution with second shaft end is optional and available under request.
 For other special executions please refer to us.
 The dimensions shown are subject to change without prior notice.
 Rotor is not self-aligned, customer must ensure alignment.
 Over speed not allowed.
 Rotor maximum axial play: ± 3mm.

6.1. W22Xd Tube-Cooled Series

- Ex d(e) IIB T4 Gb (Ex tb IIIC T125°C Db IP6X)
- Ex d(e) IIC T4 Gb (Ex tb IIIC T125°C Db IP6X)
- Ex d(e) I Mb

W22Xd tube-cooled motor line is available for Medium and High Voltage with shaft height from 560mm up to 710mm with the following powers:

| W22Xd - Medium Voltage (1100V < U ≤ 6600V) | | W22Xd - High Voltage (6600V < U ≤ 11000V) | |
|---|-------------|--|-------------|
| Powers (kW) | Speed (RPM) | Powers (kW) | Speed (RPM) |
| 1120 up to 2500 | 3000 | 710 up to 1800 | 3000 |
| 1400 up to 4500 | 1500 | 900 up to 3550 | 1500 |
| 1120 up to 3150 | 1000 | 630 up to 2500 | 1000 |
| 900 up to 2500 | 750 | 500 up to 2000 | 750 |

In relation to the different available optional features, W22Xd rib-cooled motors are designated as follows:

- W22XdBT: Standard Ex d IIB T4 Gb motor
- W22XdBET: Ex d e IIB T4 Gb motor
- W22XdBDT: Ex d IIB T4 Gb and Ex tb IIIC Db IP6X motor
- W22XdBEDT: Ex d e IIB T4 Gb and Ex tb IIIC Db IP6X motor
- W22XdBTS: Ex d IIB T4 Gb motor with sleeve bearings
- W22XdBETS: Ex d e IIB T4 Gb motor with sleeve bearings
- W22XdBDTS: Ex d IIB T4 Gb and Ex tb IIIC Db IP6X motor with sleeve bearings
- W22XdBEDTS: Ex d e IIB T4 Gb and Ex tb IIIC Db IP6X motor with sleeve bearings
- W22XdCT: Standard Ex d IIC T4 Gb motor
- W22XdCET: Ex d e IIC T4 Gb motor
- W22XdCDT: Ex d IIC T4 Gb and Ex tb IIIC Db IP6X motor
- W22XdCEDT: Ex d e IIB T4 Gb and Ex tb IIIC Db IP6X motor
- W22XdMT: Standard Ex d I Mb motor
- W22XdMET: Ex d e I Mb motor
- W22XdMTS: Ex d I Mb motor with sleeve bearings
- W22XdMETS: Ex d e I Mb motor with sleeve bearings



6.2.1. Medium Voltage - Electrical Data (1100V < U ≤ 6600V)

W22Xd Tube-Cooled Series / Standard - Anti-friction bearings and Sleeve Bearings arrangement

| Output | | Frame IEC | T _n (Nm) | I _s / I _n | T _s / T _n | T _{max} / T _n | Inertia J (Kgm²) | Allowable locked rotor time Hot/ Cold (s) | Weight (Kg) | Sound Pressure dB(A) | RPM | Y 3000V/50Hz | | | | | | |
|--------|----|-----------|---------------------|---------------------------------|---------------------------------|-----------------------------------|------------------|---|-------------|----------------------|-----|----------------|--|--|--------------------|--|--|--------------------|
| kW | HP | | | | | | | | | | | % of full load | | | | | | I _n (A) |
| | | | | | | | | | | | | Efficiency η | | | Power Factor Cos φ | | | |
| | | | 50 | 75 | 100 | 50 | 75 | 100 | | | | | | | | | | |

II Pole - 3000 min⁻¹

| | | | | | | | | | | | | | | | | | | | |
|------|------|---------------|------|-----|-----|-----|------|----|----|-------|----|------|------|------|------|------|------|------|-----|
| 1120 | 1515 | W22Xd 560 J/H | 3581 | 6,0 | 0,5 | 2,4 | 18,7 | 15 | 40 | 9100 | 85 | 2987 | 94,1 | 95,3 | 96,0 | 0,81 | 0,87 | 0,88 | 345 |
| 1250 | 1690 | W22Xd 560 J/H | 3996 | 6,0 | 0,5 | 2,4 | 18,9 | 13 | 33 | 9300 | 85 | 2987 | 94,2 | 95,3 | 96,1 | 0,81 | 0,87 | 0,88 | 385 |
| 1400 | 1890 | W22Xd 560 H/G | 4476 | 6,2 | 0,5 | 2,5 | 20,3 | 11 | 30 | 9500 | 85 | 2987 | 94,6 | 95,8 | 96,3 | 0,81 | 0,87 | 0,88 | 429 |
| 1600 | 2160 | W22Xd 560 H/G | 5116 | 6,2 | 0,5 | 2,5 | 23,2 | 11 | 29 | 10250 | 85 | 2987 | 94,8 | 95,8 | 96,4 | 0,82 | 0,88 | 0,89 | 485 |
| 1800 | 2430 | W22Xd 630 K/J | 5751 | 5,9 | 0,5 | 2,3 | 27,9 | 10 | 28 | 11000 | 85 | 2989 | 93,9 | 95,4 | 96,0 | 0,84 | 0,88 | 0,89 | 547 |
| 2000 | 2705 | W22Xd 630 J/H | 6388 | 5,9 | 0,5 | 2,4 | 31,9 | 11 | 34 | 11250 | 85 | 2990 | 94,4 | 95,8 | 96,3 | 0,84 | 0,88 | 0,89 | 607 |
| 2250 | 3040 | W22Xd 630 J/H | 7184 | 6,0 | 0,5 | 2,4 | 33,8 | 10 | 30 | 12000 | 85 | 2991 | 94,7 | 95,9 | 96,5 | 0,84 | 0,88 | 0,89 | 681 |
| 2500 | 3380 | W22Xd 710 K/J | 7988 | 6,2 | 0,5 | 2,5 | 47,3 | 7 | 21 | 13500 | 87 | 2989 | 93,9 | 95,2 | 95,9 | 0,80 | 0,87 | 0,90 | 754 |

IV Pole - 1500 min⁻¹

| | | | | | | | | | | | | | | | | | | | |
|------|------|-------------------|-------|-----|-----|-----|------|----|----|-------|----|------|------|------|------|------|------|------|------|
| 1400 | 1890 | W22Xd 560 J/H | 8967 | 6,0 | 0,5 | 2,1 | 39,8 | 14 | 40 | 10500 | 84 | 1491 | 95,7 | 96,4 | 96,5 | 0,81 | 0,87 | 0,88 | 428 |
| 1600 | 2160 | W22Xd 560 H/G | 10248 | 6,0 | 0,5 | 2,1 | 42,1 | 12 | 34 | 11750 | 84 | 1491 | 95,8 | 96,5 | 96,6 | 0,81 | 0,87 | 0,88 | 489 |
| 1800 | 2430 | W22Xd 630 K/J | 11506 | 5,8 | 0,6 | 2,0 | 90,3 | 12 | 38 | 12000 | 85 | 1494 | 94,9 | 96,0 | 96,5 | 0,84 | 0,88 | 0,88 | 551 |
| 2000 | 2705 | W22Xd 630 K/J | 12776 | 5,8 | 0,6 | 2,0 | 95,5 | 11 | 34 | 12300 | 85 | 1495 | 94,9 | 96,0 | 96,5 | 0,84 | 0,88 | 0,88 | 613 |
| 2250 | 3040 | W22Xd 630 J/H | 14373 | 5,8 | 0,6 | 2,0 | 101 | 10 | 30 | 13500 | 85 | 1495 | 94,9 | 96,0 | 96,5 | 0,84 | 0,88 | 0,88 | 689 |
| 2500 | 3380 | W22Xd 710 J/H | 15970 | 6,0 | 0,4 | 2,1 | 108 | 16 | 40 | 13800 | 86 | 1495 | 94,9 | 96,4 | 96,7 | 0,80 | 0,86 | 0,87 | 773 |
| 2800 | 3785 | W22Xd 710 J/H | 17886 | 6,0 | 0,4 | 2,2 | 114 | 15 | 35 | 14100 | 86 | 1495 | 95,0 | 96,5 | 96,8 | 0,80 | 0,85 | 0,87 | 865 |
| 3150 | 4255 | W22Xd 710 J/H | 20122 | 6,0 | 0,4 | 2,2 | 126 | 15 | 35 | 14500 | 86 | 1495 | 95,0 | 96,5 | 96,8 | 0,81 | 0,86 | 0,87 | 972 |
| 3550 | 4795 | W22Xd 710 J/H | 22677 | 6,0 | 0,4 | 2,2 | 139 | 14 | 33 | 15000 | 86 | 1495 | 95,1 | 96,6 | 96,9 | 0,82 | 0,87 | 0,88 | 1082 |
| 4000 | 5405 | W22Xd 710 H/G | 25535 | 6,0 | 0,4 | 2,3 | 158 | 14 | 33 | 15750 | 86 | 1496 | 95,2 | 96,7 | 97,0 | 0,81 | 0,86 | 0,88 | 1219 |
| 4500 | 6080 | W22Xd 710 H/G (1) | 28727 | 6,0 | 0,5 | 2,3 | 176 | 10 | 22 | 16000 | 86 | 1496 | 95,4 | 96,9 | 97,2 | 0,82 | 0,87 | 0,88 | 1244 |

VI Pole - 1000 min⁻¹

| | | | | | | | | | | | | | | | | | | | |
|------|------|---------------|-------|-----|-----|-----|------|----|----|-------|----|-----|------|------|------|------|------|------|-----|
| 1120 | 1515 | W22Xd 560 J/H | 10750 | 5,8 | 0,7 | 2,3 | 79,2 | 16 | 40 | 10750 | 82 | 995 | 95,1 | 95,9 | 96,2 | 0,78 | 0,84 | 0,86 | 352 |
| 1250 | 1690 | W22Xd 560 H/G | 11997 | 6,0 | 0,8 | 2,5 | 87,4 | 12 | 31 | 11850 | 82 | 995 | 95,1 | 95,9 | 96,2 | 0,78 | 0,84 | 0,86 | 393 |
| 1400 | 1890 | W22Xd 630 K/J | 13437 | 5,5 | 0,5 | 2,0 | 103 | 21 | 40 | 12500 | 83 | 995 | 95,2 | 96,0 | 96,3 | 0,80 | 0,84 | 0,86 | 439 |
| 1600 | 2160 | W22Xd 630 J/H | 15357 | 5,5 | 0,5 | 2,1 | 109 | 18 | 34 | 13650 | 83 | 995 | 95,2 | 96,0 | 96,3 | 0,81 | 0,85 | 0,86 | 502 |
| 1800 | 2430 | W22Xd 710 J/H | 17259 | 5,7 | 0,5 | 2,1 | 191 | 19 | 40 | 13900 | 85 | 996 | 95,3 | 96,1 | 96,4 | 0,82 | 0,86 | 0,87 | 558 |
| 2000 | 2705 | W22Xd 710 J/H | 19177 | 5,7 | 0,5 | 2,1 | 200 | 19 | 40 | 14300 | 85 | 996 | 95,3 | 96,1 | 96,4 | 0,82 | 0,86 | 0,87 | 621 |
| 2250 | 3040 | W22Xd 710 J/H | 21574 | 6,0 | 0,5 | 2,2 | 210 | 16 | 35 | 14750 | 85 | 996 | 95,4 | 96,2 | 96,6 | 0,82 | 0,86 | 0,87 | 696 |
| 2500 | 3380 | W22Xd 710 J/H | 23971 | 6,0 | 0,5 | 2,2 | 230 | 16 | 34 | 15150 | 85 | 996 | 95,4 | 96,2 | 96,6 | 0,82 | 0,86 | 0,87 | 774 |
| 2800 | 3785 | W22Xd 710 H/G | 26874 | 6,0 | 0,5 | 2,1 | 260 | 16 | 34 | 15900 | 85 | 995 | 95,5 | 96,3 | 96,7 | 0,83 | 0,87 | 0,88 | 856 |
| 3150 | 4255 | W22Xd 710 H/G | 30234 | 6,0 | 0,5 | 2,1 | 280 | 15 | 31 | 16200 | 85 | 995 | 95,5 | 96,3 | 96,7 | 0,83 | 0,87 | 0,88 | 962 |

VIII Pole - 750 min⁻¹

| | | | | | | | | | | | | | | | | | | | |
|------|------|---------------|-------|-----|-----|-----|------|----|----|-------|----|-----|------|------|------|------|------|------|-----|
| 900 | 1215 | W22Xd 560 J/H | 11537 | 5,0 | 0,5 | 2,0 | 79,5 | 17 | 38 | 10800 | 82 | 745 | 94,5 | 95,3 | 95,5 | 0,76 | 0,81 | 0,83 | 295 |
| 1000 | 1350 | W22Xd 560 H/G | 12819 | 5,0 | 0,5 | 2,0 | 87,8 | 16 | 36 | 11900 | 82 | 745 | 94,5 | 95,3 | 95,5 | 0,76 | 0,81 | 0,83 | 328 |
| 1120 | 1515 | W22Xd 630 K/J | 14338 | 5,5 | 0,5 | 2,1 | 123 | 14 | 40 | 12200 | 82 | 746 | 94,6 | 95,4 | 95,7 | 0,76 | 0,81 | 0,83 | 367 |
| 1250 | 1690 | W22Xd 630 K/J | 16002 | 6,0 | 0,6 | 2,2 | 130 | 12 | 35 | 12500 | 82 | 746 | 94,7 | 95,5 | 95,8 | 0,76 | 0,81 | 0,83 | 409 |
| 1400 | 1890 | W22Xd 630 J/H | 17922 | 6,0 | 0,6 | 2,2 | 144 | 10 | 31 | 13700 | 82 | 746 | 94,8 | 95,6 | 95,9 | 0,76 | 0,82 | 0,84 | 452 |
| 1600 | 2160 | W22Xd 710 J/H | 20483 | 6,0 | 0,5 | 2,2 | 222 | 22 | 40 | 14600 | 84 | 746 | 94,9 | 95,7 | 96,0 | 0,76 | 0,82 | 0,84 | 515 |
| 1800 | 2430 | W22Xd 710 J/H | 23012 | 6,0 | 0,5 | 2,2 | 243 | 18 | 40 | 14900 | 84 | 747 | 95,1 | 95,9 | 96,2 | 0,76 | 0,82 | 0,84 | 579 |
| 2000 | 2705 | W22Xd 710 J/H | 25569 | 6,0 | 0,5 | 2,2 | 263 | 17 | 38 | 15200 | 84 | 747 | 95,1 | 95,9 | 96,2 | 0,76 | 0,82 | 0,84 | 644 |
| 2250 | 3040 | W22Xd 710 H/G | 28765 | 6,0 | 0,5 | 2,1 | 295 | 15 | 32 | 16000 | 84 | 747 | 95,3 | 96,0 | 96,3 | 0,76 | 0,82 | 0,84 | 723 |
| 2500 | 3380 | W22Xd 710 H/G | 31961 | 6,0 | 0,5 | 2,1 | 316 | 15 | 32 | 16250 | 84 | 747 | 95,3 | 96,0 | 96,3 | 0,76 | 0,82 | 0,84 | 804 |

(1) Voltage: 3300V

T_n = Full load torque
I_s / I_n = Locked rotor current
T_s / T_n = Locked rotor torque

T_{max} / T_n = Breakdown torque
I_n = Full load current

Notes:

- All motors with copper rotor
- The indicated values for sound pressure levels are @ 1m no load, with 3 dB(A) tolerance.
- 2 pole motors only available with sleeve bearings execution, Ex d(e) IIB, Ex d(e) I and Ex tb IIIC.
- All values are according to IEC 60034-1 Standard tolerances.
- This data can be changed without prior notice.

W22Xd Tube-Cooled Series / Standard - Anti-friction bearings and Sleeve Bearings arrangement

| | | | | | | | | | | | | | Y 4160V/60Hz | | | | | | |
|---|------|---------------|------------------------|---------------------------------|---------------------------------|-----------------------------------|----------------------------------|--|----------------|----------------------------|-----|----------------|--------------|------|--------------------|------|------|--------------------|-----|
| Output | | Frame IEC | T _n (Nm) | I _s / I _n | T _s / T _n | T _{max} / T _n | Inertia J (Kgm ²) | Allowable locked rotor time Hot/ Cold (s) | Weight (Kg) | Sound Pressure dB(A) | RPM | % of full load | | | | | | I _n (A) | |
| kW | HP | | | | | | | | | | | Efficiency η | | | Power Factor Cos φ | | | | |
| | | | | | | | | | | | | 50 | 75 | 100 | 50 | 75 | 100 | | |
| II Pole - 3000 min⁻¹ | | | | | | | | | | | | | | | | | | | |
| 1120 | 1515 | W22Xd 560 J/H | 2982 | 6,0 | 0,5 | 2,8 | 18,7 | 12 | 32 | 9100 | 89 | 3587 | 93,8 | 95,3 | 96,0 | 0,83 | 0,87 | 0,89 | 182 |
| 1250 | 1690 | W22Xd 560 J/H | 3328 | 6,0 | 0,5 | 2,8 | 18,9 | 10 | 27 | 9300 | 89 | 3587 | 94,1 | 95,1 | 96,1 | 0,83 | 0,88 | 0,89 | 203 |
| 1400 | 1890 | W22Xd 560 H/G | 3727 | 6,4 | 0,6 | 2,8 | 20,3 | 9 | 24 | 9500 | 89 | 3587 | 94,4 | 95,7 | 96,3 | 0,84 | 0,89 | 0,90 | 224 |
| 1600 | 2160 | W22Xd 560 H/G | 4260 | 6,4 | 0,6 | 2,8 | 23,2 | 8 | 24 | 10250 | 89 | 3587 | 94,7 | 95,9 | 96,4 | 0,84 | 0,89 | 0,90 | 256 |
| 1800 | 2430 | W22Xd 630 K/J | 4788 | 6,0 | 0,5 | 2,3 | 27,9 | 10 | 32 | 11000 | 89 | 3590 | 91,3 | 93,7 | 94,9 | 0,82 | 0,88 | 0,89 | 296 |
| 2000 | 2705 | W22Xd 630 J/H | 5320 | 6,0 | 0,5 | 2,3 | 31,9 | 10 | 32 | 11250 | 89 | 3590 | 92,0 | 94,0 | 95,1 | 0,85 | 0,89 | 0,90 | 324 |
| 2250 | 3040 | W22Xd 630 J/H | 5985 | 6,0 | 0,5 | 2,3 | 33,8 | 9 | 28 | 12000 | 89 | 3590 | 92,6 | 94,6 | 95,5 | 0,85 | 0,89 | 0,90 | 363 |
| 2500 | 3380 | W22Xd 710 K/J | 6654 | 6,1 | 0,5 | 2,5 | 47,3 | 6 | 15 | 13500 | 91 | 3588 | 93,0 | 94,7 | 95,6 | 0,82 | 0,88 | 0,91 | 399 |
| IV Pole - 1500 min⁻¹ | | | | | | | | | | | | | | | | | | | |
| 1400 | 1890 | W22Xd 560 J/H | 7461 | 6,0 | 0,5 | 2,1 | 39,8 | 16 | 35 | 10500 | 88 | 1792 | 95,3 | 96,2 | 96,6 | 0,84 | 0,88 | 0,89 | 226 |
| 1600 | 2160 | W22Xd 560 H/G | 8527 | 6,0 | 0,5 | 2,1 | 42,1 | 14 | 30 | 11750 | 88 | 1792 | 95,6 | 96,5 | 96,8 | 0,84 | 0,88 | 0,88 | 261 |
| 1800 | 2430 | W22Xd 630 K/J | 9577 | 6,0 | 0,5 | 1,9 | 90,3 | 15 | 36 | 12000 | 89 | 1795 | 93,9 | 95,4 | 96,0 | 0,85 | 0,88 | 0,88 | 296 |
| 2000 | 2705 | W22Xd 630 K/J | 10641 | 6,0 | 0,5 | 1,9 | 95,5 | 14 | 33 | 12300 | 89 | 1795 | 94,3 | 95,7 | 96,3 | 0,85 | 0,88 | 0,88 | 328 |
| 2250 | 3040 | W22Xd 630 J/H | 11971 | 6,0 | 0,5 | 2,0 | 101 | 13 | 30 | 13500 | 89 | 1795 | 94,7 | 96,0 | 96,5 | 0,85 | 0,88 | 0,88 | 368 |
| 2500 | 3380 | W22Xd 710 J/H | 13308 | 6,0 | 0,4 | 1,9 | 108 | 19 | 40 | 13800 | 90 | 1794 | 94,4 | 95,8 | 96,3 | 0,85 | 0,88 | 0,88 | 409 |
| 2800 | 3785 | W22Xd 710 J/H | 14905 | 6,0 | 0,4 | 1,9 | 114 | 17 | 36 | 14100 | 90 | 1794 | 94,4 | 95,8 | 96,3 | 0,85 | 0,88 | 0,88 | 459 |
| 3150 | 4255 | W22Xd 710 J/H | 16768 | 6,0 | 0,4 | 2,0 | 126 | 16 | 35 | 14500 | 90 | 1794 | 94,4 | 95,8 | 96,3 | 0,85 | 0,88 | 0,88 | 516 |
| 3550 | 4795 | W22Xd 710 J/H | 18898 | 6,0 | 0,4 | 2,0 | 139 | 15 | 33 | 15000 | 90 | 1794 | 94,6 | 96,0 | 96,4 | 0,85 | 0,88 | 0,89 | 574 |
| 4000 | 5405 | W22Xd 710 H/G | 21293 | 6,0 | 0,4 | 2,0 | 158 | 15 | 33 | 15750 | 90 | 1794 | 94,7 | 96,2 | 96,5 | 0,86 | 0,89 | 0,89 | 646 |
| 4500 | 6080 | W22Xd 710 H/G | 23955 | 6,0 | 0,4 | 2,0 | 176 | 14 | 32 | 16000 | 90 | 1794 | 94,9 | 96,4 | 96,7 | 0,86 | 0,89 | 0,89 | 726 |
| VI Pole - 1000 min⁻¹ | | | | | | | | | | | | | | | | | | | |
| 1120 | 1515 | W22Xd 560 J/H | 8951 | 5,8 | 0,7 | 2,3 | 79,2 | 18 | 38 | 10750 | 86 | 1195 | 94,9 | 95,9 | 96,3 | 0,82 | 0,87 | 0,88 | 183 |
| 1250 | 1690 | W22Xd 560 H/G | 9990 | 6,0 | 0,8 | 2,5 | 87,4 | 14 | 30 | 11850 | 86 | 1195 | 95,2 | 96,2 | 96,5 | 0,82 | 0,87 | 0,87 | 207 |
| 1400 | 1890 | W22Xd 630 K/J | 11188 | 5,5 | 0,5 | 2,0 | 103 | 17 | 36 | 12500 | 87 | 1195 | 95,2 | 96,0 | 96,3 | 0,80 | 0,84 | 0,86 | 235 |
| 1600 | 2160 | W22Xd 630 J/H | 12787 | 5,5 | 0,5 | 2,1 | 109 | 17 | 36 | 13650 | 87 | 1195 | 95,2 | 96,0 | 96,3 | 0,81 | 0,85 | 0,86 | 268 |
| 1800 | 2430 | W22Xd 710 J/H | 14373 | 5,7 | 0,4 | 2,1 | 191 | 21 | 40 | 13900 | 89 | 1196 | 95,3 | 96,1 | 96,4 | 0,82 | 0,86 | 0,87 | 298 |
| 2000 | 2705 | W22Xd 710 J/H | 15970 | 5,7 | 0,4 | 2,1 | 200 | 21 | 40 | 14300 | 89 | 1196 | 95,3 | 96,1 | 96,4 | 0,82 | 0,86 | 0,87 | 331 |
| 2250 | 3040 | W22Xd 710 J/H | 17966 | 6,0 | 0,4 | 2,2 | 210 | 18 | 35 | 14750 | 89 | 1196 | 95,4 | 96,2 | 96,6 | 0,82 | 0,86 | 0,87 | 372 |
| 2500 | 3380 | W22Xd 710 J/H | 19962 | 6,0 | 0,4 | 2,2 | 230 | 17 | 33 | 15150 | 89 | 1196 | 95,4 | 96,2 | 96,6 | 0,82 | 0,86 | 0,87 | 413 |
| 2800 | 3785 | W22Xd 710 H/G | 22377 | 6,0 | 0,5 | 2,1 | 260 | 15 | 29 | 15900 | 89 | 1195 | 95,5 | 96,3 | 96,7 | 0,83 | 0,87 | 0,88 | 457 |
| 3150 | 4255 | W22Xd 710 H/G | 25174 | 6,0 | 0,5 | 2,1 | 280 | 14 | 26 | 16200 | 89 | 1195 | 95,5 | 96,3 | 96,7 | 0,83 | 0,87 | 0,88 | 514 |
| VIII Pole - 750 min⁻¹ | | | | | | | | | | | | | | | | | | | |
| 900 | 1215 | W22Xd 560 J/H | 9603 | 5,0 | 0,5 | 2,0 | 79,5 | 19 | 37 | 10800 | 86 | 895 | 94,5 | 95,3 | 95,5 | 0,76 | 0,81 | 0,83 | 158 |
| 1000 | 1350 | W22Xd 560 H/G | 10670 | 5,0 | 0,5 | 2,0 | 87,8 | 19 | 37 | 11900 | 86 | 895 | 94,5 | 95,3 | 95,5 | 0,76 | 0,81 | 0,83 | 175 |
| 1120 | 1515 | W22Xd 630 K/J | 11938 | 5,5 | 0,5 | 2,1 | 123 | 15 | 38 | 12200 | 86 | 896 | 94,6 | 95,4 | 95,7 | 0,76 | 0,81 | 0,83 | 196 |
| 1250 | 1690 | W22Xd 630 K/J | 13323 | 6,0 | 0,6 | 2,2 | 130 | 13 | 35 | 12500 | 86 | 896 | 94,7 | 95,5 | 95,8 | 0,76 | 0,81 | 0,83 | 218 |
| 1400 | 1890 | W22Xd 630 J/H | 14922 | 6,0 | 0,6 | 2,2 | 144 | 10 | 25 | 13700 | 86 | 896 | 94,8 | 95,6 | 95,9 | 0,76 | 0,82 | 0,84 | 241 |
| 1600 | 2160 | W22Xd 710 J/H | 17054 | 6,0 | 0,5 | 2,2 | 222 | 19 | 40 | 14600 | 88 | 896 | 94,9 | 95,7 | 96,0 | 0,76 | 0,82 | 0,84 | 275 |
| 1800 | 2430 | W22Xd 710 J/H | 19164 | 6,0 | 0,5 | 2,2 | 243 | 18 | 37 | 14900 | 88 | 897 | 95,1 | 95,9 | 96,2 | 0,76 | 0,82 | 0,84 | 309 |
| 2000 | 2705 | W22Xd 710 J/H | 21293 | 6,0 | 0,5 | 2,2 | 263 | 18 | 35 | 15200 | 88 | 897 | 95,1 | 95,9 | 96,2 | 0,76 | 0,82 | 0,84 | 343 |
| 2250 | 3040 | W22Xd 710 H/G | 23955 | 6,0 | 0,5 | 2,1 | 295 | 18 | 35 | 16000 | 88 | 897 | 95,3 | 96,0 | 96,3 | 0,76 | 0,82 | 0,84 | 386 |
| 2500 | 3380 | W22Xd 710 H/G | 26616 | 6,0 | 0,5 | 2,1 | 316 | 17 | 34 | 16250 | 88 | 897 | 95,3 | 96,0 | 96,3 | 0,76 | 0,82 | 0,84 | 429 |

T_n = Full load torque
I_s / I_n = Locked rotor current

T_{max} / T_n = Breakdown torque
I_n = Full load current

Notes:
- All motors with copper rotor
- The indicated values for sound pressure levels are @ 1m no load, with 3 dB(A) tolerance.
- 2 pole motors only available with sleeve bearings execution, Ex d(e) IIB, Ex d(e) I and Ex tb IIIC.
- All values are according to IEC 60034-1 Standard tolerances.
- This data can be changed without prior notice.

T_s / T_n = Locked rotor torque

W22Xd Tube-Cooled Series / Standard - Anti-friction bearings and Sleeve Bearings arrangement

| Output | | Frame IEC | T _n (Nm) | I _s / I _n | T _s / T _n | T _{max} / T _n | Inertia J (Kgm ²) | Allowable locked rotor time Hot/ Cold (s) | Weight (Kg) | Sound Pressure dB(A) | RPM | Y 6000V/50Hz | | | | | | |
|--------|----|-----------|---------------------|---------------------------------|---------------------------------|-----------------------------------|-------------------------------|---|-------------|----------------------|-----|----------------|--|--|--------------------|--|--|--------------------|
| kW | HP | | | | | | | | | | | % of full load | | | | | | I _n (A) |
| | | | | | | | | | | | | Efficiency η | | | Power Factor Cos φ | | | |
| | | 50 | 75 | 100 | 50 | 75 | 100 | | | | | | | | | | | |

II Pole - 3000 min⁻¹

| | | | | | | | | | | | | | | | | | | | |
|------|------|---------------|------|-----|-----|-----|------|----|----|-------|----|------|------|------|------|------|------|------|-----|
| 1120 | 1515 | W22Xd 560 J/H | 3581 | 6,0 | 0,5 | 2,4 | 18,7 | 15 | 40 | 9100 | 85 | 2987 | 94,1 | 95,3 | 96,0 | 0,81 | 0,87 | 0,88 | 128 |
| 1250 | 1690 | W22Xd 560 J/H | 3996 | 6,0 | 0,5 | 2,4 | 18,9 | 13 | 33 | 9300 | 85 | 2987 | 94,2 | 95,3 | 96,1 | 0,81 | 0,87 | 0,88 | 142 |
| 1400 | 1890 | W22Xd 560 H/G | 4476 | 6,2 | 0,5 | 2,5 | 20,3 | 11 | 30 | 9500 | 85 | 2987 | 94,6 | 95,8 | 96,3 | 0,81 | 0,87 | 0,88 | 159 |
| 1600 | 2160 | W22Xd 560 H/G | 5116 | 6,2 | 0,5 | 2,5 | 23,2 | 11 | 29 | 10250 | 85 | 2987 | 94,8 | 95,8 | 96,4 | 0,82 | 0,88 | 0,89 | 179 |
| 1800 | 2430 | W22Xd 630 K/J | 5751 | 5,9 | 0,5 | 2,3 | 27,9 | 10 | 28 | 11000 | 85 | 2989 | 93,9 | 95,4 | 96,0 | 0,84 | 0,88 | 0,89 | 203 |
| 2000 | 2705 | W22Xd 630 J/H | 6388 | 5,9 | 0,5 | 2,4 | 31,9 | 11 | 34 | 11250 | 85 | 2990 | 94,4 | 95,8 | 96,3 | 0,84 | 0,88 | 0,89 | 225 |
| 2250 | 3040 | W22Xd 630 J/H | 7184 | 6,0 | 0,5 | 2,4 | 33,8 | 10 | 30 | 12000 | 85 | 2991 | 94,7 | 95,9 | 96,5 | 0,84 | 0,88 | 0,89 | 252 |
| 2500 | 3380 | W22Xd 710 K/J | 7988 | 6,2 | 0,5 | 2,5 | 47,3 | 7 | 21 | 13500 | 87 | 2989 | 93,9 | 95,2 | 95,9 | 0,80 | 0,87 | 0,90 | 279 |

IV Pole - 1500 min⁻¹

| | | | | | | | | | | | | | | | | | | | |
|------|------|---------------|-------|-----|-----|-----|------|----|----|-------|----|------|------|------|------|------|------|------|-----|
| 1400 | 1890 | W22Xd 560 J/H | 8967 | 6,0 | 0,5 | 2,1 | 39,8 | 14 | 40 | 10500 | 84 | 1491 | 95,7 | 96,4 | 96,5 | 0,81 | 0,87 | 0,88 | 159 |
| 1600 | 2160 | W22Xd 560 H/G | 10248 | 6,0 | 0,5 | 2,1 | 42,1 | 12 | 34 | 11750 | 84 | 1491 | 95,8 | 96,5 | 96,6 | 0,81 | 0,87 | 0,88 | 181 |
| 1800 | 2430 | W22Xd 630 K/J | 11506 | 5,8 | 0,6 | 2,0 | 90,3 | 12 | 38 | 12000 | 85 | 1494 | 94,9 | 96,0 | 96,5 | 0,84 | 0,88 | 0,88 | 204 |
| 2000 | 2705 | W22Xd 630 K/J | 12776 | 5,8 | 0,6 | 2,0 | 95,5 | 11 | 34 | 12300 | 85 | 1495 | 94,9 | 96,0 | 96,5 | 0,84 | 0,88 | 0,88 | 227 |
| 2250 | 3040 | W22Xd 630 J/H | 14373 | 5,8 | 0,6 | 2,0 | 101 | 10 | 30 | 13500 | 85 | 1495 | 94,9 | 96,0 | 96,5 | 0,84 | 0,88 | 0,88 | 255 |
| 2500 | 3380 | W22Xd 710 J/H | 15970 | 6,0 | 0,4 | 2,1 | 108 | 16 | 40 | 13800 | 86 | 1495 | 94,9 | 96,4 | 96,7 | 0,80 | 0,86 | 0,87 | 286 |
| 2800 | 3785 | W22Xd 710 J/H | 17886 | 6,0 | 0,4 | 2,2 | 114 | 15 | 35 | 14100 | 86 | 1495 | 95,0 | 96,5 | 96,8 | 0,80 | 0,85 | 0,87 | 320 |
| 3150 | 4255 | W22Xd 710 J/H | 20122 | 6,0 | 0,4 | 2,2 | 126 | 15 | 35 | 14500 | 86 | 1495 | 95,0 | 96,5 | 96,8 | 0,81 | 0,86 | 0,87 | 360 |
| 3550 | 4795 | W22Xd 710 J/H | 22677 | 6,0 | 0,4 | 2,2 | 139 | 14 | 33 | 15000 | 86 | 1495 | 95,1 | 96,6 | 96,9 | 0,82 | 0,87 | 0,88 | 401 |
| 4000 | 5405 | W22Xd 710 H/G | 25535 | 6,0 | 0,4 | 2,3 | 158 | 14 | 33 | 15750 | 86 | 1496 | 95,2 | 96,7 | 97,0 | 0,81 | 0,86 | 0,88 | 451 |
| 4500 | 6080 | W22Xd 710 H/G | 28727 | 6,0 | 0,5 | 2,3 | 176 | 10 | 22 | 16000 | 86 | 1496 | 95,4 | 96,9 | 97,2 | 0,82 | 0,87 | 0,88 | 506 |

VI Pole - 1000 min⁻¹

| | | | | | | | | | | | | | | | | | | | |
|------|------|---------------|-------|-----|-----|-----|------|----|----|-------|----|-----|------|------|------|------|------|------|-----|
| 1120 | 1515 | W22Xd 560 J/H | 10750 | 5,8 | 0,7 | 2,3 | 79,2 | 16 | 40 | 10750 | 82 | 995 | 95,1 | 95,9 | 96,2 | 0,78 | 0,84 | 0,86 | 130 |
| 1250 | 1690 | W22Xd 560 H/G | 11997 | 6,0 | 0,8 | 2,5 | 87,4 | 12 | 31 | 11850 | 82 | 995 | 95,1 | 95,9 | 96,2 | 0,78 | 0,84 | 0,86 | 145 |
| 1400 | 1890 | W22Xd 630 K/J | 13437 | 5,5 | 0,5 | 2,0 | 103 | 21 | 40 | 12500 | 83 | 995 | 95,2 | 96,0 | 96,3 | 0,80 | 0,84 | 0,86 | 163 |
| 1600 | 2160 | W22Xd 630 J/H | 15357 | 5,5 | 0,5 | 2,1 | 109 | 18 | 34 | 13650 | 83 | 995 | 95,2 | 96,0 | 96,3 | 0,81 | 0,85 | 0,86 | 186 |
| 1800 | 2430 | W22Xd 710 J/H | 17259 | 5,7 | 0,5 | 2,1 | 191 | 19 | 40 | 13900 | 85 | 996 | 95,3 | 96,1 | 96,4 | 0,82 | 0,86 | 0,87 | 207 |
| 2000 | 2705 | W22Xd 710 J/H | 19177 | 5,7 | 0,5 | 2,1 | 200 | 19 | 40 | 14300 | 85 | 996 | 95,3 | 96,1 | 96,4 | 0,82 | 0,86 | 0,87 | 229 |
| 2250 | 3040 | W22Xd 710 J/H | 21574 | 6,0 | 0,5 | 2,2 | 210 | 16 | 35 | 14750 | 85 | 996 | 95,4 | 96,2 | 96,6 | 0,82 | 0,86 | 0,87 | 258 |
| 2500 | 3380 | W22Xd 710 J/H | 23971 | 6,0 | 0,5 | 2,2 | 230 | 16 | 34 | 15150 | 85 | 996 | 95,4 | 96,2 | 96,6 | 0,82 | 0,86 | 0,87 | 286 |
| 2800 | 3785 | W22Xd 710 H/G | 26874 | 6,0 | 0,5 | 2,1 | 260 | 16 | 34 | 15900 | 85 | 995 | 95,5 | 96,3 | 96,7 | 0,83 | 0,87 | 0,88 | 317 |
| 3150 | 4255 | W22Xd 710 H/G | 30234 | 6,0 | 0,5 | 2,1 | 280 | 15 | 31 | 16200 | 85 | 995 | 95,5 | 96,3 | 96,7 | 0,83 | 0,87 | 0,88 | 356 |

VIII Pole - 750 min⁻¹

| | | | | | | | | | | | | | | | | | | | |
|------|------|---------------|-------|-----|-----|-----|------|----|----|-------|----|-----|------|------|------|------|------|------|-----|
| 900 | 1215 | W22Xd 560 J/H | 11537 | 5,0 | 0,5 | 2,0 | 79,5 | 17 | 38 | 10800 | 82 | 745 | 94,5 | 95,3 | 95,5 | 0,76 | 0,81 | 0,83 | 109 |
| 1000 | 1350 | W22Xd 560 H/G | 12819 | 5,0 | 0,5 | 2,0 | 87,8 | 16 | 36 | 11900 | 82 | 745 | 94,5 | 95,3 | 95,5 | 0,76 | 0,81 | 0,83 | 121 |
| 1120 | 1515 | W22Xd 630 K/J | 14338 | 5,5 | 0,5 | 2,1 | 123 | 14 | 40 | 12200 | 82 | 746 | 94,6 | 95,4 | 95,7 | 0,76 | 0,81 | 0,83 | 136 |
| 1250 | 1690 | W22Xd 630 K/J | 16002 | 6,0 | 0,6 | 2,2 | 130 | 12 | 35 | 12500 | 82 | 746 | 94,7 | 95,5 | 95,8 | 0,76 | 0,81 | 0,83 | 151 |
| 1400 | 1890 | W22Xd 630 J/H | 17922 | 6,0 | 0,6 | 2,2 | 144 | 10 | 31 | 13700 | 82 | 746 | 94,8 | 95,6 | 95,9 | 0,76 | 0,82 | 0,84 | 167 |
| 1600 | 2160 | W22Xd 710 J/H | 20483 | 6,0 | 0,5 | 2,2 | 222 | 22 | 40 | 14600 | 84 | 746 | 94,9 | 95,7 | 96,0 | 0,76 | 0,82 | 0,84 | 191 |
| 1800 | 2430 | W22Xd 710 J/H | 23012 | 6,0 | 0,5 | 2,2 | 243 | 18 | 40 | 14900 | 84 | 747 | 95,1 | 95,9 | 96,2 | 0,76 | 0,82 | 0,84 | 214 |
| 2000 | 2705 | W22Xd 710 J/H | 25569 | 6,0 | 0,5 | 2,2 | 263 | 17 | 38 | 15200 | 84 | 747 | 95,1 | 95,9 | 96,2 | 0,76 | 0,82 | 0,84 | 238 |
| 2250 | 3040 | W22Xd 710 H/G | 28765 | 6,0 | 0,5 | 2,1 | 295 | 15 | 32 | 16000 | 84 | 747 | 95,3 | 96,0 | 96,3 | 0,76 | 0,82 | 0,84 | 268 |
| 2500 | 3380 | W22Xd 710 H/G | 31961 | 6,0 | 0,5 | 2,1 | 316 | 15 | 32 | 16250 | 84 | 747 | 95,3 | 96,0 | 96,3 | 0,76 | 0,82 | 0,84 | 297 |

T_n = Full load torque
 I_s / I_n = Locked rotor current
 T_s / T_n = Locked rotor torque

T_{max} / T_n = Breakdown torque
 I_n = Full load current

Notes:
 - All motors with copper rotor
 -The indicated values for sound pressure levels are @ 1m no load, with 3 dB(A) tolerance.
 -All values are according to IEC 60034-1 Standard tolerances.
 -This data can be changed without prior notice.

6.2.2. High Voltage - Electrical Data (6600V < U ≤ 11000V)

W22Xd Tube-Cooled Series / Standard - Anti-friction bearings and Sleeve Bearings arrangement

| Output | | Frame IEC | T _n (Nm) | I _s /I _n | T _s /T _n | T _{max} /T _n | Inertia J (Kgm ²) | Allowable locked rotor time Hot/ Cold (s) | Weight (Kg) | Sound Pressure dB(A) | RPM | Y 10000V/50Hz | | | | | | I _n (A) | |
|--|------|--------------|------------------------|--------------------------------|--------------------------------|----------------------------------|----------------------------------|--|----------------|----------------------------|-----|----------------|------|------|--------------------|------|------|--------------------|------|
| kW | HP | | | | | | | | | | | % of full load | | | | | | | |
| | | | | | | | | | | | | Efficiency η | | | Power Factor Cos φ | | | | |
| | | | | | | | | | | | | 50 | 75 | 100 | 50 | 75 | 100 | | |
| II Pole - 3000 min⁻¹ | | | | | | | | | | | | | | | | | | | |
| 710 | 960 | W22Xd 560J/H | 2271 | 6,0 | 0,5 | 2,4 | 14,5 | 21 | 38 | 9500 | 85 | 2986 | 93,0 | 94,6 | 95,3 | 0,82 | 0,88 | 0,89 | 48,3 |
| 800 | 1080 | W22Xd 560H/G | 2559 | 6,0 | 0,5 | 2,4 | 15,9 | 19 | 35 | 10200 | 85 | 2986 | 93,7 | 95,0 | 95,6 | 0,83 | 0,88 | 0,90 | 53,7 |
| 900 | 1215 | W22Xd 560H/G | 2878 | 6,0 | 0,5 | 2,4 | 17,4 | 17 | 33 | 10600 | 85 | 2986 | 93,7 | 95,0 | 95,6 | 0,83 | 0,88 | 0,90 | 60,4 |
| 1000 | 1350 | W22Xd 560H/G | 3197 | 6,2 | 0,6 | 2,5 | 18,8 | 12 | 25 | 11000 | 85 | 2987 | 93,8 | 95,2 | 95,8 | 0,83 | 0,88 | 0,90 | 67,0 |
| 1120 | 1515 | W22Xd 630K/J | 3575 | 6,0 | 0,4 | 2,4 | 22,1 | 19 | 40 | 11200 | 85 | 2992 | 91,6 | 93,7 | 94,8 | 0,81 | 0,87 | 0,88 | 77,5 |
| 1250 | 1690 | W22Xd 630J/H | 3990 | 6,0 | 0,4 | 2,4 | 24,0 | 15 | 32 | 11900 | 85 | 2992 | 92,2 | 94,2 | 95,1 | 0,81 | 0,87 | 0,88 | 86,2 |
| 1400 | 1890 | W22Xd 630J/H | 4469 | 6,5 | 0,5 | 2,4 | 26,0 | 12 | 26 | 12250 | 85 | 2992 | 92,9 | 94,6 | 95,5 | 0,81 | 0,87 | 0,88 | 96,2 |
| 1600 | 2160 | W22Xd 710K/J | 5112 | 6,0 | 0,4 | 2,4 | 30,8 | 11 | 32 | 13000 | 87 | 2989 | 92,4 | 94,2 | 95,0 | 0,80 | 0,87 | 0,90 | 108 |
| 1800 | 2430 | W22Xd 710K/J | 5751 | 6,0 | 0,4 | 2,4 | 41,8 | 11 | 32 | 14200 | 87 | 2989 | 93,0 | 94,7 | 95,4 | 0,80 | 0,87 | 0,90 | 121 |
| IV Pole - 1500 min⁻¹ | | | | | | | | | | | | | | | | | | | |
| 900 | 1215 | W22Xd 560J/H | 5765 | 5,5 | 0,4 | 2,0 | 30,6 | 12 | 33 | 10600 | 84 | 1491 | 95,3 | 96,0 | 96,1 | 0,84 | 0,88 | 0,88 | 61,4 |
| 1000 | 1350 | W22Xd 560H/G | 6405 | 5,5 | 0,4 | 2,0 | 32,9 | 12 | 33 | 11500 | 84 | 1491 | 95,6 | 96,2 | 96,2 | 0,84 | 0,88 | 0,88 | 68,2 |
| 1120 | 1515 | W22Xd 560H/G | 7174 | 5,5 | 0,4 | 2,0 | 35,2 | 11 | 30 | 11800 | 84 | 1491 | 95,8 | 96,4 | 96,4 | 0,85 | 0,88 | 0,88 | 76,2 |
| 1250 | 1690 | W22Xd 630K/J | 7985 | 5,5 | 0,4 | 1,8 | 69,4 | 14 | 40 | 12000 | 85 | 1495 | 93,8 | 94,9 | 95,3 | 0,85 | 0,88 | 0,88 | 86,1 |
| 1400 | 1890 | W22Xd 630J/H | 8943 | 5,5 | 0,4 | 1,8 | 74,6 | 13 | 36 | 12400 | 85 | 1495 | 94,2 | 95,3 | 95,6 | 0,84 | 0,88 | 0,88 | 96,1 |
| 1600 | 2160 | W22Xd 630J/H | 10221 | 5,5 | 0,4 | 1,8 | 79,8 | 11 | 31 | 13600 | 85 | 1495 | 94,5 | 95,5 | 95,8 | 0,84 | 0,88 | 0,88 | 110 |
| 1800 | 2430 | W22Xd 710J/H | 11506 | 5,5 | 0,4 | 2,0 | 95,2 | 15 | 36 | 13900 | 86 | 1494 | 94,4 | 95,5 | 96,0 | 0,83 | 0,88 | 0,88 | 123 |
| 2000 | 2705 | W22Xd 710J/H | 12784 | 5,5 | 0,4 | 2,0 | 101 | 14 | 33 | 14400 | 86 | 1494 | 94,8 | 95,8 | 96,2 | 0,84 | 0,88 | 0,88 | 136 |
| 2250 | 3040 | W22Xd 710J/H | 14383 | 5,5 | 0,4 | 2,0 | 108 | 13 | 30 | 14750 | 86 | 1494 | 95,1 | 96,0 | 96,3 | 0,84 | 0,88 | 0,88 | 153 |
| 2500 | 3380 | W22Xd 710J/H | 15981 | 5,5 | 0,4 | 2,0 | 114 | 12 | 28 | 14900 | 86 | 1494 | 95,3 | 96,1 | 96,3 | 0,85 | 0,88 | 0,88 | 170 |
| 2800 | 3785 | W22Xd 710J/H | 17898 | 5,5 | 0,4 | 2,0 | 120 | 11 | 26 | 15150 | 86 | 1494 | 95,6 | 96,4 | 96,5 | 0,86 | 0,88 | 0,88 | 190 |
| 3150 | 4255 | W22Xd 710H/G | 20136 | 5,5 | 0,4 | 2,0 | 145 | 10 | 26 | 15900 | 86 | 1494 | 95,6 | 96,3 | 96,5 | 0,85 | 0,88 | 0,89 | 212 |
| 3550 | 4795 | W22Xd 710H/G | 22692 | 5,5 | 0,4 | 2,0 | 158 | 10 | 24 | 16200 | 86 | 1494 | 95,6 | 96,3 | 96,5 | 0,86 | 0,89 | 0,89 | 239 |

W22Xd Tube-Cooled Series / Standard - Anti-friction bearings and Sleeve Bearings arrangement

| Output | | Frame IEC | T _n (Nm) | I _s / I _n | T _s / T _n | T _{max} / T _n | Inertia J (Kgm ²) | Allowable locked rotor time Hot/Cold (s) | Weight (Kg) | Sound Pressure dB(A) | RPM | Y 10000V/50Hz | | | | | | I _n (A) |
|--------|----|-----------|---------------------|---------------------------------|---------------------------------|-----------------------------------|-------------------------------|--|-------------|----------------------|-----|----------------|--|--|--------------------|--|--|--------------------|
| kW | HP | | | | | | | | | | | % of full load | | | | | | |
| | | | | | | | | | | | | Efficiency η | | | Power Factor Cos φ | | | |
| | | 50 | 75 | 100 | 50 | 75 | 100 | | | | | | | | | | | |

VI Pole - 1000 min⁻¹

| | | | | | | | | | | | | | | | | | | | |
|------|------|--------------|-------|-----|-----|-----|------|----|----|-------|----|-----|------|------|------|------|------|------|------|
| 630 | 850 | W22Xd 560J/H | 6047 | 6,0 | 0,7 | 2,5 | 62,7 | 16 | 37 | 10700 | 82 | 995 | 94,3 | 95,2 | 95,4 | 0,77 | 0,83 | 0,86 | 44,3 |
| 710 | 960 | W22Xd 560J/H | 6815 | 6,0 | 0,7 | 2,5 | 66,8 | 15 | 37 | 11000 | 82 | 995 | 94,3 | 95,2 | 95,4 | 0,78 | 0,84 | 0,86 | 50,0 |
| 800 | 1080 | W22Xd 560H/G | 7678 | 6,0 | 0,7 | 2,5 | 75,1 | 12 | 35 | 12000 | 82 | 995 | 94,3 | 95,2 | 95,4 | 0,78 | 0,84 | 0,86 | 56,3 |
| 900 | 1215 | W22Xd 630K/J | 8638 | 5,5 | 0,5 | 2,1 | 73,2 | 16 | 40 | 12500 | 83 | 995 | 94,4 | 95,3 | 95,6 | 0,79 | 0,84 | 0,86 | 63,2 |
| 1000 | 1350 | W22Xd 630K/J | 9598 | 5,5 | 0,5 | 2,1 | 79,2 | 15 | 40 | 12800 | 83 | 995 | 94,4 | 95,3 | 95,6 | 0,79 | 0,84 | 0,86 | 70,2 |
| 1120 | 1515 | W22Xd 630K/J | 10750 | 5,5 | 0,5 | 2,1 | 85,1 | 14 | 36 | 13100 | 83 | 995 | 94,5 | 95,5 | 95,8 | 0,79 | 0,84 | 0,86 | 78,5 |
| 1250 | 1690 | W22Xd 630J/H | 11997 | 5,5 | 0,5 | 2,1 | 91,1 | 13 | 33 | 13800 | 83 | 995 | 94,5 | 95,5 | 95,8 | 0,79 | 0,84 | 0,86 | 87,6 |
| 1400 | 1890 | W22Xd 710J/H | 13437 | 5,5 | 0,5 | 2,1 | 151 | 16 | 38 | 13900 | 85 | 995 | 94,8 | 95,7 | 96,0 | 0,80 | 0,84 | 0,86 | 97,9 |
| 1600 | 2160 | W22Xd 710J/H | 15357 | 5,5 | 0,5 | 2,1 | 171 | 16 | 38 | 14300 | 85 | 995 | 94,8 | 95,7 | 96,0 | 0,80 | 0,84 | 0,86 | 112 |
| 1800 | 2430 | W22Xd 710J/H | 17276 | 5,5 | 0,5 | 2,1 | 191 | 15 | 37 | 14800 | 85 | 995 | 95,0 | 95,9 | 96,2 | 0,81 | 0,85 | 0,87 | 124 |
| 2000 | 2705 | W22Xd 710J/H | 19196 | 5,5 | 0,5 | 2,1 | 200 | 14 | 35 | 15300 | 85 | 995 | 95,0 | 95,9 | 96,2 | 0,81 | 0,85 | 0,87 | 138 |
| 2250 | 3040 | W22Xd 710H/G | 21574 | 6,0 | 0,5 | 2,2 | 240 | 14 | 35 | 16000 | 85 | 996 | 95,1 | 96,0 | 96,4 | 0,81 | 0,86 | 0,88 | 153 |
| 2500 | 3380 | W22Xd 710H/G | 23971 | 6,5 | 0,6 | 2,4 | 260 | 11 | 26 | 16300 | 85 | 996 | 95,2 | 96,1 | 96,5 | 0,81 | 0,86 | 0,88 | 170 |

VIII Pole - 750 min⁻¹

| | | | | | | | | | | | | | | | | | | | |
|------|------|--------------|-------|-----|-----|-----|------|----|----|-------|----|-----|------|------|------|------|------|------|------|
| 500 | 675 | W22Xd 560J/H | 6418 | 5,0 | 0,5 | 2,1 | 47,9 | 16 | 38 | 11000 | 82 | 744 | 93,4 | 94,2 | 94,3 | 0,73 | 0,80 | 0,82 | 37,3 |
| 560 | 755 | W22Xd 560H/G | 7188 | 5,0 | 0,5 | 2,1 | 54,2 | 16 | 38 | 11700 | 82 | 744 | 93,4 | 94,2 | 94,3 | 0,73 | 0,80 | 0,82 | 41,8 |
| 630 | 850 | W22Xd 630K/J | 8076 | 5,0 | 0,5 | 2,0 | 75,0 | 17 | 40 | 12200 | 82 | 745 | 93,6 | 94,6 | 94,8 | 0,74 | 0,81 | 0,83 | 46,2 |
| 710 | 960 | W22Xd 630K/J | 9101 | 5,0 | 0,5 | 2,0 | 80,6 | 17 | 40 | 12500 | 82 | 745 | 93,8 | 94,8 | 95,0 | 0,74 | 0,81 | 0,83 | 52,0 |
| 800 | 1080 | W22Xd 630K/J | 10255 | 5,0 | 0,5 | 2,0 | 86,3 | 15 | 36 | 12800 | 82 | 745 | 93,8 | 94,8 | 95,0 | 0,74 | 0,81 | 0,83 | 58,6 |
| 900 | 1215 | W22Xd 630K/J | 11537 | 5,0 | 0,5 | 2,0 | 97,6 | 15 | 36 | 13100 | 82 | 745 | 94,0 | 95,0 | 95,2 | 0,74 | 0,81 | 0,83 | 65,8 |
| 1000 | 1350 | W22Xd 630J/H | 12819 | 5,0 | 0,5 | 2,0 | 103 | 14 | 32 | 13800 | 82 | 745 | 94,2 | 95,1 | 95,3 | 0,74 | 0,81 | 0,83 | 73,0 |
| 1120 | 1515 | W22Xd 710J/H | 14319 | 6,0 | 0,6 | 2,3 | 171 | 16 | 40 | 13900 | 84 | 747 | 94,4 | 95,3 | 95,5 | 0,74 | 0,81 | 0,84 | 80,6 |
| 1250 | 1690 | W22Xd 710J/H | 15981 | 6,0 | 0,6 | 2,3 | 181 | 14 | 35 | 14300 | 84 | 747 | 94,4 | 95,3 | 95,5 | 0,74 | 0,81 | 0,84 | 90,0 |
| 1400 | 1890 | W22Xd 710J/H | 17898 | 6,0 | 0,6 | 2,3 | 200 | 14 | 35 | 14800 | 84 | 747 | 94,5 | 95,4 | 95,6 | 0,74 | 0,81 | 0,84 | 101 |
| 1600 | 2160 | W22Xd 710J/H | 20455 | 6,0 | 0,6 | 2,3 | 220 | 12 | 32 | 15300 | 84 | 747 | 94,5 | 95,5 | 95,8 | 0,74 | 0,81 | 0,84 | 115 |
| 1800 | 2430 | W22Xd 710H/G | 23012 | 6,0 | 0,6 | 2,3 | 250 | 12 | 32 | 16000 | 84 | 747 | 94,6 | 95,6 | 96,0 | 0,74 | 0,81 | 0,84 | 129 |
| 2000 | 2705 | W22Xd 710H/G | 25569 | 6,5 | 0,7 | 2,4 | 280 | 10 | 25 | 16300 | 84 | 747 | 94,6 | 95,6 | 96,0 | 0,74 | 0,81 | 0,84 | 143 |

T_n = Full load torque
 I_s / I_n = Locked rotor current
 T_s / T_n = Locked rotor torque
 T_{max} / T_n = Breakdown torque
 I_n = Full load current

Notes:
 - All motors with copper rotor
 - The indicated values for sound pressure levels are @ 1m no load, with 3 dB(A) tolerance.
 - All values are according to IEC 60034-1 Standard tolerances.
 - This data can be changed without prior notice.

6.2.3. Medium Voltage - Mechanical Data (1100V < U ≤ 6600V)

W22Xd Tube-Cooled Series

560 - 630 - 710, IMB3L
Standard - Anti-friction bearings

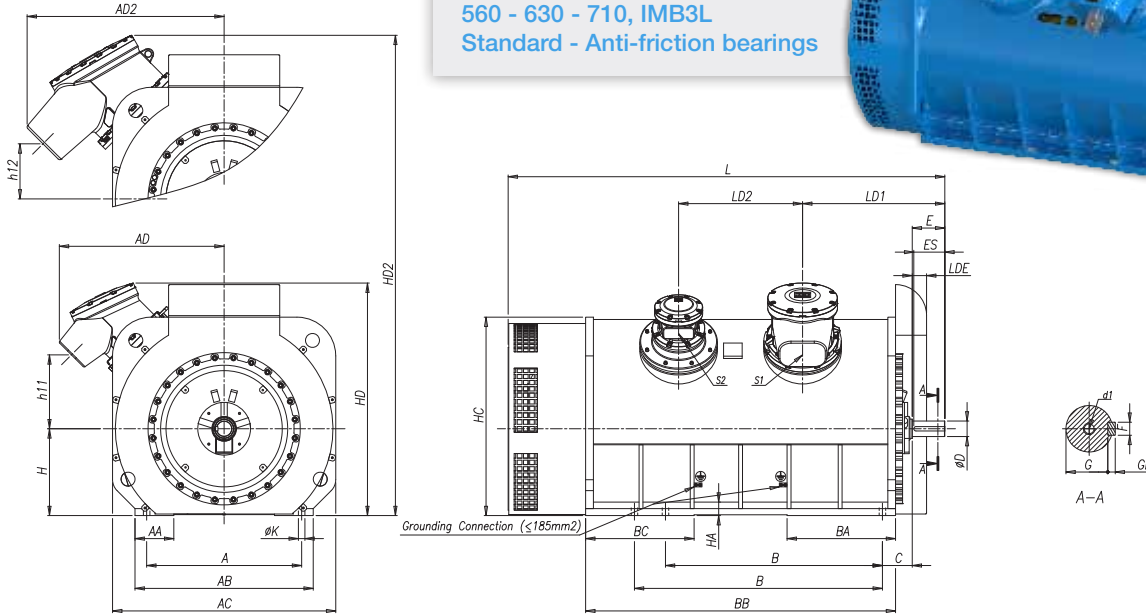

| Frame | Poles | A | AA | AB | AC | AD ⁽¹⁾ | BA | BB | BC | B | C | H | HA | HC | HD ⁽¹⁾ | h11 ⁽¹⁾ | K | L | LD1 | LD2 | LDE |
|--------|-------|------|-----|------|------|-------------------|-----|------|-----|------|------|------|----|------|-------------------|--------------------|----|------|-----|------|-----|
| 560J/H | 2P | 1000 | 280 | 1200 | 1480 | 1065 | 700 | 1950 | 700 | 1250 | 250 | 560 | 45 | 1280 | 1500 | 477 | 42 | 2875 | 925 | 750 | 135 |
| | 1400 | | | | | | | | | 2915 | | | | | | | | 965 | | | |
| 560H/G | 2P | | | | | | | | | 2050 | 1400 | 1600 | | | | | | 2975 | 950 | 800 | |
| | 4P+ | | | | | | | | | 3015 | 990 | 800 | | | | | | | | | |
| 630K/J | 2P | 1120 | 280 | 1320 | 1580 | 1130 | 700 | 1950 | 700 | 1250 | 280 | 630 | 45 | 1420 | 1637 | 546 | 42 | 2925 | 925 | 750 | 135 |
| | 1400 | | | | | | | | | 2965 | | | | | | | | 965 | | | |
| 630J/H | 2P | | | | | | | | | 2050 | 1400 | 1600 | | | | | | 3025 | 950 | 800 | |
| | 4P+ | | | | | | | | | 3065 | 990 | 800 | | | | | | | | | |
| 710K/J | 2P | 1250 | 280 | 1450 | 1730 | 1194 | 700 | 2050 | 700 | 1400 | 315 | 710 | 45 | 1575 | 1780 | 610 | 42 | 3075 | 975 | 750 | 135 |
| 710J/H | 2P | | | | | | | | | 1600 | | | | | | | | 315 | 710 | 3465 | |
| | 4P+ | | | | | | | | | 1800 | 3765 | 1065 | | | | | | | | 1350 | |
| 710H/G | 4P+ | | | | | | | | | 2650 | 1800 | 2000 | | | | | | | | | |

| Frame | Poles | Shaft dimensions | | | | | | | Bearings | | Power terminal box - S1 ⁽¹⁾ | Auxiliary terminal box - S2 |
|--------|-------|------------------|-----|-----|------|-----|----|-------|----------------|---------|--|-----------------------------|
| | | D | E | ES | F | G | GD | d1 | D.E. | N.D.E. | WTBX M | WTBX S |
| 560J/H | 2P | 100m6 | 210 | 200 | 28h9 | 90 | 16 | DSM24 | NU220C3+6020C3 | NU220C3 | ≤315A : 1xM63x1,5 315A<l≤630A : 3xM63x1,5 | 3xM20x1,5 |
| | 4P+ | 140m6 | 250 | 240 | 36h9 | 128 | 20 | DSM30 | 6330C3 | 6330C3 | | |
| 560H/G | 2P | 100m6 | 210 | 200 | 28h9 | 90 | 16 | DSM24 | NU220C3+6020C3 | NU220C3 | | |
| | 4P+ | 140m6 | 250 | 240 | 36h9 | 128 | 20 | DSM30 | 6330C3 | 6330C3 | | |
| 630K/J | 2P | 100m6 | 210 | 200 | 28h9 | 90 | 16 | DSM24 | NU220C3+6020C3 | NU220C3 | | |
| | 4P+ | 150m6 | 250 | 240 | 36h9 | 138 | 20 | DSM30 | 6332C3 | 6332C3 | | |
| 630J/H | 2P | 100m6 | 210 | 200 | 28h9 | 90 | 16 | DSM24 | NU220C3+6020C3 | NU220C3 | | |
| | 4P+ | 150m6 | 250 | 240 | 36h9 | 138 | 20 | DSM30 | 6332C3 | 6332C3 | | |
| 710K/J | 2P | 100m6 | 210 | 200 | 28h9 | 90 | 16 | DSM24 | NU220C3+6020C3 | NU220C3 | | |
| 710J/H | 4P+ | 160m6 | 300 | 290 | 40h9 | 147 | 22 | DSM30 | NU234C3+6034C3 | NU326C3 | | |
| | | 180m6 | | | 45h9 | 165 | 25 | DSM36 | NU238C3+6038C3 | NU326C3 | | |

Notes:

(1) l ≤ 630A
All the dimensions are in millimeters.
Please, do not use these dimensions for construction. Certified drawings under request.
External thrust shall be informed at the time of Inquiry/Order.
Execution with second shaft end is optional and available under request.
For other special executions please refer to us.
The dimensions shown are subject to change without prior notice.

| Frame | AD2 | HD2 | h12 | Power terminal box - WTBX L - S1 |
|-------|------|------|-----|----------------------------------|
| 560 | 1269 | 1614 | 354 | 630A < l ≤ 1260A : 6xM63x1,5 |
| 630 | 1334 | 1751 | 421 | |
| 710 | 1398 | 1894 | 483 | |



W22Xd Tube-Cooled Series
560 - 630 - 710, IMV1
Standard - Anti-friction bearings

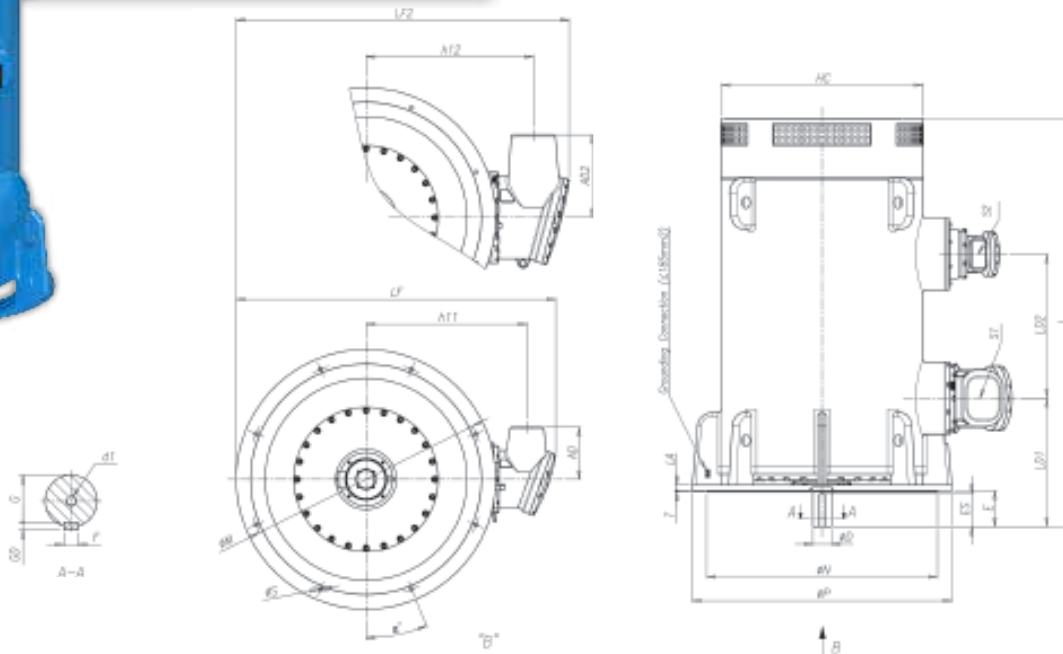

| Frame | Poles | AD ⁽¹⁾ | HC | h11 ⁽¹⁾ | L | LA | LD1 | LD2 | LF ⁽¹⁾ | M | N | P | T | S | Nr. Holes | α |
|--------|-------|-------------------|------|--------------------|------|----|------|------|-------------------|------|------|------|---|----|-----------|----------|
| 560J/H | 4P+ | 360 | 1480 | 1034 | 2915 | 40 | 965 | 750 | 2215 | 1500 | 1400 | 1600 | 8 | 28 | 12 | 15° |
| 560H/G | 4P+ | 360 | 1480 | 1034 | 3015 | 40 | 990 | 800 | 2215 | 1500 | 1400 | 1600 | 8 | 28 | 12 | 15° |
| 630K/J | 4P+ | 360 | 1580 | 1204 | 2965 | 40 | 965 | 750 | 1907 | 1700 | 1600 | 1800 | 9 | 28 | 12 | 15° |
| 630J/H | 4P+ | 360 | 1580 | 1204 | 3065 | 40 | 990 | 800 | 1907 | 1700 | 1600 | 1800 | 9 | 28 | 12 | 15° |
| 710J/H | 4P+ | 360 | 1730 | 1344 | 3465 | 50 | 1090 | 1000 | 2126 | 1900 | 1800 | 2000 | 9 | 35 | 12 | 15° |
| 710H/G | 4P+ | 360 | 1730 | 1344 | 3765 | 50 | 1065 | 1350 | 2126 | 1900 | 1800 | 2000 | 9 | 35 | 12 | 15° |

| Frame | Poles | Shaft dimensions | | | | | | | Bearings | | Power terminal box - S ⁽¹⁾ | Auxiliary terminal box - S2 |
|--------|-------|------------------|-----|-----|------|----|-----|-------|----------|--------|--|-----------------------------|
| | | D | E | ES | F | G | GD | d1 | D.E. | N.D.E. | WTBX M | WTBX S |
| 560J/H | 4P+ | 140m6 | 250 | 240 | 36h9 | 20 | 128 | DSM30 | 6330C3 | 7328 | I ≤ 315A : 1xM63x1,5 315A < I ≤ 630A : 3xM63x1,5 | 3xM20x1,5 |
| 560H/G | | | | | | | | | | | | |
| 630K/J | 4P+ | 150m6 | 250 | 240 | 36h9 | 20 | 138 | DSM30 | 6332C3 | 7328 | | |
| 630J/H | | | | | | | | | | | | |
| 710J/H | 4P+ | 160m6 | 300 | 300 | 40h9 | 22 | 147 | DSM30 | 6234C3 | 7234 | | |
| 710H/G | | 180m6 | | | 45h9 | | | | | | | |

| Frame | Poles | AD2 | h12 | LF2 | Power terminal box - WTBX L - S1 |
|-------|-------|-----|------|------|----------------------------------|
| 560 | 4P+ | 575 | 1078 | 2308 | 630A < I ≤ 1260A : 6xM63x1,5 |
| 630 | 4P+ | 575 | 1248 | 2478 | |
| 710 | 4P+ | 575 | 1388 | 2600 | |

Notes:
 (1) I ≤ 630A
 All the dimensions are in millimeters.
 Please, do not use these dimensions for construction. Certified drawings under request.
 External thrust shall be informed at the time of Inquiry/Order.
 For other special executions please refer to us.
 The dimensions shown are subject to change without prior notice.

6.2.4. High Voltage - Mechanical Data (6600V < U ≤ 11000V)

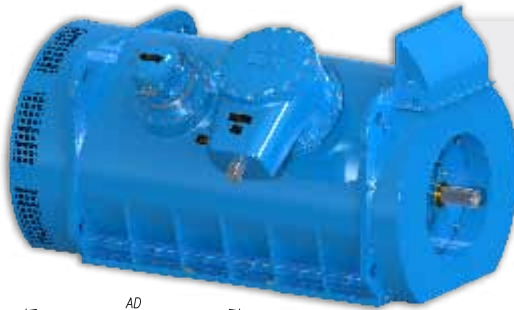

W22Xd Tube-Cooled Series
560 - 630 - 710, IMB3L
Standard - Anti-friction bearings

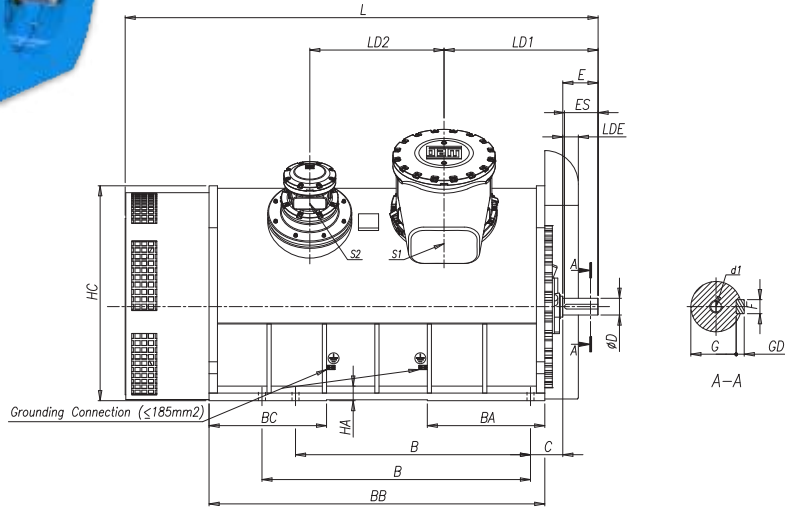
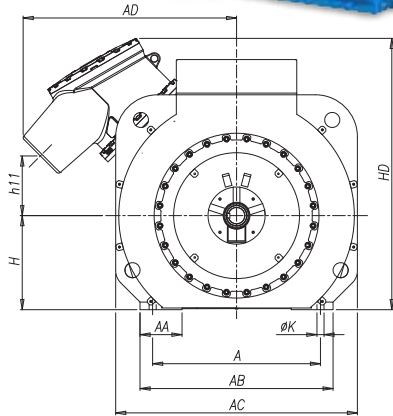

| Frame | Poles | A | AA | AB | AC | AD | BA | BB | BC | B | C | H | HA | HC | HD | h11 | K | L | LD1 | LD2 | LDE |
|--------|-------|------|------|------|------|------|-----|------|-----|------|-----|-----|----|------|------|-----|----|------|------|------|-----|
| 560J/H | 2P | 1000 | | 1200 | 1480 | 1269 | | 1950 | | 1250 | 250 | 560 | | 1280 | 1614 | 354 | | 2875 | 925 | 750 | |
| | 4P+ | | | | | | | | | 1400 | | | | | | | | 2915 | 965 | | |
| 560H/G | 2P | | | | | | | 2050 | | 1400 | | | | | | | | 2975 | 950 | 800 | |
| | 4P+ | | | | | | | | | 1600 | | | | | | | | 3015 | 990 | | |
| 630K/J | 2P | 1120 | 280 | 1320 | 1580 | 1334 | 700 | 1950 | 700 | 1250 | 280 | 630 | 45 | 1420 | 1751 | 421 | 42 | 2925 | 925 | 750 | |
| | 4P+ | | | | | | | | | 1400 | | | | | | | | 2965 | 965 | | |
| 630J/H | 2P | | | | | | | 2050 | | 1400 | | | | | | | | 3025 | 950 | 800 | 135 |
| | 4P+ | | | | | | | | | 1600 | | | | | | | | 3065 | 990 | | |
| 710K/J | 2P | | | | | | | 2050 | | 1400 | | | | | | | | 3075 | 975 | 750 | |
| 710J/H | 4P+ | | | | | | | 1250 | | | | | | | | | | 1450 | 1730 | 1398 | |
| | | 1800 | 3765 | 1065 | 1350 | | | | | | | | | | | | | | | | |
| 710H/G | | | | | | | | 2650 | | 1800 | | | | | | | | 3765 | 1065 | 1350 | |

| Frame | Poles | Shaft dimensions | | | | | | | Bearings | | Power terminal box - S1 | Auxiliary terminal box - S2 |
|--------|-------|------------------|-----|-----|------|-----|----|-------|----------------|---------|--|-----------------------------|
| | | D | E | ES | F | G | GD | d1 | D.E. | N.D.E. | WTBX L | WTBX S |
| 560J/H | 2P | 100m6 | 210 | 200 | 28h9 | 90 | 16 | DSM24 | NU220C3+6020C3 | NU220C3 | I ≤ 200A : 1xM63x1,5 200A < I ≤ 400A : 3xM50x1,5 | 3xM20x1,5 |
| | 4P+ | 140m6 | 250 | 240 | 36h9 | 128 | 20 | DSM30 | 6330C3 | 6330C3 | | |
| 560H/G | 2P | 100m6 | 210 | 200 | 28h9 | 90 | 16 | DSM24 | NU220C3+6020C3 | NU220C3 | | |
| | 4P+ | 140m6 | 250 | 240 | 36h9 | 128 | 20 | DSM30 | 6330C3 | 6330C3 | | |
| 630K/J | 2P | 100m6 | 210 | 200 | 28h9 | 90 | 16 | DSM24 | NU220C3+6020C3 | NU220C3 | | |
| | 4P+ | 150m6 | 250 | 240 | 36h9 | 138 | 20 | DSM30 | 6332C3 | 6332C3 | | |
| 630J/H | 2P | 100m6 | 210 | 200 | 28h9 | 90 | 16 | DSM24 | NU220C3+6020C3 | NU220C3 | | |
| | 4P+ | 150m6 | 250 | 240 | 36h9 | 138 | 20 | DSM30 | 6332C3 | 6332C3 | | |
| 710K/J | 2P | 100m6 | 210 | 200 | 28h9 | 90 | 16 | DSM24 | NU220C3+6020C3 | NU220C3 | | |
| 710J/H | 4P+ | 160m6 | 300 | 290 | 40h9 | 147 | 22 | DSM30 | NU234C3+6034C3 | NU326C3 | | |
| 710H/G | | 180m6 | | | 45h9 | 165 | 25 | DSM36 | NU238C3+6038C3 | NU326C3 | | |

Notes:
All the dimensions are in millimeters.
Please, do not use these dimensions for construction. Certified drawings under request.
External thrust shall be informed at the time of Inquiry/Order.
Execution with second shaft end is optional and available under request.
For other special executions please refer to us.
The dimensions shown are subject to change without prior notice.



W22Xd Tube-Cooled Series
 560 - 630 - 710, IMV1
 Standard - Anti-friction bearings

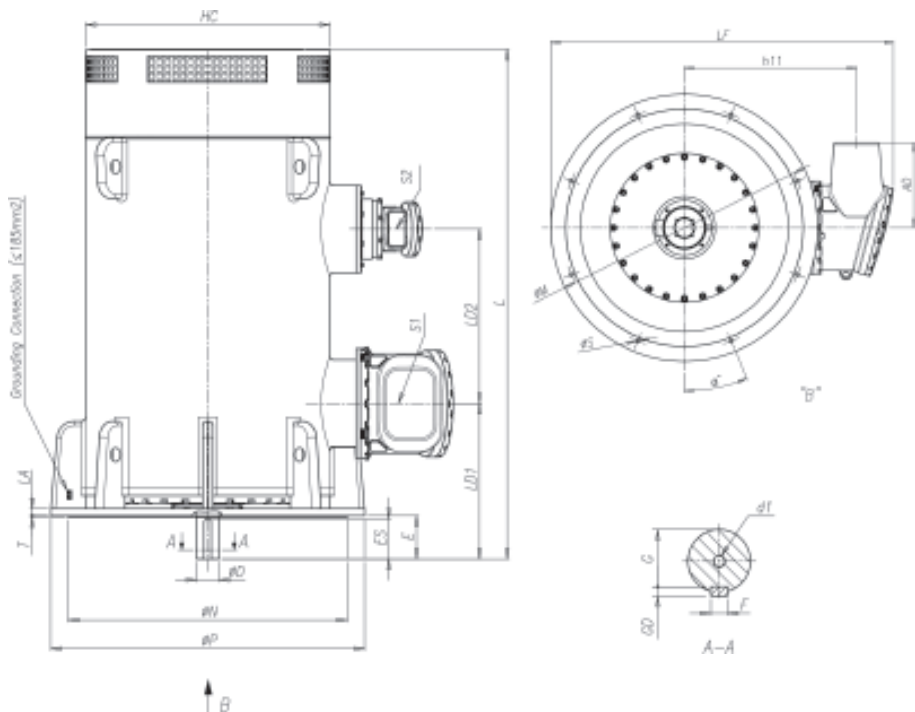

| Frame | Poles | AD | HC | h11 | L | LA | LD1 | LD2 | LF | M | N | P | T | S | Nr. Holes | α |
|--------|-------|-----|------|------|------|----|------|------|------|------|------|------|---|----|-----------|----------|
| 560J/H | 4P+ | 575 | 1480 | 1078 | 2915 | 40 | 965 | 750 | 2308 | 1500 | 1400 | 1600 | 8 | 28 | 12 | 15° |
| 560H/G | 4P+ | 575 | 1480 | 1078 | 3015 | 40 | 990 | 800 | 2308 | 1500 | 1400 | 1600 | 8 | 28 | 12 | 15° |
| 630K/J | 4P+ | 575 | 1580 | 1248 | 2965 | 40 | 965 | 750 | 2478 | 1700 | 1600 | 1800 | 9 | 28 | 12 | 15° |
| 630J/H | 4P+ | 575 | 1580 | 1248 | 3065 | 40 | 990 | 800 | 2478 | 1700 | 1600 | 1800 | 9 | 28 | 12 | 15° |
| 710J/H | 4P+ | 575 | 1730 | 1388 | 3465 | 50 | 1090 | 1000 | 2600 | 1900 | 1800 | 2000 | 9 | 35 | 12 | 15° |
| 710H/G | 4P+ | 575 | 1730 | 1388 | 3765 | 50 | 1065 | 1350 | 2600 | 1900 | 1800 | 2000 | 9 | 35 | 12 | 15° |

| Frame | Poles | Shaft dimensions | | | | | | | Bearings | | Power terminal box - S1 | Auxiliary terminal box - S2 |
|--------|-------|------------------|-----|-----|------|----|-----|-------|----------|--------|------------------------------|-----------------------------|
| | | D | E | ES | F | G | GD | d1 | D.E. | N.D.E. | WTBX L | WTBX S |
| 560J/H | 4P+ | 140m6 | 250 | 240 | 36h9 | 20 | 128 | DSM30 | 6330C3 | 7328 | 630A < l ≤ 1260A : 6xM63x1,5 | 3xM20x1,5 |
| 560H/G | | | | | | | | | | | | |
| 630K/J | 4P+ | 150m6 | 250 | 240 | 36h9 | 20 | 138 | DSM30 | 6332C3 | 7328 | | |
| 630J/H | | | | | | | | | | | | |
| 710J/H | 4P+ | 160m6 | 300 | 300 | 40h9 | 22 | 147 | DSM30 | 6234C3 | 7234 | | |
| 710H/G | | 180m6 | | | 45h9 | | | | | | | |

Notes:
 All the dimensions are in millimeters.
 Please, do not use these dimensions for construction. Certified drawings under request.
 External thrust shall be informed at the time of Inquiry/Order.
 Execution with second shaft end is optional and available under request.
 For other special executions please refer to us.
 The dimensions shown are subject to change without prior notice.

6.2.5. Medium Voltage - Mechanical Data (1100V < U ≤ 6600V)

W22Xd Tube-Cooled Series

560 - 630 - 710, IMB3L
Optional - Sleeve Bearings

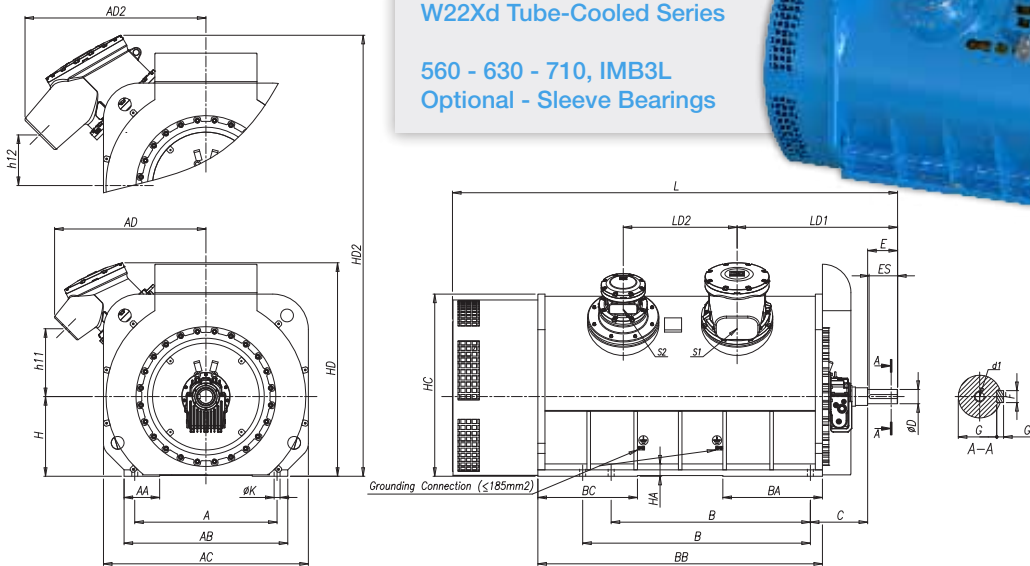

| Frame | Poles | A | AA | AB | AC | AD ⁽¹⁾ | BA | BB | BC | B | C | H | HA | HC | HD ⁽¹⁾ | h11 ⁽¹⁾ | K | L | LD1 | LD2 |
|--------|-------|--------|-----|------|------|-------------------|-----|------|------|------|------|-----|------|------|-------------------|--------------------|----|------|------|------|
| 560J/H | 2P | 1000 | 280 | 1200 | 1480 | 1065 | 700 | 1950 | 700 | 1250 | 440 | 560 | 45 | 1280 | 1500 | 477 | 42 | 3190 | 1115 | 750 |
| | 4P+ | | | | | | | | | 1400 | 465 | | | | | | | | | |
| 560H/G | 2P | 1000 | 280 | 1200 | 1480 | 1065 | 700 | 2050 | 700 | 1400 | 440 | 560 | 45 | 1280 | 1500 | 477 | 42 | 3290 | 1140 | 800 |
| | 4P+ | | | | | | | | | 1600 | 465 | | | | | | | | | |
| 630K/J | 2P | 1120 | 280 | 1320 | 1580 | 1130 | 700 | 1950 | 700 | 1250 | 495 | 630 | 45 | 1420 | 1637 | 546 | 42 | 3265 | 1140 | 750 |
| | 4P+ | | | | | | | | | 1400 | 535 | | | | | | | | | |
| 630J/H | 2P | 1120 | 280 | 1320 | 1580 | 1130 | 700 | 2050 | 700 | 1400 | 495 | 630 | 45 | 1420 | 1637 | 546 | 42 | 3365 | 1165 | 800 |
| | 4P+ | | | | | | | | | 1600 | 535 | | | | | | | | | |
| 710K/J | 2P | 1250 | 280 | 1450 | 1730 | 1194 | 700 | 2050 | 700 | 1400 | 530 | 710 | 45 | 1575 | 1780 | 610 | 42 | 3415 | 1190 | 750 |
| 710J/H | 4P+ | | | | | | | | | 1600 | 570 | | | | | | | | | |
| | | 710H/G | 4P+ | 1800 | 2000 | 570 | 710 | 45 | 1575 | 1780 | 610 | 42 | 3845 | 1345 | 1000 | | | | | |
| 710H/G | 4P+ | 1250 | 280 | 1450 | 1730 | 1194 | 700 | 2650 | 700 | 1800 | 2000 | 570 | 710 | 1575 | 1780 | 610 | 42 | 4145 | 1320 | 1350 |

| Frame | Poles | Shaft dimensions | | | | | | | Bearings | | Power terminal box - S1 ⁽¹⁾ | Auxiliary terminal box - S2 |
|--------|-------|------------------|-----|-----|------|-----|----|-------|--------------|--------------|---|-----------------------------|
| | | D | E | ES | F | G | GD | d1 | D.E. | N.D.E. | WTBX M | WTBX S |
| 560J/H | 2P | 100m6 | 210 | 200 | 28h9 | 90 | 16 | DSM24 | EFNLB 9-90 | EFNLQ 9-90 | I ≤ 315A : 1xM63x1,5 315A < I ≤ 630A : 3xM63x1,5 | 3xM20x1,5 |
| | 4P+ | 140m6 | 250 | 240 | 36h9 | 128 | 20 | DSM30 | EFNLB 11-125 | EFNLQ 11-125 | | |
| 560H/G | 2P | 100m6 | 210 | 200 | 28h9 | 90 | 16 | DSM24 | EFNLB 9-90 | EFNLQ 9-90 | | |
| | 4P+ | 140m6 | 250 | 240 | 36h9 | 128 | 20 | DSM30 | EFNLB 11-125 | EFNLQ 11-125 | | |
| 630K/J | 2P | 100m6 | 210 | 200 | 28h9 | 90 | 16 | DSM24 | EFNLB 11-100 | EFNLQ 11-100 | | |
| | 4P+ | 150m6 | 250 | 240 | 36h9 | 138 | 20 | DSM30 | EFNLB 14-140 | EFNLQ 14-140 | | |
| 630J/H | 2P | 100m6 | 210 | 200 | 28h9 | 90 | 16 | DSM24 | EFNLB 11-100 | EFNLQ 11-100 | | |
| | 4P+ | 150m6 | 250 | 240 | 36h9 | 138 | 20 | DSM30 | EFNLB 14-140 | EFNLQ 14-140 | | |
| 710K/J | 2P | 100m6 | 210 | 200 | 28h9 | 90 | 16 | DSM24 | EFZLB 11-110 | EFZLB 11-110 | | |
| 710J/H | 4P+ | 160m6 | 300 | 290 | 40h9 | 147 | 22 | DSM30 | EFNLB 14-160 | EFNLQ 14-160 | | |
| | | 180m6 | | | 45h9 | 165 | 25 | DSM36 | | | | |

Notes:
 (1) I ≤ 630A
 All the dimensions are in millimeters.
 Please, do not use these dimensions for construction. Certified drawings under request.
 External thrust shall be informed at the time of Inquiry/Order.
 Execution with second shaft end is optional and available under request.
 For other special executions please refer to us.
 The dimensions shown are subject to change without prior notice.
 Rotor is not self-aligned, customer must ensure alignment.
 Over speed not allowed.
 Rotor maximum axial play: ± 3mm.

| Frame | AD2 | HD2 | h12 | Power terminal box - WTBX L - S1 |
|-------|------|------|-----|----------------------------------|
| 560 | 1269 | 1614 | 354 | 630A < I ≤ 1260A : 6xM63x1,5 |
| 630 | 1334 | 1751 | 421 | |
| 710 | 1398 | 1894 | 483 | |

6.2.6. High Voltage - Mechanical Data (6600V < U ≤ 11000V)

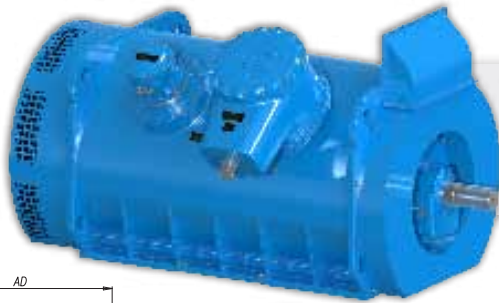

W22Xd Tube-Cooled Series

560 - 630 - 710, IMB3L
Optional - Sleeve Bearings

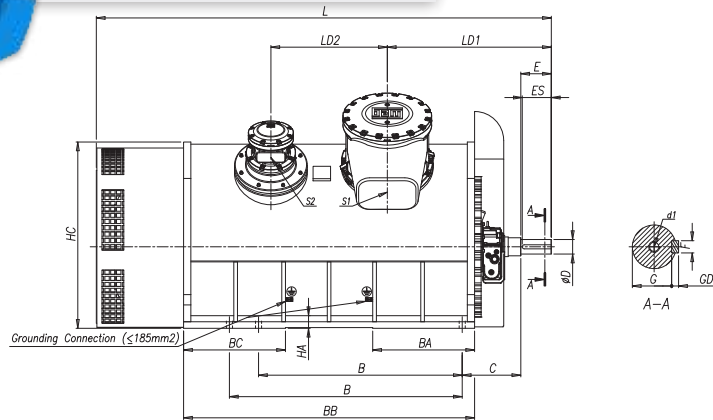
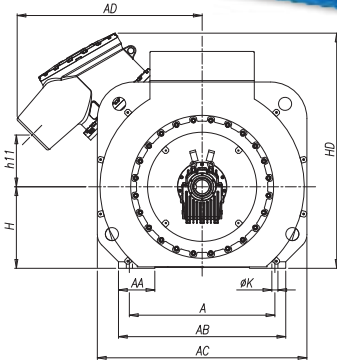

| Frame | Poles | A | AA | AB | AC | AD | BA | BB | BC | B | C | H | HA | HC | HD | h11 | K | L | LD1 | LD2 |
|--------|-------|------|-----|------|------|------|-----|------|-----|------|-----|-----|----|------|------|-----|----|------|------|------|
| 560J/H | 2P | 1000 | 280 | 1200 | 1480 | 1267 | 700 | 1950 | 700 | 1250 | 440 | 560 | 45 | 1280 | 1614 | 354 | 42 | 3190 | 1115 | 750 |
| | 4P+ | | | | | | | | | 1400 | 465 | | | | | | | 3255 | 1180 | |
| 560H/G | 2P | | | | | | | | | 1400 | 440 | | | | | | | 3290 | 1140 | 800 |
| | 4P+ | | | | | | | | | 1600 | 465 | | | | | | | 3355 | 1205 | |
| 630K/J | 2P | 1120 | 280 | 1320 | 1580 | 1334 | 700 | 1950 | 700 | 1250 | 495 | 630 | 45 | 1420 | 1751 | 421 | 42 | 3265 | 1140 | 750 |
| | 4P+ | | | | | | | | | 1400 | 535 | | | | | | | 3345 | 1220 | |
| 630J/H | 2P | | | | | | | | | 1400 | 495 | | | | | | | 3365 | 1165 | 800 |
| | 4P+ | | | | | | | | | 1600 | 535 | | | | | | | 3445 | 1245 | |
| 710K/J | 2P | 1250 | 280 | 1450 | 1730 | 1398 | 700 | 2050 | 700 | 1400 | 530 | 710 | 45 | 1575 | 1894 | 483 | 42 | 3415 | 1190 | 750 |
| 710J/H | 4P+ | | | | | | | | | 1600 | 570 | | | | | | | 3845 | 1345 | 1000 |
| | | | | | | | | | | 1800 | | | | | | | | 4145 | 1320 | 1350 |
| 710H/G | 4P+ | | | | | | | | | 1800 | 570 | | | | | | | 4145 | 1320 | 1350 |

| Frame | Poles | Shaft dimensions | | | | | | | Bearings | | Power terminal box - S1 | Auxiliary terminal box - S2 |
|--------|-------|------------------|-----|-----|------|-----|----|-------|--------------|--------------|---|-----------------------------|
| | | D | E | ES | F | G | GD | d1 | D.E. | N.D.E. | WTBX L | WTBX S |
| 560J/H | 2P | 100m6 | 210 | 200 | 28h9 | 90 | 16 | DSM24 | EFNLB 9-90 | EFNLQ 9-90 | I ≤ 200A : 1xM63x1,5 200A < I ≤ 400A : 3xM50x1,5 | 3xM20x1,5 |
| | 4P+ | 140m6 | 250 | 240 | 36h9 | 128 | 20 | DSM30 | EFNLB 11-125 | EFNLQ 11-125 | | |
| 560H/G | 2P | 100m6 | 210 | 200 | 28h9 | 90 | 16 | DSM24 | EFNLB 9-90 | EFNLQ 9-90 | | |
| | 4P+ | 140m6 | 250 | 240 | 36h9 | 128 | 20 | DSM30 | EFNLB 11-125 | EFNLQ 11-125 | | |
| 630K/J | 2P | 100m6 | 210 | 200 | 28h9 | 90 | 16 | DSM24 | EFNLB 11-100 | EFNLQ 11-100 | | |
| | 4P+ | 150m6 | 250 | 240 | 36h9 | 138 | 20 | DSM30 | EFNLB 14-140 | EFNLQ 14-140 | | |
| 630J/H | 2P | 100m6 | 210 | 200 | 28h9 | 90 | 16 | DSM24 | EFNLB 11-100 | EFNLQ 11-100 | | |
| | 4P+ | 150m6 | 250 | 240 | 36h9 | 138 | 20 | DSM30 | EFNLB 14-140 | EFNLQ 14-140 | | |
| 710K/J | 2P | 100m6 | 210 | 200 | 28h9 | 90 | 16 | DSM24 | EFZLB 11-110 | EFZLB 11-110 | | |
| 710J/H | 4P+ | 160m6 | 300 | 290 | 40h9 | 147 | 22 | DSM30 | EFNLB 14-160 | EFNLQ 14-160 | | |
| 710H/G | | 180m6 | | | 45h9 | 165 | 25 | DSM36 | | | | |

Notes:
 All the dimensions are in millimeters.
 Please, do not use these dimensions for construction. Certified drawings under request.
 External thrust shall be informed at the time of Inquiry/Order.
 Execution with second shaft end is optional and available under request.
 For other special executions please refer to us.
 The dimensions shown are subject to change without prior notice.
 Rotor is not self-aligned, customer must ensure alignment.
 Over speed not allowed.
 Rotor maximum axial play: ± 3mm.

Terminal Boxes

| | |
|--------------------------------------|------------|
| <u>7.1. Power Terminal Boxes</u> | <u>147</u> |
| <u>7.2. Auxiliary Terminal Boxes</u> | <u>158</u> |

7. Terminal Boxes



7.1. Power Terminal Boxes

7.1.1. Technical Data

Flameproof Power Terminal Box - Groups I, II and III
Terminal Box Model: WTBX M
Medium Voltage: 1100V < Un ≤ 6600V

| Protection Level | |
|--------------------------------|---|
| IP66 | |
| Grounding | |
| Quantity | 3 |
| Cross section cables (max.) | 185mm ² |
| Material | Stainless steel |
| Fault level - Optional Feature | |
| Peak | 45kA for 0,25s |
| Cross section cable (min.) | 117kA |
| Bushing and Terminal | 120mm ² |
| | 3 x M16 (I ≤ 400A) 3 x M20 (400A < I ≤ 630A) |



| Current Level | I ≤ 315A | 315A < I ≤ 400A | 400A < I ≤ 630A |
|-----------------------------|---|--|---|
| Entry Holes | 1 x M63 x 1,5 | 3 x M63 x 1,5 | 3 x M63 x 1,5 |
| Cross section cables (max.) | 120mm ² | 500mm ² | 500mm ² |
| Cable Type (max.) | 3 Core - 1x(3x120+1G70) | 1 Core - 3x(1x500) | 1 Core - 3x(1x500) |
| Bushing / Terminal | 3 x M12 | 3 x M16 | 3 x M20 |
| |  |  |  |

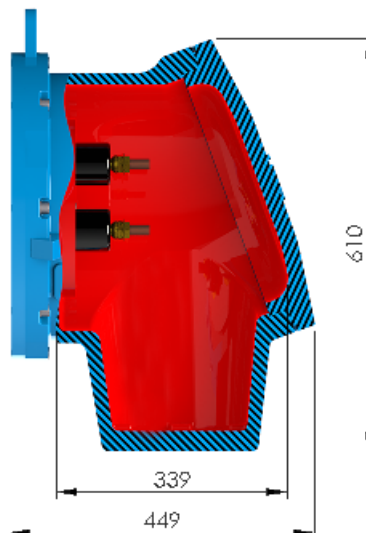
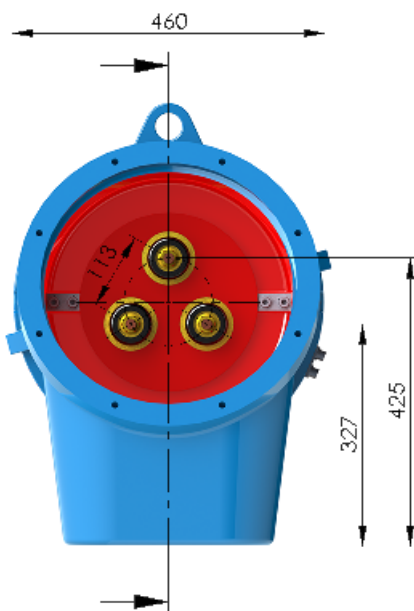

Increased Safety Power Terminal Box - Groups I, II and III
Terminal Box Model: WTBX M
Medium Voltage: 1100V < Un ≤ 6600V

| Protection Level | |
|--------------------------------|---|
| IP66 | |
| Grounding | |
| Quantity | 3 |
| Cross section cables (max.) | 185mm ² |
| Material | Stainless steel |
| Fault level - Optional Feature | |
| Peak | 65kA |
| Cross section cable (min.) | 120mm ² |
| Bushing and Terminal | 3 x M16 (I ≤ 400A) 3 x M20 (400A < I ≤ 630A) |



| Current Level | I ≤ 315A | 315A < I ≤ 400A | 400A < I ≤ 630A |
|-----------------------------|---|---|---|
| Entry Holes | 1 x M63 x 1,5 | 3 x M63 x 1,5 | 3 x M63 x 1,5 |
| Cross section cables (max.) | 95mm ² (1) | 150mm ² (2) | 300mm ² |
| Cable Type (max.) | 3 Core - 1x(3x95+1G50) | 1 Core - 3x(1x150) | 1 Core - 3x(1x300) |
| Bushing / Terminal | 3 x M12 | 3 x M16 | 3 x M20 |
| |  |  |  |

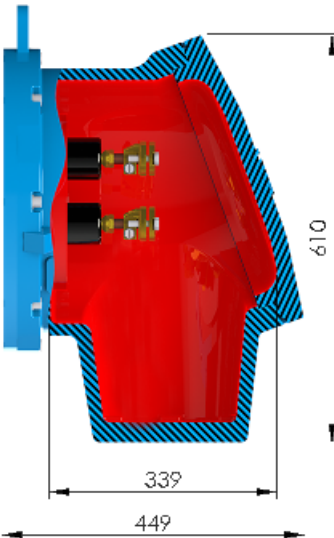
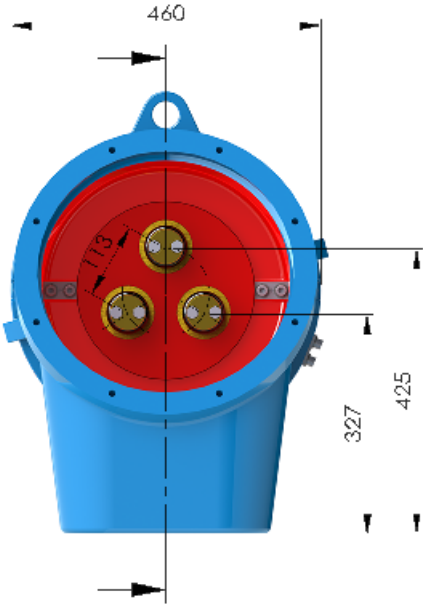

7

Notes:
 (1) As optional can be adapted for a 150mm² cross section cable.
 (2) As optional can be adapted for a 300mm² cross section cable.



Optional Flameproof Power Terminal Box - Groups I, II and III
Terminal Box Model: WTBX L
Medium Voltage: 1100V < Un ≤ 6600V

| Protection Level | |
|------------------|--|
| IP66 | |

| Grounding | |
|-----------------------------|--------------------|
| Quantity | 3 |
| Cross section cables (max.) | 185mm ² |
| Material | Stainless steel |

| Fault level - Optional Feature | |
|--------------------------------|--|
| 45kA for 0,25s | |
| Peak | 117kA |
| Cross section cable (min.) | 120mm ² |
| Bushing and Terminal | 3 x M16 (I ≤ 800A) 3 x M20 (800A < I ≤ 1260A) |



| Current Level | 630A < I ≤ 800A | 800A < I ≤ 1260A |
|-----------------------------|---|---|
| Entry Holes | 6 x M63 x 1,5 | 6 x M63 x 1,5 |
| Cross section cables (max.) | 500mm ² | 500mm ² |
| Cable Type (max.) | 1 Core - 6x(1x500) | 1 Core - 6x(1x500) |
| Bushing / Terminal | 6 x M16 | 6 x M20 |
| |  |  |

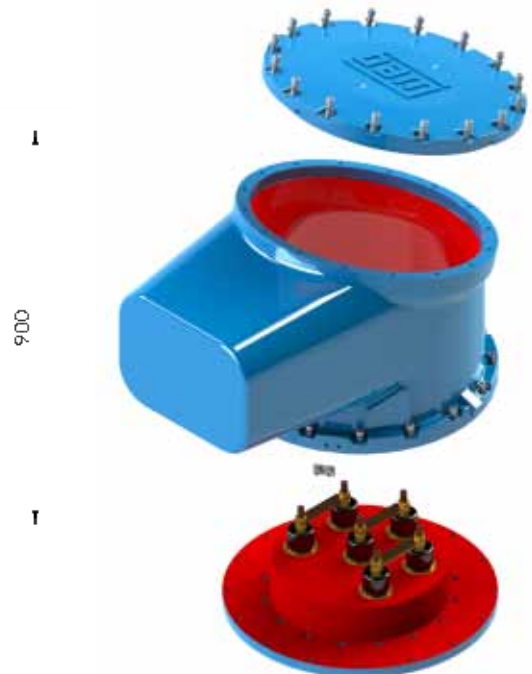
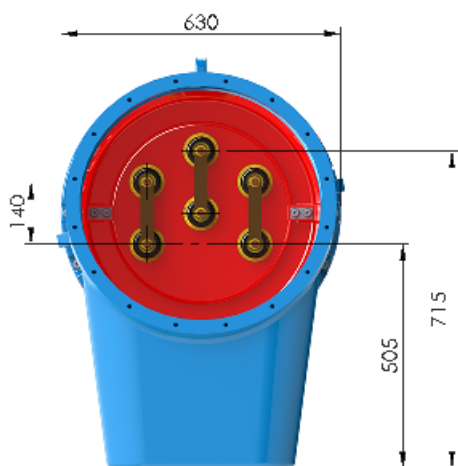



Optional Increased Safety Power Terminal Box - Groups I, II and III
Terminal Box Model: WTBX L
Medium Voltage: 1100V < Un ≤ 6600V

| Protection Level | |
|------------------|--|
| IP66 | |

| Grounding | |
|-----------------------------|--------------------|
| Quantity | 3 |
| Cross section cables (max.) | 185mm ² |
| Material | Stainless steel |

| Fault level - Optional Feature | |
|--------------------------------|--|
| 25kA for 0,25s | |
| Peak | 65kA |
| Cross section cable (min.) | 120mm ² |
| Bushing and Terminal | 3 x M16 (I ≤ 800A) 3 x M20 (800A < I ≤ 1260A) |



| Current Level | 630A < I ≤ 800A | 800A < I ≤ 1260A |
|-----------------------------|--|--|
| Entry Holes | 6 x M63 x 1,5 | 6 x M63 x 1,5 |
| Cross section cables (max.) | 150mm ² (1) | 300mm ² |
| Cable Type (max.) | 1 Core - 6x(1x150) | 1 Core - 6x(1x300) |
| Bushing / Terminal | 6 x M16  | 6 x M20  |

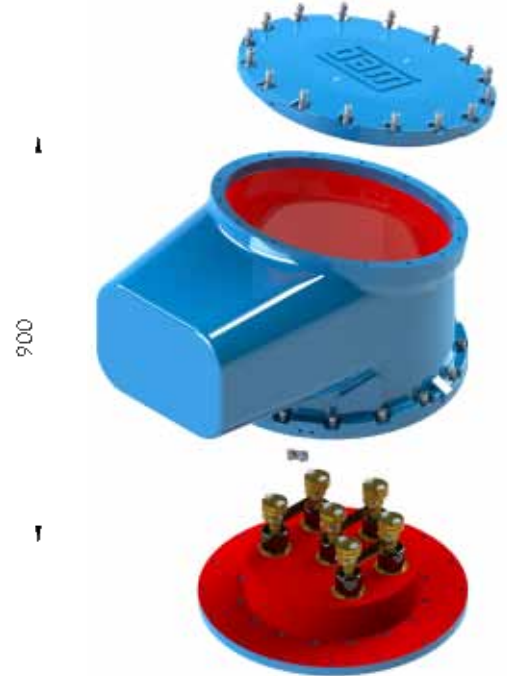
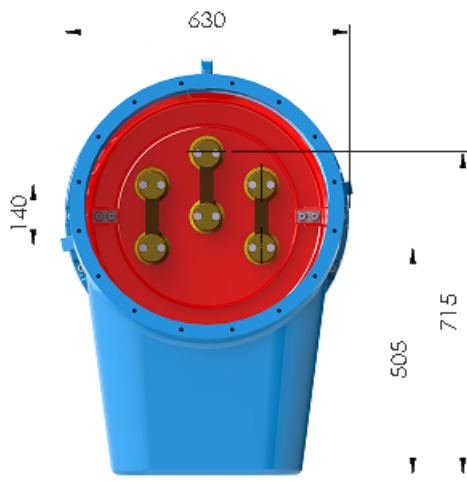

7

Notes:
 (1) As optional can be adapted for a 300mm² cross section cable.



Flameproof Power Terminal Box with Neutral Point - Groups I, II and III
Terminal Box Model: WTBX L
Medium Voltage: 1100V < Un ≤ 6600V

| Protection Level | |
|------------------|--|
| IP66 | |

| Grounding | |
|-----------------------------|--------------------|
| Quantity | 3 |
| Cross section cables (max.) | 185mm ² |
| Material | Stainless steel |

| Fault level - Optional Feature | |
|--------------------------------|---|
| 45kA for 0,25s | |
| Peak | 117kA |
| Cross section cable (min.) | 120mm ² |
| Bushing and Terminal | 3 x M16 (I ≤ 400A) 3 x M20 (400A < I ≤ 630A) |



| Current Level | I ≤ 315A | 315A < I ≤ 400A | 400A < I ≤ 630A |
|-----------------------------|---|---|---|
| Entry Holes | 1 x M63 x 1,5 | 3 x M63 x 1,5 | 3 x M63 x 1,5 |
| Cross section cables (max.) | 120mm ² | 500mm ² | 500mm ² |
| Cable Type (max.) | 3 Core - 1x(3x120+1G70) | 1 Core - 3x(1x500) | 1 Core - 3x(1x500) |
| Bushing / Terminal | 3 x M12 | 3 x M16 | 3 x M20 |
| |  |  |  |

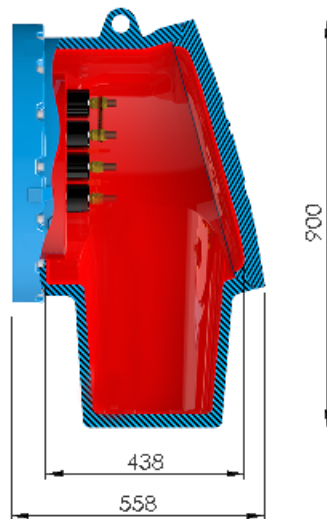
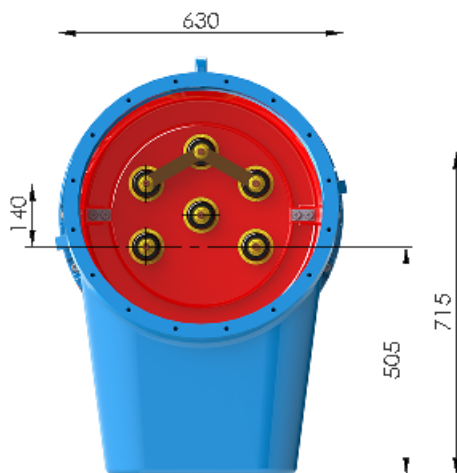

Increased Safety Power Terminal Box with Neutral Point - Groups I, II and III
Terminal Box Model: WTBX L
Medium Voltage: 1100V < Un ≤ 6600V

| Protection Level | |
|--------------------------------|--|
| IP66 | |
| Grounding | |
| Quantity | 3 |
| Cross section cables (max.) | 185mm ² |
| Material | Stainless steel |
| Fault level - Optional Feature | |
| 25kA for 0,25s | |
| Peak | 65kA |
| Cross section cable (min.) | 120mm ² |
| Bushing and Terminal | 3 x M16 (I ≤ 800A) 3 x M20 (800A < I ≤ 1260A) |



| Current Level | I ≤ 315A | 315A < I ≤ 400A | 400A < I ≤ 630A |
|-----------------------------|------------------------|------------------------|--------------------|
| Entry Holes | 1 x M63 x 1,5 | 3 x M63 x 1,5 | 3 x M63 x 1,5 |
| Cross section cables (max.) | 95mm ² (1) | 150mm ² (2) | 300mm ² |
| Cable Type (max.) | 3 Core - 1x(3x95+1G50) | 1 Core - 3x(1x150) | 1 Core - 3x(1x300) |
| Bushing / Terminal | 3 x M12 | 3 x M16 | 3 x M20 |
| | | | |

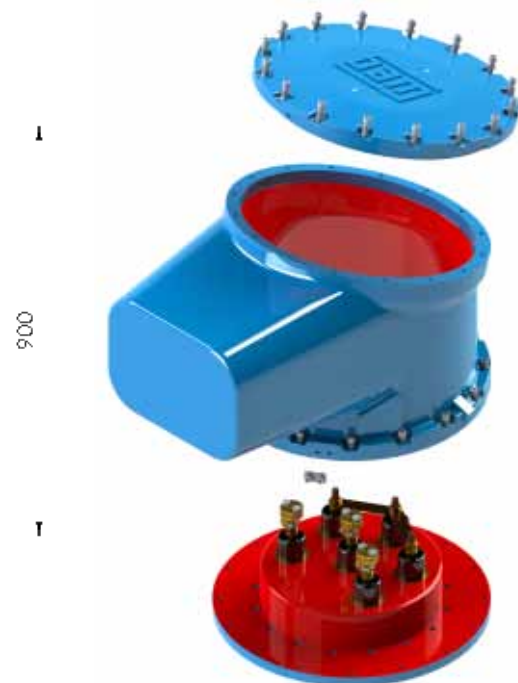
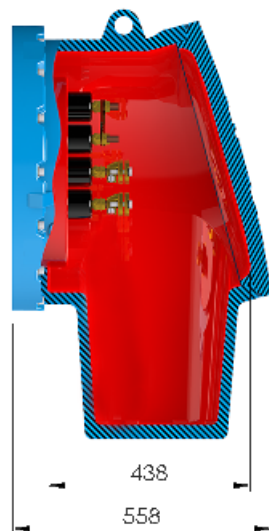
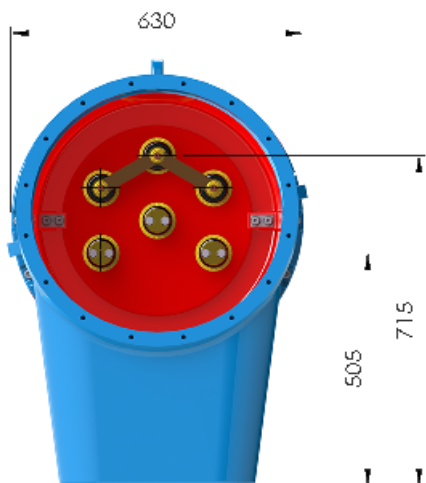



7

Notes:
 (1) As optional can be adapted for a 150mm² cross section cable.
 (2) As optional can be adapted for a 300mm² cross section cable.

Flameproof Power Terminal Box - Groups I, II and III
Terminal Box Model: WTBX L
High Voltage: 6600V < U_n ≤ 11000V

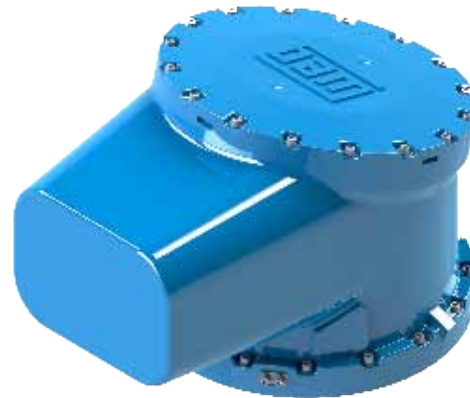
| Protection Level | |
|--------------------------------|--------------------|
| IP66 | |
| Grounding | |
| Quantity | 3 |
| Cross section cables (max.) | 185mm ² |
| Material | Stainless steel |
| Fault level - Optional Feature | |
| Peak | 117kA |
| Cross section cable (min.) | 120mm ² |



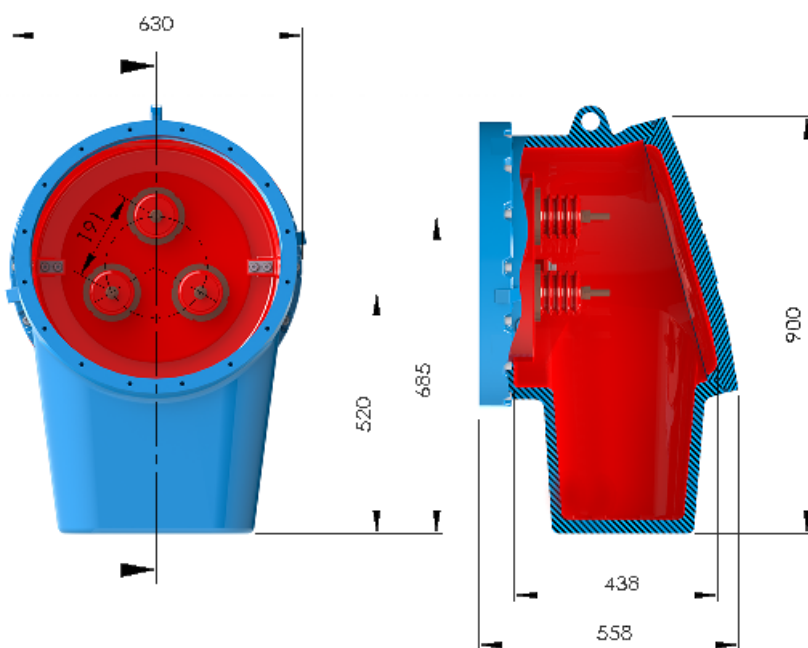

| Current Level | $I \leq 200A$ | $200A < I \leq 400A$ |
|-----------------------------|--|----------------------|
| Entry Holes | 1 x M63 x 1,5 | 3 x M50 x 1,5 |
| Cross section cables (max.) | 50mm ² | 400mm ² |
| Cable Type (max.) | 3 Core - 1x(3x50+1G25) | 1 Core - 3x(1x400) |
| Bushing / Terminal | 3 x M16 | |
| |  | |

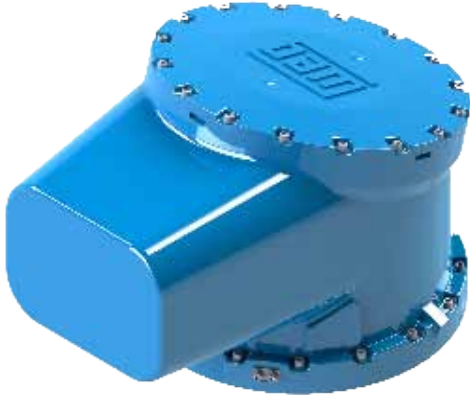

Increased Safety Power Terminal Box - Groups I, II and III
Terminal Box Model: WTBX L
High Voltage: 6600V < Un ≤ 11000V

| Protection Level | |
|--------------------------------|--------------------|
| IP66 | |
| Grounding | |
| Quantity | 3 |
| Cross section cables (max.) | 185mm ² |
| Material | Stainless steel |
| Fault level - Optional Feature | |
| Peak | 65kA |
| Cross section cable (min.) | 120mm ² |



| Current Level | I ≤ 200A | 200A < I ≤ 400A |
|-----------------------------|--|------------------------|
| Entry Holes | 1 x M63 x 1,5 | 3 x M50 x 1,5 |
| Cross section cables (max.) | 150mm ² (1) | 150mm ² (1) |
| Cable Type (max.) | 3 Core - 1x(3x50+1G25) | 1 Core - 3x(1x150) |
| Bushing / Terminal | 3 x M16 | |
| |  | |

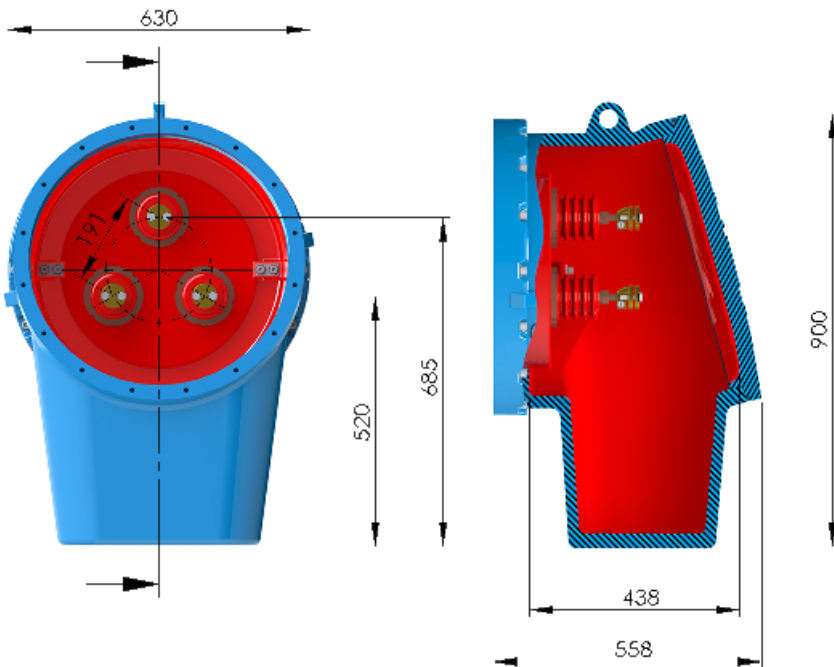

7

Notes: (1) As optional can be adapted for a 300mm² cross section cable.

Phase Insulated Power Terminal Box - Groups I, II and III
Terminal Box Model: WTBX L
Medium and High Voltage: 1100V $U_n \leq 11000V$

| Protection Level | |
|---|---|
| IP66 | |
| Grounding | |
| Quantity | 3 |
| Cross section cables (max.) | 185mm ² |
| Material | Stainless steel |
| Technical Data | |
| Bushing | Euromold connector |
| Fault level - Optional Feature (insulators and accessories) | |
| 50kA for 1s | |
| Peak | 130kA |
| Cross section cable (min.) | from 120mm ² to 300mm ² |



| | |
|-----------------------------|---|
| Current Level | $I \leq 630A$ |
| Entry Holes | 3 x M63 x 1,5 |
| Cross section cables (max.) | 500mm ² |
| Cable Type (max.) | 1 Core - 3x(1x500) |
| Bushing / Terminal |  |

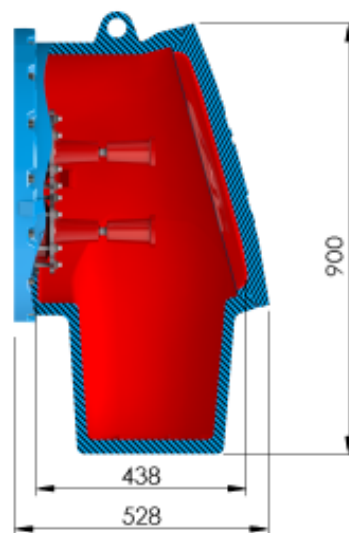
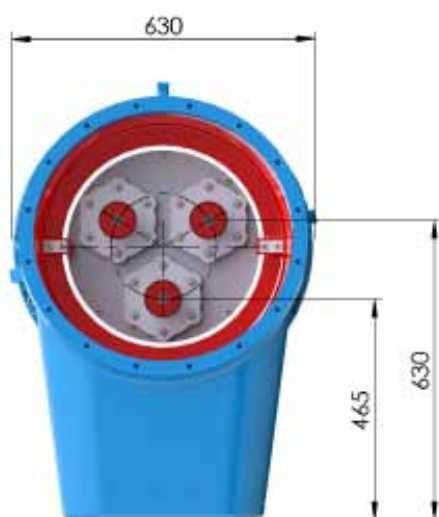

Optional Flameproof Power Terminal Box - Groups I, IIB and III
Terminal Box Model: WTBX XL
Medium and High Voltage: 1100V < Un ≤ 11000V

| Protection Level | |
|------------------|--|
| IP66 | |

| Power Protection Devices <small>(only available for W22Xd tube-cooled motors)</small> | |
|--|--|
| Current Transformers | |
| Partial Discharge Monitoring | |
| Surge Arrestors | |
| Surge Capacitors | |

| Grounding | |
|-----------------------------|--------------------|
| Quantity | 3 |
| Cross section cables (max.) | 185mm ² |
| Material | Stainless steel |

| Fault level - Optional Feature | |
|--------------------------------|---|
| 50kA for 1s / 50kA for 0,25s | |
| Peak | 130kA |
| Cross section cable (min.) | 240mm ² / 185mm ² |

| Terminals | |
|-----------|--|
| 3 x M20 | |

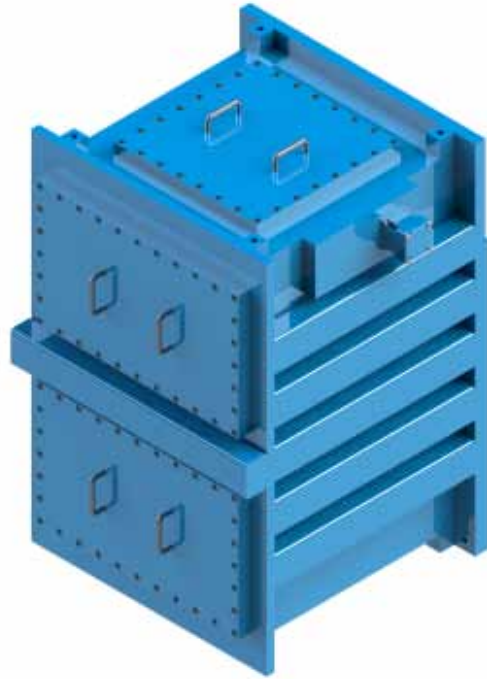

| | |
|-----------------------------|--------------------|
| Current Level | $I \leq 1260A$ |
| Entry Holes | 3 x M63 x 1,5 |
| Cross section cables (max.) | 500mm ² |
| Cable Type (max.) | 1 Core - 3x(1x500) |

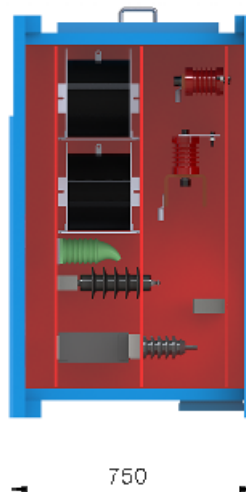
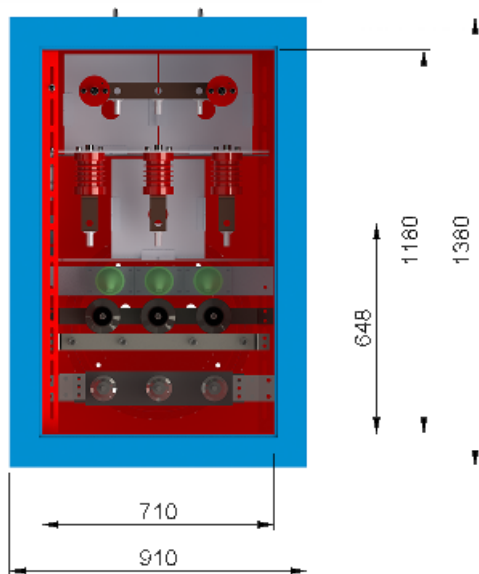

7

7.1.2. Technical Data for Power Protection Equipment

| Current Transformers Differential Protection | |
|--|-------|
| Ratio | 50/5 |
| Burden (VA) | 5 |
| Class | 5P10 |
| Current Transformers (Measurement) | |
| Ratio | 170/1 |
| Burden (VA) | 5 |
| Class | 1 |
| On request different types of Current Transformers can be used | |

| Partial Discharge Monitoring | |
|------------------------------|-----------------|
| Voltage | 6.9kV / 16kV |
| Sensitivity | 1 pC |
| Bandwidth | 40MHz to 350MHz |

| Surge Arrestors | |
|-----------------|-----------------|
| Voltage | 3kV / 6kV / 9kV |

| Surge Capacitors | |
|------------------|----------------------|
| Voltage | 3,3kV / 6,6kV / 11kV |
| Frequency | 50Hz / 60Hz |

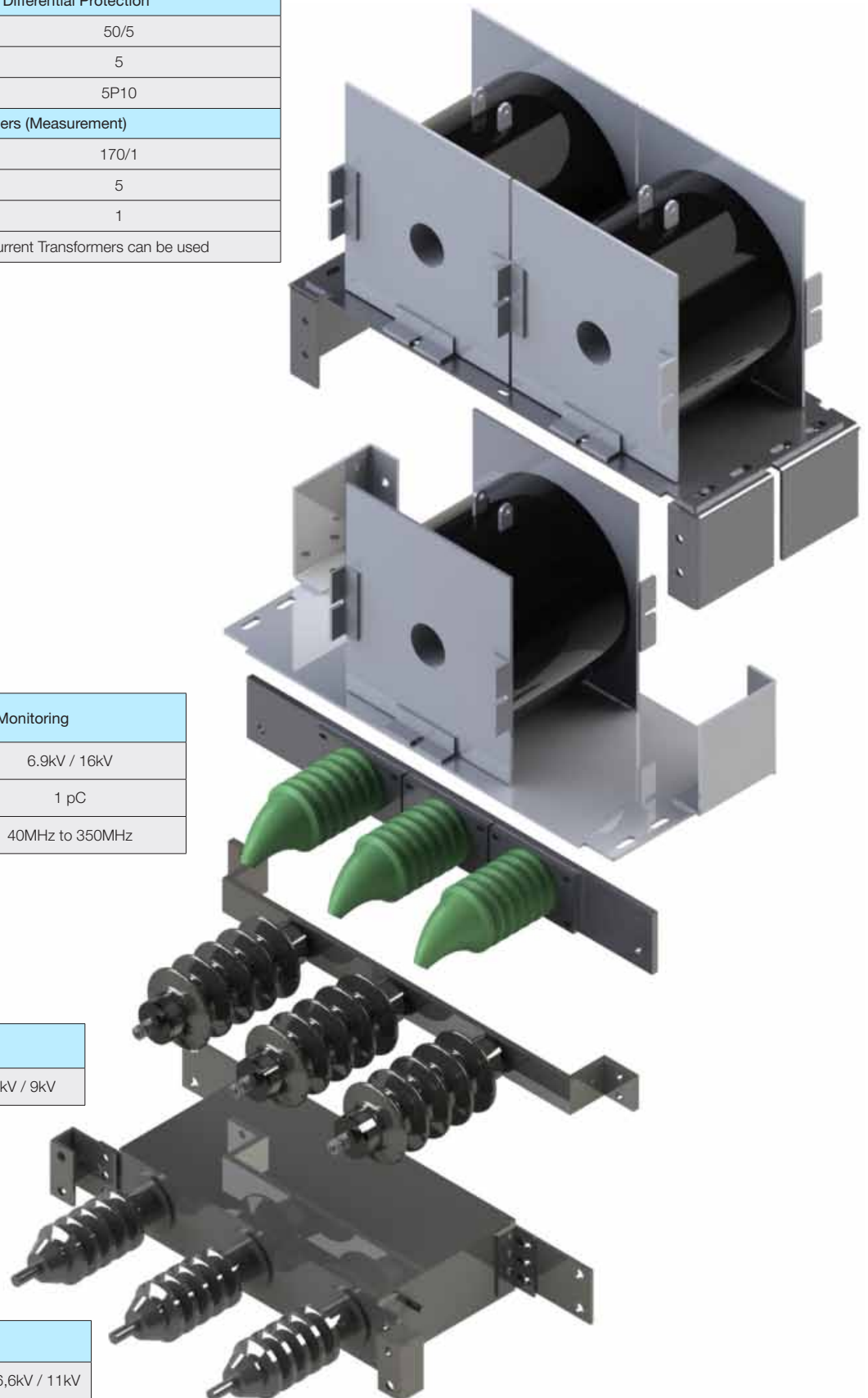

7.2. Auxiliary Terminal Boxes

7.2.1. Neutral Point Terminal Boxes

Flameproof Neutral Point Terminal Box - Groups I, II and III
Terminal Box Model: WTBX M
Medium Voltage: 1100V < Un ≤ 6600V

| Protection Level | |
|-----------------------------|--------------------|
| IP66 | |
| Grounding | |
| Quantity | 3 |
| Cross section cables (max.) | 185mm ² |
| Material | Stainless steel |



| Current Level | $I \leq 315A$ | $315A < I \leq 400A$ | $400A < I \leq 630A$ |
|--------------------|---------------|----------------------|----------------------|
| | 3 x M12 | 3 x M16 | 3 x M20 |
| Bushing / Terminal | | | |

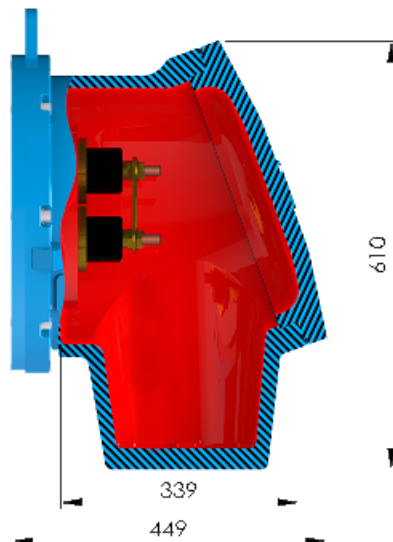
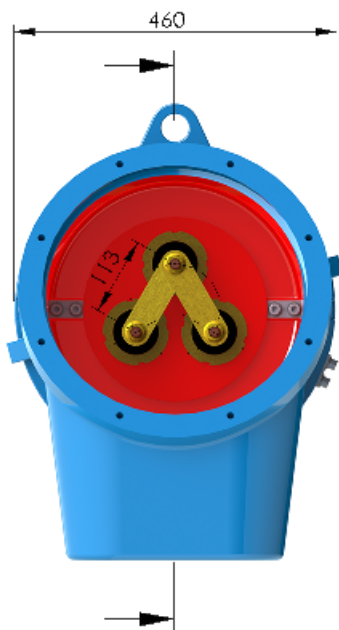

Flameproof Neutral Point Terminal Box - Groups I, II and III
Terminal Box Model: WTBX L
High Voltage: 6600V < U_n ≤ 11000V

| Protection Level | |
|-----------------------------|--------------------|
| IP66 | |
| Grounding | |
| Quantity | 3 |
| Cross section cables (max.) | 185mm ² |
| Material | Stainless steel |

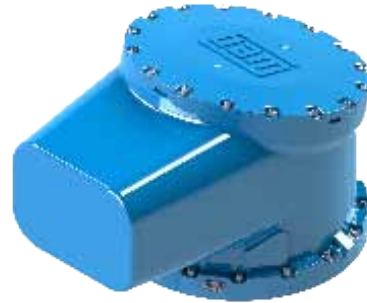

| Current Level | $I \leq 200A$ | $200A < I \leq 400A$ |
|--------------------|---------------|----------------------|
| Bushing / Terminal | 3 x M16 | |
| | | |

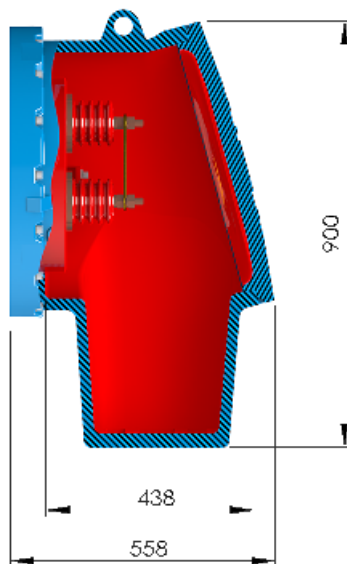
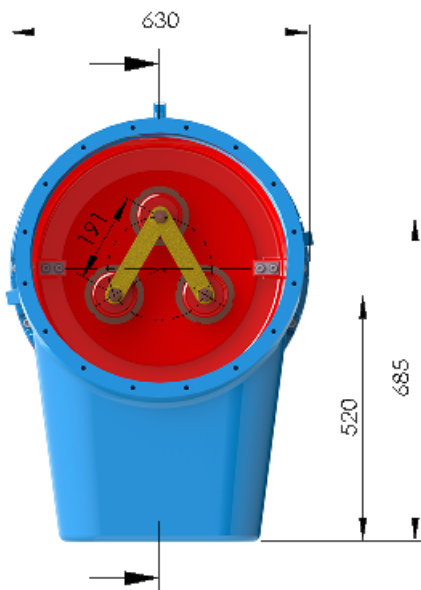

7.2.2. Current Transformers

Flameproof Current Transformer (Differential Protection) - Groups I, II and III
Auxiliary Terminal Box Model: CEFGH 500
Voltage: $U_n \leq 11000V$

| Protection Level | |
|-----------------------------|--------------------|
| IP66 | |
| Grounding | |
| Quantity | 1 |
| Cross section cables (max.) | 185mm ² |
| Material | Stainless steel |
| Technical Data | |
| Ratio | 50/5 |
| Burden (VA) | 5 |
| Class | 5P10 |

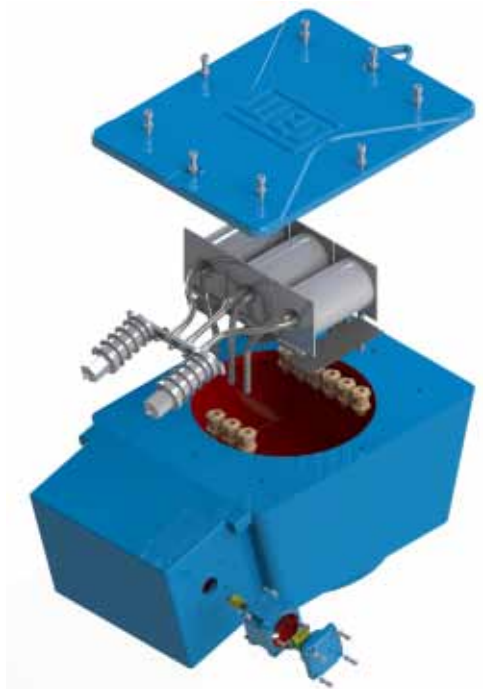
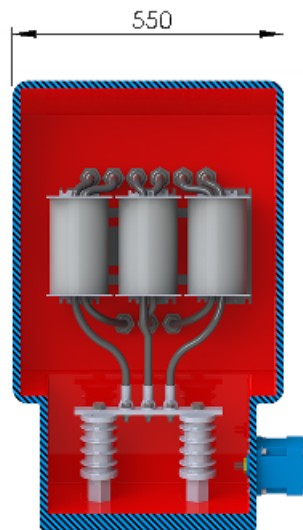
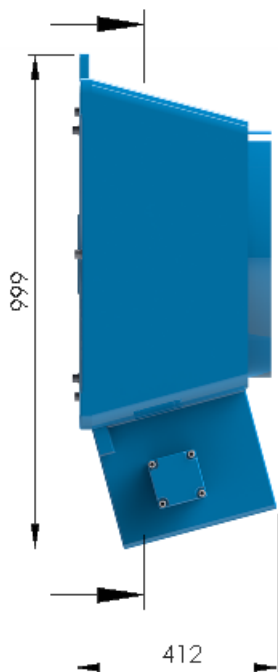
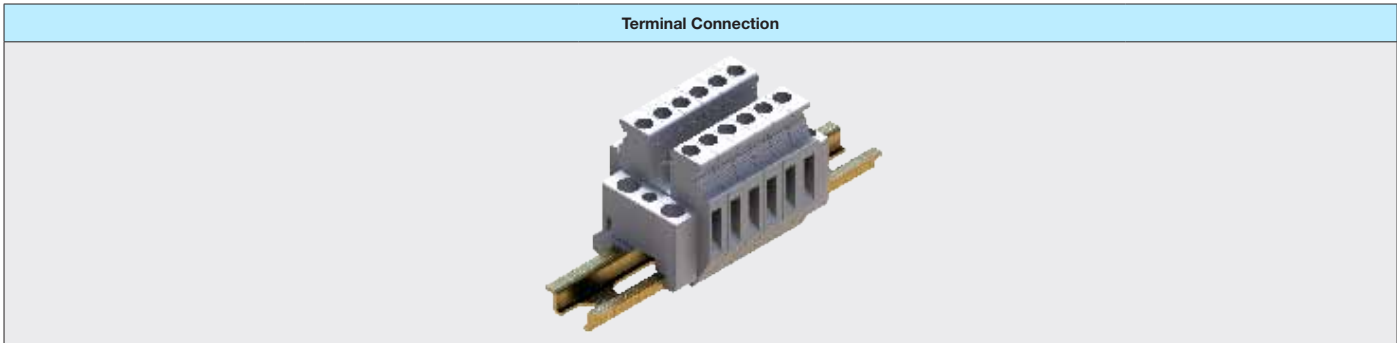
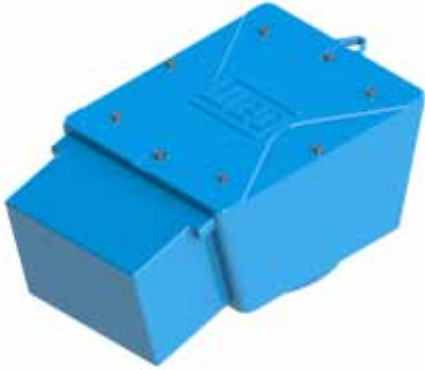

Flameproof Current Transformer (Measurement) - Groups I, II and III
Auxiliary Terminal Box Model: CEFGH 500
Voltage: $U_n \leq 11000V$

| Protection Level | |
|-----------------------------|--------------------|
| IP66 | |
| Grounding | |
| Quantity | 1 |
| Cross section cables (max.) | 185mm ² |
| Material | Stainless steel |
| Technical Data | |
| Ratio | 170/1 |
| Burden (VA) | 5 |
| Class | 1 |



Terminal Connection

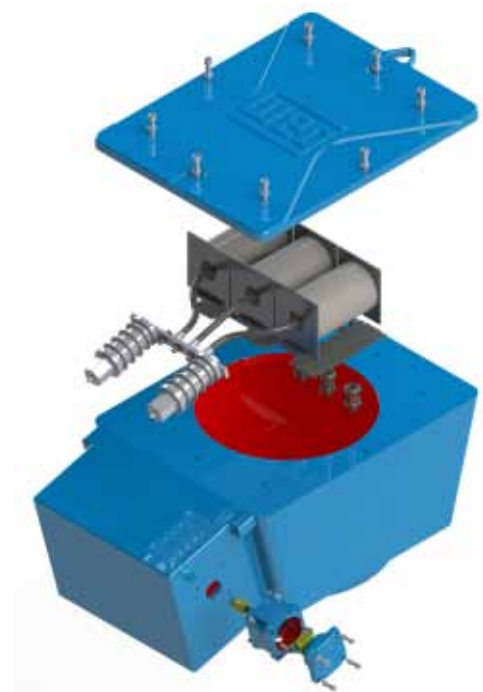
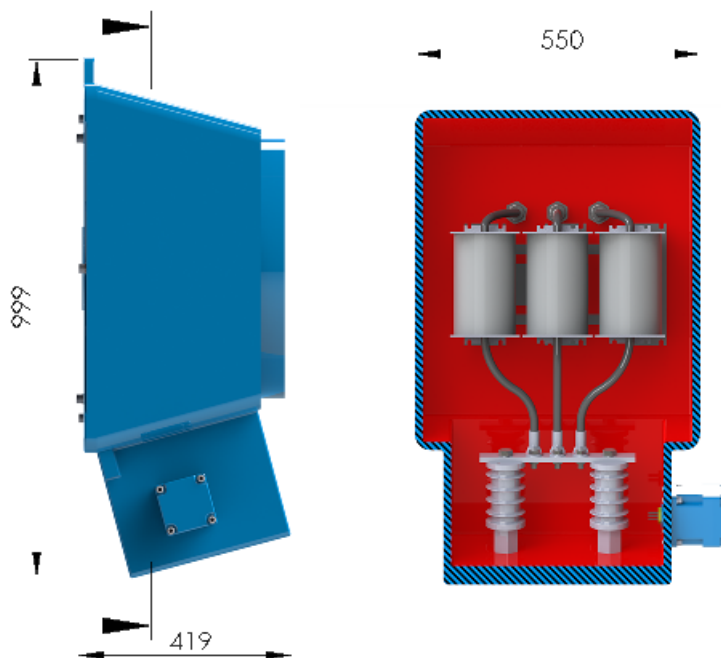

7.2.3. Partial Discharge Monitoring

Flameproof Partial Discharge Monitoring Terminal Boxes - Groups I, II and III
Auxiliary Terminal Box Models: CEFGH 500 and WTBX S
Voltage: $U_n \leq 11000V$

| Protection Level | |
|------------------|--|
| IP66 | |

| Technical Data | |
|----------------|-----------------|
| Voltage | 6.9kV / 16kV |
| Sensitivity | 1pC |
| Bandwith | 40MHz to 350MHz |

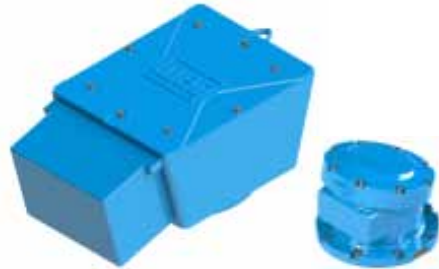

Terminal Connection

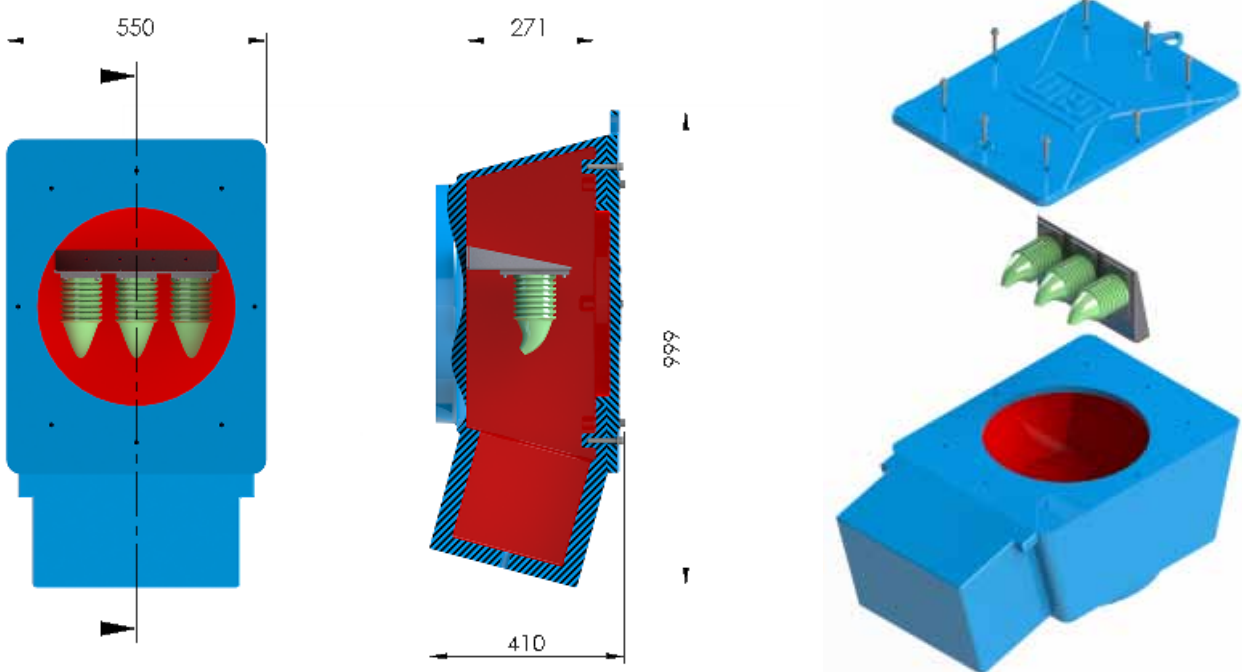
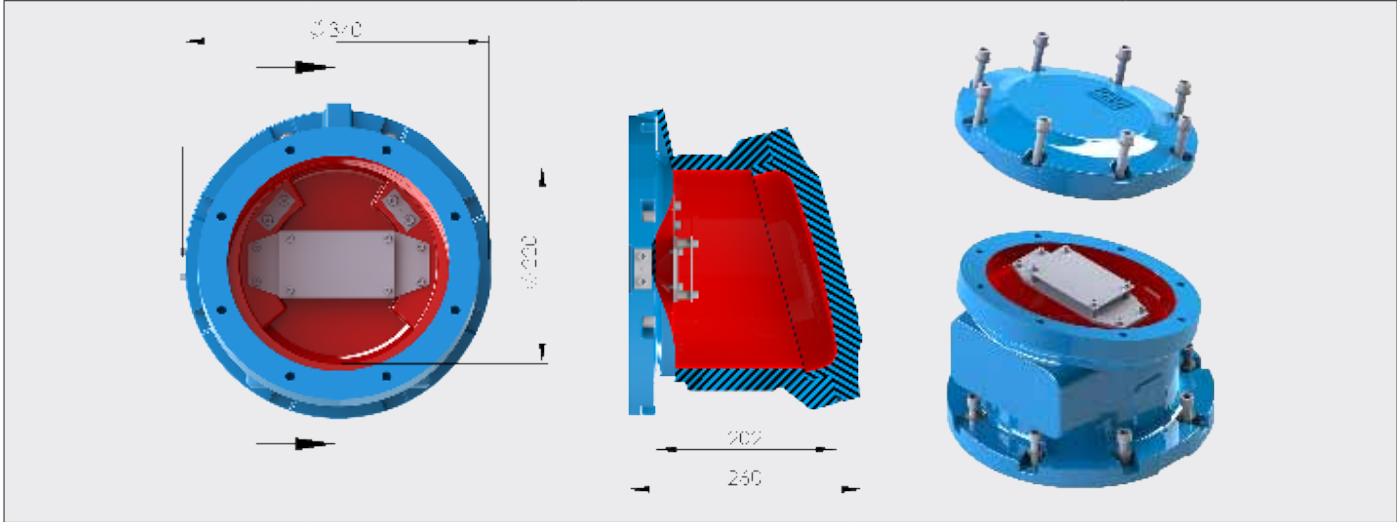

7

7.2.4. Surge Protection

Flameproof Surge Arrestors Terminal Box - Groups I, II and III
Auxiliary Terminal Box Model: CEFGH 500
Voltage: $U_n \leq 11000V$

| Protection Level | |
|-----------------------------|--------------------|
| IP66 | |
| Grounding | |
| Quantity | 1 |
| Cross section cables (max.) | 185mm ² |
| Material | Stainless steel |
| Technical Data | |
| Voltage | 3kV / 6kV / 9kV |



Surge Arrestor

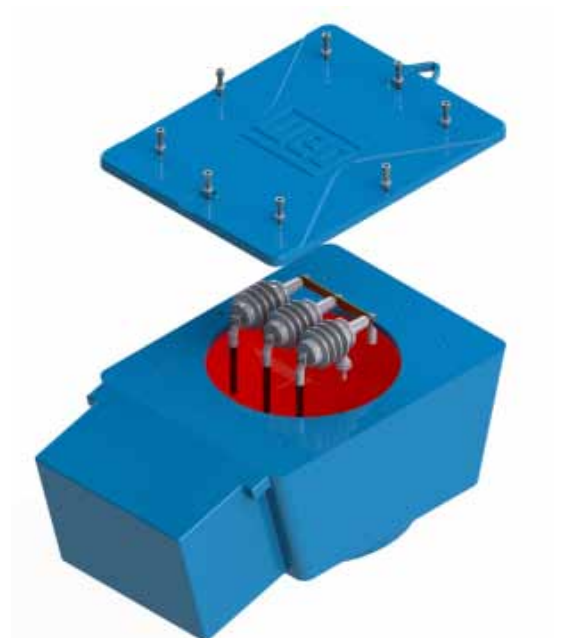
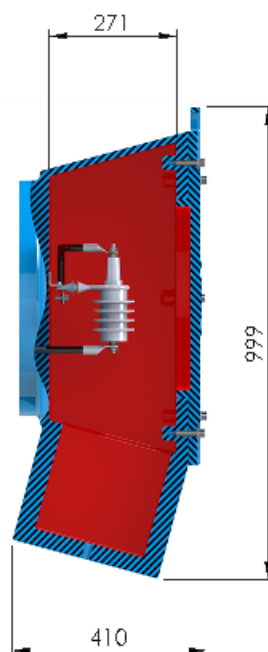
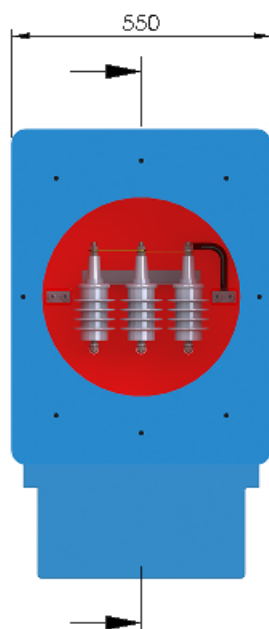

Flameproof Surge Capacitors Terminal Box - Groups I, II and III
Auxiliary Terminal Box Model: CEFGH 500
Voltage: $U_n \leq 6600V$

| Protection Level | |
|-----------------------------|--------------------|
| IP66 | |
| Grounding | |
| Quantity | 1 |
| Cross section cables (max.) | 185mm ² |
| Material | Stainless steel |
| Technical Data | |
| Voltage | 3,3kV / 6,6kV |
| Frequency | 50Hz / 60Hz |

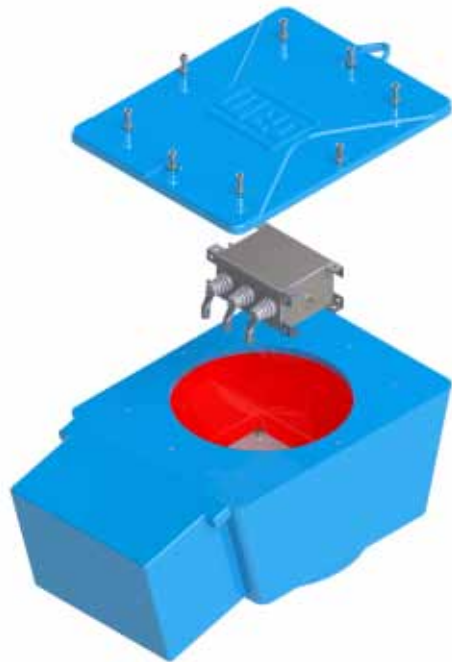
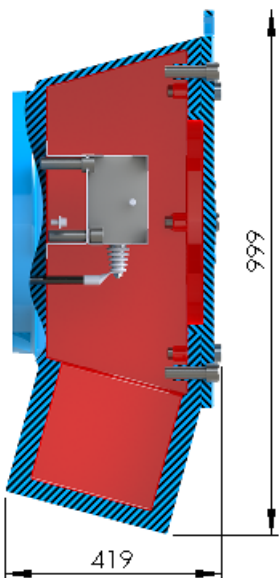
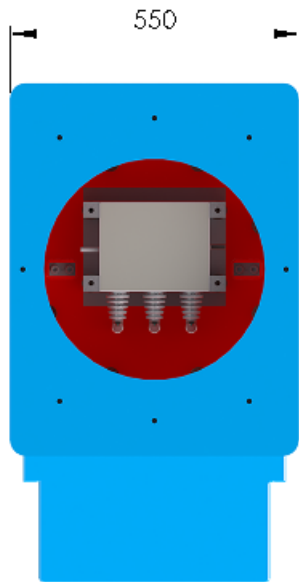
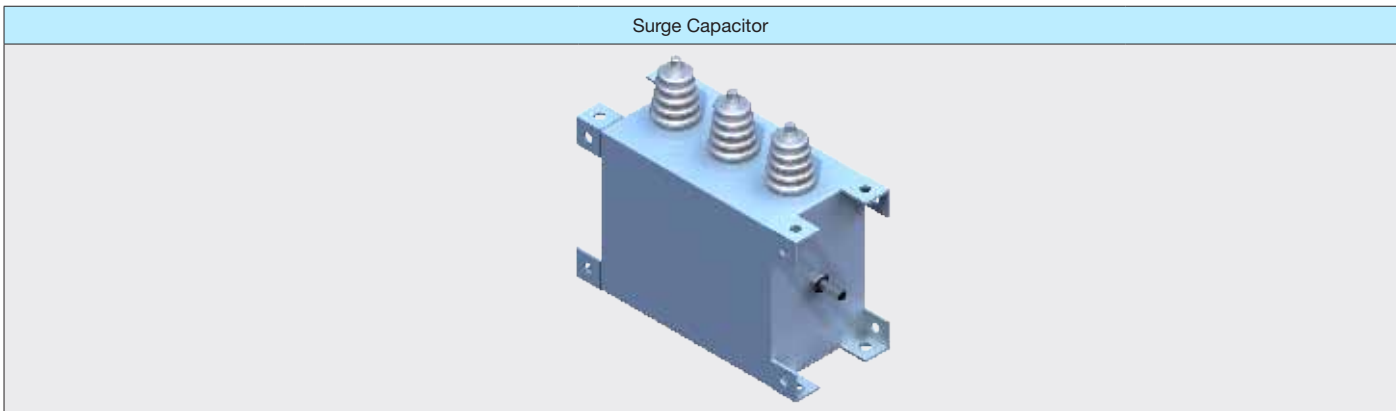
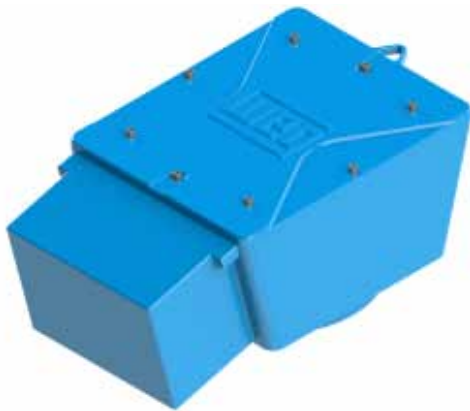

7

7.2.5. Protection Devices Connection

Space Heaters Terminal Box (Flameproof or Increased Safety) - Groups I, II and III Auxiliary Terminal Box Model: CG 47

| Protection Level | |
|--------------------------------|--|
| IP66 | |
| Grounding | |
| Quantity | 3 |
| Cross section cables (max.) | 185mm ² |
| Material | Stainless steel |
| Technical data | |
| Voltage (max.) | 500V |
| Current (max.) | 24A |
| Cross section of cables (max.) | 4mm ² (solid) / 2,5mm ² (stranded) |
| Number of connectors (max.) | 9 |

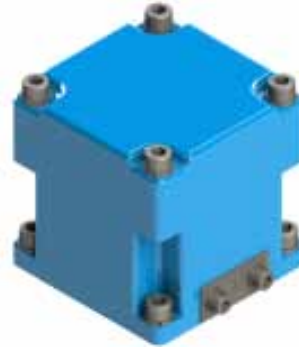

Terminal connection

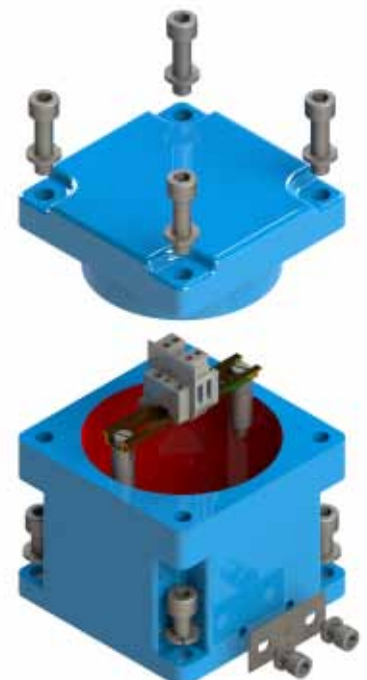
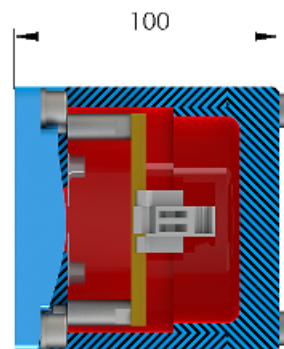
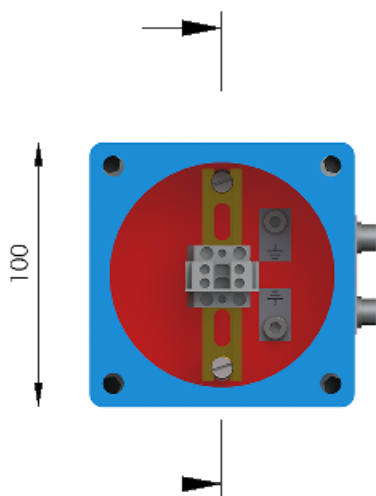
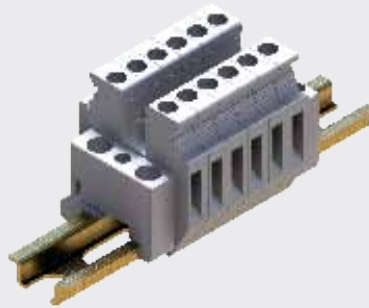

Thermal Protections Terminal Box (Flameproof or Increased Safety) - Groups I, II and III
Auxiliary Terminal Box Model: WTBX XS

| Protection Level | |
|--------------------------------|--|
| IP66 | |
| Grounding | |
| Quantity | 2 |
| Cross section cables (max.) | 185mm ² |
| Material | Stainless steel |
| Technical data | |
| Voltage (max.) | 500V |
| Current (max.) | 24A |
| Cross section of cables (max.) | 4mm ² (solid) / 2,5mm ² (stranded) |
| Number of connectors (max.) | 30 |



Terminal connection

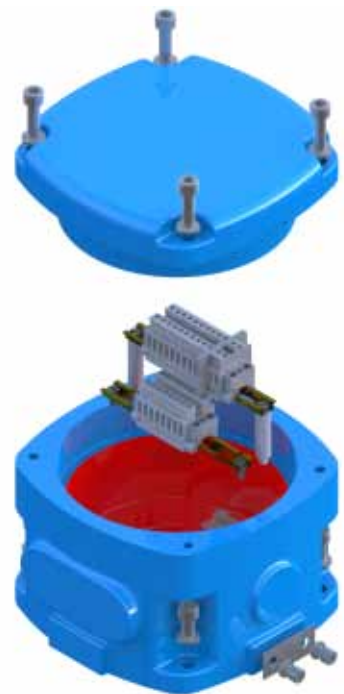
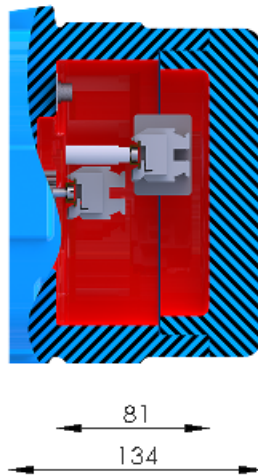
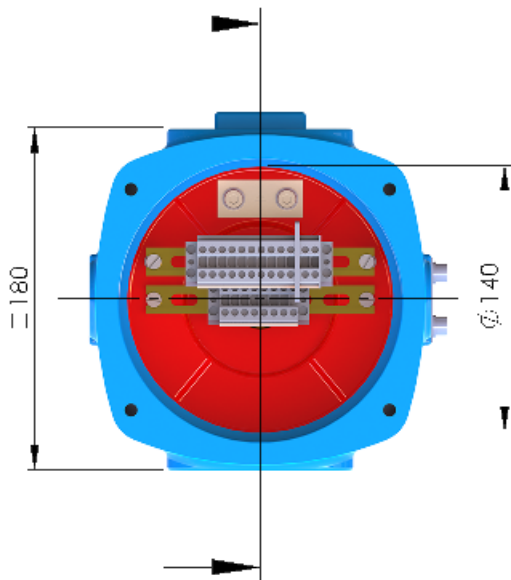
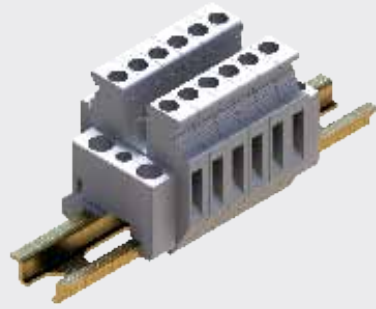

7

Thermal Protections Terminal Box (Flameproof or Increased Safety) - Groups I, II and III
Auxiliary Terminal Box Model: WTBX S

| Protection Level | |
|--------------------------------|--|
| IP66 | |
| Grounding | |
| Quantity | 3 |
| Cross section cables (max.) | 185mm ² |
| Material | Stainless steel |
| Technical data | |
| Voltage (max.) | 500V |
| Current (max.) | 24A |
| Cross section of cables (max.) | 4mm ² (solid) / 2,5mm ² (stranded) |
| Number of connectors (max.) | 62 |



Terminal connection

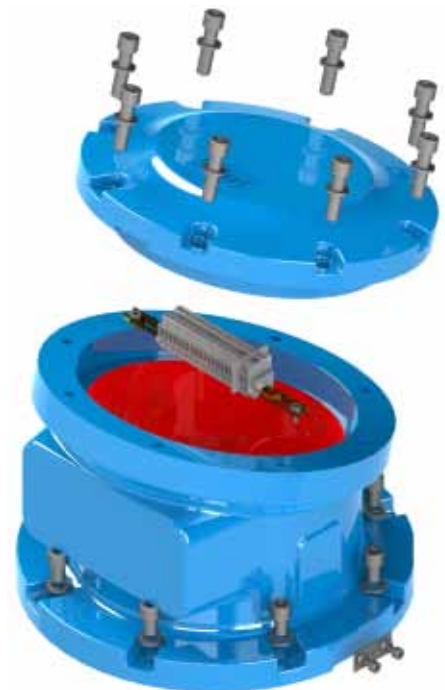
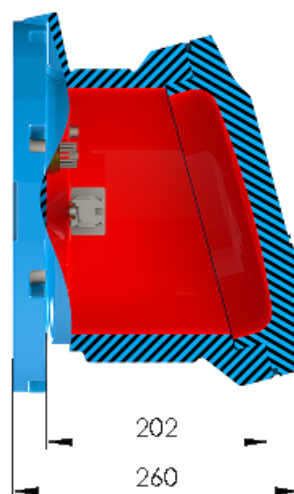
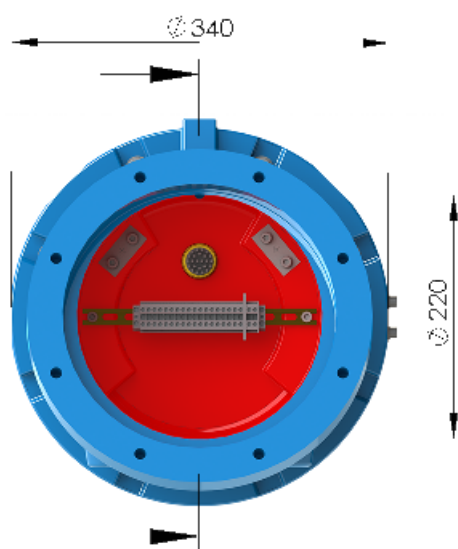
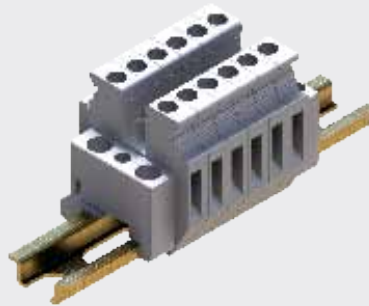

Optional Thermal Protection Terminal Box (Flameproof) - Groups I, II and III
Auxiliary Terminal Box Model: WTBX M

| Protection Level | |
|------------------|--|
| IP66 | |

| Grounding | |
|-----------------------------|--------------------|
| Quantity | 3 |
| Cross section cables (max.) | 185mm ² |
| Material | Stainless steel |

| Transmitters - Technical data | |
|---------------------------------|-------------------------------|
| Cross section of cables (max.) | 2,5mm ² (stranded) |
| Digital temperature transmitter | 4 - 20mA |

| Surge Arrestors - Technical data | |
|------------------------------------|--|
| Voltage (max.) | 24V |
| Nominal current | 500mA |
| Cross section of cables (max.) | 4mm ² (solid) / 2,5mm ² (stranded) |
| Total surge current (8/20) μ s | 24A |

| Maximum number of devices for thermal probes |
|--|
| 16 transmitters + 16 surge arrestors |

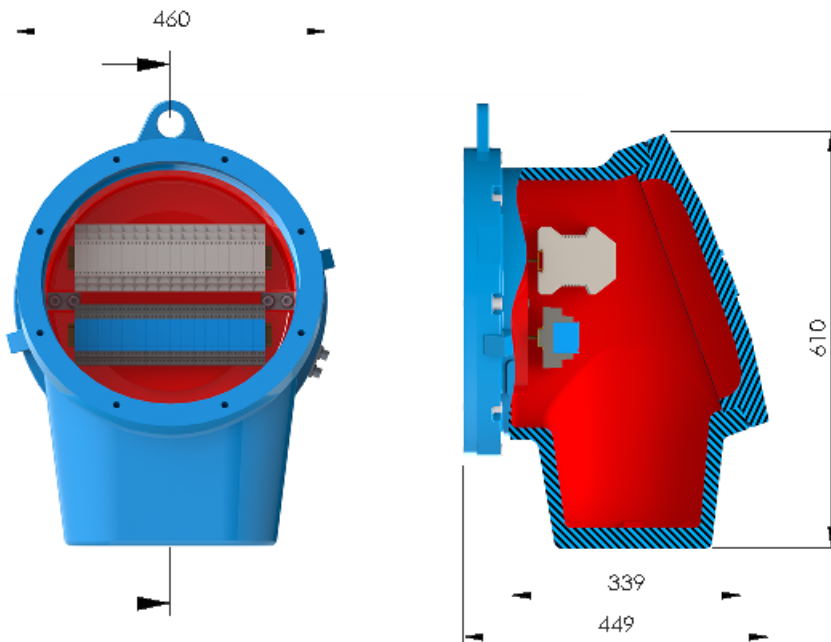

Additional Information

| | |
|--|------------|
| 8.1. Spare Parts | 171 |
| 8.2. Packaging | 171 |
| 8.3. Complete Outbound Logistics Services | 172 |
| 8.4. Environmental Commitment | 173 |
| 8.5. Inquiry / Order Check List | 174 |
| 8.6. International System of Units (SI) | 176 |

8. Additional Information

8.1. Spare Parts

For the first two years it is not necessary to acquire spare parts for motors with a continuous duty under normal operation conditions. If requested, spare parts can be supplied and for this it is necessary to inform WEG the motor serial number. In the table below the most common spare parts are listed.

| Spare Parts |
|---|
| Bearings |
| Axial or radial seal |
| Fan |
| Protections for winding and/or bearings |
| Grease nipple |
| Connectors (Auxiliary terminals) |
| Gasket |

Table 8.01 – Spare parts list

Notes:

- Constitution of spare parts stock should be decided by the customer, based upon the importance of the application.
- According to IEC 60079-19 Standard, maintenance and repair works must be carried out only by certified personnel.

8.2. Packaging

W22Xd motors are transported in wooden packages, all are fumigated (heat treatment) by a phytosanitary registered company, according to ISPM 15 Standard and Decree n° 95/2011 rules. A fumigation certificate can be provided if required. Horizontal and Vertical motors are packed in horizontal position. All motors fitted with roller bearings, angular contact bearings or sleeve bearings are supplied with shaft locking device. For the cases where the motor have to be transported in a vertical position a specific packing construction will be provided accordingly.

8.2.1. Wooden Standard Crate

Mainly used for road transport in Europe inland by truck, designed for handling by forklift or crane.

Standard dimensions, weights and volumes are described in the table 8.02.

| | | External height [m] | External width [m] | External length [m] | Weight [kg] | Volume [m ³] |
|--------------------------|--------|---------------------|--------------------|---------------------|-------------|--------------------------|
| W22Xd rib-cooled motors | 315L | 1,59 | 1,14 | 1,94 | 75 | 3,5 |
| | 355M/L | 1,70 | 1,27 | 2,06 | 81 | 4,4 |
| | 355A/B | 1,70 | 1,27 | 2,27 | 84 | 4,9 |
| | 400L/J | 1,84 | 1,15 | 2,52 | 163 | 5,3 |
| | 400G | 1,84 | 1,15 | 2,76 | 170 | 5,8 |
| | 450K/H | 1,94 | 1,35 | 2,80 | 188 | 7,3 |
| | 500K/H | 2,01 | 1,49 | 3,36 | 215 | 10,1 |
| W22Xd tube-cooled motors | 560H/G | 2,15 | 1,67 | 3,36 | 261 | 12,1 |
| | 560H/G | 1,95 | 1,79 | 3,55 | 267 | 12,4 |
| | 630J/H | 2,10 | 1,95 | 3,55 | 312 | 14,5 |
| | 710H/G | 2,28 | 2,15 | 4,18 | 441 | 20,5 |

Table 8.02 – W22Xd motor packing dimensions



Figure 8.01 – Wooden standard crate

8.2.2. Wooden Seaworthy Package

To suit the sea freight transport worldwide requests, the motors are duly protected against moisture & humidity inside of packing by aluminium foil and desiccant (silica gel) thermally closed in vacuum, see figure 8.03.



Figure 8.02 – Wooden seaworthy case - motor protection



Figure 8.03 – Stuffing with lashing on the case

The packages are manufactured with enough stiffness for lashing on the case (figure 8.04) or direct to motor eyebolts (figure 8.05):



Figure 8.04 – Stuffing with lashing direct to motor eyebolts

The design and construction of seaworthy packages takes in consideration the motor dimension vs. transport means/ limitations, optimized transport costs and logistics, as well as offloading conditions on the final customer's destination.

8.2.3. Wooden Airworthy Package

Adapted to comply with air freight companies logistic requirements with totally closed wooden case and smooth edges.

8.2.4. Special Designed Packaging

To meet special customers' specifications, destination conditions and long term storage special designs can be provided under request.



Figure 8.05 – Special designed packing ex. 1



Figure 8.06 – Special designed packing 2



Figure 8.07 – Special designed packing 3

Special marks can also be included on the packaging according to particular customer requirements.

8.3. Complete Outbound Logistics Services

WEG provides full delivery/transport service with any type of packaging, Customs procedures on departure/arrival points, including the insurance for all means of transport to the final destination and door-to-door delivery worldwide.



Figure 8.08 – Outbound logistics ex. 1



Figure 8.09 – Outbound logistics ex. 2

8.4. Environmental Commitment

WEG is conscientious and committed to a sustainable environmental growing. In our technical and economical development, we are always aware and concerned with the impacts of our activities on the preservation of the environment.

Our commitment leads us to a recognized environmental certification.

Supplier practices

In WEG suppliers approval process, the environmental practices are evaluated, as well as the environment impact on their raw materials and manufacturing processes.

Internal practices

From the design to its delivery, WEG uses adequate selection of raw materials, production processes, technology, means, resources and practices to prevent or reduce adverse consequences to the environment, ensuring the sustainability of our products throughout their life cycles.

Being aware of this responsibility, WEG goes beyond the pure compliance to the applicable laws.

Energy consumption is also one of WEG top priorities. Our motors are designed and manufactured to reach the highest efficiency levels.

Around 90% of the waste produced during manufacturing process is recycled, contributing to the preservation of our natural resources.

At WEG, we provide solutions designed to reduce carbon footprint, by becoming more energy-efficient.

Customer guidelines

WEG packages are designed to minimize the environment impact. The materials used in our packages (wood, plastic and nails), should be collected and recycled by our customers.

The plastic materials used in our packages are virgin polymers, providing the capability of making new products. Wood can also be transformed in chipboard, widely used in several applications, by a simple process.

During the motors life time, the used lubrication oil or grease should not be rejected to the soil or treated as a normal waste. These wastes must be sent to skilled operators to have proper treatment. Nevertheless this represents a very small quantity that can't be avoided.

In the end of a WEG motor life time, 98% of its components can be recovered by proper recycling processes.



8.5. Inquiry / Order Check List

This check list refers the essential information to be transmitted with inquiry/order. The maximum details provided will help both WEG/CUSTOMER to select/supply the correct motor to the application.

8.5.1. Basic Motor Data And Features

Motor Standards:

Basic Design:

- Rating: [kW]
- Frequency: [Hz]
- Poles/Speed:
- Insulation class: (F) / (H)
- Motor temp. rise: [K]
- Mounting form IM:
- Balancing grade: (A/B)
- Rotation view from D.E. side: CW CCW Both

Supply terminal box arrangement:

- 2nd power term. box:
 - Neutral point
 - Protection current transformer
 - Measuring current transformer
 - Surge arrestor
 - Surge suppressor
 - Other
- Terminal box adapter

Auxiliaries & Accessories:

- Protection on windings (if different from standard):
 - Thermistor: (PTC / NTC)
 - Pt100: - N° per phase:
- N° wires:
 - Auxiliary terminal box:
- Protection on bearings (if different from standard):
 - Thermistor: (PTC / NTC)
 - Pt100: - N° per bearing:
- N° wires:
 - Auxiliary terminal box:
 - Same terminal box of windings protections
 - 2nd auxiliary terminal box
 - 2 separate terminal boxes (1/endshield)
- Space heaters (if different from standard):
 - Voltage: [V]
 - Individual terminal box:

Cable Entry Details: **RHS** **LHS**

- Cable entry direction view from D.E. side:
- N° of cable entries:
 - Supply terminal box:
 - Auxiliary terminal box(es):
 - Glands thread size(s):
- Supply/Instrumentation cable information:
 - N° cables:
 - Type of cables: (armoured / non armoured)
 - Cables diameter: - External:
 - Without armour:
- Cable gland supplied with motor: (WEG can supply glands acc. to info about cables):
 - Cable gland(s) size(s):
 - Cable gland(s) type(s):

8.5.2. Site & Working Conditions

Starting:

- Starting method:
 - DOL:
 - VSD: Speed range: Min./Max. torque:
 - Soft starter:
 - Star / Delta:
 - Other:
- Duty (S1):
- Service factor (1,0):
- N° starts/hour: Cold:
 Hot:

Coupling:

- Direct
- Pulley/Belt (in this case, complete form in the next page)
- Gearbox.:
 - Gearbox ratio:

Ambient Conditions:

- Ambient temperature: (°C)
- Min. temperature: (°C)
- Max. temperature: (°C)
- Humidity: (%)
- Altitude: (m.a.s.l.)
- Environment: (Saline; Alcaline; Marine; Petrochemical; Sulphur (H2S); Other...)

Paint Scheme (if different from standard):

- 202E
- 202P
- 211E
- 211P
- 212E
- 212P
- 213E
- Color (RAL):

Driven Machine Data:

- Driven machine type: (centrifugal fan/pump; reciprocating pump/compressor; blower; mills; cranes; conveyor belt; ...)
- Absorbed power: [kW]
- Driven machine torque curve: (Quadratic; constant; other...)
- Starting torque: [Nm]
- Rated torque: [Nm]
- Load inertia: (J or PD²)

Pulley/Belt Power Transmission

Customer
Motor

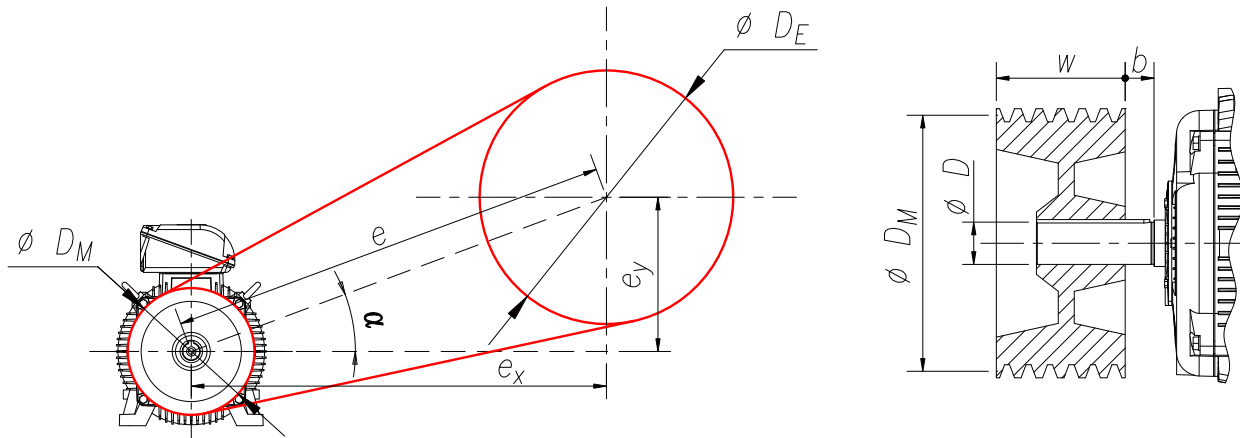

| | | |
|--|----------------|------------------------------|
| Driven machine type | | |
| Motor's nominal output | | [kW] |
| Motor's nominal speed | | [rpm] |
| ⁽¹⁾ Motor's pulley diameter (ϕD_M) | | [mm] |
| ⁽¹⁾ Driven machine's pulley diameter (ϕD_E) | | [mm] |
| ⁽²⁾ Driven machine's nominal speed | | [rpm] |
| ⁽²⁾ x-component of the distance between pulleys center (e_x) | | [mm] |
| ⁽²⁾ y-component of the distance between pulleys center (e_y) | | [mm] |
| ⁽²⁾ Distance between pulleys' center (e) | | [mm] |
| ⁽²⁾ Angle between pulleys alignment and horizontal plane (α) | | [°] |
| Belt type | | ex.: Plain, SPZ, SPB, SPC... |
| Number of belts | | |
| Motor's pulley total width (w) + dist. to the shaft shoulder (b) | $w =$ $b =$ | [mm] |
| Weight of motor pulley | | [kg] |
| ⁽³⁾ End shaft diameter (D) | | [mm] |

⁽¹⁾ Fill in at least one.

⁽²⁾ Fill in at least two.

⁽³⁾ Fill in for special cases.

8.6. International System of Units (SI)

| Measure | Measure Symbol | Unit | Symbol | Definition |
|-------------------------------|------------------------|----------|----------|--|
| (*) Length | l | meter | m | - |
| (*) Mass | m | kilogram | kg | - |
| (*) Time | t | second | s | - |
| (*) Electric Current | I | ampere | A | - |
| (*) Thermodynamic Temperature | T | kelvin | K | $1^{\circ}\text{K} = 1^{\circ}\text{C} + 273.15$ |
| Plane Angle | α, β, \dots | radian | rad | $1^{\circ} = \pi / 180 \text{ rad}$ |
| Frequency | f | hertz | Hz | $1\text{Hz} = 1/\text{s}$ |
| Force | F | newton | N | $1\text{N} = 1\text{Kg.m/s}^2$ |
| Pressure | p | pascal | Pa | $1\text{Pa} = 1\text{N/m}^2$ |
| Energy | E | | | |
| Work | W | joule | J | $1\text{J} = 1\text{N.m} = 1\text{W.s}$ |
| Quantity of Heat | Q | | | |
| Power | P | watt | W | $1\text{W} = 1\text{J} / \text{s}$ |
| Electric Charge | Q | coulomb | C | $1\text{C} = 1\text{J/s} = 1\text{A.s}$ |
| Electric Potential | V | | | |
| Electromotive Force | E | volt | V | $1\text{V} = 1\text{J/C} = 1\text{W/A}$ |
| Potential Difference | U | | | |
| Electric Capacitance | C | farad | F | $1\text{F} = 1\text{C} / \text{V}$ |
| Electric Resistance | R | ohm | Ω | $1\Omega = 1\text{V} / \text{A}$ |
| Electric Conductance | G | siemens | S | $1\text{S} = 1 / \Omega$ |
| Magnetic Flux | Φ | weber | Wb | $1\text{Wb} = 1\text{V} \cdot \text{s}$ |
| Magnetic Flux Density | B | tesla | T | $1\text{T} = 1\text{Wb} / \text{m}^2$ |

| Measure | Measure Symbol | Unit | Symbol | Definition |
|------------------------|----------------|---------|--------------------|---------------------------------|
| Inductance | L | henry | H | $1H = 1Wb / A$ |
| Power Factor | Cos φ | - | - | (W/VA) |
| Magnetic Field | H | - | A / m | - |
| Inertia | J | - | kg. m ² | $1J = \Sigma m.r^2 = G.D^2 / 4$ |
| Sound Power | Lw | decibel | dB | - |
| Sound Pressure | Lp | decibel | dB | - |
| Area | A | - | m ² | - |
| Volume | V | - | m ³ | - |
| Force Moment (Torque) | M | - | N . m | $M = F . r$ |
| Angular Speed | ω | - | rad / s | - |
| Linear Speed | v | - | m / s | - |
| Speed of Rotation | N | - | s ⁻¹ | - |
| (*) Luminous Intensity | Iv | candela | cd | lm/sr(**) |
| Luminous Flux | F | lumen | lm | cd.sr |
| Illuminance | Ev | lux | lx | $1lx = 1 cd / m^2$ |

(*) Base Units

(**) sr-steradian

Metric Prefixes & Symbols

To designate multiples and submultiples

| Factor | Prefix | Symbol |
|------------------|--------|--------|
| 10 ²⁴ | iota | Y |
| 10 ²¹ | zeta | Z |
| 10 ¹⁸ | exa | E |
| 10 ¹⁵ | peta | P |
| 10 ¹² | tera | T |
| 10 ⁹ | giga | G |
| 10 ⁶ | mega | M |
| 10 ³ | quilo | k |
| 10 ² | hecto | h |
| 10 ¹ | deca | da |

| Factor | Prefix | Symbol |
|-------------------|--------|--------|
| 10 ⁻¹ | deci | d |
| 10 ⁻² | centi | c |
| 10 ⁻³ | mili | m |
| 10 ⁻⁶ | micro | μ |
| 10 ⁻⁹ | nano | n |
| 10 ⁻¹² | pico | p |
| 10 ⁻¹⁵ | fento | f |
| 10 ⁻¹⁸ | ato | a |
| 10 ⁻²¹ | zepto | z |
| 10 ⁻²⁴ | iocto | y |

Useful Formulae

| Measure | Formula | Unit | |
|----------------------------|---|--|------------------|
| Output Power | $P_{ut} = \frac{B_{mot} \times N}{9.55 \times 1000} = \frac{\sqrt{3} \times U \times I \times \cos \varphi \times \eta}{1000 \times 100}$ | kW | |
| Absorbed Power | $P_{abs} = \frac{P_{ut} \times 100}{\eta} = \frac{\sqrt{3} \times U \times I \times \cos \varphi}{1000}$ | kW | |
| Reactive Power | $Q = \frac{P_{ut} \times \tan \varphi \times 100}{\eta} = P_{abs} \times \tan \varphi = \frac{\sqrt{3} \times U \times I \times \sin \varphi}{1000}$ | kVAr | |
| Apparent Power | $S = \frac{P_{ut} \times 100}{\eta \times \cos \varphi} = \frac{\sqrt{3} \times U \times I}{1000}$ | kVA | |
| Nominal Current | $I = \frac{P_{abs} \times 1000}{\sqrt{3} \times U \times \cos \varphi} = \frac{P_{ut} \times 1000 \times 100}{\sqrt{3} \times U \times \cos \varphi \times \eta}$ | A | |
| Power Factor | $\cos \varphi = \frac{P_{abs} \times 1000}{\sqrt{3} \times U \times I} = \frac{P_{ut} \times 1000 \times 100}{\sqrt{3} \times U \times I \times \eta}$ | - | |
| Slip | $g = \frac{N_s - N}{N_s} \times 100$ | % | |
| Efficiency | $\eta = \frac{P_{ut} \times 100}{P_{abs}}$ | % | |
| Synchronous Speed | $N_s = \frac{60 \times f}{p}$ | rpm | |
| Force | $F = m \times a$ | N | |
| Moment | $M = F \times r$ | N.m | |
| Power | a) rotation | $P = M \times \omega$ | W |
| | b) linear | $P = F \times V$ | |
| Moment of Inertia | a) gravity centre | $J = m \times r^2$ | kgm ² |
| | b) solid cylinder | $J = m \times \frac{r^2}{2}$ | |
| | c) hollow cylinder | $J = m \times \frac{r_1^2 + r_2^2}{2}$ | |
| Inertia in Linear Movement | $J = m \times \left(\frac{V}{\omega}\right)^2$ | kgm ² | |

Symbols used in formulas

| Symbol | Unit | Meaning | Symbol | Unit | Meaning |
|----------------|------|--------------------------------|----------|-------------------|-------------------|
| P_{ut} | kW | Output power at motor shaft | f | Hz | Frequency |
| P_{abs} | kW | Absorbed power from supply net | p | - | Pole pairs |
| S | kVA | Apparent power | F | N | Force |
| Q | kVAr | Reactive power | m | Kg | Mass |
| I | A | Phase current | a | m / s^2 | Acceleration |
| $\cos \varphi$ | - | Power factor | M | N.m | Moment |
| η | % | Efficiency | ω | rad / s | Angular speed |
| N_s | rpm | Synchronous speed | P | W | Power |
| N | rpm | Nominal speed | V | m / s | Linear speed |
| g | % | Slip | J | Kg.m ² | Moment of inertia |
| B_{mot} | N.m | Motor torque | rZ | m | Radius |

Typical Motor Curve with Load Quadratic Torque

| Measure | Symbol | Unit | Measure | Symbol | Unit |
|--------------------------------|--------|--------------------------|------------------|-----------|------|
| Starting current | I_a | | Starting torque | B_a | |
| Full load current | I_n | A | Pull up torque | B_{min} | |
| No load current | I_o | | Breakdown torque | B_{max} | N.m |
| Synchronous speed | N_s | | Rated torque | B_n | |
| Assynchronous or nominal speed | N | rpm ou min ⁻¹ | | | |

Motor Torque / Current vs Speed Curves

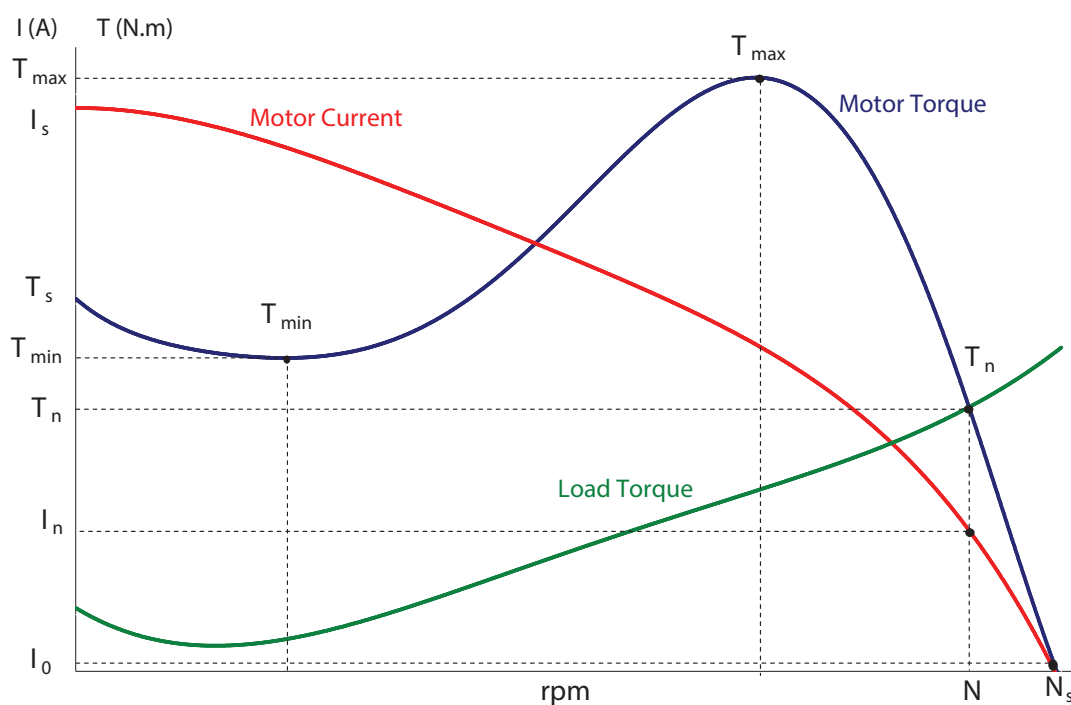



Support & Servicing

Your Business is our Success!

In addition to our solutions we provide a **pre-sale support** with technical know-how, helping you on the proper selection for your application, as well as a wide variety of **aftermarket services** that builds long-term customer success through:

- Manufacturer Support to all WEG Products
- Factory Repairs and Refurbishments
- Parts - Spare and Replacement
- Certified Workshops Worldwide
- Site Service Specialist Network
- Service Contracts
- Site Repairs and Troubleshooting
- Field Support Linked to Engineering
- Installation and Start-up Service
- Inspection and Maintenance
- Warranty Support

A large offshore oil rig is silhouetted against a bright orange sunset sky over the ocean. The sun is low on the horizon, creating a strong reflection on the water. The rig's complex structure of towers and cranes is visible against the glowing background.

When it comes to **HAZARDOUS AREAS,**

We make it SAFE!

WEG, a leading supplier of hazardous area solutions

Meet the other members of the W22X family

W22Xn

Non-Sparking motors (Ex nA/Ex tc machines)
Suitable for Zones 2 and 22 classified areas
From 0.12 to 450kW
Frames 63 to 355A/B
Voltages: up to 690V

W22Xtb

Dust Ignition Proof motors (Ex tb machines)
Suitable for Zone 21 classified areas
From 0.12 to 450kW
Frames 63 to 355A/B
Voltages: up to 690V

W22Xd Low Voltage

Flameproof motors (Ex d/Ex de/Ex tb machines)
Suitable for Zones 1 and 2 classified areas
From 0.12 to 1400kW
Frames 71 to 500
Voltages: up to 1100V

Other WEG industrial motors for hazardous areas

Non-Sparking, Increased Safety and Pressurized

Up to 50,000kW
Voltages: up to 13,800V

Other WEG industrial products

Gearboxes
Automation
Energy
Transmission & Distribution
Coatings

...

And industrial solutions...

Please visit us at www.weg.net to learn more about our products.

WEG Worldwide Operations

ARGENTINA

WEG EQUIPAMIENTOS
ELECTRICOS
San Francisco - Cordoba
Phone: +54 3564 421 484
info-ar@weg.net
www.weg.net/ar

WEG PINTURAS - Pulverlux
Buenos Aires
Phone: +54 11 4299 8000
tintas@weg.net

AUSTRALIA

WEG AUSTRALIA
Victoria
Phone: +61 3 9765 4600
info-au@weg.net
www.weg.net/au

AUSTRIA

WATT DRIVE - WEG Group
Markt Piesting - Vienna
Phone: +43 2633 404 0
watt@wattdrive.com
www.wattdrive.com

BELGIUM

WEG BENELUX
Nivelles - Belgium
Phone: +32 67 88 84 20
info-be@weg.net
www.weg.net/be

BRAZIL

WEG EQUIPAMENTOS ELÉTRICOS
Jaraguá do Sul - Santa Catarina
Phone: +55 47 3276-4002
info-br@weg.net
www.weg.net/br

CHILE

WEG CHILE
Santiago
Phone: +56 2 784 8900
info-cl@weg.net
www.weg.net/cl

CHINA

WEG NANTONG
Nantong - Jiangsu
Phone: +86 0513 8598 9333
info-cn@weg.net
www.weg.net/cn

COLOMBIA

WEG COLOMBIA
Bogotá
Phone: +57 1 416 0166
info-co@weg.net
www.weg.net/co

FRANCE

WEG FRANCE
Saint Quentin Fallavier - Lyon
Phone: +33 4 74 99 11 35
info-fr@weg.net
www.weg.net/fr

GERMANY

WEG GERMANY
Kerpen - North Rhine Westphalia
Phone: +49 2237 9291 0
info-de@weg.net
www.weg.net/de

GHANA

ZEST ELECTRIC GHANA
WEG Group
Accra
Phone: +233 30 27 664 90
info@zestghana.com.gh
www.zestghana.com.gh

INDIA

WEG ELECTRIC INDIA
Bangalore - Karnataka
Phone: +91 80 4128 2007
info-in@weg.net
www.weg.net/in

WEG INDUSTRIES INDIA

Hosur - Tamil Nadu
Phone: +91 4344 301 501
info-in@weg.net
www.weg.net/in

ITALY

WEG ITALIA
Cinisello Balsamo - Milano
Phone: +39 02 6129 3535
info-it@weg.net
www.weg.net/it

JAPAN

WEG ELECTRIC MOTORS
JAPAN
Yokohama City - Kanagawa
Phone: +81 45 550 3030
info-jp@weg.net
www.weg.net/jp

MALAYSIA

WATT EURO-DRIVE - WEG Group
Shah Alam, Selangor
Phone: 603 78591626
info@wattdrive.com.my
www.wattdrive.com

MEXICO

WEG MEXICO
Huehuetoca
Phone: +52 55 5321 4231
info-mx@weg.net
www.weg.net/mx

VOLTRAN - WEG Group

Tizayuca - Hidalgo
Phone: +52 77 5350 9354
www.voltran.com.mx

NETHERLANDS

WEG NETHERLANDS
Oldenzaal - Overijssel
Phone: +31 541 571 080
info-nl@weg.net
www.weg.net/nl

PERU

WEG PERU
Lima
Phone: +51 1 472 3204
info-pe@weg.net
www.weg.net/pe

PORTUGAL

WEG EURO
Maia - Porto
Phone: +351 22 9477705
info-pt@weg.net
www.weg.net/pt

RUSSIA and CIS

WEG ELECTRIC CIS
Saint Petersburg
Phone: +7 812 363 2172
info-ru@weg.net
www.weg.net/ru

SOUTH AFRICA

ZEST ELECTRIC MOTORS
WEG Group
Johannesburg
Phone: +27 11 723 6000
info@zest.co.za
www.zest.co.za

SPAIN

WEG IBERIA
Madrid
Phone: +34 91 655 30 08
info-es@weg.net
www.weg.net/es

SINGAPORE

WEG SINGAPORE
Singapore
Phone: +65 68589081
info-sg@weg.net
www.weg.net/sg

SCANDINAVIA

WEG SCANDINAVIA
Kungsbacka - Sweden
Phone: +46 300 73 400
info-se@weg.net
www.weg.net/se

UK

WEG ELECTRIC MOTORS U.K.
Redditch - Worcestershire
Phone: +44 1527 513 800
info-uk@weg.net
www.weg.net/uk

UNITED ARAB EMIRATES

WEG MIDDLE EAST
Dubai
Phone: +971 4 813 0800
info-ae@weg.net
www.weg.net/ae

USA

WEG ELECTRIC
Duluth - Georgia
Phone: +1 678 249 2000
info-us@weg.net
www.weg.net/us

ELECTRIC MACHINERY

WEG Group
Minneapolis - Minnesota
Phone: +1 612 378 8000
www.electricmachinery.com

VENEZUELA

WEG INDUSTRIAS VENEZUELA
Valencia - Carabobo
Phone: +58 241 821 0582
info-ve@weg.net
www.weg.net/ve

Please visit us at www.weg.net for more details about our local distribution network in your country.

Com o apoio de:



WEG Group - Motors Unit
Maia - Portugal
Phone: (+351) 229 477 700
info-pt@weg.net
www.weg.net/pt

