

# Micron TRUE Planetary<sup>®</sup> Gearheads

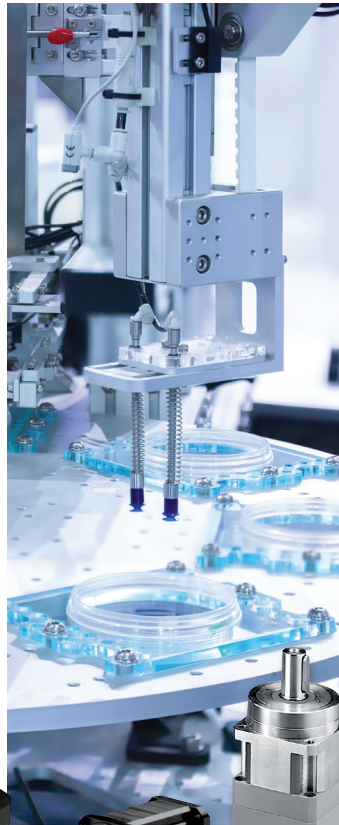
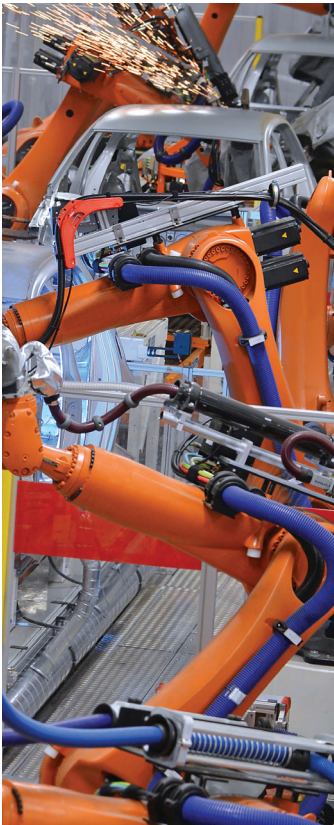

# Boston Gear

Boston Gear offers the industry's largest line up of reliable speed reducers, gearing and other quality drivetrain components.

With more than 125 years of frontline experience, Boston Gear is recognized globally as a premier resource for extremely reliable, high-performance power transmission components. Boston Gear offers the industry's most comprehensive product array featuring more than 30,000 standard products combined with the ability to custom engineer unique solutions when required. Product lines include standard enclosed gear drives, custom speed reducers, AC/DC motors, DC drives and Centric brand overload clutches and torque limiters.

VISIT US ON THE WEB AT  
**BOSTONGEAR.COM**



# Altra Motion

Altra is a leading global designer and producer of a wide range of electromechanical power transmission and motion control components and systems. Providing the essential control of equipment speed, torque, positioning, and other functions, Altra products can be used in nearly any machine, process or application involving motion. From engine braking systems for heavy duty trucks to precision motors embedded in medical robots to brakes used on offshore wind turbines, Altra has been serving customers around the world for decades.

Altra's leading brands include **Ameridrives**, **Bauer** Gear Motor, **Bibby** Turboflex, **Boston** Gear, **Delevan**, **Delroyd** Worm Gear, **Deltran**, **Formsprag** Clutch, **Guardian** Couplings, **Huco**, **Jacobs** Vehicle Systems, **Kilian**, **Kollmorgen**, **Lamiflex** Couplings, **Marland** Clutch, **Matrix**, **Nuttall** Gear, **Portescap**, **Stieber**, **Stromag**, **Svendborg** Brakes, **TB Wood's**, **Thomson**, **Twiflex**, **Warner** Electric, **Warner** Linear and **Wichita** Clutch.

VISIT US ON THE WEB AT **ALTRAMOTION.COM**



# Micron TRUE Planetary® Gearheads

## Index

Product Overview . . . . .	4
True Planetary Gearheads . . . . .	6
Helical Crowned True Planetary Gearheads . . . . .	7
PowerTRUE™ Right Angle Gearheads . . . . .	8
Gearhead Sizing and Selection . . . . .	9
Micron Quick Selection Guide . . . . .	10
Micron MOTIONEERING® . . . . .	12
RediMount™ Motor Mounting System . . . . .	14
<b>AquaTRUE™ Planetary Gearheads . . . . .</b>	<b>15</b>
AquaTRUE Introduction . . . . .	16
AquaTRUE Dimensions . . . . .	17
AquaTRUE Specifications . . . . .	17
Radial and Axial Load Ratings . . . . .	19
<b>XTRUE™ Planetary Gearheads . . . . .</b>	<b>20</b>
XTRUE Introduction . . . . .	21
XTRUE XT Dimensions/Specifications . . . . .	22
XTRUE XTA Dimensions/Specifications . . . . .	23
XTRUE Specifications . . . . .	24
Radial and Axial Load Ratings . . . . .	27
<b>NemaTRUE™ Planetary Gearheads . . . . .</b>	<b>28</b>
NemaTRUE Size 17 . . . . .	29
NemaTRUE Size 23/60 . . . . .	30
NemaTRUE Size 34/90 . . . . .	31
NemaTRUE Size 42/115 . . . . .	32
Radial and Axial Load Ratings . . . . .	33
<b>NemaTRUE 90 Right Angle Gearheads . . . . .</b>	<b>34</b>
NemaTRUE 90 Size 23 . . . . .	35
NemaTRUE 90 Size 34 . . . . .	36
NemaTRUE 90 Size 42 . . . . .	37
Radial and Axial Load Ratings . . . . .	38
<b>DuraTRUE™ Planetary Gearheads . . . . .</b>	<b>40</b>
DuraTRUE Size 60 . . . . .	41
DuraTRUE Size 90 . . . . .	42
DuraTRUE Size 115 . . . . .	43
DuraTRUE Size 142 . . . . .	44
Radial and Axial Load Ratings . . . . .	45
<b>DuraTRUE 90 Right Angle Gearheads . . . . .</b>	<b>46</b>
DuraTRUE 90 Size 60 . . . . .	47
DuraTRUE 90 Size 60S (Slim Line) . . . . .	48
DuraTRUE 90 Size 90 . . . . .	49
DuraTRUE 90 Size 90S (Slim Line) . . . . .	50
DuraTRUE 90 Size 115 . . . . .	51
DuraTRUE 90 Size 115S (Slim Line) . . . . .	52
DuraTRUE 90 Size 142 . . . . .	53
DuraTRUE 90 Size 142S (Slim Line) . . . . .	54
Radial and Axial Load Ratings . . . . .	55
<b>DuraTRUE 90 (Hollow Shaft) Right Angle Gearheads . . . . .</b>	<b>58</b>
DuraTRUE 90 Size 90H . . . . .	59
DuraTRUE 90 Size 115H . . . . .	60
DuraTRUE 90 Size 142H . . . . .	61
Radial and Axial Load Ratings . . . . .	62

<b>DuraTRUE 90 (Dual Shaft) Right Angle Gearheads . . . . .</b>	<b>64</b>
DuraTRUE 90 Size 60D . . . . .	65
DuraTRUE 90 Size 90D . . . . .	66
DuraTRUE 90 Size 115D . . . . .	67
DuraTRUE 90 Size 142D . . . . .	68
Radial and Axial Load Ratings . . . . .	69
<b>ValueTRUE™ Planetary Gearheads . . . . .</b>	<b>70</b>
ValueTRUE Inline Dimensions . . . . .	72
ValueTRUE Right Angle Dimensions . . . . .	73
Inline Specifications: VT006-VT010 . . . . .	74
Inline Specifications: VT115-VT022 . . . . .	75
Right Angle Specifications: VTR006-VTR075 . . . . .	76
Right Angle Specifications: VTR090-VTR010 . . . . .	77
Right Angle Specifications: VTR115-VTR018 . . . . .	78
Radial and Axial Load Ratings . . . . .	79
<b>UltraTRUE™ Helical Planetary Gearheads . . . . .</b>	<b>82</b>
UltraTRUE Size 60 . . . . .	83
UltraTRUE Size 75 . . . . .	84
UltraTRUE Size 90 . . . . .	85
UltraTRUE Size 10 . . . . .	86
UltraTRUE Size 115 . . . . .	87
UltraTRUE Size 14 . . . . .	88
UltraTRUE Size 18 . . . . .	89
UltraTRUE Size 22 . . . . .	90
Radial and Axial Load Ratings . . . . .	91
<b>UltraTRUE 90 Helical Right Angle Gearheads . . . . .</b>	<b>94</b>
UltraTRUE 90 Size 60 . . . . .	95
UltraTRUE 90 Size 75 . . . . .	96
UltraTRUE 90 Size 90 . . . . .	97
UltraTRUE 90 Size 10 . . . . .	98
UltraTRUE 90 Size 115 . . . . .	99
UltraTRUE 90 Size 14 . . . . .	100
UltraTRUE 90 Size 18 . . . . .	101
Radial and Axial Load Ratings . . . . .	102
<b>EverTRUE™ Planetary Gearheads . . . . .</b>	<b>104</b>
EverTRUE Size 10 . . . . .	105
EverTRUE Size 14 . . . . .	106
EverTRUE Size 18 . . . . .	107
Radial and Axial Load Ratings . . . . .	108
Gearhead Application Analysis Form . . . . .	110
Gearhead Ordering Information . . . . .	112
Custom Gearhead Options . . . . .	113

**Micron True Planetary® Gearheads  
shipped within 24 hours!**

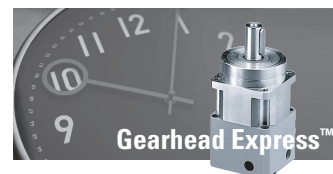

**Need it fast? Go to the back cover  
of the catalog for details.**

# Micron TRUE Planetary® Gearheads

## Product Overview

### AquaTRUE™

#### Features

- Precision: 13 arc-minutes
- Frame Sizes: 60 mm, 80 mm, 120 mm and 160 mm
- Torque Capacity: up to 876 Nm
- Ratio Availability: 3:1 thru 100:1
- Radial Load Capacity: up to 3730 N



### XTRUE™

#### Features

- Precision: 13 arc-minutes
- Frame Sizes: 40 mm, 50 mm, 60 mm, 70 mm, 80 mm, 90 mm, 120 mm and 160 mm
- Torque Capacity: up to 876 Nm
- Ratio Availability: 3:1 thru 100:1
- Radial Load Capacity: up to 3730 N

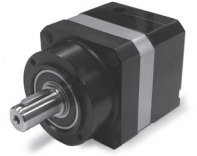

### NemaTRUE™

#### Features

- Precision: 13 arc-minutes
- Frame Sizes: 23 (2.3in), 34 (3.4in), 42(4.2in), 60mm, 90mm and 115mm
- Torque Capacity: up to 180 Nm
- Ratio Availability: 3:1 thru 100:1
- Radial Load Capacity: up to 3730 N



### NemaTRUE 90™ Right Angle

#### Features

- Precision: 13 arc-minutes
- Frame Sizes: 23 (2.3in), 34 (3.4in) and 42(4.2in)
- Torque Capacity: up to 255 Nm
- Ratio Availability: 1:1 thru 500:1
- Radial Load Capacity: up to 2900 N



### DuraTRUE™

#### Features

- Precision: 8 arc-minutes
- Frame Sizes: 60 mm, 90 mm, 115 mm and 142 mm
- Torque Capacity: up to 834 Nm
- Ratio Availability: 3:1 thru 100:1
- Radial Load Capacity: up to 11150 N



### DuraTRUE 90 Right Angle

#### Features

- Precision: 8 arc-minutes
- Frame Sizes: 60 mm, 90 mm, 115 mm and 142 mm
- Torque Capacity: up to 842 Nm
- Ratio Availability: 1:1 thru 500:1
- Radial Load Capacity: up to 11150 N



### DuraTRUE 90 Hollow Shaft

#### Features

- Precision: 8 arc-minutes
- Frame Sizes: 90 mm, 115 mm and 142 mm
- Torque Capacity: up to 865 Nm
- Ratio Availability: 1:1 thru 500:1
- Radial Load Capacity: up to 11150 N



## Product Overview

### DuraTRUE 90 Dual Shaft

#### Features

- Precision: 8 arc-minutes
- Frame Sizes: 60 mm, 90 mm, 115 mm and 142 mm
- Torque Capacity: up to 865 Nm
- Ratio Availability: 1:1 thru 500:1
- Radial Load Capacity: up to 11150 N

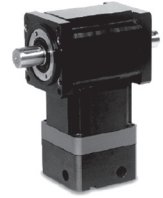

### ValueTRUE™

#### Features

- Precision: 4 arc-minutes
- Frame Sizes: 60 mm, 75 mm, 90 mm, 100 mm, 115 mm, 140 mm, 180 mm and 220 mm
- Torque Capacity: up to 2969 Nm
- Ratio Availability: 4:1 thru 100:1
- Radial Load Capacity: up to 37910 N

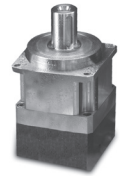

### ValueTRUE 90 Right Angle

#### Features

- Precision: 4 arc-minutes
- Frame Sizes: 60 mm, 75 mm, 90 mm, 100 mm, 115 mm, 140 mm and 180 mm
- Torque Capacity: up to 2800 Nm
- Ratio Availability: 1:1 thru 50:1
- Radial Load Capacity: up to 37910 N



### UltraTRUE™

#### Features

- Precision: 4 arc-minutes
- Frame Sizes: 60 mm, 75 mm, 90 mm, 100 mm, 115 mm, 140 mm, 180 mm and 220 mm
- Torque Capacity: up to 3300 Nm
- Ratio Availability: 4:1 thru 100:1
- Radial Load Capacity: up to 37910 N



### UltraTRUE 90 Right Angle

#### Features

- Precision: 4 arc-minutes
- Frame Sizes: 60 mm, 75 mm, 90 mm, 100 mm, 115 mm, 140 mm and 180 mm
- Torque Capacity: up to 3111 Nm
- Ratio Availability: 1:1 thru 50:1
- Radial Load Capacity: up to 37910 N

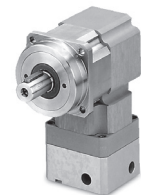

### EverTRUE™ Continuous Duty

#### Features

- Precision: 4 arc-minutes
- Frame Sizes: 100 mm, 140 mm and 180 mm
- Torque Capacity: up to 1010 Nm
- Ratio Availability: 4:1 thru 100:1
- Radial Load Capacity: up to 44600 N



# Micron TRUE Planetary® Gearheads

## True Planetary Gearhead offer...

- High Torque-to-Size Ratio - allows compact design
- Low Backlash - eliminates positioning errors due to lost motion
- Inertia Matching - keeps servo system stable and in control
- High Rigidity - optimizes system response
- Self Relubrication - eliminates costly maintenance and downtime
- High Radial Load Capacity - mount pulleys and pinions directly on the output shaft



UltraTRUE™ output cage assembly

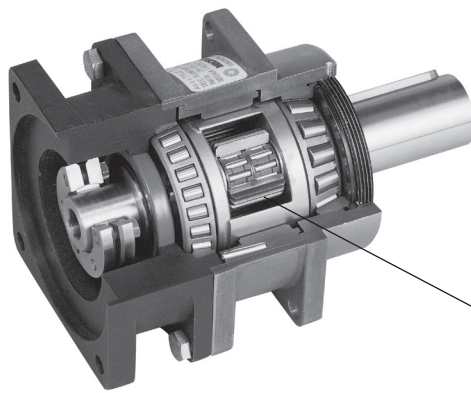

Planetary Gearing

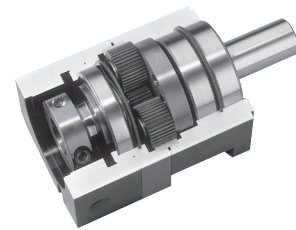

DuraTRUE™ in-line planetary gearhead

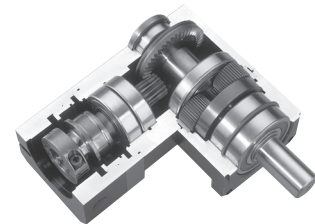

DuraTRUE 90 right angle planetary gearhead

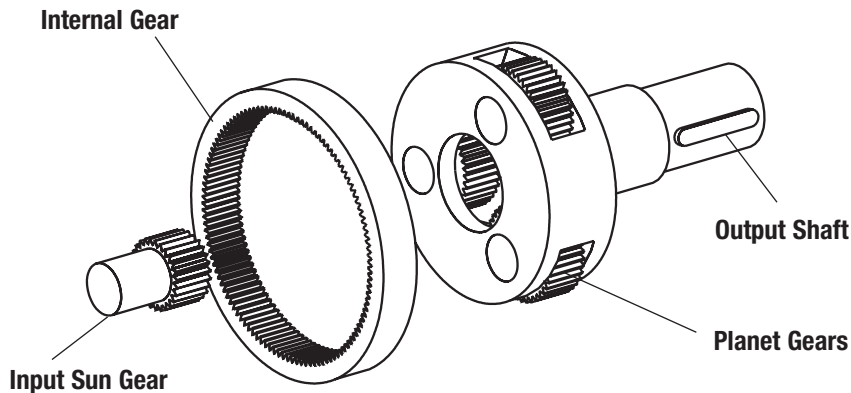

Gearhead	True Planetary gearing
AquaTRUE™	•
XTRUE™	•
NemaTRUE™	•
NemaTRUE 90	•
DuraTRUE	•
DuraTRUE 90	•
UltraTRUE	•
UltraTRUE 90	•
ValueTRUE™	•
ValueTRUE 90	•
EverTRUE™	•

## Helical Crowned True Planetary Gearing offers...

- High Torque Capacity
- Low Backlash
- Smooth Operation
- Greater Load Sharing
- Whisper Quiet

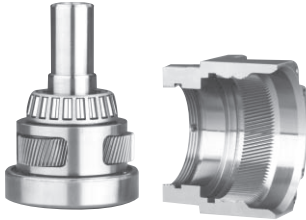

Output housing and helical internal gear are machined from a single piece of high strength steel

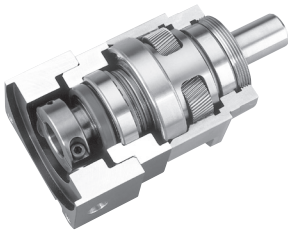

UltraTRUE in-line planetary gearhead

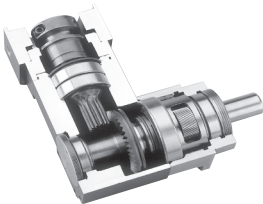

UltraTRUE 90 right angle planetary gearhead

Helical gears are known for their quiet and smooth operation along with their ability to transmit higher loads than spur gears. Both of these features of helical gearing result from the improved contact ratio (effective teeth in mesh) over spur gears. Crowning is a modification to the gear tooth profile, which optimizes gear mesh alignment. It also enhances distribution of loading on the tooth flank, thereby reducing high stress regions which can result in surface pitting.

Planetary gearheads are often selected for high-precision motion control applications, which require a high torque-to-volume ratio, high torsional stiffness and low backlash. Until now, these attributes have been sufficient to meet the requirements of the market. Thomson has designed a high-torque, whisper-quiet helical gearhead to meet the recent improvements in servo motor technology.

Thomson engineers accomplished this by combining the positive attributes of gear crowning and helical gearing with the planetary construction to create the smoothest operating gearhead on the market.

### Spur vs. Helical Gearing

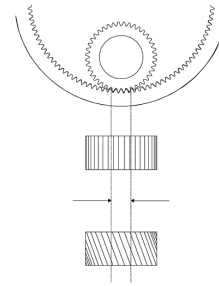

Typical contact ratio is 1.5 for spur gearing.

Contact ratio for equivalent helical gear is 3.3, more than double the contact ratio.

The contact ratio is defined as the number of teeth in mesh at any given time. The higher the contact ratio, the higher the torque rating of the gearing. **Helical gearing has more than 2X the contact ratio of spur gearing.**

### Crowned vs. Non-crowned

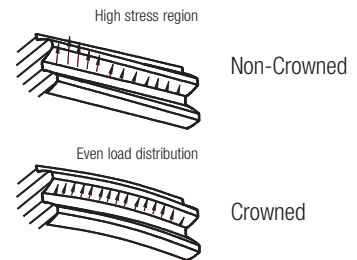

Crowning optimizes the gear mesh alignment within a gear train to increase the torque capacity and reduce noise. It also enhances load distribution on the tooth flank to reduce high stress regions.

Gearhead	Helical Crowned True Planetary gearing
AquaTRUE	
XTRUE	
NemaTRUE	
NemaTRUE 90	
DuraTRUE	
DuraTRUE 90	
UltraTRUE	•
UltraTRUE 90	•
ValueTRUE	•
ValueTRUE 90	•
EverTRUE	

# Micron TRUE Planetary® Gearheads

## PowerTRUE™ Right Angle Gearheads offer...

- Lower backlash accomplished through single-axis mesh adjustment
- A compact right-angle design utilizing a high-tech face gear
- Whisper-quiet operation due to high contact ratio
- Mesh ratios from 1:1 to 5:1
- 98% efficiency

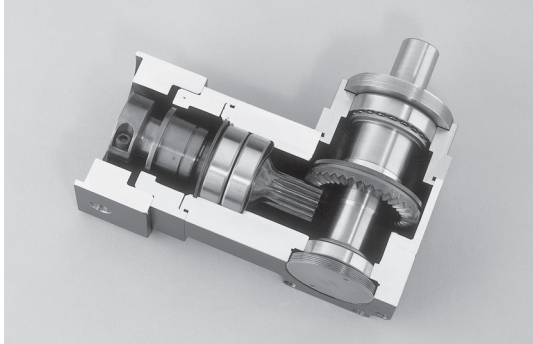

PowerTRUE Gear

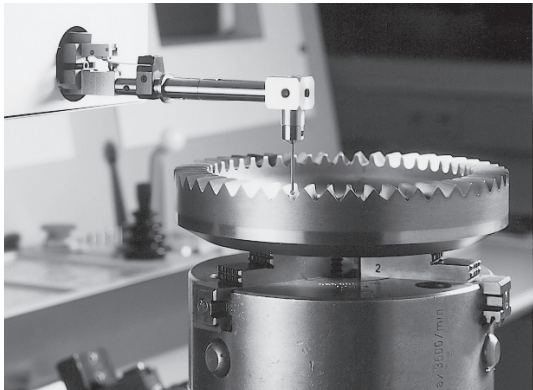

Computerized mapping of gear tooth profile

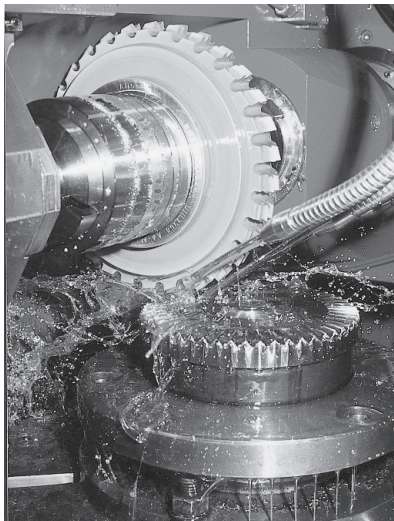

CNC machining of a PowerTRUE right-angle gear

### PowerTRUE right angle gearset

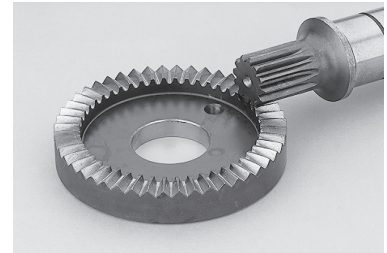

Right-angle gear meshes are typically limited to ratios from 1:1 to 3:1 when using standard bevel gears. Compared to these designs, the PowerTRUE 90 gear increases the ratio range to 5:1.

The key to higher torque density is a unique tooth design, created by complex machining made practical with advanced CNC equipment and software. In the design, multiple teeth in the face gear simultaneously mesh with a standard involute pinion. The continuous tooth engagement yields a high contact ratio between the gear and the pinion, boosting torques to new levels and efficiency to 98%.

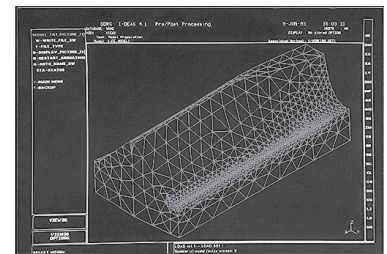

Advanced software enables stress analysis of PowerTRUE tooth profile

Gearhead	PowerTRUE gearing
AquaTRUE™	
XTRUE™	
NemaTRUE™	
NemaTRUE 90	●
DuraTRUE™	
DuraTRUE 90	●
UltraTRUE™	
UltraTRUE 90	●
ValueTRUE™	
ValueTRUE 90	●
EverTRUE™	



**Step 1:** Select the required precision class and gearhead configuration (in-line or right angle).

**Step 2:** Select the proper gearhead using exact or general method.

For continuous duty applications, please contact Applications Engineering.

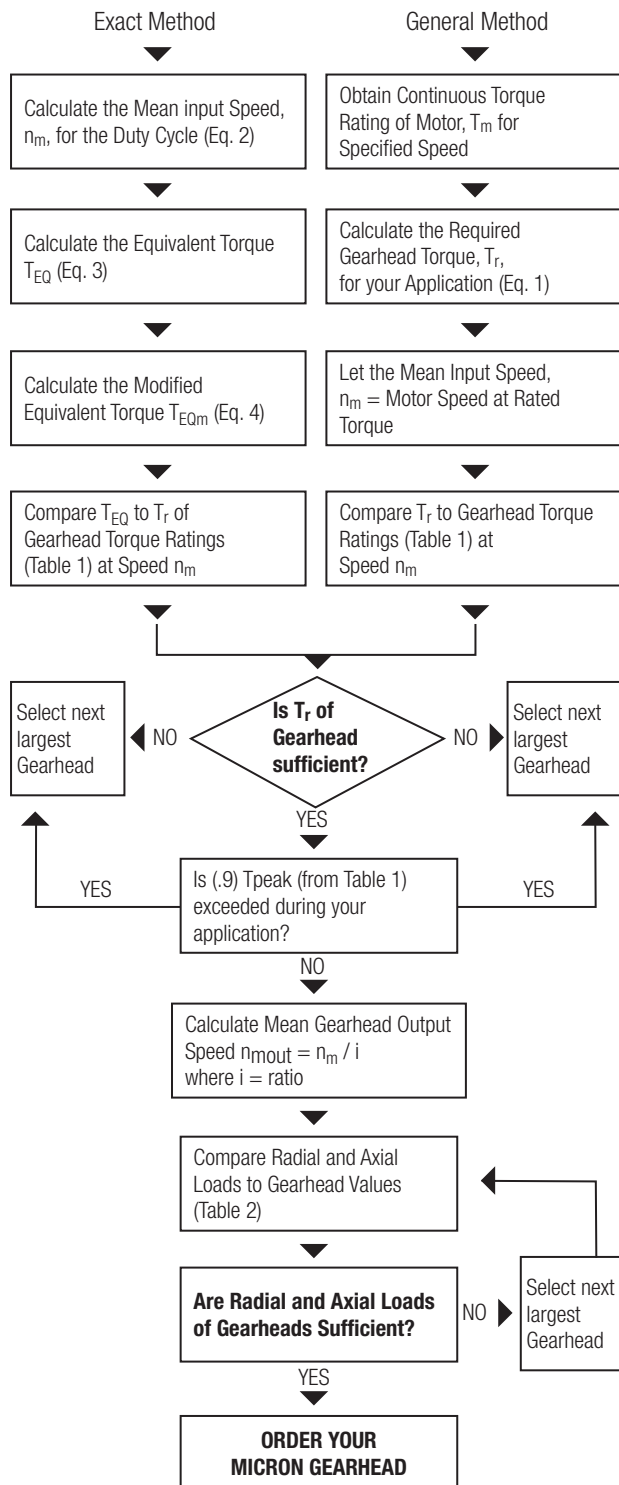

### General Method:

#### Required Gearhead Torque(T<sub>r</sub>)

$$(1) T_r = T_M^* \times i \times e$$

where:  $T_M^*$  = continuous torque of motor  
 $i$  = Gearhead ratio  
 $e$  = efficiency of Gearhead

\* Since many motors are capable of exceeding their continuous torque rating for extended lengths of time, the value for  $T_M$  will only provide a starting point for Gearhead selection. Only use the general method if the continuous motor rating is not exceeded in the application.

### Exact Method

Motion Profile

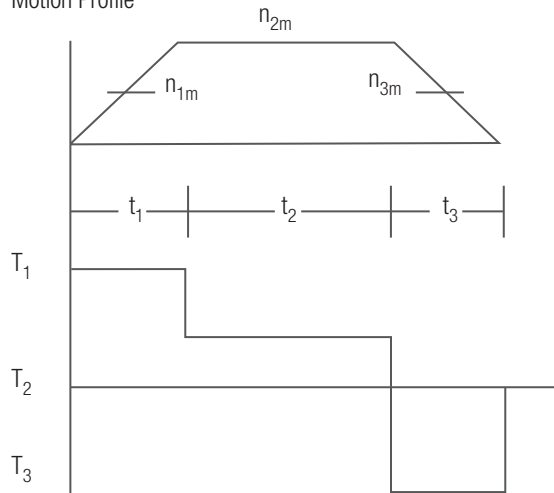

$t_n$  = time period n  
 $n_{nm}$  = mean speed during time period  $t_n$   
 $T_n$  = torque during time period  $t_n$

#### Mean input speed (n<sub>m</sub>)

$$(2) n_m = \frac{n_{1m}t_1 + n_{2m}t_2 + n_{3m}t_3 + \dots + n_{nm}t_n}{t_t}$$

where  $t_t = t_1 + t_2 + t_3 + \dots + t_n$

#### Equivalent torque (T<sub>EQ</sub>)

$$(3) T_{EQ} = \sqrt[8.7]{T_1^{8.7} \frac{n_{1m}t_1}{n_m t_t} + T_2^{8.7} \frac{n_{2m}t_2}{n_m t_t} + T_3^{8.7} \frac{n_{3m}t_3}{n_m t_t} + \dots + T_n^{8.7} \frac{n_{nm}t_n}{n_m t_t}}$$

#### Modified equivalent torque (T<sub>EQm</sub>)

$$(4) T_{EQm} = (T_{EQ})/Q$$

where Q is:

Q	# of cycles/hr
1,0	>0
0,9	>1000
0,7	>2500
0,5	>5000

For applications > 10,000 cycles/hour or for continuous duty operation, please contact application engineering.

# Micron TRUE Planetary® Gearheads

## Sizing and Selection

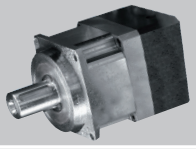
Micron® Quick Selection Guide			
Product Line		UltraTRUE™	ValueTRUE™
Prefix		UT/UTR	VT/VTR
Maximum Backlash (for the product life) <sup>(1)</sup>	[arc/min]	4/5	4/5
Lower Backlash Option		N	N
Price Relationship		1.2 ×	0.7 ×
In-line Frame Sizes / Right Angle Frame Sizes	[mm]	60 - 220 / 60 - 142	60 - 220 / 60 - 142
In-line Ratio Availability / Right Angle Ratio Availability <sup>(2)</sup>		4:1 - 100:1 / 1:1 - 50:1	4:1 - 100:1 / 1:1 - 50:1
Double Stage Available		Y	Y
Torque Capacity Relationship		2.8 ×	2.6 ×
True Planetary Gearing / Helical Crowned Gearing		Y / Y	Y / Y
Expected Noise Level	[db]	66	66
Modification Costs		Very Low	Low
Lubricated for Life		Y	Y
Efficiency	[%]	95	95
Dual and Hollow Shafts Available		N	N
Housing Material		Stainless and Aluminum	Stainless and Aluminum
3D CAD Models on Micron Motioneering		Y	Y
One Piece Output Shaft/Carrier / Internal Gear Machined into Housing		Y / Y	Y / Y
Maximum input speed <sup>(6)</sup>	[RPM]	6000	6000
ROHS Compliant <sup>(7)</sup> / Case Hardened Gears (HRC60)		Y / Y	Y / Y
Gearhead Express <sup>(5)</sup>		Y	Y
Low Temperature Grease Available / Food Grade Grease Available / NSF Certified <sup>(8)</sup>		Y / Y / N	Y / Y / N
RediMount Compliant		Y	Y

(1) Backlash is measured at the output shaft, with the input fixed, using 2 % of the rated torque in both directions.

(2) Other ratios available, contact customer support for more information.

(3) Double stage AquaTRUE now available.

(4) Lower backlash, high precision available (8/9 arc-min).

(5) Gearhead Express not available in frame sizes larger than 140 mm or dual and hollow shafts.

## 10 Reasons to Choose Micron Gearheads

### 1 RediMount™ – Fast and Error-Free Motor Mounting

The unique RediMount system will mount any Micron gearhead to any motor in just three simple steps in less than five minutes!

### 2 Easy Sizing and Selection with Micron Motioneering

Micron Motioneering is the most accurate and user-friendly gearhead sizing and design tool on the market. Try it at [www.micronmotioneering.com](http://www.micronmotioneering.com).

Easy sizing and selection with  
**[www.MicronMotioneering.com](http://www.MicronMotioneering.com)**

### 3 Superior Technology

All Micron gears are case-hardened to HRC60 for longer life. Our UltraTRUE and ValueTRUE models have a higher helix angle (15°) than our competitors' helical gearheads, resulting in less backlash, smoother and quieter operation, and longer life.

### 4 Fast Deliveries

Micron offers 1 – 2-week standard lead times on all standard catalog products. For quicker shipping, use our 24-hour "Gearhead Express" delivery service, which is available for all models for just a 10% premium!

24-hour deliveries with  
**Gearhead Express™**

				
EverTRUE™	DuraTRUE™	NemaTRUE™	XTRUE™	AquaTRUE™
ET	DT/DTR	NT/NTR	XT, XTA	AQT
4/5	8/9	13/15	13/15	13/15
N	N	Y <sup>(4)</sup>	Y <sup>(4)</sup>	Y <sup>(4)</sup>
1.5 ×	1.0 ×	0.5 ×	0.4 ×	1.5 ×
100 - 180 / -	60 - 142 / 60 - 142	60 - 115 (23 - 42) / 60 - 115 (23 - 42)	40 - 160 / -	60 - 160 / -
4:1 - 100:1 / -	3:1 - 100:1 / 1:1 - 500:1	3:1 - 100:1 / 1:1 - 500:1	3:1 - 100:1 / -	3:1 - 100:1 / -
Y	Y	Y	Y	Y <sup>(3)</sup>
2.8 ×	1.0 ×	0.7 ×	1.1 ×	1.1 ×
Y / N	Y / N	Y / N	Y / N	Y / N
68	68	68	68	68
Low	Very Low	Very Low	Low	Low
Y	Y	Y	Y	Y
95	93	93	93	93
N	Y	N	N	N
Stainless and Aluminum	Anodized Aluminum	Anodized Aluminum	Anodized Aluminum	100 % Stainless
Y	Y	Y	Y	Y
Y / Y	Y / N	Y / N	Y / N	Y / N
6000	6000	6000	6000	6000
Y / Y	Y / Y	Y / Y	Y / Y	Y / Y
Y	Y	Y	Y	N
Y / Y / N	Y / Y / N	Y / Y / N	Y / Y / N	Y / Y / Y
Y	Y	Y	Y	N

(6) Speeds greater than 6000 RPM need to be reviewed by application engineering.

(7) ROHS on right angle product is still being confirmed.

(8) The AquaTRUE is certified to NSF/ANSI STD 169.

(9) All products are dimensional drop in replacement, the catalog should be reviewed for length and width details.

### 5 Lubricated For Life

Micron gearheads require no maintenance and are grease filled. Unlike oil-filled units, they can be mounted in any orientation and will never leak.

### 6 Easy Customization

We welcome modification requests as well as "white paper" custom opportunities. The modular design of our products allows modifications to be easily implemented with small impacts to price and delivery.

### 7 Unmatched Product Breadth

Micron has the largest selection of planetary gearheads in the world with more than 3000 size and ratio combinations.

### 8 Unmatched Quality

All Micron gearheads are tested through our state-of-the-art end-of-line tester, making our outgoing quality the best in the market.

### 9 Commitment to New Product Development

Micron was first to launch an all-stainless steel, IP69K gearhead for the food and beverage market. The AquaTRUE is designed for the most harsh and corrosive environments.

### 10 Made in the USA

All Micron Gearheads are manufactured in the USA, making us able to respond to emergencies quickly and reducing downtime for our customers.

# Micron TRUE Planetary® Gearheads

## Micron MOTIONEERING®

The web-based sizing tool for Micron TRUE Planetary Gearheads

**Have Micron MOTIONEERING do the application engineering work for you!**

**A way to optimize your machine design, save time and, ultimately, help you build a better machine, faster. Easy to use and it's free at [www.MicronMOTIONEERING.com](http://www.MicronMOTIONEERING.com)**

**Micron MOTIONEERING has three different modes of functionality:**

### 1. Select By Requirements

Enter your application requirements in just a few easy steps to find the right gearhead for your application in the "Select by Requirements" section.

### 2. Select by Competitor Gearhead

Need a replacement for your current gearhead? Use our handy matrix to find the perfect drop-in replacement in only seconds.

### 3. Select by Model Number

Search by product line, model number, frame size and ratio in the "Select by Model Number" section. Micron MOTIONEERING quickly provides a complete part number, pricing and delivery information. 3D models are also available for immediate download.

- Don't know your RediMount? Choose from hundreds of the most popular motors on the market today or enter in your motor dimensions manually.

- Not sure if your motor fits on a specific gearhead? The tool will let you know if you have chosen a combination that is outside of the standard guidelines.

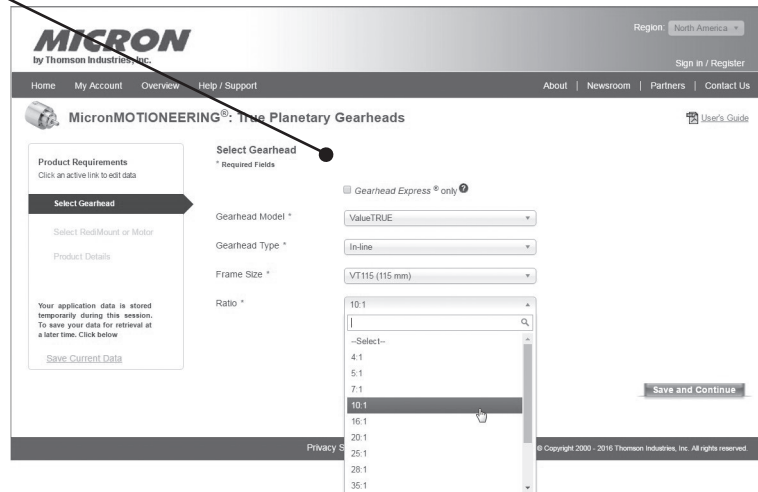
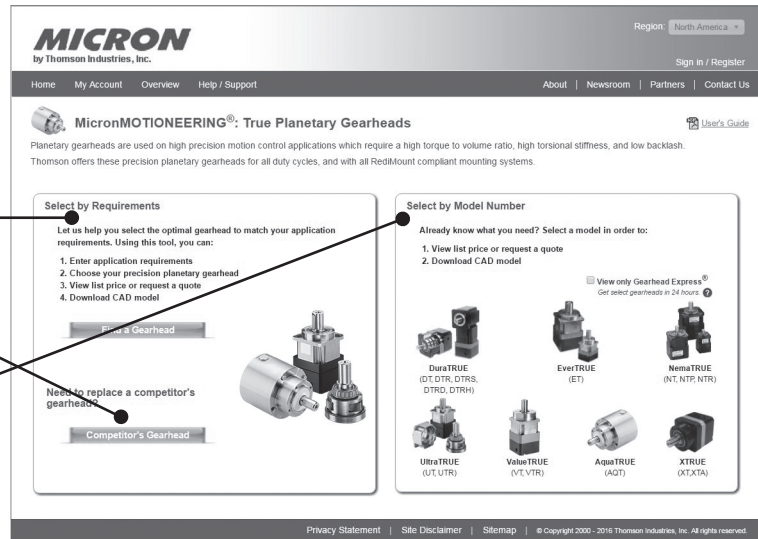

### Do you need to cross over a competitor's product?

The Micron MOTIONEERING tool features a competitive replacement function that allows you to accurately, quickly and easily cross over all major competitor gearheads.

### Gearhead Sizing and Selection

Follow these easy steps for sizing and selection:

- Select orientation (in-line or right angle).
- Select backlash requirement.
- Select from all of the ratios available for that combination.
- Select operation type whether cyclical or continuous duty.
- Select a specific torque and speed requirement or build an entire motion profile.
- If needed, you may account for radial and axial loads on the output shaft.
- The tool will calculate your  $T_{eq}$  (equivalent torque) and display only solutions that will work in your application.
- If you do not know your RediMount, you can choose from a list of the most popular motors on the market today or enter your motor dimensions manually.
- Double check your configuration on the “Review

Page.” Click any parameter to quickly edit if needed then view solutions to reveal a list available solutions, sorted by Gearhead Express Eligibility. You can also sort by any of the listed columns.

- The torque safety factor will also be listed for each solution to help maximize the gearhead life.
- The final output delivers pricing, a printable summary of the design solution, and the ability to save it for future use.
- Also available are 3D models of your unique solution in neutral file formats or native CAD files for all major software packages (25+ formats available).

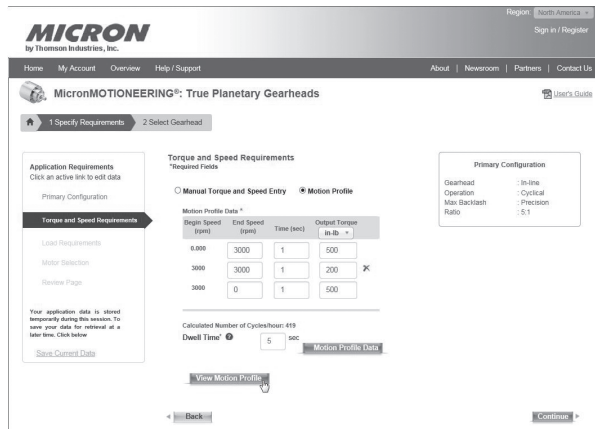

Use the Micron MOTIONEERING tool to help you build your motion profile.

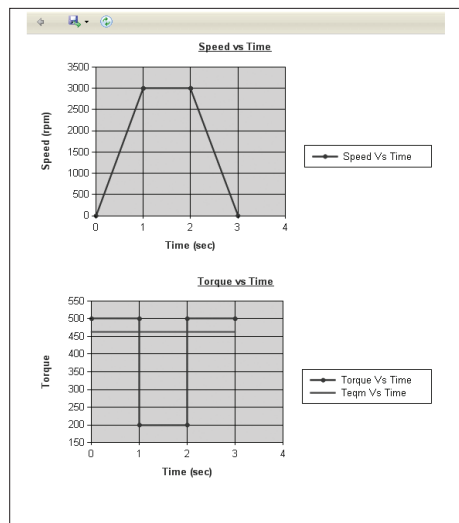

### Get started with Micron MOTIONEERING today!

- The Micron MOTIONEERING tool is very easy to use and is the fastest way to accurately size and select your next gearhead.
- Save money by seeing all the possible choices.
- Automatic calculations ensure the correct solution to fit your requirements.
- It does all of the work for you and gives you the correct solution to fit your requirements.

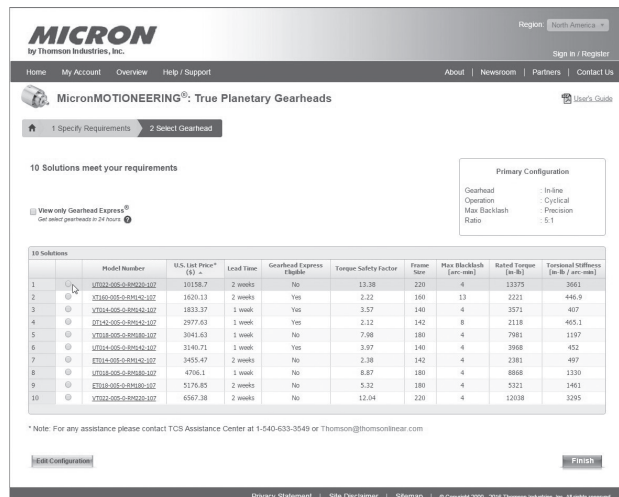

# Micron TRUE Planetary® Gearheads

## RediMount™ Motor Mounting System

### Mounting Instructions

1. Slide the provided sleeve into the hub and align the slot in the bushing with the slot in the hub.
2. Set the motor on a work surface or hold fixture with the output shaft facing straight up. If there is a key on the motor, remove it and align the keyway with the slot in the hub. Slide the gearhead down onto the motor shaft.
3. Rotate the hub to align the input housing access holes with the hub clamping bolts.
4. Using a torque wrench, tighten the hub bolts to the pre-torque value indicated in the table.
5. Bolt the motor to the gearhead with the bolts provided.
6. Gradually tighten the hub bolts in three steps, increasing the torque each time until reaching the final tightening torque in the table.
7. Incorrectly mounted motor and gearbox void the warranty

### Hub Bolt Tightening Torques

Gearhead Model	Gearhead Frame Size	Pre-Tightening Torque		Final Tightening Torque	
		in.-lb.	[Nm]	in.-lb.	[Nm]
AquaTRUE™	060	2	0.2	39	4.4
	080	4	0.4	76	8.5
	120	16	1.8	316	36
	160	32	3.6	636	72
NemaTRUE™ NemaTRUE 90	23/60	2	0.2	39	4.4
	34/90	4	0.4	76	8.5
	42/115	16	1.8	316	36.0
DuraTRUE™ DuraTRUE 90	060	2	0.2	39	4.4
	090	4	0.4	76	8.5
	115	16	1.8	316	36.0
	142	32	3.6	636	72.0
UltraTRUE™ UltraTRUE 90 ValueTRUE™ ValueTRUE90 EverTRUE™	006	2	0.2	39	4.4
	075/090	4	0.4	76	8.5
	010/115	16	1.8	316	36.0
	014	32	3.6	636	72.0
	018/022	55	6.3	1104	125.0
XTRUE™ (XT/XTA)	040/050	0.5	0.05	9.6	1.09
	060/070	2	0.2	39	4.4
	080/090	4	0.4	76	8.5
	120	16	1.8	316	36
	160	32	3.6	636	72

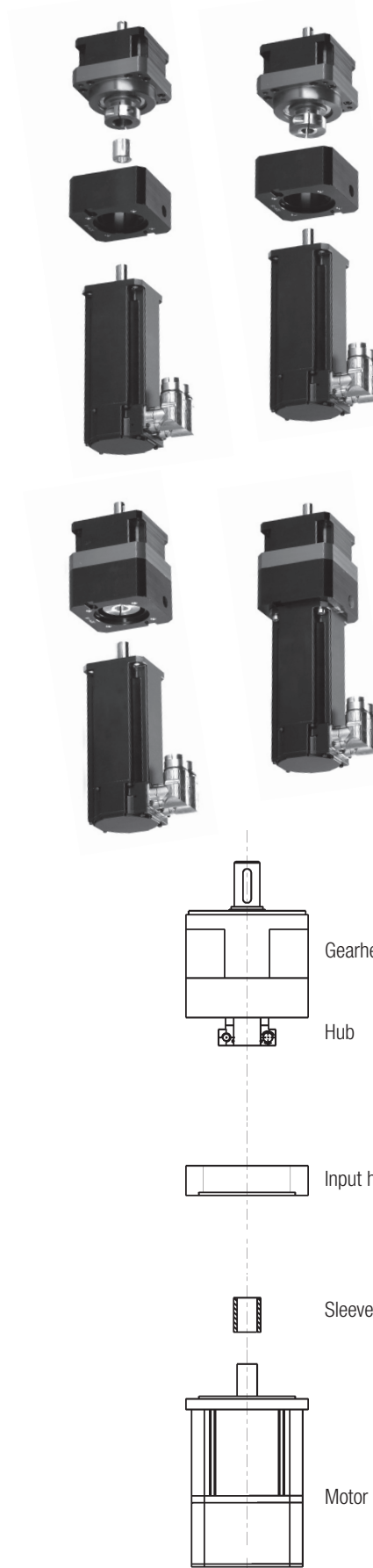

Gearhead must be mounted in vertical orientation.

### True Planetary Gearheads

<b>Ready for Immediate Delivery</b>	
<b>Precision</b>	13 arc-minutes
<b>Frame Sizes</b>	60 mm, 80 mm, 120 mm and 160 mm
<b>Torque Capacity</b>	up to 876 Nm
<b>Ratio Availability</b>	3:1 thru 100:1
<b>Radial load capacity</b>	up to 3730 N
<b>Mounting System</b>	RediMount™

① Silicone Gasket to Seal Motor-Gearhead Interface

② Round and Square Motor Mounts

③ 1pc Housing - No External Seams

④ Permanent Product Label  
(Laser Etched)

⑤ Tested for IP66, IP67 and IP69K Protection  
Throughout

⑥ 300 Series Stainless Steel Housing

⑦ Contact Lip Seal for Maximum Protection

⑧ Stainless Steel Output Shaft

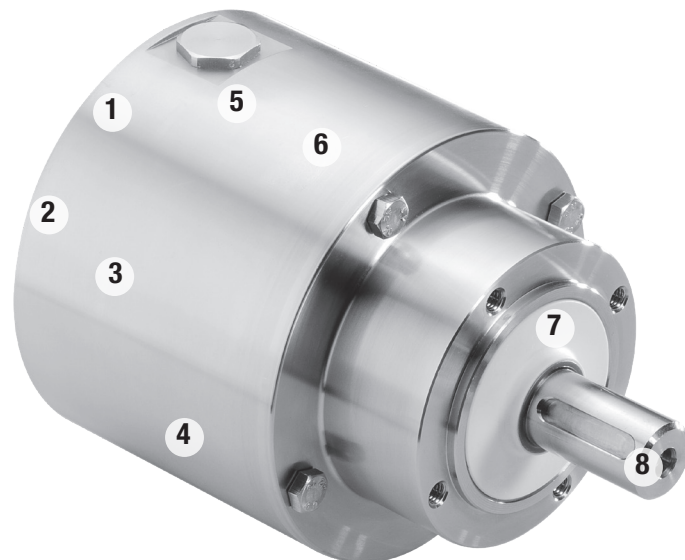

# Micron TRUE Planetary® Gearheads

---

## AquaTRUE™

A revolutionary, corrosion resistant and watertight gearhead for the most demanding applications.

## Introduction

Micron's AquaTRUE gearhead combines the high performance and torque capacity of Micron's TRUE Planetary gearheads with features specifically designed to meet the strict requirements of applications such as food and beverage handling, packaging and dispensing. The AquaTRUE's IP66/IP67 and IP69K protection is able to handle caustic cleaning chemicals as well as high pressure washdown. Until now, manufacturers have been unable to use gearheads in many applications involving harsh environments because there was not a product available that met those needs. The AquaTRUE is engineered to be placed anywhere in the application's design, regardless of environmental factors. This eliminates the cost of additional components such as enclosers, shielding or mechanical transmissions.

The gearhead's 304 stainless steel housing eliminates the concern for rust or any type of corrosion. The AquaTRUE has a laser etched permanent product label and a smooth, round external housing that is designed without any external seams or corners for bacteria to collect. This makes the AquaTRUE very easy to clean and a perfect fit in any washdown environment.

- Frame Sizes: 60, 80, 120 and 160 mm
- Precision: 13 arc-min max
- Torque Capacity: up to 876 Nm
- Ratio Availability: 3:1 to 10:1 (single stage), 15:1 to 100:1 (double stage)

## Features and Benefits

- Round housing
- No external seams
- 300 Series stainless steel
- IP66/IP67 and IP69K protection on both the input and output
- NSF/ANSI 169 certification
- No corners or areas for bacteria to collect
- No areas of ingress
- Corrosion resistance
- Can handle high-pressure washdown





### True Planetary Gearheads

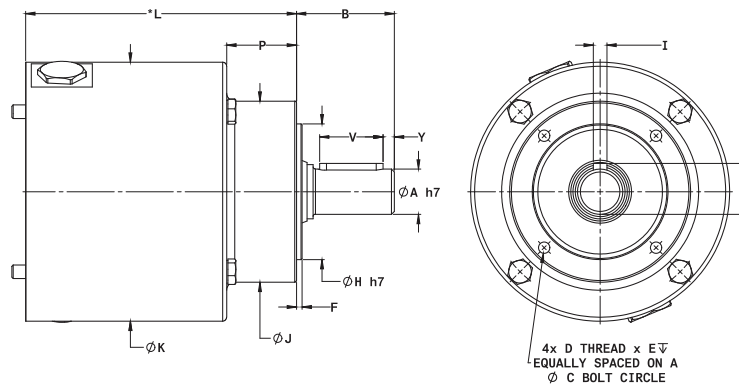

\* 'L' Dimension will change depending on motor being used.  
 Note: Mounting adapters available for both round and square motors.

### Dimensions

Part Number	A Output Shaft Diameter mm [in.]	B Output Shaft Length mm [in.]	Y Shaft End Distance mm [in.]	V Keyway Length mm [in.]	R Keyway Height mm [in.]	I Key Width mm [in.]	H Pilot Diameter mm [in.]	J Body Diameter mm [in.]
AQT060	14 [0.55]	36.8 [1.45]	2.5 [0.10]	25 [0.98]	16 [0.63]	5 [0.20]	43 [1.69]	60 [2.36]
AQT080	20 [0.79]	43.2 [1.70]	4.0 [0.16]	28 [1.10]	22.5 [0.89]	6 [0.24]	60 [2.36]	80 [3.15]
AQT120	25 [0.98]	58.4 [2.30]	5 [0.20]	40 [1.57]	28 [1.10]	8 [0.31]	80 [3.15]	110.5 [4.36]
AQT160	40 [1.57]	90.3 [3.56]	8.0 [0.32]	65 [2.55]	43 [1.69]	12 [0.47]	105 [4.13]	140 [5.50]

Part Number	F Pilot Length mm [in.]	D Output Housing Thread	E Thread Depth mm [in.]	K Input Body Diameter mm [in.]	* L Standard Length mm [in.]		C Bolt Circle mm [in.]	P Output Body Length mm [in.]
					ratio 3:1 - 10:1	ratio 15:1 - 100:1		
AQT060	2.5 [0.098]	M5x0.8-6H	8.1 [0.32]	92 [3.62]	91.7 [3.61]	109 [4.29]	52 [2.05]	38.5 [1.51]
AQT080	2.5 [0.098]	M6x1.0-6H	10.1 [0.40]	114.5 [4.51]	119.7 [4.71]	142.7 [5.62]	70 [2.76]	30.8 [1.21]
AQT120	4.0 [0.157]	M10x1.5-6H	16 [0.63]	150 [5.9]	148.2 [5.83]	179.3 [7.06]	95 [3.74]	56.1 [2.21]
AQT160	5.0 [0.197]	M12x1.75-6H	21.6 [0.85]	188.7 [7.43]	195.8 [7.71]	243.8 [9.60]	124 [4.88]	76 [2.99]

### Specifications

Part Number	Stages	Backlash (arc-min)	Efficiency	Weight		Ratio Availability
				kg	[lbs.]	
AQT060	1	13	93%	2.4	[5.4]	3:1, 4:1, 5:1, 7:1; 10:1
	2	15	88%	3.3	[7.3]	15:1, 20:1, 25:1, 30:1, 40:1, 50:1; 70:1; 100:1
AQT080	1	13	93%	5.7	[12.7]	3:1, 4:1, 5:1, 7:1; 8:1; 10:1
	2	15	88%	7.2	[15.9]	15:1, 20:1, 25:1, 30:1, 40:1, 50:1; 70:1; 80:1; 100:1
AQT120	1	13	93%	12.0	[26.5]	3:1, 4:1, 5:1, 7:1; 10:1
	2	15	88%	15.4	[33.9]	15:1, 20:1, 25:1, 30:1, 40:1, 50:1; 70:1; 100:1
AQT160	1	13	93%	24.8	[53.8]	3:1, 4:1, 5:1, 7:1; 10:1
	2	15	88%	31.2	[68.8]	15:1, 20:1, 25:1, 30:1, 40:1, 50:1; 70:1; 100:1

$T_r$  = Rated output torque at rated speed for specific hours of life.  
 $T_{peak}$  = Allowable momentary peak torque for emergency stop or heavy shock loading.  
 $J$  = Mass moment of inertia reflected to the input shaft (including pinion assembly).  
 Specifications subject to change without notice.

# Micron TRUE Planetary® Gearheads

## AquaTRUE™

### True Planetary Gearheads

#### Performance Specifications

Part Number	Ratio	20,000 Hour Life				T Peak Nm [in.-lb.]	J kg-cm <sup>2</sup> [in.-lb. sec <sup>2</sup> *10 <sup>-4</sup> ]	Torsional Stiffness Nm/arc-min [in.-lb./arc-min]	
		Tr (1000 rpm) Nm [in.-lb.]	Tr (2000 rpm) Nm [in.-lb.]	Tr (3000 rpm) Nm [in.-lb.]	Tr (4000 rpm) Nm [in.-lb.]				
AQT060	AQT060-003	3:1	16 [139]	13 [112]	12 [102]	11 [93]	55 [483]	0.572 [5.066]	1.49 [13.17]
	AQT060-004	4:1	20 [177]	17 [149]	15 [130]	14 [121]	46 [409]	0.457 [4.047]	1.47 [12.97]
	AQT060-005	5:1	18 [158]	15 [130]	13 [112]	12 [102]	48 [427]	0.408 [3.615]	1.45 [12.79]
	AQT060-007	7:1	17 [149]	14 [121]	12 [102]	11 [93]	43 [381]	0.367 [3.245]	1.40 [12.41]
	AQT060-010	10:1	16 [139]	15 [130]	14 [121]	13 [112]	47 [418]	0.347 [3.068]	1.36 [12.07]
	AQT060-015	15:1	26 [232]	21 [186]	19 [167]	17 [149]	55 [483]	0.387 [3.424]	1.49 [13.14]
	AQT060-020	20:1	27 [242]	25 [223]	22 [195]	21 [186]	48 [427]	0.385 [3.408]	1.47 [13.00]
	AQT060-025	25:1	25 [223]	23 [204]	20 [177]	19 [167]	55 [483]	0.384 [3.400]	1.45 [12.85]
	AQT060-030	30:1	29 [260]	26 [232]	23 [204]	21 [186]	55 [483]	0.340 [3.006]	1.49 [13.18]
	AQT060-040	40:1	28 [251]	27 [242]	27 [242]	25 [223]	48 [427]	0.339 [3.002]	1.47 [13.04]
AQT060-050	50:1	26 [232]	25 [223]	25 [223]	23 [204]	55 [483]	0.339 [3.001]	1.46 [12.88]	
AQT060-070	70:1	25 [223]	24 [214]	24 [214]	22 [195]	48 [427]	0.339 [2.999]	1.38 [12.23]	
AQT060-100	100:1	21 [186]	20 [177]	19 [167]	18 [158]	43 [381]	0.339 [2.998]	1.29 [11.41]	
AQT080	AQT080-003	3:1	59 [520]	48 [427]	43 [381]	39 [344]	165 [1459]	2.433 [21.5]	6.21 [54.96]
	AQT080-004	4:1	70 [623]	58 [511]	53 [465]	48 [427]	165 [1459]	1.929 [17.1]	6.19 [54.81]
	AQT080-005	5:1	65 [576]	53 [465]	47 [418]	43 [381]	165 [1459]	1.692 [15.0]	6.12 [54.18]
	AQT080-007	7:1	63 [558]	50 [446]	45 [400]	40 [353]	165 [1459]	1.472 [13.0]	5.70 [50.41]
	AQT080-008	8:1	62 [549]	49 [434]	45 [398]	42 [372]	165 [1460]	1.426 [12.6]	5.53 [48.98]
	AQT080-010	10:1	54 [474]	48 [427]	45 [400]	43 [381]	165 [1459]	1.387 [12.3]	5.83 [51.62]
	AQT080-015	15:1	90 [799]	78 [688]	69 [613]	63 [558]	175 [1552]	1.605 [14.2]	6.18 [54.70]
	AQT080-020	20:1	92 [818]	88 [781]	81 [716]	75 [660]	175 [1552]	1.598 [14.1]	6.18 [54.67]
	AQT080-025	25:1	87 [771]	83 [734]	76 [669]	69 [613]	175 [1552]	1.594 [14.1]	6.11 [54.10]
	AQT080-030	30:1	100 [883]	90 [799]	85 [753]	78 [688]	175 [1552]	1.367 [12.1]	6.18 [54.68]
AQT080-040	40:1	96 [846]	92 [818]	90 [799]	88 [781]	175 [1552]	1.365 [12.1]	6.18 [54.67]	
AQT080-050	50:1	90 [799]	87 [771]	85 [753]	83 [734]	175 [1552]	1.364 [12.1]	6.11 [54.10]	
AQT080-070	70:1	88 [781]	85 [753]	83 [734]	82 [725]	175 [1552]	1.363 [12.1]	5.37 [48.28]	
AQT080-080	80:1	84 [743]	80 [708]	78 [690]	74 [655]	175 [1549]	1.363 [12.1]	5.33 [47.21]	
AQT080-100	100:1	72 [641]	67 [595]	63 [558]	61 [539]	175 [1552]	1.363 [12.1]	5.58 [49.34]	
AQT120	AQT120-003	3:1	90 [799]	74 [650]	65 [576]	59 [520]	298 [2639]	9.014 [79.8]	13.58 [120.15]
	AQT120-004	4:1	107 [948]	89 [790]	79 [697]	74 [650]	298 [2639]	7.286 [64.5]	13.49 [119.36]
	AQT120-005	5:1	99 [873]	81 [716]	71 [632]	65 [576]	298 [2639]	6.484 [57.4]	13.37 [118.32]
	AQT120-007	7:1	97 [855]	79 [697]	68 [604]	63 [558]	298 [2639]	5.746 [50.9]	12.96 [114.65]
	AQT120-010	10:1	87 [771]	79 [697]	74 [650]	69 [613]	298 [2639]	5.376 [47.6]	12.12 [107.27]
	AQT120-015	15:1	146 [1292]	119 [1050]	105 [929]	96 [846]	298 [2639]	6.161 [54.5]	13.40 [118.60]
	AQT120-020	20:1	169 [1496]	139 [1227]	124 [1097]	114 [1013]	298 [2639]	6.137 [54.3]	13.32 [117.90]
	AQT120-025	25:1	161 [1422]	130 [1152]	116 [1022]	106 [939]	298 [2639]	6.199 [54.9]	13.38 [118.36]
	AQT120-030	30:1	180 [1589]	146 [1292]	129 [1143]	119 [1050]	298 [2639]	5.298 [46.9]	13.39 [115.53]
	AQT120-040	40:1	187 [1654]	169 [1496]	150 [1329]	139 [1227]	298 [2639]	5.292 [46.8]	13.47 [119.22]
AQT120-050	50:1	179 [1580]	161 [1422]	142 [1254]	130 [1152]	298 [2639]	5.289 [46.8]	13.40 [118.57]	
AQT120-070	70:1	176 [1561]	159 [1403]	140 [1236]	128 [1134]	298 [2639]	5.274 [46.7]	13.00 [115.05]	
AQT120-100	100:1	120 [1059]	109 [966]	104 [920]	100 [883]	298 [2639]	5.281 [46.7]	12.22 [108.18]	
AQT160	AQT160-003	3:1	317 [2806]	257 [2277]	228 [2016]	209 [1849]	876 [7750]	36.396 [322.13]	46.71 [413.39]
	AQT160-004	4:1	371 [3280]	305 [2695]	272 [2407]	251 [2221]	876 [7750]	26.642 [235.80]	46.16 [408.73]
	AQT160-005	5:1	350 [3094]	284 [2509]	251 [2221]	230 [2035]	876 [7750]	22.246 [196.89]	45.43 [402.08]
	AQT160-007	7:1	344 [3048]	278 [2463]	246 [2174]	225 [1989]	876 [7750]	18.551 [164.19]	43.44 [384.46]
	AQT160-010	10:1	222 [1961]	198 [1756]	185 [1635]	175 [1552]	876 [7750]	16.606 [146.97]	40.98 [362.68]
	AQT160-015	15:1	508 [4498]	417 [3689]	370 [3271]	339 [3001]	876 [7750]	19.892 [176.06]	45.19 [399.89]
	AQT160-020	20:1	513 [4544]	481 [4256]	428 [3791]	395 [3494]	876 [7750]	19.721 [174.55]	46.39 [410.38]
	AQT160-025	25:1	492 [4358]	460 [4070]	407 [3605]	374 [3308]	876 [7750]	19.632 [173.75]	45.62 [403.72]
	AQT160-030	30:1	562 [4971]	508 [4498]	455 [4024]	417 [3689]	876 [7750]	15.971 [141.36]	46.82 [413.83]
	AQT160-040	40:1	536 [4739]	513 [4544]	500 [4423]	481 [4256]	876 [7750]	15.971 [141.36]	46.37 [410.36]
AQT160-050	50:1	515 [4553]	492 [4358]	479 [4237]	460 [4070]	876 [7750]	15.971 [141.35]	45.60 [403.59]	
AQT160-070	70:1	509 [4507]	487 [4312]	474 [4191]	455 [4024]	876 [7750]	15.952 [141.18]	45.53 [385.27]	
AQT160-100	100:1	306 [2704]	279 [2472]	265 [2342]	254 [2249]	876 [7750]	15.941 [141.09]	40.95 [362.45]	

T<sub>r</sub> = Rated output torque at rated speed for specific hours of life.

T<sub>peak</sub> = Allowable momentary peak torque for emergency stop or heavy shock loading.

J = Mass moment of inertia reflected to the input shaft (including pinion assembly).

Specifications subject to change without notice.

### True Planetary Gearheads

## Radial and Axial Load Ratings

### AQT060

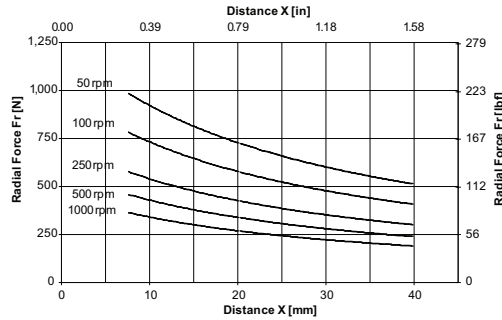
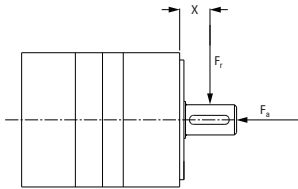

Speed rpm	Axial Load, $F_a$ N [lb.]
50	2542 [571]
100	2017 [454]
250	1486 [334]
500	1180 [265]
1000	936 [211]

### AQT080

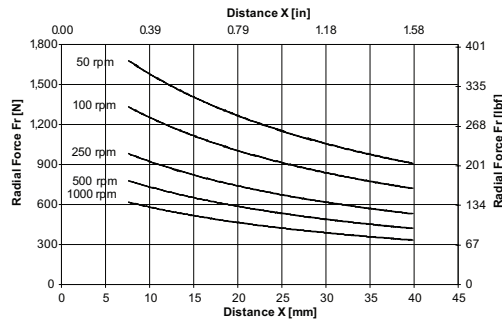
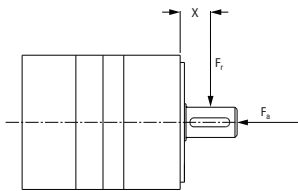

Speed rpm	Axial Load, $F_a$ N [lb.]
50	3780 [850]
100	3000 [675]
250	2211 [497]
500	1755 [394]
1000	1393 [313]

### AQT120

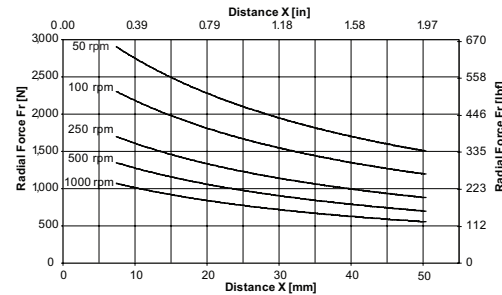
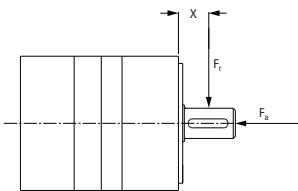

Speed rpm	Axial Load, $F_a$ N [lb.]
50	6894 [1550]
100	5471 [1230]
250	4034 [907]
500	3203 [720]
1000	2540 [571]

### AQT160

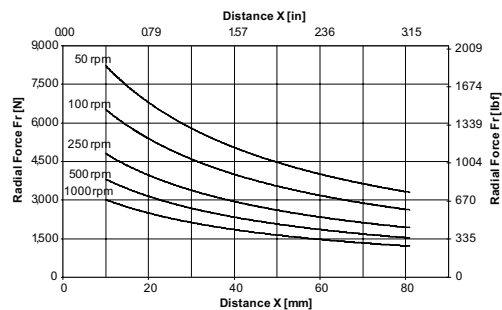
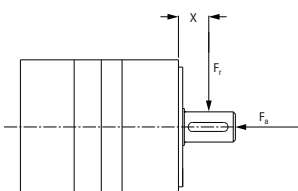

Speed rpm	Axial Load, $F_a$ N [lb.]
50	14,122 [3175]
100	11,209 [2520]
250	8260 [1857]
500	6556 [1474]
1000	5204 [1170]

These graphs display the allowable radial load at a given distance (X) from the mounting surface based on an  $L_{10}$  life of 20,000 hours for the mean output speed.

# Micron TRUE Planetary® Gearheads

## XTRUE™

### True Planetary Gearheads

Ready for Immediate Delivery	
Precision	13 arc-minutes
Frame Sizes	40 mm, 50 mm, 60 mm, 70 mm , 80 mm, 90 mm, 120 mm and 160 mm
Torque Capacity	up to 876 Nm
Ratio Availability	3:1 thru 100:1
Radial load capacity	up to 3730 N
Mounting System	RediMount™

- 1 Sealed deep groove ball bearings**  
provide high radial load carrying capability
- 2 HRC 55-60 steel gears**  
provide superior wear resistance  
and increased backlash integrity
- 3 Sealed deep groove ball bearing**  
provides precision alignment of sun gear
- 4 RediMount™ system**  
provides error-free motor installation
- 5 Anodized aluminum housing**  
reduces weight and prevents corrosion

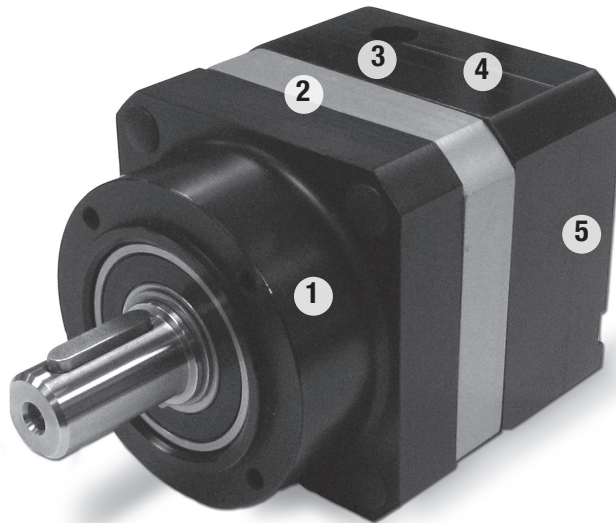

*Micron True Planetary® Gearheads  
shipped within 24 hours!*

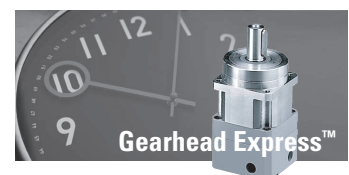

*Need it fast? Go to the back cover  
of the catalog for details.*

## True Planetary Gearheads

### Introduction

The XTRUE Series is a new precision gearhead that complements our True Planetary gearhead line, already the largest selection of planetary gearheads in the world.

### Features and Benefits

- Frame sizes (8): 40mm, 50 mm, 60mm, 70 mm, 80mm, 90 mm, 120mm and 160mm
- Precision: 13 arc-mins
- Torque capacity: up to 876 Nm
- Ratio availability: 3:1 thru 100:1
- Move a larger load more easily and quietly with True Planetary gearing through improved load capacity, lower backlash and quieter operation.
- Experience less downtime with the flexible mounting system: RediMount system mounts to any motor in three easy steps: align, mount and tighten.
- Simplify replacement with the tapped face output, which enables easy drop-in replacement.
- Go green on your machine when the assembly and all components meet EU Directive 2002/95/EC (RoHS)

# Micron TRUE Planetary® Gearheads

## XTRUE™

### True Planetary Gearheads

XT

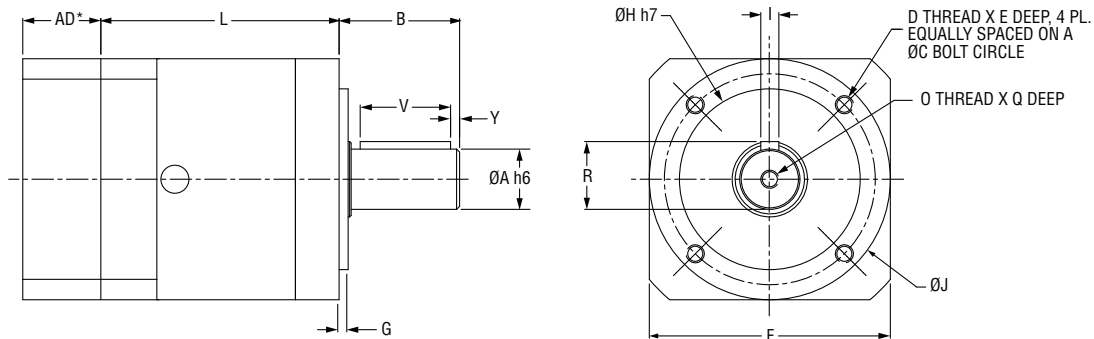

\*AD = Adapter Length  
Adapter Length will vary depending on motor. Consult customer service for details.

### Dimensions

Part Number	A Output Shaft Diameter mm [in.]	B Output Shaft Length mm [in.]	Y Shaft End Distance mm [in.]	V Keyway Length mm [in.]	R Keyway Height mm [in.]	I Key Width mm [in.]	H Pilot Diameter mm [in.]	J Body Diameter mm [in.]	G Pilot Length mm [in.]
XT040	10 [0.39]	26 [1.02]	2.5 [0.10]	18 [0.71]	11.2 [0.44]	3 [0.12]	26 [1.02]	40 [1.57]	2 [0.08]
XT060	14 [0.55]	35 [1.37]	2.5 [0.10]	25 [0.98]	16 [0.63]	5 [0.20]	40 [1.57]	60 [2.36]	3 [0.12]
XT080	20 [0.79]	40 [1.57]	4.0 [0.16]	28 [1.10]	22.5 [0.89]	6 [0.24]	60 [2.36]	80 [3.15]	3 [0.12]
XT120	25 [0.98]	55 [2.16]	5.0 [0.20]	40 [1.57]	28 [1.10]	8 [0.31]	80 [3.15]	115 [4.53]	4 [0.16]
XT160	40 [1.57]	87 [3.42]	8.0 [0.32]	65 [2.55]	43 [1.69]	12 [0.47]	130 [5.12]	160 [6.30]	5 [0.20]

### Dimensions

Part Number	D Thread	E Thread Depth mm [in.]	O Output Shaft Thread	Q Thread Depth mm [in.]	F Flange Square mm [in.]	L Length mm [in.]		C Bolt Circle mm [in.]
						3:1 - 10:1	15:1 - 100:1	
XT040	M4	6 [0.24]	M3	9 [0.35]	42 [1.65]	36.5 [1.43]	49.5 [1.94]	34 [1.34]
XT060	M5	8 [0.31]	M5	12 [0.47]	61 [2.40]	51 [2.00]	68 [2.67]	52 [2.05]
XT080	M6	10 [0.39]	M6	16 [0.63]	90 [3.54]	67 [2.64]	90 [3.54]	70 [2.76]
XT120	M10	16 [0.63]	M10	22 [0.87]	119 [4.53]	87.3 [3.44]	179 [4.67]	100 [3.94]
XT160	M12	20 [0.79]	M16	36 [1.42]	142 [5.59]	119.6 [4.71]	168.9 [6.65]	145 [5.71]

### Specifications

Part Number	Stages	Backlash (arc-min)	Efficiency	Weight		Ratio Availability
				kg	[lbs.]	
XT040	1	13	93%	0.45	[1.0]	3:1, 4:1, 5:1, 7:1, 10:1
	2	15	88%	0.5	[1.1]	15:1, 20:1, 25:1, 30:1, 40:1, 50:1, 70:1, 100:1
XT060	1	13	93%	1.0	[2.2]	3:1, 4:1, 5:1, 7:1, 10:1
	2	15	88%	1.2	[2.6]	15:1, 20:1, 25:1, 30:1, 40:1, 50:1, 70:1, 100:1
XT080	1	13	93%	3.0	[6.6]	3:1, 4:1, 5:1, 7:1, 8:1, 10:1
	2	15	88%	3.7	[8.1]	15:1, 20:1, 25:1, 30:1, 40:1, 50:1, 70:1, 80:1, 100:1
XT120	1	13	93%	5.7	[12.5]	3:1, 4:1, 5:1, 7:1, 10:1
	2	15	88%	7.3	[16.1]	15:1, 20:1, 25:1, 30:1, 40:1, 50:1, 70:1, 100:1
XT160	1	13	93%	12.8	[28.2]	3:1, 4:1, 5:1, 7:1, 10:1
	2	15	88%	17.2	[37.8]	15:1, 20:1, 25:1, 30:1, 40:1, 50:1, 70:1, 100:1

Specifications subject to change without notice.

### True Planetary Gearheads

XTA

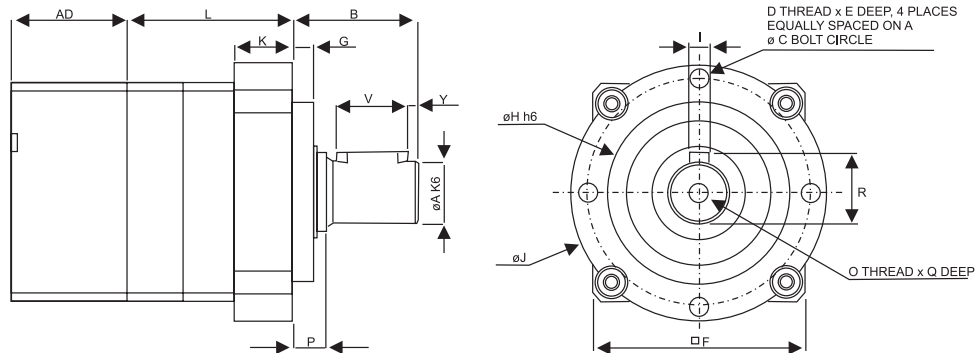

\*AD = Adapter Length  
Adapter Length will vary depending on motor. Consult customer service for details.

### Dimensions

Part Number	A Output Shaft Diameter mm [in.]	B Output Shaft Length mm [in.]	Y Shaft End Distance mm [in.]	V Keyway Length mm [in.]	R Keyway Height mm [in.]	I Key Width mm [in.]	H Pilot Diameter mm [in.]	J Output Body Diameter mm [in.]	G Pilot Length mm [in.]
XTA050	12 [0.47]	24.5 [0.97]	2 [0.079]	14 [0.55]	13.5 [0.53]	4 [0.16]	35 [1.38]	50 [1.97]	4 [0.16]
XTA070	16 [0.79]	36 [1.42]	2 [0.079]	25 [0.98]	18 [0.71]	5 [0.20]	52 [2.05]	70 [2.76]	5 [0.20]
XTA090	22 [0.87]	46 [1.81]	2 [0.079]	32 [1.26]	24.5 [0.96]	6 [0.24]	68 [2.68]	90 [3.54]	5 [0.20]
XTA120	32 [1.26]	70 [2.76]	4 [0.16]	50 [1.97]	35 [1.39]	10 [0.40]	90 [3.54]	120 [4.72]	6 [0.24]

### Dimensions

Part Number	D Output Housing Thread	E Thread Depth mm [in.]	O Output Shaft Thread mm [in.]	Q Thread Depth mm [in.]	F Square Size mm [in.]	K Output Body Length mm [in.]	L Length mm [in.]		C Bolt Circle mm [in.]
							3:1 - 10:1	15:1 - 100:1	
XTA050	M4x0.7-6H	8 [0.32]	M4x0.7-6H	8 [0.32]	42 [1.65]	11.7 [0.46]	33 [1.29]	46 [1.80]	44 [1.73]
XTA070	M5x0.8-6H	10 [0.40]	M5x0.8-6H	10 [0.40]	61 [2.40]	34.1 [1.34]	49 [1.93]	66.5 [2.62]	62 [2.44]
XTA090	M6x1.0-6H	12 [0.47]	M8x1.25-6H	13 [0.51]	90 [3.54]	24.5 [0.96]	65 [2.55]	87.5 [3.45]	80 [3.15]
XTA120	M8x1.25-6H	16 [0.63]	M12x1.75-6H	22 [0.87]	115 [4.53]	33.1 [1.30]	85.5 [3.36]	117 [4.60]	108 [4.25]

### Specifications

Part Number	Stages	Backlash (arc-min)	Efficiency	Weight		Ratio Availability
				kg	[lbs.]	
XTA050	1	13	93%	0.45	[1.0]	3:1, 4:1, 5:1, 7:1, 10:1
	2	15	88%	0.5	[1.1]	15:1, 20:1, 25:1, 30:1, 40:1, 50:1, 70:1, 100:1
XTA070	1	13	93%	1.0	[2.2]	3:1, 4:1, 5:1, 7:1, 10:1
	2	15	88%	1.2	[2.6]	15:1, 20:1, 25:1, 30:1, 40:1, 50:1, 70:1, 100:1
XTA090	1	13	93%	3.0	[6.6]	3:1, 4:1, 5:1, 7:1, 8:1, 10:1
	2	15	88%	3.7	[8.1]	15:1, 20:1, 25:1, 30:1, 40:1, 50:1, 70:1, 80:1, 100:1
XTA120	1	13	93%	5.7	[12.5]	3:1, 4:1, 5:1, 7:1, 10:1
	2	15	88%	7.3	[16.1]	15:1, 20:1, 25:1, 30:1, 40:1, 50:1, 70:1, 100:1

Specifications subject to change without notice.

# Micron TRUE Planetary® Gearheads

**XTRUE™**

True Planetary Gearheads

## Performance Specifications

Part Number	Ratio	20000 Hour Life				T <sub>peak</sub> Nm [in.-lb.]	J kg-cm <sup>2</sup> [in.-lb.-sec <sup>2</sup> *10 <sup>-4</sup> ]	Torsional Stiffness Nm/arc-min [in.-lb./arc-min]	
		T <sub>r</sub> (1000 rpm) Nm [in.-lb.]	T <sub>r</sub> (2000 rpm) Nm [in.-lb.]	T <sub>r</sub> (3000 rpm) Nm [in.-lb.]	T <sub>r</sub> (4000 rpm) Nm [in.-lb.]				
XT040	XT040-003	3:1	5.2 [46]	4.2 [37]	3.7 [33]	3.4 [30]	15.6 [138]	0.078 [0.690]	0.7 [6.2]
	XT040-004	4:1	5.54 [49]	4.41 [39]	3.95 [35]	3.62 [32]	16.5 [146]	0.057 [0.51]	0.7 [6.2]
	XT040-005	5:1	6.1 [54]	5.3 [47]	3.6 [32]	4.3 [38]	18.3 [162]	0.048 [0.425]	0.7 [6.2]
	XT040-007	7:1	6.1 [54]	4.97 [44]	4.41 [39]	4.07 [36]	18.3 [162]	0.042 [0.37]	0.7 [6.2]
	XT040-010	10:1	5.8 [51]	4.6 [41]	4.1 [36]	3.7 [33]	17.2 [152]	0.038 [0.336]	0.7 [6.2]
	XT040-015	15:1	8.4 [74]	6.8 [60]	6.0 [53]	5.5 [49]	25.2 [223]	0.045 [0.398]	0.7 [6.2]
	XT040-020	20:1	8.93 [79]	7.23 [64]	6.44 [57]	5.88 [52]	26.66 [236]	0.045 [0.398]	0.7 [6.2]
	XT040-025	25:1	9.3 [82]	7.6 [67]	6.7 [59]	6.1 [54]	27.8 [246]	0.045 [0.398]	0.7 [6.2]
	XT040-030	30:1	9.5 [84]	8.4 [74]	7.5 [66]	6.8 [60]	28.6 [253]	0.037 [0.328]	0.7 [6.2]
	XT040-040	40:1	10.96 [97]	8.93 [79]	7.91 [70]	7.23 [64]	32.88 [291]	0.037 [0.328]	0.7 [6.2]
	XT040-050	50:1	11.3 [100]	9.3 [82]	8.2 [73]	7.6 [67]	33.8 [299]	0.037 [0.328]	0.7 [6.2]
XTA050	XTA050-003	3:1	5.2 [46]	4.2 [37]	3.7 [33]	3.4 [30]	15.6 [138]	0.077 [0.682]	0.7 [6.2]
	XTA050-004	4:1	5.54 [49]	4.41 [39]	3.95 [35]	3.62 [32]	16.5 [146]	0.057 [0.50]	0.7 [6.2]
	XTA050-005	5:1	6.1 [54]	5.3 [47]	3.6 [32]	4.3 [38]	18.3 [162]	0.048 [0.425]	0.7 [6.2]
	XTA050-007	7:1	6.1 [54]	4.97 [44]	4.41 [39]	4.07 [36]	18.3 [162]	0.042 [0.37]	0.7 [6.2]
	XTA050-010	10:1	5.8 [51]	4.6 [41]	4.1 [36]	3.7 [33]	17.2 [152]	0.038 [0.336]	0.7 [6.2]
	XTA050-015	15:1	8.4 [74]	6.8 [60]	6.0 [53]	5.5 [49]	25.2 [223]	0.045 [0.398]	0.7 [6.2]
	XTA050-020	20:1	8.93 [79]	7.23 [64]	6.44 [57]	5.88 [52]	26.66 [236]	0.045 [0.398]	0.7 [6.2]
	XTA050-025	25:1	9.3 [82]	7.6 [67]	6.7 [59]	6.1 [54]	27.8 [246]	0.045 [0.398]	0.7 [6.2]
	XTA050-030	30:1	9.5 [84]	8.4 [74]	7.5 [66]	6.8 [60]	28.6 [253]	0.037 [0.328]	0.7 [6.2]
	XTA050-040	40:1	10.96 [97]	8.93 [79]	7.91 [70]	7.23 [64]	32.88 [291]	0.037 [0.328]	0.7 [6.2]
	XTA050-050	50:1	11.3 [100]	9.3 [82]	8.2 [73]	7.6 [67]	33.8 [299]	0.037 [0.328]	0.7 [6.2]
XT060	XT060-003	3:1	16 [139]	13 [112]	12 [102]	11 [93]	55 [483]	0.52 [4.6]	1.8 [15.9]
	XT060-004	4:1	20 [177]	17 [149]	15 [130]	14 [121]	46 [409]	0.46 [4.1]	1.8 [15.9]
	XT060-005	5:1	18 [158]	15 [130]	13 [112]	12 [102]	48 [427]	0.46 [4.1]	1.8 [15.9]
	XT060-007	7:1	17 [149]	14 [121]	12 [102]	11 [93]	43 [381]	0.46 [4.1]	1.8 [15.9]
	XT060-010	10:1	16 [139]	15 [130]	14 [121]	13 [112]	47 [418]	0.44 [3.9]	1.8 [15.9]
	XT060-015	15:1	26 [232]	21 [186]	19 [167]	17 [149]	55 [483]	0.46 [4.1]	1.8 [15.9]
	XT060-020	20:1	27 [242]	25 [223]	22 [195]	21 [186]	48 [427]	0.46 [4.1]	1.8 [15.9]
	XT060-025	25:1	25 [223]	23 [204]	20 [177]	19 [167]	55 [483]	0.46 [4.1]	1.8 [15.9]
	XT060-030	30:1	29 [260]	26 [232]	23 [204]	21 [186]	55 [483]	0.46 [4.1]	1.8 [15.9]
	XT060-040	40:1	28 [251]	27 [242]	27 [242]	25 [223]	48 [427]	0.44 [3.9]	1.8 [15.9]
	XT060-050	50:1	26 [232]	25 [223]	25 [223]	23 [204]	55 [483]	0.44 [3.9]	1.8 [15.9]
XT060	XT060-070	70:1	25 [223]	24 [214]	24 [214]	22 [195]	48 [427]	0.44 [3.9]	1.8 [15.9]
	XT060-100	100:1	21 [186]	20 [177]	19 [167]	18 [158]	43 [381]	0.44 [3.9]	1.8 [15.9]

All ratios in frame size 060, 070, 080, 090, 120 and 160 are available to ship in 24 hours through the Gearhead Express Program.

T<sub>r</sub> = Rated output torque at rated speed for specific hours of life.  
 T<sub>peak</sub> = Allowable momentary peak torque for emergency stop or heavy shock loading.  
 J = Mass moment of inertia reflected to the input shaft (including pinion assembly).  
 Specifications subject to change without notice.



### True Planetary Gearheads

#### Performance Specifications

Part Number	Ratio	20000 Hour Life				T <sub>peak</sub> Nm [in.-lb.]	J kg-cm <sup>2</sup> [in.-lb.-sec <sup>2</sup> *10 <sup>-4</sup> ]	Torsional Stiffness Nm/arc-min [in.-lb./arc-min]	
		T <sub>r</sub> (1000 rpm) Nm [in.-lb.]	T <sub>r</sub> (2000 rpm) Nm [in.-lb.]	T <sub>r</sub> (3000 rpm) Nm [in.-lb.]	T <sub>r</sub> (4000 rpm) Nm [in.-lb.]				
XTA070	XTA070-003	3:1	16 [139]	13 [112]	12 [102]	11 [93]	55 [483]	0.458 [4.054]	1.8 [15.9]
	XTA070-004	4:1	20 [177]	17 [149]	15 [130]	14 [121]	46 [409]	0.360 [3.168]	1.8 [15.9]
	XTA070-005	5:1	18 [158]	15 [130]	13 [112]	12 [102]	48 [427]	0.322 [2.850]	1.8 [15.9]
	XTA070-007	7:1	17 [149]	14 [121]	12 [102]	11 [93]	43 [381]	0.282 [2.496]	1.8 [15.9]
	XTA070-010	10:1	16 [139]	15 [130]	14 [121]	13 [112]	47 [418]	0.262 [2.319]	1.8 [15.9]
	XTA070-015	15:1	26 [232]	21 [186]	19 [167]	17 [149]	55 [483]	0.305 [2.699]	1.8 [15.9]
	XTA070-020	20:1	27 [242]	25 [223]	22 [195]	21 [186]	48 [427]	0.304 [2.691]	1.8 [15.9]
	XTA070-025	25:1	25 [223]	23 [204]	20 [177]	19 [167]	55 [483]	0.303 [2.682]	1.8 [15.9]
	XTA070-030	30:1	29 [260]	26 [232]	23 [204]	21 [186]	55 [483]	0.258 [2.283]	1.8 [15.9]
	XTA070-040	40:1	28 [251]	27 [242]	27 [242]	25 [223]	48 [427]	0.257 [2.275]	1.8 [15.9]
	XTA070-050	50:1	26 [232]	25 [223]	25 [223]	23 [204]	55 [483]	0.257 [2.275]	1.8 [15.9]
XTA070-070	70:1	25 [223]	24 [214]	24 [214]	22 [195]	48 [427]	0.257 [2.275]	1.8 [15.9]	
XTA070-100	100:1	21 [186]	20 [177]	19 [167]	18 [158]	43 [381]	0.257 [2.275]	1.8 [15.9]	
XT080	XT080-003	3:1	59 [520]	48 [427]	43 [381]	39 [344]	165 [1459]	2.2 [19.5]	5.4 [47.8]
	XT080-004	4:1	70 [623]	58 [511]	53 [465]	48 [427]	165 [1459]	1.8 [15.9]	5.4 [47.8]
	XT080-005	5:1	65 [576]	53 [465]	47 [418]	43 [381]	165 [1459]	1.8 [15.9]	5.4 [47.8]
	XT080-007	7:1	63 [558]	50 [446]	45 [400]	40 [353]	165 [1459]	1.7 [15.0]	5.4 [47.8]
	XT080-008	8:1	62 [549]	49 [434]	45 [398]	42 [372]	165 [1460]	1.6 [14.2]	5.4 [47.8]
	XT080-010	10:1	54 [474]	48 [427]	45 [400]	43 [381]	165 [1459]	1.8 [15.9]	5.4 [47.8]
	XT080-015	15:1	90 [799]	78 [688]	69 [613]	63 [558]	175 [1552]	1.8 [15.9]	5.4 [47.8]
	XT080-020	20:1	92 [818]	88 [781]	81 [716]	75 [660]	175 [1552]	1.5 [13.3]	5.4 [47.8]
	XT080-025	25:1	87 [771]	83 [734]	76 [669]	69 [613]	175 [1552]	1.7 [15.0]	5.4 [47.8]
	XT080-030	30:1	100 [883]	90 [799]	85 [753]	78 [688]	175 [1552]	1.7 [15.0]	5.4 [47.8]
	XT080-040	40:1	96 [846]	92 [818]	90 [799]	88 [781]	175 [1552]	1.6 [14.2]	5.4 [47.8]
XT080-050	50:1	90 [799]	87 [771]	85 [753]	83 [734]	175 [1552]	1.6 [14.2]	5.4 [47.8]	
XT080-070	70:1	88 [781]	85 [753]	83 [734]	82 [725]	175 [1552]	1.6 [14.2]	5.4 [47.8]	
XT080-080	80:1	84 [743]	80 [708]	78 [690]	74 [655]	175 [1549]	1.6 [14.2]	5.4 [47.8]	
XT080-100	100:1	72 [641]	67 [595]	63 [558]	61 [539]	175 [1552]	1.6 [14.2]	5.4 [47.8]	
XTA090	XTA090-003	3:1	59 [520]	48 [427]	43 [381]	39 [344]	165 [1459]	2.065 [18.277]	5.4 [47.8]
	XTA090-004	4:1	70 [623]	58 [511]	53 [465]	48 [427]	165 [1459]	1.621 [14.347]	5.4 [47.8]
	XTA090-005	5:1	65 [576]	53 [465]	47 [418]	43 [381]	165 [1459]	1.400 [12.391]	5.4 [47.8]
	XTA090-007	7:1	63 [558]	50 [446]	45 [400]	40 [353]	165 [1459]	1.193 [10.559]	5.4 [47.8]
	XTA090-008	8:1	62 [549]	49 [434]	45 [398]	42 [372]	165 [1460]	1.156 [10.231]	5.4 [47.8]
	XTA090-010	10:1	54 [474]	48 [427]	45 [400]	43 [381]	165 [1459]	1.118 [9.895]	5.4 [47.8]
	XTA090-015	15:1	90 [799]	78 [688]	69 [613]	63 [558]	175 [1552]	1.329 [11.763]	5.4 [47.8]
	XTA090-020	20:1	92 [818]	88 [781]	81 [716]	75 [660]	175 [1552]	1.319 [11.674]	5.4 [47.8]
	XTA090-025	25:1	87 [771]	83 [734]	76 [669]	69 [613]	175 [1552]	1.319 [11.674]	5.4 [47.8]
	XTA090-030	30:1	100 [883]	90 [799]	85 [753]	78 [688]	175 [1552]	1.100 [9.736]	5.4 [47.8]
	XTA090-040	40:1	96 [846]	92 [818]	90 [799]	88 [781]	175 [1552]	1.235 [10.931]	5.4 [47.8]
XTA090-050	50:1	90 [799]	87 [771]	85 [753]	83 [734]	175 [1552]	1.097 [9.709]	5.4 [47.8]	
XTA090-070	70:1	88 [781]	85 [753]	83 [734]	82 [725]	175 [1552]	1.096 [9.700]	5.4 [47.8]	
XTA090-080	80:1	84 [743]	80 [708]	78 [690]	74 [655]	175 [1549]	1.096 [9.700]	5.4 [47.8]	
XTA090-100	100:1	72 [641]	67 [595]	63 [558]	61 [539]	175 [1552]	1.095 [9.692]	5.4 [47.8]	

All ratios in frame size 060, 070, 080, 090, 120 and 160 are available to ship in 24 hours through the Gearhead Express Program.

T<sub>r</sub> = Rated output torque at rated speed for specific hours of life.

T<sub>peak</sub> = Allowable momentary peak torque for emergency stop or heavy shock loading.

J = Mass moment of inertia reflected to the input shaft (including pinion assembly).

Specifications subject to change without notice.

# Micron TRUE Planetary® Gearheads

## XTRUE™

### True Planetary Gearheads

#### Performance Specifications

Part Number	Ratio	20000 Hour Life				T <sub>peak</sub> Nm [in.-lb.]	J kg-cm <sup>2</sup> [in.-lb.-sec <sup>2</sup> *10 <sup>-4</sup> ]	Torsional Stiffness Nm/arc-min [in.-lb./arc-min]	
		T <sub>r</sub> (1000 rpm) Nm [in.-lb.]	T <sub>r</sub> (2000 rpm) Nm [in.-lb.]	T <sub>r</sub> (3000 rpm) Nm [in.-lb.]	T <sub>r</sub> (4000 rpm) Nm [in.-lb.]				
XT120 / XTA120	XT(A)120-003	3:1	90 [799]	74 [650]	65 [576]	59 [520]	298 [2639]	7.695 [68.107]	17.4 [154.0]
	XT(A)120-004	4:1	107 [948]	89 [790]	79 [697]	74 [650]	298 [2639]	5.949 [52.653]	17.4 [154.0]
	XT(A)120-005	5:1	99 [873]	81 [716]	71 [632]	65 [576]	298 [2639]	5.149 [45.573]	17.4 [154.0]
	XT(A)120-007	7:1	97 [855]	79 [697]	68 [604]	63 [558]	298 [2639]	4.413 [39.058]	17.4 [154.0]
	XT(A)120-010	10:1	87 [771]	79 [697]	74 [650]	69 [613]	298 [2639]	4.048 [35.828]	17.4 [154.0]
	XT(A)120-015	15:1	146 [1292]	119 [1050]	105 [929]	96 [846]	298 [2639]	4.748 [42.023]	17.4 [154.0]
	XT(A)120-020	20:1	169 [1496]	139 [1227]	124 [1097]	114 [1013]	298 [2639]	4.709 [41.678]	17.4 [154.0]
	XT(A)120-025	25:1	161 [1422]	130 [1152]	116 [1022]	106 [939]	298 [2639]	4.690 [41.510]	17.4 [154.0]
	XT(A)120-030	30:1	180 [1589]	146 [1292]	129 [1143]	119 [1050]	298 [2639]	3.949 [34.952]	17.4 [154.0]
	XT(A)120-040	40:1	187 [1654]	169 [1496]	150 [1329]	139 [1227]	298 [2639]	3.938 [34.854]	17.4 [154.0]
	XT(A)120-050	50:1	179 [1580]	161 [1422]	142 [1254]	130 [1152]	298 [2639]	3.933 [34.810]	17.4 [154.0]
XT(A)120-070	70:1	176 [1561]	159 [1403]	140 [1236]	128 [1134]	298 [2639]	3.929 [34.775]	17.4 [154.0]	
XT(A)120-100	100:1	120 [1059]	109 [966]	104 [920]	100 [883]	298 [2639]	3.927 [34.757]	17.4 [154.0]	
XT160	XT160-003	3:1	317 [2806]	257 [2277]	228 [2016]	209 [1849]	876 [7750]	23 [204]	50.5 [446.9]
	XT160-004	4:1	371 [3280]	305 [2695]	272 [2407]	251 [2221]	876 [7750]	15 [133]	50.5 [446.9]
	XT160-005	5:1	350 [3094]	284 [2509]	251 [2221]	230 [2035]	876 [7750]	14 [124]	50.5 [446.9]
	XT160-007	7:1	344 [3048]	278 [2463]	246 [2174]	225 [1989]	876 [7750]	15 [133]	50.5 [446.9]
	XT160-010	10:1	222 [1961]	198 [1756]	185 [1635]	175 [1552]	876 [7750]	12 [106]	50.5 [446.9]
	XT160-015	15:1	508 [4498]	417 [3689]	370 [3271]	339 [3001]	876 [7750]	15 [133]	50.5 [446.9]
	XT160-020	20:1	513 [4544]	481 [4256]	428 [3791]	395 [3494]	876 [7750]	15 [133]	50.5 [446.9]
	XT160-025	25:1	492 [4358]	460 [4070]	407 [3605]	374 [3308]	876 [7750]	15 [133]	50.5 [446.9]
	XT160-030	30:1	562 [4971]	508 [4498]	455 [4024]	417 [3689]	876 [7750]	12 [106]	50.5 [446.9]
	XT160-040	40:1	536 [4739]	513 [4544]	500 [4423]	481 [4256]	876 [7750]	13 [115]	50.5 [446.9]
	XT160-050	50:1	515 [4553]	492 [4358]	479 [4237]	460 [4070]	876 [7750]	12 [106]	50.5 [446.9]
	XT160-070	70:1	509 [4507]	487 [4312]	474 [4191]	455 [4024]	876 [7750]	12 [106]	50.5 [446.9]
	XT160-100	100:1	306 [2704]	279 [2472]	265 [2342]	254 [2249]	876 [7750]	12 [106]	50.5 [446.9]

All ratios in frame size 060, 070, 080, 090, 120 and 160 are available to ship in 24 hours through the Gearhead Express Program.

T<sub>r</sub> = Rated output torque at rated speed for specific hours of life.

T<sub>peak</sub> = Allowable momentary peak torque for emergency stop or heavy shock loading.

J = Mass moment of inertia reflected to the input shaft (including pinion assembly).

Specifications subject to change without notice.

### True Planetary Gearheads

## Radial and Axial Load Ratings

### XT040 / XTA050

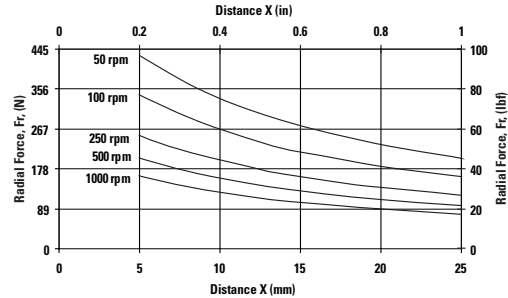
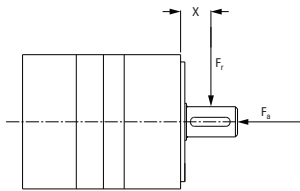

Speed rpm	Axial Load, $F_a$ N [lb.]
50	737 [166]
100	585 [132]
250	431 [97]
500	342 [77]
1000	272 [61]

### XT060 / XTA070

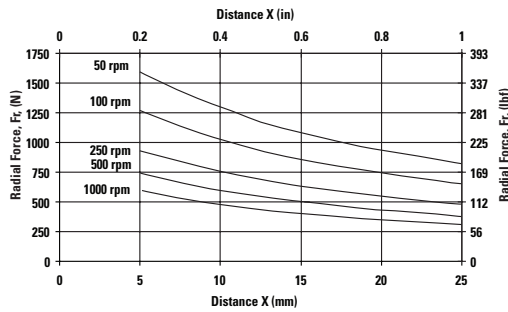
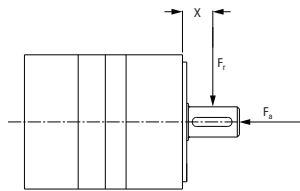

Speed rpm	Axial Load, $F_a$ N [lb.]
50	2542 [571]
100	2017 [454]
250	1486 [334]
500	1180 [265]
1000	936 [211]

### XT080 / XTA090

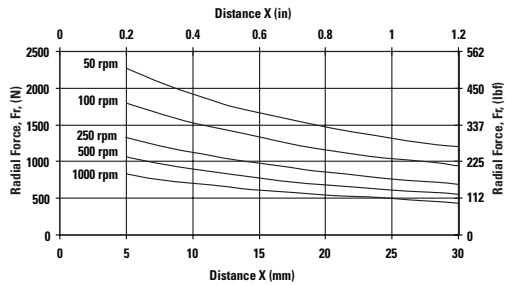
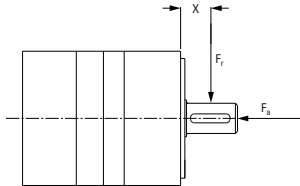

Speed rpm	Axial Load, $F_a$ N [lb.]
50	3780 [850]
100	3000 [675]
250	2211 [497]
500	1755 [394]
1000	1393 [313]

### XT120 / XTA120

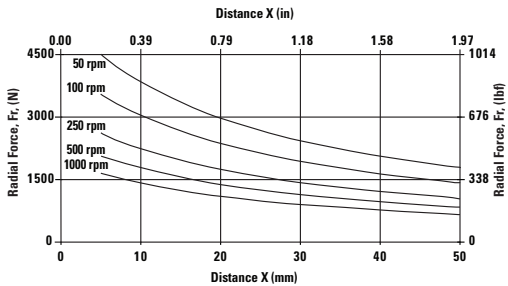
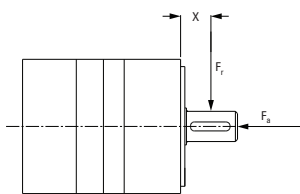

Speed rpm	Axial Load, $F_a$ N [lb.]
50	6894 [1550]
100	5471 [1230]
250	4034 [907]
500	3203 [720]
1000	2540 [571]

### XT160

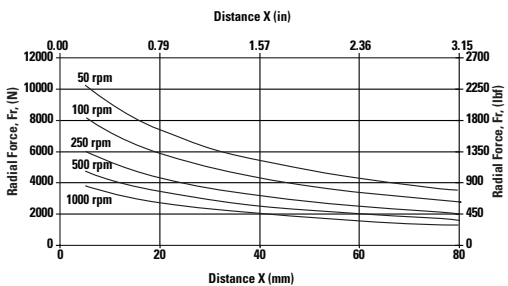
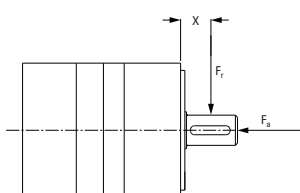

Speed rpm	Axial Load, $F_a$ N [lb.]
50	14,122 [3175]
100	11,209 [2520]
250	8260 [1857]
500	6556 [1474]
1000	5204 [1170]

These graphs display the allowable radial load at a given distance (X) from the mounting surface based on an  $L_{10}$  life of 20,000 hours for the mean output speed.

# Micron TRUE Planetary® Gearheads

## NemaTRUE™

### True Planetary Gearheads

Ready for Immediate Delivery	
Precision	13 arc-minutes
Frame Sizes	17, 23/60 mm, 34/90 mm and 42/115 mm
Torque Capacity	up to 180 Nm
Ratio Availability	3:1 thru 100:1
Radial load capacity	up to 3730 N
Mounting System	RediMount™

- 1 Sealed deep groove ball bearings**  
provide high radial load carrying capability
- 2 HRC 55-60 steel gears**  
provide superior wear resistance  
and increased backlash integrity
- 3 Sealed deep groove ball bearing**  
provides precision alignment of sun gear
- 4 RediMount system**  
provides error-free motor installation
- 5 Anodized aluminum housing**  
reduces weight and prevents corrosion

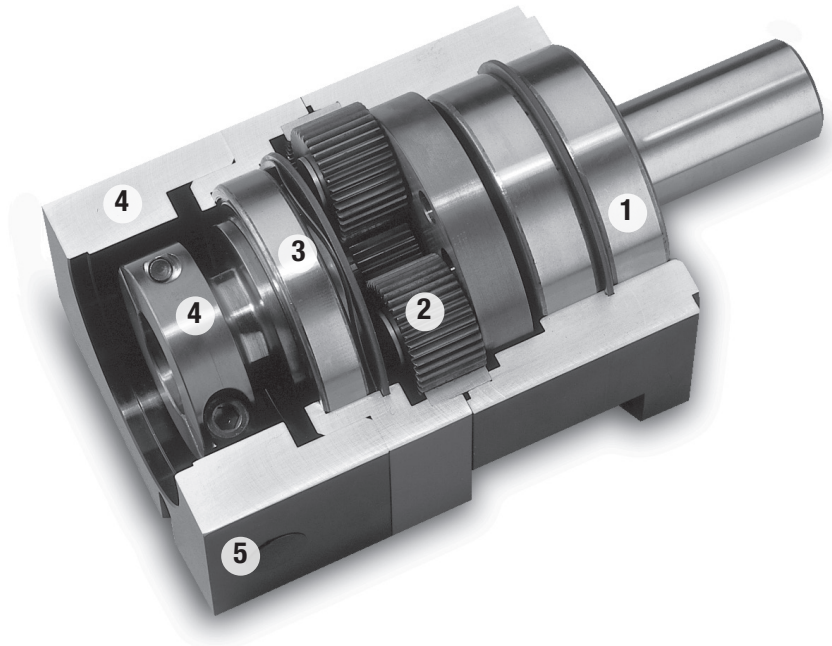

**Micron True Planetary® Gearheads  
shipped within 24 hours!**

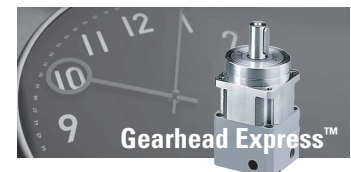

**Need it fast? Go to the back cover  
of the catalog for details.**

### True Planetary Gearheads

English

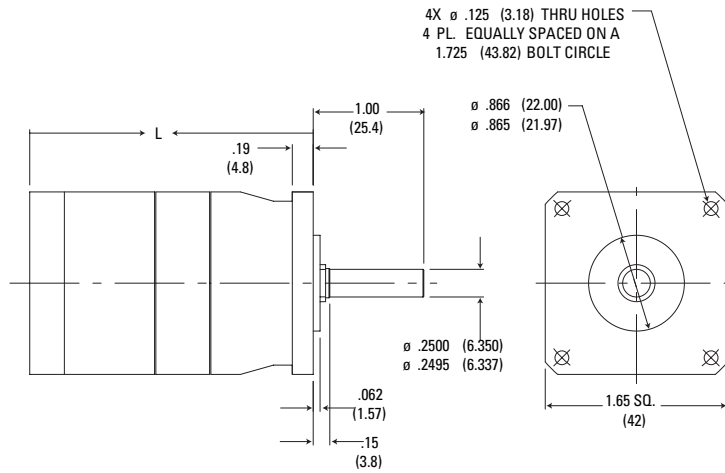

Ratio <sup>1</sup>	Dimension 'L' in. [mm]	Backlash [arc-min]	Weight lb. [kg]	Efficiency
3:1 to 10:1	2.28 [58]	13 max	.75 [0,34]	93%
15:1 to 100:1	2.77 [71]	15 max	.95 [0,43]	88%

Dimensions are inch (mm)  
Efficiency is calculated at 100% of the rated torque.  
Total length may change depending on motor being used.

## Performance Specifications

Part Number	Ratio <sup>1</sup>	20000 Hour Life				T <sub>peak</sub> in.-lb. [Nm]	J in.-lb.-sec <sup>2</sup> ×10 <sup>-4</sup> [kg-cm <sup>2</sup> ]	Torsional Stiffness in.-lb./arc-min [Nm/arc-min]
		T <sub>r</sub> (1000 rpm) in.-lb. [Nm]	T <sub>r</sub> (2000 rpm) in.-lb. [Nm]	T <sub>r</sub> (3000 rpm) in.-lb. [Nm]	T <sub>r</sub> (4000 rpm) in.-lb. [Nm]			
NT17-003	3:1	41 [4,7]	34 [3,8]	29 [3,3]	27 [3,1]	170 [19,2]	0.115 [0,013]	2.36 [0,268]
NT17-005	5:1	44 [5,0]	37 [4,2]	33 [3,7]	30 [3,4]	170 [19,2]	0.040 [0,005]	2.36 [0,268]
NT17-010	10:1	30 [3,4]	28 [3,1]	25 [2,8]	23 [2,6]	170 [19,2]	0.030 [0,003]	2.36 [0,268]
NT17-015	15:1	47 [5,3]	47 [5,3]	47 [5,3]	42 [4,7]	170 [19,2]	0.037 [0,004]	2.36 [0,268]
NT17-025	25:1	78 [8,8]	58 [6,6]	53 [6,0]	48 [5,5]	170 [19,2]	0.037 [0,004]	2.36 [0,268]
NT17-030	30:1	57 [6,4]	52 [5,9]	48 [5,4]	46 [5,2]	170 [19,2]	0.026 [0,003]	2.36 [0,268]
NT17-050	50:1	91 [10,3]	78 [8,8]	65 [7,4]	60 [6,7]	170 [19,2]	0.026 [0,003]	2.36 [0,268]
NT17-100	100:1	40 [4,5]	38 [4,3]	35 [4,0]	33 [3,8]	170 [19,2]	0.026 [0,003]	2.36 [0,268]

<sup>1</sup> Ratios are exact, higher ratios and other custom options are also available, consult factory.  
T<sub>r</sub> = Rated output torque at rated speed for specific hours of life.

T<sub>peak</sub> = Allowable momentary peak torque for emergency stop or heavy shock loading.  
J = Mass moment of inertia reflected to the input shaft (including pinion assembly).

# Micron TRUE Planetary® Gearheads

## NemaTRUE™ Size 23/60

### True Planetary Gearheads

English

English - Dimensions are in. (mm)

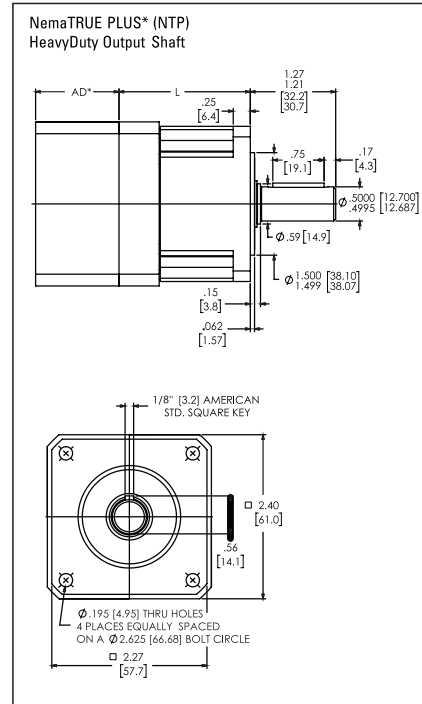
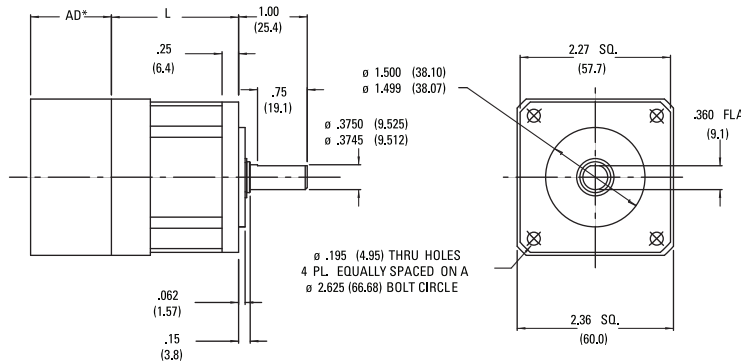

Metric - Dimensions are mm (in)

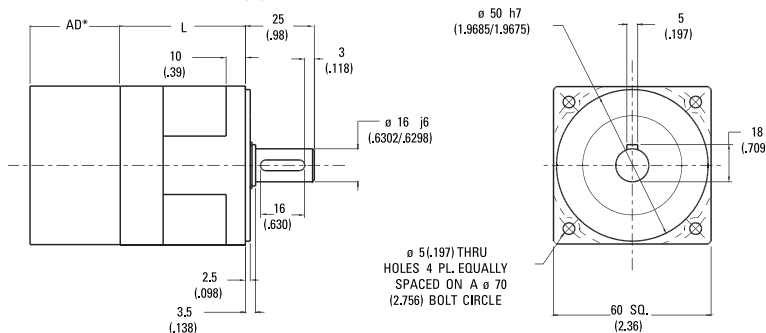

Ratio <sup>1</sup>	NT23 Dimension 'L' in. [mm]	NT60 Dimension 'L' in. [mm]	Backlash [arc-min]		Weight lb. [kg]	Efficiency
			Precision	High Precision		
3:1 to 10:1	1.92 [48,8]	2.07 [52,6]	13 max	8 max	1.5 [0,7]	93%
15:1 to 100:1	2.61 [66,3]	2.76 [70,1]	15 max	9 max	1.9 [0,9]	88%

AD\*\* = Adapter length  
Adapter length will vary depending on motor.  
Efficiency is calculated at 100% of the rated torque.

## Performance Specifications

Part Number		Ratio <sup>1</sup>	20000 Hour Life				T <sub>peak</sub> in.-lb. [Nm]	J in.-lb.-sec <sup>2</sup> x10 <sup>-4</sup> [kg-cm <sup>2</sup> ]	Torsional Stiffness in.-lb./arc-min [Nm/arc-min]	
English	Metric		T <sub>r</sub> (1000 rpm) in.-lb. [Nm]	T <sub>r</sub> (2000 rpm) in.-lb. [Nm]	T <sub>r</sub> (3000 rpm) in.-lb. [Nm]	T <sub>r</sub> (4000 rpm) in.-lb. [Nm]			NT	NTP
NT23-003	NT60-003	3:1	98 [11,1]	80 [9,0]	70 [7,9]	65 [7,3]	150 [16,9]	0.67 [0,076]	6.3 [0,71]	15.8 [1,8]
NT23-004	NT60-004	4:1	107 [12,1]	90 [10,2]	80 [9,0]	73 [8,2]	250 [28,3]	0.22 [0,024]	6.3 [0,71]	15.8 [1,8]
NT23-005	NT60-005	5:1	105 [11,9]	88 [9,9]	78 [8,8]	71 [8,0]	250 [28,2]	0.22 [0,025]	6.3 [0,71]	15.8 [1,8]
NT23-007	NT60-007	7:1	100 [11,3]	83 [9,4]	74 [8,4]	66 [7,5]	250 [28,3]	0.22 [0,024]	6.3 [0,71]	15.8 [1,8]
NT23-010	NT60-010	10:1	163 [7,1]	58 [6,6]	54 [6,1]	52 [5,9]	250 [28,2]	0.14 [0,016]	6.3 [0,71]	15.8 [1,8]
NT23-015	NT60-015	15:1	124 [14,0]	110 [12,4]	105 [11,9]	100 [11,3]	250 [28,3]	0.21 [0,024]	6.3 [0,71]	15.8 [1,8]
NT23-020	NT60-020	20:1	180 [20,3]	147 [16,6]	130 [14,7]	120 [13,6]	275 [31,1]	0.21 [0,024]	6.3 [0,71]	15.8 [1,8]
NT23-025	NT60-025	25:1	175 [9,8]	142 [16,0]	125 [14,1]	115 [13,0]	250 [28,3]	0.21 [0,024]	6.3 [0,71]	15.8 [1,8]
NT23-030	NT60-030	30:1	207 [23,4]	182 [20,6]	157 [17,7]	147 [16,6]	275 [31,1]	0.13 [0,015]	6.3 [0,71]	15.8 [1,8]
NT23-040	NT60-040	40:1	207 [23,4]	182 [20,6]	157 [17,7]	147 [16,6]	275 [31,1]	0.13 [0,015]	6.3 [0,71]	15.8 [1,8]
NT23-050	NT60-050	50:1	202 [22,8]	175 [19,8]	152 [17,2]	142 [16,0]	275 [31,1]	0.13 [0,015]	6.3 [0,71]	15.8 [1,8]
NT23-070	NT60-070	70:1	197 [22,3]	172 [19,4]	147 [16,6]	137 [15,5]	275 [31,1]	0.13 [0,015]	6.3 [0,71]	15.8 [1,8]
NT23-100	NT60-100	100:1	85 [9,6]	79 [8,9]	74 [8,9]	73 [8,2]	275 [31,1]	0.13 [0,015]	6.3 [0,71]	15.8 [1,8]

All ratios are available to ship in 24 hours through the Gearhead Express Program.

<sup>1</sup> Ratios are exact, higher ratios and other custom options are also available, consult factory.

T<sub>r</sub> = Rated output torque at rated speed for specific hours of life.

T<sub>peak</sub> = Allowable momentary peak torque for emergency stop or heavy shock loading.

J = Mass moment of inertia reflected to the input shaft (including pinion assembly).

# Micron TRUE Planetary® Gearheads

## NemaTRUE Size 34/90

### True Planetary Gearheads

### English

English - Dimensions are in. (mm)

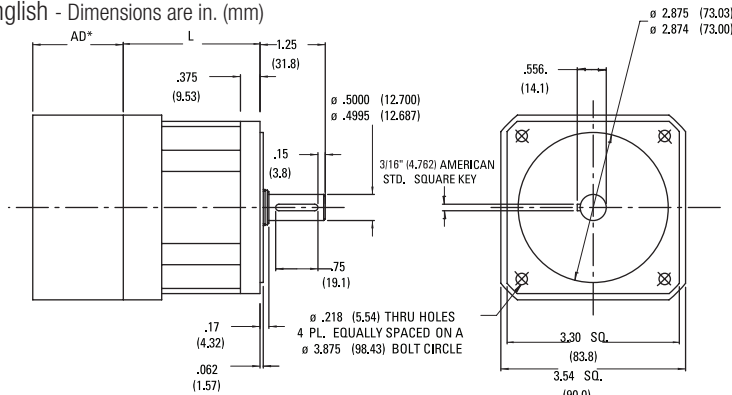

Metric - Dimensions are mm (in)

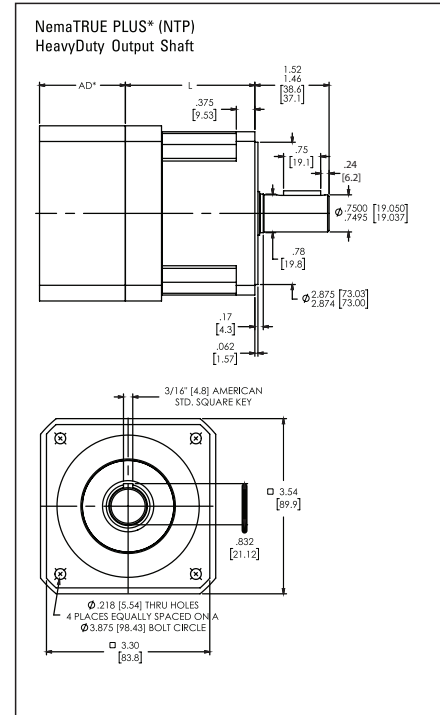
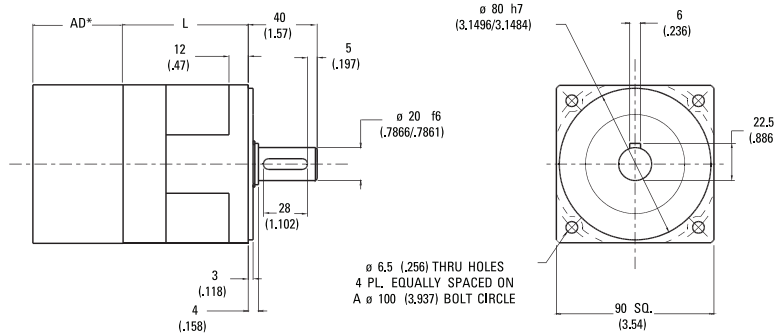

Ratio <sup>1</sup>	NT34 Dimension 'L' in. [mm]	NT90 Dimension 'L' in. [mm]	Backlash [arc-min]		Weight lb. [kg]	Efficiency
			Precision	High Precision		
3:1 to 10:1	2.62 [66,4]	2.63 [66,8]	13 max	8 max	4.2 [1,9]	93%
15:1 to 100:1	3.53 [89,6]	3.53 [89,7]	15 max	9 max	5.6 [2,5]	88%

AD\*\* = Adapter length  
Adapter length will vary depending on motor.  
Efficiency is calculated at 100% of the rated torque.

## Performance Specifications

Part Number		Ratio <sup>1</sup>	20000 Hour Life				T <sub>peak</sub> in.-lb. [Nm]	J in.-lb.-sec <sup>2</sup> ×10 <sup>-4</sup> [kg-cm <sup>2</sup> ]	Torsional Stiffness in.-lb./arc-min [Nm/arc-min]	
English	Metric		T <sub>r</sub> (1000 rpm) in.-lb. [Nm]	T <sub>r</sub> (2000 rpm) in.-lb. [Nm]	T <sub>r</sub> (3000 rpm) in.-lb. [Nm]	T <sub>r</sub> (4000 rpm) in.-lb. [Nm]			NT	NTP
NT34-003	NT90-003		3:1	360 [40,7]	320 [36,2]	295 [33,3]			270 [30,5]	510 [57,6]
NT34-004	NT90-004	4:1	515 [58,2]	425 [48,0]	380 [42,9]	350 [39,6]	700 [79,1]	1.20 [0,140]	16.8 [1,9]	48 [5,4]
NT34-005	NT90-005	5:1	490 [55,4]	400 [45,2]	355 [40,1]	325 [36,7]	700 [79,1]	1.20 [0,140]	16.8 [1,9]	48 [5,4]
NT34-007	NT90-007	7:1	470 [53,1]	380 [42,9]	335 [37,9]	305 [34,5]	700 [79,1]	1.20 [0,140]	16.8 [1,9]	48 [5,4]
NT34-010	NT90-010	10:1	238 [26,9]	212 [24,0]	200 [22,6]	192 [21,7]	700 [79,1]	0.66 [0,075]	16.8 [1,9]	48 [5,4]
NT34-015	NT90-015	15:1	454 [51,3]	416 [47,0]	391 [44,2]	373 [42,1]	850 [96,0]	1.20 [0,140]	16.8 [1,9]	48 [5,4]
NT34-020	NT90-020	20:1	677 [76,5]	620 [70,1]	587 [66,3]	551 [62,3]	850 [96,1]	1.20 [0,140]	16.8 [1,9]	48 [5,4]
NT34-025	NT90-025	25:1	652 [73,7]	595 [67,2]	562 [63,5]	526 [59,4]	850 [96,0]	1.20 [0,140]	16.8 [1,9]	48 [5,4]
NT34-030	NT90-030	30:1	500 [56,5]	454 [51,3]	432 [48,8]	416 [47,0]	850 [96,0]	0.66 [0,075]	16.8 [1,9]	48 [5,4]
NT34-040	NT90-040	40:1	770 [87,0]	702 [79,3]	668 [75,5]	620 [70,1]	850 [96,1]	0.65 [0,074]	16.8 [1,9]	48 [5,4]
NT34-050	NT90-050	50:1	720 [81,4]	652 [73,7]	618 [69,8]	595 [67,2]	850 [96,0]	0.65 [0,074]	16.8 [1,9]	48 [5,4]
NT34-070	NT90-070	70:1	770 [87,0]	702 [79,3]	668 [75,5]	620 [70,1]	850 [96,1]	0.65 [0,074]	16.8 [1,9]	48 [5,4]
NT34-100	NT90-100	100:1	325 [36,7]	295 [33,3]	280 [31,6]	270 [30,5]	700 [79,1]	0.65 [0,074]	16.8 [1,9]	48 [5,4]

All ratios are available to ship in 24 hours through the Gearhead Express Program.

<sup>1</sup> Ratios are exact, higher ratios and other custom options are also available, consult factory.

T<sub>r</sub> = Rated output torque at rated speed for specific hours of life.

T<sub>peak</sub> = Allowable momentary peak torque for emergency stop or heavy shock loading.

J = Mass moment of inertia reflected to the input shaft (including pinion assembly).

# Micron TRUE Planetary® Gearheads

## NemaTRUE™ Size 42/115

### True Planetary Gearheads

English

English - Dimensions are in. (mm)

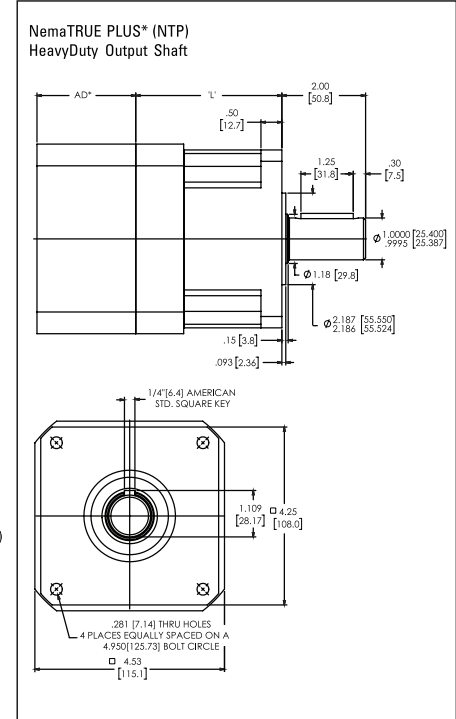
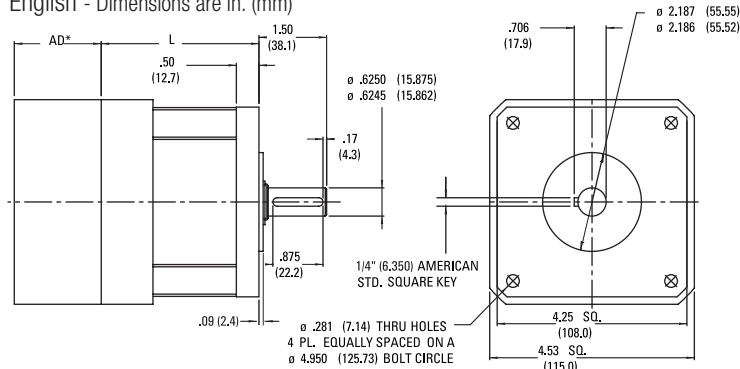

Metric - Dimensions are mm (in)

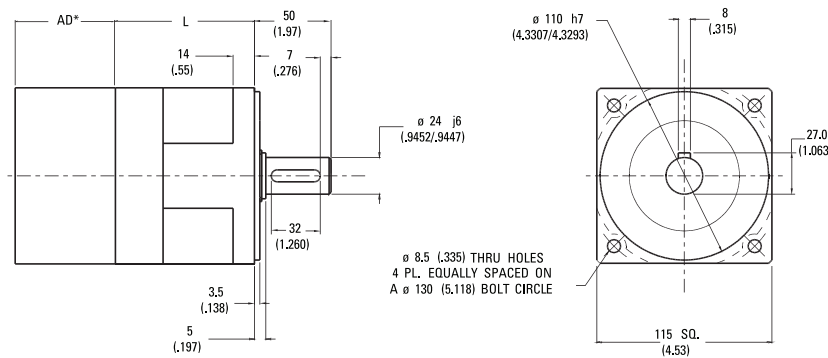

Ratio <sup>1</sup>	NT42	NT115	Backlash [arc-min]		Weight lb. [kg]	Efficiency
	Dimension 'L' in. [mm]	Dimension 'L' in. [mm]	Precision	High Precision		
3:1 to 10:1	3.49 [88.7]	3.46 [87.9]	13 max	8 max	8.9 [4.0]	93%
15:1 to 100:1	4.72 [120.0]	4.69 [119.1]	15 max	9 max	11.7 [5.3]	88%

AD\*\* = Adapter length  
 Adapter length will vary depending on motor.  
 Efficiency is calculated at 100% of the rated torque.

## Performance Specifications

Part Number		Ratio <sup>1</sup>	20000 Hour Life				T <sub>peak</sub> in.-lb. [Nm]	J in.-lb.-sec <sup>2</sup> x10 <sup>-4</sup> [kg-cm <sup>2</sup> ]	Torsional Stiffness in.-lb./arc-min [Nm/arc-min]	
English	Metric		T <sub>r</sub> (1000 rpm) in.-lb. [Nm]	T <sub>r</sub> (2000 rpm) in.-lb. [Nm]	T <sub>r</sub> (3000 rpm) in.-lb. [Nm]	T <sub>r</sub> (4000 rpm) in.-lb. [Nm]			NT	NTP
NT42-003	NT115-003		3:1	690 [78.0]	594 [67.1]	530 [59.9]			485 [54.8]	1000 [113.0]
NT42-004	NT115-004	4:1	850 [96.1]	698 [78.9]	622 [70.3]	570 [64.4]	1000 [113.0]	3.80 [0.43]	31 [3.5]	154 [17.4]
NT42-005	NT115-005	5:1	810 [55.4]	400 [45.2]	355 [40.1]	325 [36.7]	1000 [113.0]	3.80 [0.43]	31 [3.5]	154 [17.4]
NT42-007	NT115-007	7:1	790 [89.3]	638 [72.1]	562 [63.5]	510 [57.6]	1000 [113.0]	3.80 [0.43]	31 [3.5]	154 [17.4]
NT42-010	NT115-010	10:1	460 [52.0]	412 [46.6]	388 [43.8]	370 [41.8]	1000 [113.0]	1.9 [0.21]	31 [3.5]	154 [17.4]
NT42-015	NT115-015	15:1	454 [51.3]	416 [47.0]	391 [44.2]	373 [42.1]	1600 [180.8]	3.9 [0.44]	31 [3.5]	154 [17.4]
NT42-020	NT115-020	20:1	1290 [145.8]	1090 [123.2]	985 [111.3]	905 [102.3]	1600 [180.8]	3.70 [0.42]	31 [3.5]	154 [17.4]
NT42-025	NT115-025	25:1	1250 [141.2]	1050 [118.6]	945 [106.8]	865 [97.7]	1600 [180.8]	3.70 [0.42]	31 [3.5]	154 [17.4]
NT42-030	NT115-030	30:1	972 [109.8]	878 [99.2]	842 [95.1]	805 [91.0]	1600 [180.8]	1.9 [0.21]	31 [3.5]	154 [17.4]
NT42-040	NT115-040	40:1	1435 [162.2]	1290 [145.8]	1190 [134.5]	1090 [123.2]	1600 [180.8]	1.80 [0.20]	31 [3.5]	154 [17.4]
NT42-050	NT115-050	50:1	1395 [157.6]	1250 [141.2]	1150 [118.6]	1050 [118.6]	1600 [180.8]	1.80 [0.20]	31 [3.5]	154 [17.4]
NT42-070	NT115-070	70:1	1375 [155.4]	1230 [139.0]	1130 [127.7]	1030 [116.4]	1600 [180.8]	1.80 [0.20]	31 [3.5]	154 [17.4]
NT42-100	NT115-100	100:1	630 [71.2]	575 [65.0]	540 [61.0]	522 [59.0]	1200 [135.6]	1.80 [0.20]	31 [3.5]	154 [17.4]

All ratios are available to ship in 24 hours through the Gearhead Express Program.

<sup>1</sup> Ratios are exact, higher ratios and other custom options are also available, consult factory.

T<sub>r</sub> = Rated output torque at rated speed for specific hours of life.

T<sub>peak</sub> = Allowable momentary peak torque for emergency stop or heavy shock loading.

J = Mass moment of inertia reflected to the input shaft (including pinion assembly).



## Radial and Axial Load Ratings

### NT17

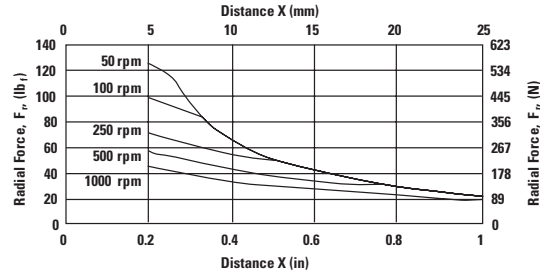
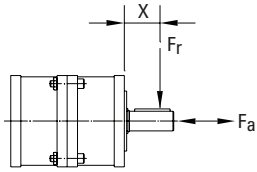

Speed	Axial Load, $F_a$
rpm	lb <sub>r</sub> [N]
250	138 [614]

### NT23, NTP23, NT60

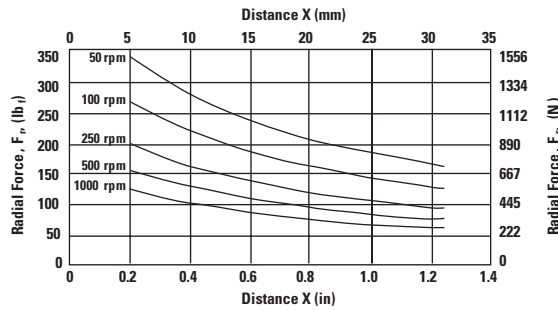
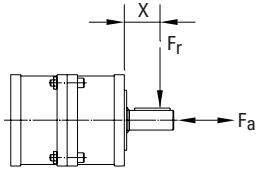

Speed	Axial Load, $F_a$
rpm	lb <sub>r</sub> [N]
250	310 [1379]

### NT34, NTP34, NT90

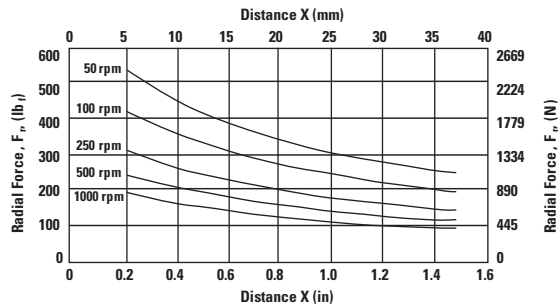
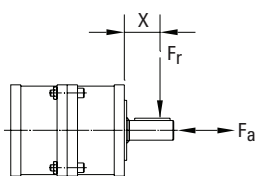

Speed	Axial Load, $F_a$
rpm	lb <sub>r</sub> [N]
250	510 [2269]

### NT42, NTP42, NT115

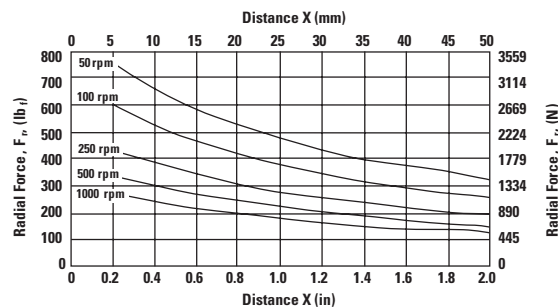
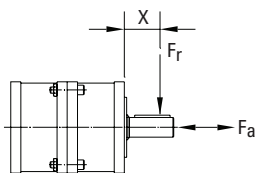

Speed	Axial Load, $F_a$
rpm	lb <sub>r</sub> [N]
250	760 [3380]

These graphs display the allowable radial load at a given distance (X) from the mounting surface based on an L<sub>10</sub> life of 10,000 hours for the mean output speed  $n_{mout}$ , as described on page 9.

# Micron TRUE Planetary® Gearheads

## NemaTRUE™ 90

### Right Angle Gearheads

Ready for Immediate Delivery	
Precision	13 arc-minutes
Frame Sizes	NEMA 23, 34, 42
Torque Capacity	up to 255 Nm
Ratio Availability	1:1 thru 500:1
Radial load capacity	up to 2900 N
Mounting System	RediMount™

- 1 Tapered roller bearings**  
provide high radial and axial load capacity
- 2 Innovative PowerTRUE gearing**  
delivers smooth, quiet geared reduction
- 3 Tapered roller bearings**  
provide high axial load carrying capabilities
- 4 HRC 55-60 steel gears**  
provide superior wear resistance and increased backlash integrity
- 5 RediMount system**  
provides error-free motor installation

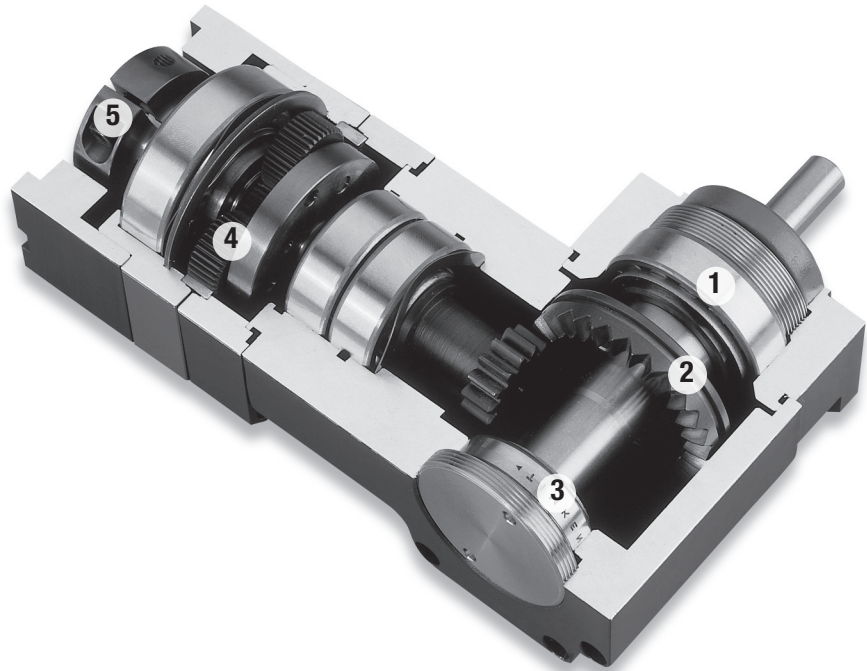

**Micron True Planetary® Gearheads  
shipped within 24 hours!**

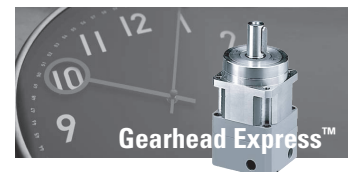

**Need it fast? Go to the back cover  
of the catalog for details.**

### Right Angle Gearheads

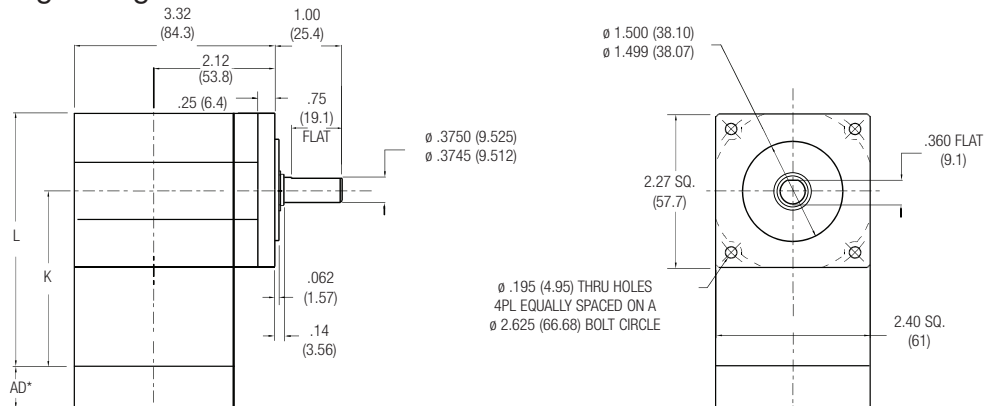

Ratio <sup>1</sup>	Dimension 'K' in. [mm]	Dimension 'L' in. [mm]	Backlash [arc-min]	Weight lb. [kg]	Efficiency
1:1 to 5:1P	3.11 [79]	4.31 [109,5]	13 max	3.0 [1,4]	98%
5:1T to 50:1	3.79 [96]	4.99 [127]	15 max	3.4 [1,5]	93%
60:1 to 500:1	4.48 [114]	5.68 [144]	15 max	3.8 [1,6]	88%

Dimensions are in. (mm)  
AD\*\* = Adapter length  
Adapter length will vary depending on motor.  
Efficiency is calculated at 100% of the rated torque.

### Performance Specifications

Part Number	Ratio <sup>1</sup>	10000 Hour Life			T <sub>peak</sub> in.-lb. [Nm]	20000 Hour Life			J in.-lb.-sec <sup>2</sup> x10 <sup>-4</sup> [kg-cm <sup>2</sup> ]	Torsional Stiffness in.-lb./arc-min [Nm/arc-min]
		T <sub>r</sub> (1000 rpm) in.-lb. [Nm]	T <sub>r</sub> (3000 rpm) in.-lb. [Nm]	T <sub>r</sub> (5000 rpm) in.-lb. [Nm]		T <sub>r</sub> (1000 rpm) in.-lb. [Nm]	T <sub>r</sub> (3000 rpm) in.-lb. [Nm]	T <sub>r</sub> (5000 rpm) in.-lb. [Nm]		
NTR23-001	1:1	59 [7]	54 [6]	49 [6]	195 [22]	54 [6]	50 [6]	45 [5]	7.01 [0,79]	5.6 [0,6]
NTR23-002	2:1	130 [15]	118 [13]	107 [12]	360 [41]	120 [14]	109 [12]	99 [11]	3.59 [0,41]	8.5 [1,0]
NTR23-003	3:1	83 [9]	75 [9]	68 [8]	270 [31]	76 [9]	70 [8]	63 [7]	3.09 [0,35]	9.6 [1,1]
NTR23-004	4:1	61 [7]	56 [6]	50 [6]	238 [27]	56 [6]	51 [6]	46 [5]	2.87 [0,32]	10.1 [1,1]
NTR23-005P	5:1P	50 [6]	46 [5]	41 [5]	180 [20]	46 [5]	42 [5]	38 [4]	2.81 [0,32]	10.3 [1,2]
NTR23-005T	5:1T	179 [20]	153 [17]	138 [16]	366 [41]	175 [20]	132 [15]	112 [13]	3.69 [0,42]	10.3 [1,2]
NTR23-006	6:1	153 [17]	130 [15]	126 [14]	366 [41]	149 [17]	120 [14]	116 [13]	3.67 [0,41]	6.7 [0,8]
NTR23-009	9:1	97 [11]	83 [9]	80 [9]	289 [33]	95 [11]	76 [9]	74 [8]	3.08 [0,35]	8.5 [1,0]
NTR23-010	10:1	157 [18]	144 [16]	130 [15]	366 [41]	155 [18]	138 [16]	120 [14]	3.48 [0,39]	6.6 [0,7]
NTR23-012	12:1	72 [8]	61 [7]	59 [7]	252 [28]	70 [8]	56 [6]	55 [6]	2.95 [0,33]	9.3 [1,1]
NTR23-015	15:1	100 [11]	91 [10]	83 [9]	297 [34]	99 [11]	88 [10]	76 [9]	2.89 [0,33]	9.8 [1,1]
NTR23-020	20:1	74 [8]	67 [8]	61 [7]	366 [41]	73 [8]	64 [7]	56 [6]	2.76 [0,31]	9.3 [1,0]
NTR23-025	25:1	60 [7]	55 [6]	50 [6]	198 [22]	60 [7]	53 [6]	46 [5]	2.71 [0,31]	9.8 [1,1]
NTR23-030	30:1	102 [12]	98 [11]	94 [11]	305 [34]	102 [11]	96 [11]	90 [10]	2.83 [0,32]	8.0 [0,9]
NTR23-040	40:1	75 [9]	72 [8]	69 [8]	263 [30]	75 [8]	71 [8]	67 [8]	2.69 [0,30]	9.0 [1,0]
NTR23-050	50:1	62 [7]	59 [7]	57 [6]	203 [23]	61 [7]	58 [7]	55 [6]	2.64 [0,30]	9.6 [1,1]
NTR23-060	60:1	163 [18]	161 [18]	158 [18]	366 [41]	163 [18]	160 [18]	157 [18]	3.68 [0,42]	6.5 [0,7]
NTR23-075	75:1	104 [12]	102 [12]	100 [11]	311 [35]	103 [12]	101 [11]	99 [11]	2.95 [0,33]	8.4 [0,9]
NTR23-090	90:1	104 [12]	102 [12]	101 [11]	313 [35]	103 [12]	102 [11]	100 [11]	3.09 [0,35]	8.3 [0,9]
NTR23-100	100:1	163 [18]	162 [18]	161 [18]	366 [41]	163 [18]	161 [18]	160 [18]	3.50 [0,40]	6.5 [0,7]
NTR23-120	120:1	76 [9]	75 [9]	74 [8]	270 [31]	76 [9]	75 [8]	73 [8]	2.96 [0,33]	9.2 [1,0]
NTR23-125	125:1	63 [7]	62 [7]	60 [7]	207 [23]	62 [7]	61 [7]	60 [7]	2.76 [0,31]	9.7 [1,1]
NTR23-150	150:1	104 [12]	103 [12]	102 [12]	316 [36]	104 [12]	103 [12]	102 [11]	2.91 [0,33]	8.4 [0,9]
NTR23-200	200:1	164 [19]	163 [18]	162 [18]	366 [41]	164 [18]	163 [18]	162 [18]	3.43 [0,39]	6.1 [0,7]
NTR23-250	250:1	63 [7]	62 [7]	62 [7]	207 [23]	63 [7]	62 [7]	61 [7]	2.72 [0,31]	9.7 [1,1]
NTR23-300	300:1	104 [12]	104 [12]	103 [12]	319 [36]	104 [12]	104 [12]	103 [12]	2.84 [0,32]	8.0 [0,9]
NTR23-400	400:1	77 [9]	76 [9]	76 [9]	274 [31]	77 [9]	76 [9]	76 [9]	2.71 [0,31]	9.0 [1,0]
NTR23-500	500:1	63 [7]	63 [7]	62 [7]	207 [23]	63 [7]	63 [7]	62 [7]	2.66 [0,30]	9.6 [1,1]

All ratios are available to ship in 24 hours through the Gearhead Express Program.

Ratio 5P is designed using only PowerTRUE face gearing technology.

Ratio 5T adds a True Planetary gearing stage for increased torque capacity.

<sup>1</sup> Ratios are exact, higher ratios and other custom options are also available, consult factory.

T<sub>r</sub> = Rated output torque at rated speed for specific hours of life.

J = Mass moment of inertia reflected to the input shaft (including pinion assembly)

T<sub>peak</sub> = Allowable momentary peak torque for emergency stop or heavy shock loading.

# Micron TRUE Planetary® Gearheads

## NemaTRUE™ 90 Size 34

### Right Angle Gearheads

English

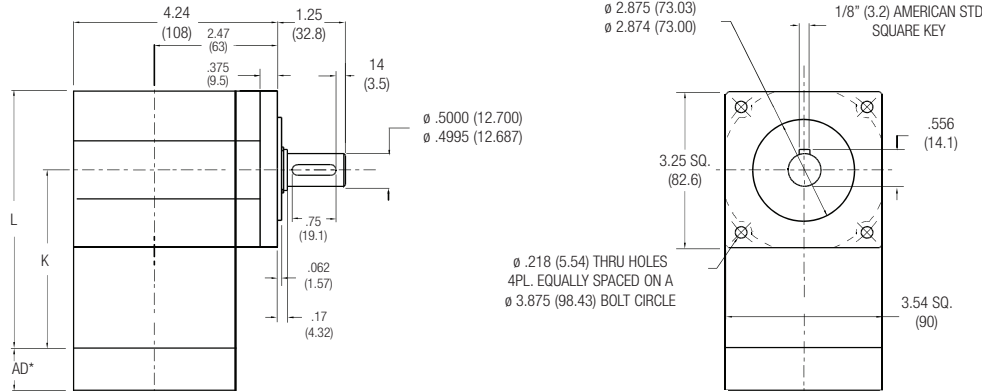

Ratio <sup>1</sup>	Dimension 'K' in. [mm]	Dimension 'L' in. [mm]	Backlash [arc-min]	Weight lb. [kg]	Efficiency
1:1 to 5:1P	3.99 [101]	5.76 [146]	13 max	6.0 [2,7]	98%
5:1T to 50:1	4.89 [124]	6.66 [169]	15 max	7.4 [3,4]	93%
60:1 to 500:1	5.79 [147]	7.56 [192]	15 max	8.8 [4,0]	88%

Dimensions are in. (mm)  
AD\*\* = Adapter length  
Adapter length will vary depending on motor.  
Efficiency is calculated at 100% of the rated torque.

### Performance Specifications

Part Number	Ratio <sup>1</sup>	10000 Hour Life			T <sub>peak</sub> in.-lb. [Nm]	20000 Hour Life			J in.-lb.-sec <sup>2</sup> x10 <sup>-4</sup> [kg-cm <sup>2</sup> ]	Torsional Stiffness in.-lb./arc-min [Nm/arc-min]
		T <sub>r</sub> (1000 rpm) in.-lb. [Nm]	T <sub>r</sub> (3000 rpm) in.-lb. [Nm]	T <sub>r</sub> (5000 rpm) in.-lb. [Nm]		T <sub>r</sub> (1000 rpm) in.-lb. [Nm]	T <sub>r</sub> (3000 rpm) in.-lb. [Nm]	T <sub>r</sub> (5000 rpm) in.-lb. [Nm]		
NTR34-001	1:1	168 [19]	153 [17]	139 [16]	493 [56]	155 [18]	142 [16]	128 [14]	27.5 [3,11]	12.6 [1,4]
NTR34-002	2:1	381 [43]	348 [39]	315 [36]	1113 [126]	352 [40]	321 [36]	291 [33]	14.1 [1,59]	19.1 [2,2]
NTR34-003	3:1	251 [28]	229 [26]	207 [23]	905 [102]	232 [26]	212 [24]	192 [22]	12.1 [1,37]	21.5 [2,4]
NTR34-004	4:1	192 [22]	176 [20]	159 [18]	695 [79]	178 [20]	162 [18]	147 [17]	11.2 [1,27]	22.6 [2,5]
NTR34-005P	5:1P	142 [16]	129 [15]	117 [13]	581 [66]	131 [15]	119 [13]	108 [12]	11.0 [1,25]	23.1 [2,6]
NTR34-005T	5:1T	508 [57]	432 [49]	420 [47]	1113 [126]	497 [56]	399 [45]	387 [44]	14.5 [1,64]	23.1 [2,6]
NTR34-006	6:1	448 [51]	381 [43]	370 [42]	1113 [126]	439 [50]	352 [40]	342 [39]	14.4 [1,63]	15.0 [1,7]
NTR34-009	9:1	296 [33]	251 [28]	244 [28]	986 [111]	289 [33]	232 [26]	225 [25]	12.1 [1,37]	19.0 [2,1]
NTR34-010	10:1	462 [52]	422 [48]	381 [43]	1113 [126]	456 [52]	404 [46]	352 [40]	13.7 [1,54]	14.8 [1,7]
NTR34-012	12:1	226 [26]	192 [22]	187 [21]	752 [85]	221 [25]	178 [20]	173 [19]	11.6 [1,31]	20.9 [2,4]
NTR34-015	15:1	305 [34]	278 [31]	251 [28]	1018 [115]	301 [34]	266 [30]	232 [26]	11.3 [1,28]	21.9 [2,5]
NTR34-020	20:1	233 [26]	213 [24]	192 [22]	1113 [126]	230 [26]	204 [23]	178 [20]	10.8 [1,22]	20.8 [2,4]
NTR34-025	25:1	172 [19]	157 [18]	142 [16]	635 [72]	169 [19]	150 [17]	131 [15]	10.6 [1,20]	21.9 [2,5]
NTR34-030	30:1	311 [35]	298 [34]	285 [32]	1045 [118]	309 [35]	292 [33]	275 [31]	11.1 [1,25]	17.9 [2,0]
NTR34-040	40:1	238 [27]	228 [26]	218 [25]	792 [89]	237 [27]	224 [25]	210 [24]	10.6 [1,19]	20.2 [2,3]
NTR34-050	50:1	175 [20]	168 [19]	160 [18]	653 [74]	174 [20]	165 [19]	155 [18]	10.4 [1,17]	21.4 [2,4]
NTR34-060	60:1	479 [54]	472 [53]	465 [53]	1113 [126]	478 [54]	469 [53]	460 [52]	14.4 [1,63]	14.5 [1,6]
NTR34-075	75:1	315 [36]	310 [35]	305 [34]	1080 [122]	314 [36]	308 [35]	301 [34]	11.6 [1,31]	18.7 [2,1]
NTR34-090	90:1	316 [36]	311 [35]	307 [35]	1085 [123]	315 [36]	309 [35]	304 [34]	12.1 [1,37]	18.6 [2,1]
NTR34-100	100:1	480 [54]	476 [54]	472 [53]	1113 [126]	479 [54]	474 [54]	469 [53]	13.7 [1,55]	14.6 [1,7]
NTR34-120	120:1	242 [27]	238 [27]	235 [27]	817 [92]	241 [27]	237 [27]	232 [26]	11.6 [1,31]	20.7 [2,3]
NTR34-125	125:1	178 [20]	175 [20]	172 [19]	666 [75]	177 [20]	173 [20]	169 [19]	10.8 [1,23]	21.8 [2,5]
NTR34-150	150:1	317 [36]	314 [35]	311 [35]	1096 [124]	316 [36]	313 [35]	309 [35]	11.4 [1,29]	18.7 [2,1]
NTR34-200	200:1	481 [54]	479 [54]	477 [54]	1113 [126]	481 [54]	478 [54]	475 [54]	13.5 [1,52]	13.6 [1,5]
NTR34-250	250:1	178 [20]	177 [20]	175 [20]	675 [76]	178 [20]	176 [20]	174 [20]	10.7 [1,21]	21.8 [2,5]
NTR34-300	300:1	317 [36]	316 [36]	315 [36]	1107 [125]	317 [36]	315 [36]	314 [35]	11.1 [1,26]	17.9 [2,0]
NTR34-400	400:1	243 [27]	242 [27]	241 [27]	832 [94]	243 [27]	241 [27]	240 [27]	10.6 [1,20]	20.2 [2,3]
NTR34-500	500:1	179 [20]	178 [20]	177 [20]	680 [77]	179 [20]	178 [20]	177 [20]	10.4 [1,18]	21.4 [2,4]

All ratios are available to ship in 24 hours through the Gearhead Express Program.

Ratio 5P is designed using only PowerTRUE face gearing technology.

Ratio 5T adds a True Planetary gearing stage for increased torque capacity.

<sup>1</sup> Ratios are exact, higher ratios and other custom options are also available, consult factory.

T<sub>r</sub> = Rated output torque at rated speed for specific hours of life.

J = Mass moment of inertia reflected to the input shaft (including pinion assembly)

T<sub>peak</sub> = Allowable momentary peak torque for emergency stop or heavy shock loading.

### Right Angle Gearheads

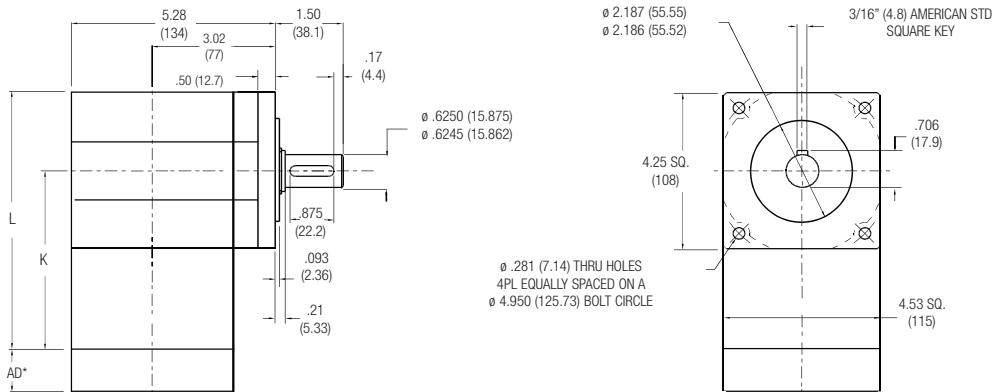

Ratio <sup>1</sup>	Dimension 'K' in [mm]	Dimension 'L' in [mm]	Backlash [arc-min]	Weight lb [kg]	Efficiency
1:1 to 5:1P	5.40 [137]	7.67 [195]	13 max	12 [5.4]	98%
5:1T to 50:1	6.63 [168.4]	8.90 [226]	15 max	14.8 [6.7]	93%
60:1 to 500:1	7.87 [200]	10.13 [257]	15 max	17.6 [8.0]	88%

Dimensions are inch (mm)  
 AD\*\* = Adapter length  
 Adapter length will vary depending on motor.  
 Efficiency is calculated at 100% of the rated torque.

### Performance Specifications

Part Number	Ratio <sup>1</sup>	10000 Hour Life			T <sub>peak</sub> in-lb [Nm]	20000 Hour Life			J in-lb-sec <sup>2</sup> × 10 <sup>-4</sup> [kg-cm <sup>2</sup> ]	Torsional Stiffness in-lb/arc-min [Nm/arc-min]
		T <sub>r</sub> (1000 rpm) in-lb [Nm]	T <sub>r</sub> (3000 rpm) in-lb [Nm]	T <sub>r</sub> (5000 rpm) in-lb [Nm]		T <sub>r</sub> (1000 rpm) in-lb [Nm]	T <sub>r</sub> (3000 rpm) in-lb [Nm]	T <sub>r</sub> (5000 rpm) in-lb [Nm]		
NTR42-001	1:1	496 [56]	452 [51]	409 [46]	1620 [183]	458 [52]	418 [47]	378 [43]	46.7 [5.28]	15.0 [1.7]
NTR42-002	2:1	885 [100]	808 [91]	730 [83]	2255 [255]	817 [92]	746 [84]	674 [76]	23.9 [2.71]	24.7 [2.8]
NTR42-003	3:1	687 [78]	627 [71]	567 [64]	2039 [230]	635 [72]	579 [65]	524 [59]	20.6 [2.33]	28.0 [3.2]
NTR42-004	4:1	458 [52]	418 [47]	378 [43]	1584 [179]	423 [48]	386 [44]	349 [39]	19.1 [2.16]	29.4 [3.3]
NTR42-005P	5:1P	343 [39]	313 [35]	283 [32]	1305 [147]	317 [36]	289 [33]	261 [30]	18.8 [2.12]	30.0 [3.4]
NTR42-005T	5:1T	1346 [152]	1117 [126]	958 [108]	2255 [255]	1262 [143]	907 [102]	778 [88]	24.6 [2.78]	30.0 [3.4]
NTR42-006	6:1	1041 [118]	885 [100]	859 [97]	2255 [255]	1018 [115]	817 [92]	794 [90]	24.5 [2.77]	20.1 [2.3]
NTR42-009	9:1	808 [91]	687 [78]	667 [75]	2241 [253]	791 [89]	635 [72]	616 [70]	20.5 [2.32]	25.1 [2.8]
NTR42-010	10:1	1072 [121]	979 [111]	885 [100]	2255 [255]	1059 [120]	938 [106]	817 [92]	23.2 [2.63]	20.1 [2.3]
NTR42-012	12:1	538 [61]	458 [52]	444 [50]	1728 [195]	526 [59]	423 [48]	410 [46]	19.6 [2.22]	27.5 [3.1]
NTR42-015	15:1	832 [94]	760 [86]	687 [78]	2255 [255]	822 [93]	728 [82]	635 [72]	19.3 [2.18]	28.8 [3.3]
NTR42-020	20:1	554 [63]	506 [57]	458 [52]	2255 [255]	547 [62]	485 [55]	423 [48]	18.4 [2.08]	27.5 [3.1]
NTR42-025	25:1	416 [47]	379 [43]	343 [39]	1458 [165]	410 [46]	364 [41]	317 [36]	18.0 [2.04]	28.8 [3.2]
NTR42-030	30:1	851 [96]	814 [92]	778 [88]	2255 [255]	845 [96]	798 [90]	752 [85]	18.9 [2.13]	24.6 [2.8]
NTR42-040	40:1	566 [64]	542 [61]	518 [59]	1836 [207]	563 [64]	532 [60]	500 [57]	18.0 [2.03]	27.2 [3.1]
NTR42-050	50:1	425 [48]	407 [46]	388 [44]	1499 [169]	422 [48]	399 [45]	375 [42]	17.6 [1.99]	28.5 [3.2]
NTR42-060	60:1	1111 [126]	1095 [124]	1080 [122]	2255 [255]	1109 [125]	1089 [123]	1069 [121]	24.6 [2.78]	19.7 [2.2]
NTR42-075	75:1	861 [97]	847 [96]	832 [94]	2255 [255]	859 [97]	841 [95]	822 [93]	19.7 [2.22]	25.0 [2.8]
NTR42-090	90:1	863 [97]	851 [96]	838 [95]	2255 [255]	861 [97]	845 [96]	830 [94]	20.6 [2.33]	24.8 [2.8]
NTR42-100	100:1	1114 [126]	1105 [125]	1095 [124]	2255 [255]	1113 [126]	1101 [124]	1089 [123]	23.3 [2.64]	19.9 [2.2]
NTR42-120	120:1	574 [65]	566 [64]	558 [63]	1897 [214]	573 [65]	563 [64]	552 [62]	19.7 [2.23]	27.3 [3.1]
NTR42-125	125:1	430 [49]	423 [48]	416 [47]	1539 [174]	429 [48]	420 [47]	410 [46]	18.4 [2.08]	28.7 [3.2]
NTR42-150	150:1	865 [98]	858 [97]	851 [96]	2255 [255]	864 [98]	855 [97]	845 [96]	19.4 [2.19]	25.0 [2.8]
NTR42-200	200:1	1116 [126]	1112 [126]	1107 [125]	2255 [255]	1116 [126]	1110 [125]	1104 [125]	22.9 [2.59]	19.4 [2.2]
NTR42-250	250:1	432 [49]	428 [48]	425 [48]	1562 [176]	431 [49]	427 [48]	422 [48]	18.1 [2.05]	28.7 [3.2]
NTR42-300	300:1	867 [98]	863 [98]	860 [97]	2255 [255]	866 [98]	862 [97]	857 [97]	18.9 [2.14]	24.6 [2.8]
NTR42-400	400:1	577 [65]	575 [65]	572 [65]	1944 [220]	577 [65]	574 [65]	571 [64]	18.1 [2.04]	27.1 [3.1]
NTR42-500	500:1	433 [49]	431 [49]	429 [48]	1580 [178]	433 [49]	430 [49]	428 [48]	17.7 [2.00]	28.5 [3.2]

All ratios are available to ship in 24 hours through the Gearhead Express Program.

Ratio 5P is designed using only PowerTRUE face gearing technology.

Ratio 5T adds a True Planetary gearing stage for increased torque capacity.

<sup>1</sup> Ratios are exact, higher ratios and other custom options are also available, consult factory.

T<sub>r</sub> = Rated output torque at rated speed for specific hours of life.

J = Mass moment of inertia reflected to the input shaft (including pinion assembly)

T<sub>peak</sub> = Allowable momentary peak torque for emergency stop or heavy shock loading.

# Micron TRUE Planetary® Gearheads

## Radial and Axial Load Ratings

### NTR23

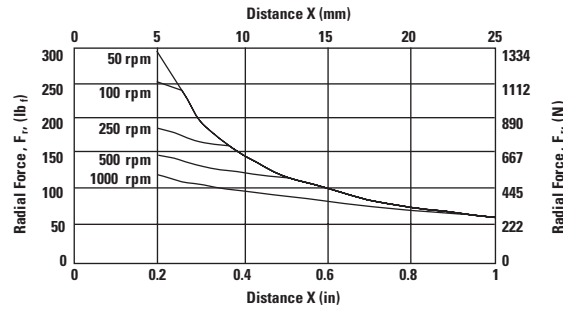
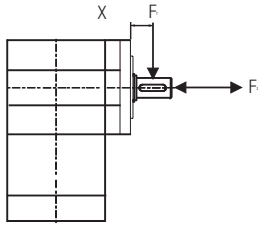

Speed rpm	Axial Load, $F_a$ lb <sub>f</sub> [N]
50	250 [1110]
100	200 [890]
250	150 [670]
500	120 [530]
1000	90 [400]

### NTR34

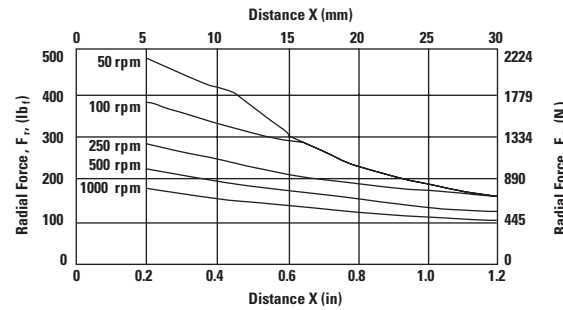
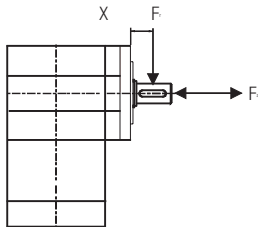

Speed rpm	Axial Load, $F_a$ lb <sub>f</sub> [N]
50	340 [1510]
100	270 [1200]
250	200 [890]
500	160 [710]
1000	130 [580]

### NTR42

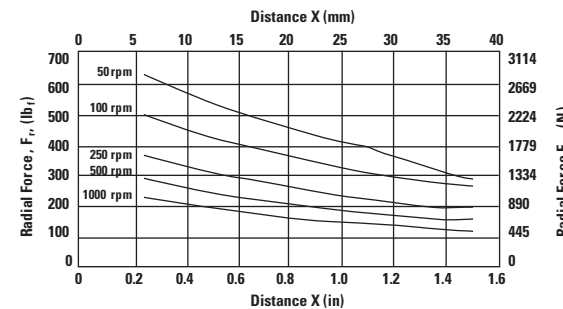
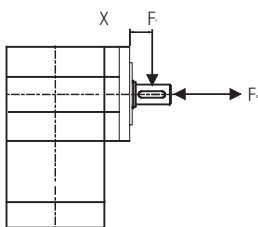

Speed rpm	Axial Load, $F_a$ lb <sub>f</sub> [N]
50	460 [2050]
100	370 [1650]
250	270 [1200]
500	210 [930]
1000	170 [760]

These graphs display the allowable radial load at a given distance (X) from the mounting surface based on an  $L_{10}$  life of 10,000 hours for the mean output speed  $n_{mout}$ , as described on page 9.

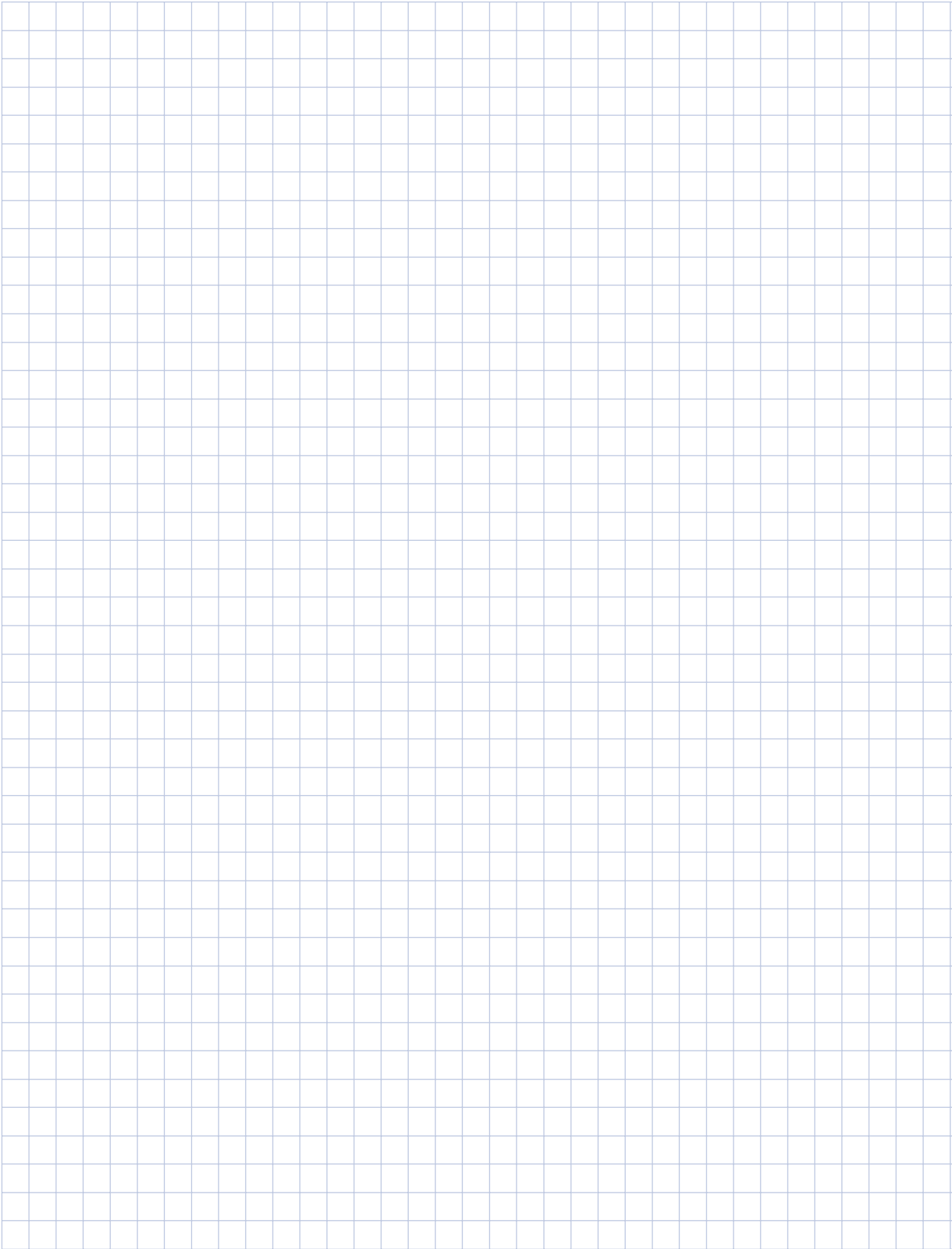

# Micron TRUE Planetary® Gearheads

## DuraTRUE™

Ready for Immediate Delivery	
Precision	8 arc-minutes
Frame Sizes	60 mm, 90 mm, 115 mm and 142 mm
Torque Capacity	up to 834 Nm
Ratio Availability	3:1 thru 100:1
Radial load capacity	up to 11150 N
Mounting System	RediMount™

- 1 Sealed deep groove ball bearings**  
provide high radial load carrying capability
- 2 HRC 55-60 steel gears**  
provide superior wear resistance and increased backlash integrity
- 3 Sealed deep groove ball bearing**  
provides precision alignment of sun gear
- 4 RediMount system**  
provides error-free motor installation
- 5 Anodized aluminum housing**  
reduces weight and prevents corrosion

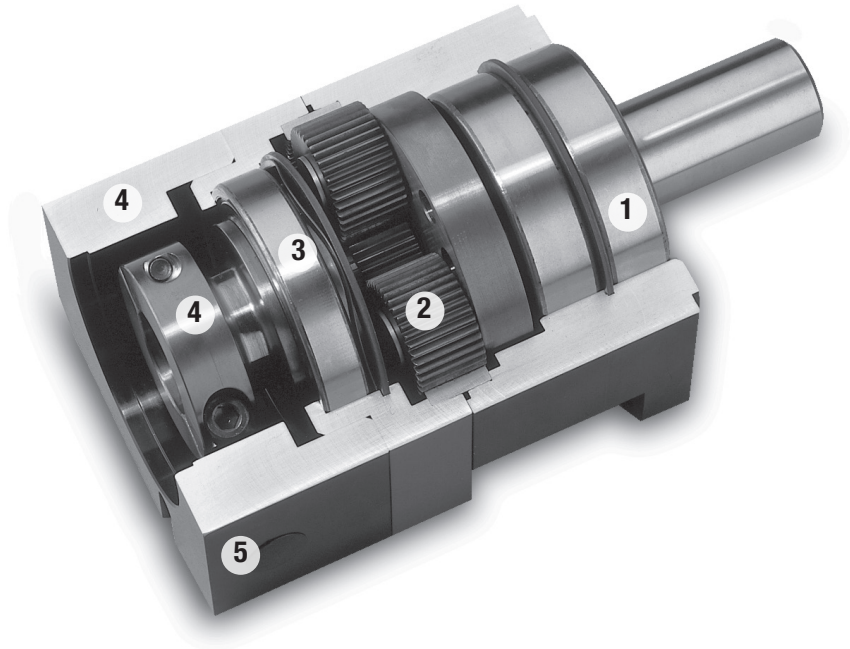

*Micron True Planetary® Gearheads  
shipped within 24 hours!*

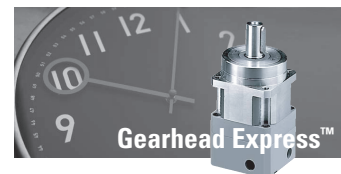

*Need it fast? Go to the back cover  
of the catalog for details.*



# Micron TRUE Planetary® Gearheads

## DuraTRUE Size 60

### Metric

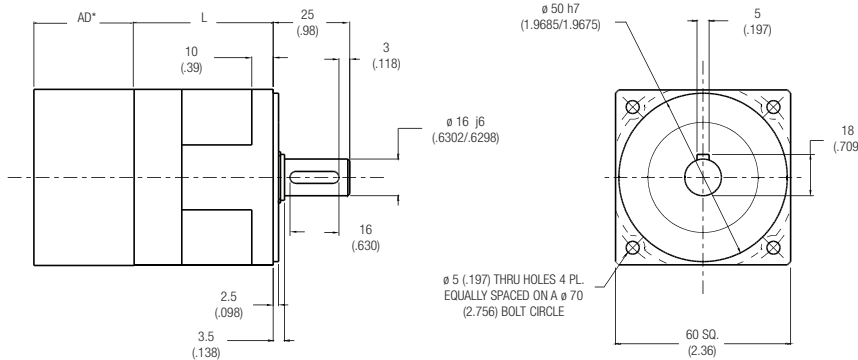

Ratio <sup>1</sup>	Dimension 'L' mm [in.]	Backlash [arc-min]	Weight kg [lb.]	Efficiency
3:1 to 10:1	53 [2.07]	8 max	1,0 [2.2]	93%
15:1 to 100:1	70 [2.76]	9 max	1,2 [2.7]	88%

All dimensions are: mm (in.)  
 AD\*\* = Adapter length  
 Adapter length will vary depending on motor.  
 Efficiency is calculated at 100% of the rated torque.

## Performance Specifications

Part Number	Ratio <sup>1</sup>	10000 Hour Life				T <sub>peak</sub> Nm [in.-lb.]	20000 Hour Life				J kg-cm <sup>2</sup> [in.-lb.-sec <sup>2</sup> x10 <sup>-4</sup> ]	Torsional Stiffness Nm/arc-min [in.-lb./arc-min]
		T <sub>r</sub> (1000 rpm) Nm [in.-lb.]	T <sub>r</sub> (2000 rpm) Nm [in.-lb.]	T <sub>r</sub> (3000 rpm) Nm [in.-lb.]	T <sub>r</sub> (4000 rpm) Nm [in.-lb.]		T <sub>r</sub> (1000 rpm) Nm [in.-lb.]	T <sub>r</sub> (2000 rpm) Nm [in.-lb.]	T <sub>r</sub> (3000 rpm) Nm [in.-lb.]	T <sub>r</sub> (4000 rpm) Nm [in.-lb.]		
DT060-003	3:1	15 [134]	12 [109]	11 [97]	89 [10]	52 [460]	12 [109]	10 [89]	9 [79]	8 [72]	0,52 [4.6]	0,9 [8.1]
DT060-004	4:1	19 [168]	16 [142]	14 [124]	115 [13]	44 [385]	16 [142]	13 [115]	12 [106]	11 [97]	0,46 [4.1]	0,9 [7.9]
DT060-005	5:1	17 [148]	14 [120]	12 [106]	98 [11]	46 [410]	14 [120]	11 [98]	10 [86]	9 [79]	0,46 [4.1]	0,9 [7.9]
DT060-007	7:1	16 [142]	13 [115]	11 [97]	89 [10]	41 [363]	13 [115]	10 [89]	9 [80]	8 [71]	0,46 [4.1]	0,9 [7.9]
DT060-010	10:1	15 [134]	14 [121]	13 [114]	108 [12]	45 [400]	14 [124]	13 [112]	11 [100]	10 [92]	0,44 [3.9]	0,8 [6.8]
DT060-015	15:1	25 [218]	20 [177]	18 [157]	144 [16]	52 [460]	20 [177]	16 [144]	14 [127]	13 [117]	0,46 [4.1]	0,9 [8.2]
DT060-020	20:1	26 [230]	24 [212]	21 [186]	177 [20]	46 [407]	24 [212]	20 [177]	18 [159]	17 [150]	0,46 [4.1]	0,9 [7.9]
DT060-025	25:1	24 [214]	22 [195]	19 [172]	158 [18]	52 [456]	22 [195]	18 [158]	16 [140]	15 [128]	0,46 [4.1]	0,9 [8.3]
DT060-030	30:1	28 [246]	25 [218]	22 [193]	177 [20]	52 [460]	25 [218]	20 [177]	18 [157]	16 [144]	0,44 [3.9]	1,0 [8.7]
DT060-040	40:1	27 [239]	26 [230]	26 [230]	212 [24]	46 [407]	27 [239]	24 [212]	21 [186]	20 [177]	0,44 [3.9]	0,9 [8.3]
DT060-050	50:1	25 [222]	24 [214]	24 [209]	195 [22]	52 [460]	25 [217]	22 [195]	19 [172]	18 [158]	0,44 [3.9]	0,9 [8.2]
DT060-070	70:1	24 [212]	23 [204]	23 [204]	186 [21]	46 [407]	24 [212]	21 [186]	18 [159]	17 [150]	0,44 [3.9]	0,9 [8.3]
DT060-100	100:1	20 [180]	19 [165]	18 [157]	151 [17]	51 [447]	19 [167]	17 [153]	16 [145]	16 [140]	0,44 [3.9]	0,9 [7.8]

All ratios are available to ship in 24 hours through the Gearhead Express Program.

<sup>1</sup> Ratios are exact, higher ratios and other custom options are also available, consult factory.

T<sub>r</sub> = Rated output torque at rated speed for specific hours of life.

T<sub>peak</sub> = Allowable momentary peak torque for emergency stop or heavy shock loading.  
 J = Mass moment of inertia reflected to the input shaft (including pinion assembly).

# Micron TRUE Planetary® Gearheads

## DuraTRUE™ Size 90

Metric

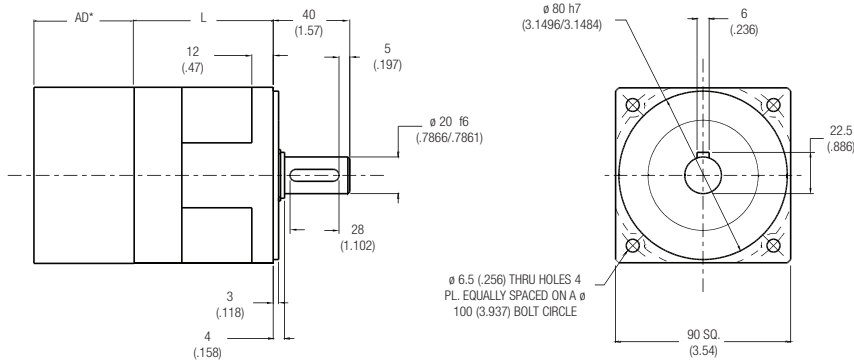

Ratio <sup>1</sup>	Dimension 'L' mm [in.]	Backlash [arc-min]	Weight kg [lb.]	Efficiency
3:1 to 10:1	67 [2.63]	8 max	3,0 [6.6]	93%
15:1 to 100:1	90 [3.53]	9 max	3,7 [8.1]	88%

All dimensions are: mm (in.)  
 AD\*\* = Adapter length  
 Adapter length will vary depending on motor.  
 Efficiency is calculated at 100% of the rated torque.

## Performance Specifications

Part Number	Ratio <sup>1</sup>	10000 Hour Life				T <sub>peak</sub> Nm [in.-lb.]	20000 Hour Life				J kg-cm <sup>2</sup> [in.-lb.-sec <sup>2</sup> x10 <sup>-4</sup> ]	Torsional Stiffness Nm/arc-min [in.-lb./arc-min]
		T <sub>r</sub> (1000 rpm) Nm [in.-lb.]	T <sub>r</sub> (2000 rpm) Nm [in.-lb.]	T <sub>r</sub> (3000 rpm) Nm [in.-lb.]	T <sub>r</sub> (4000 rpm) Nm [in.-lb.]		T <sub>r</sub> (1000 rpm) Nm [in.-lb.]	T <sub>r</sub> (2000 rpm) Nm [in.-lb.]	T <sub>r</sub> (3000 rpm) Nm [in.-lb.]	T <sub>r</sub> (4000 rpm) Nm [in.-lb.]		
DT090-003	3:1	69 [614]	56 [499]	50 [442]	46 [405]	167 [1479]	56 [499]	46 [405]	41 [359]	37 [329]	2,22 [1.97]	4,9 [43.3]
DT090-004	4:1	80 [708]	67 [593]	60 [531]	55 [487]	157 [1389]	67 [593]	55 [487]	50 [443]	46 [407]	1,84 [1.60]	4,8 [42.4]
DT090-005	5:1	75 [664]	62 [549]	55 [486]	50 [446]	157 [1385]	62 [549]	50 [446]	45 [395]	41 [362]	1,76 [1.56]	4,8 [42.9]
DT090-007	7:1	73 [646]	60 [531]	53 [469]	48 [425]	157 [1389]	60 [531]	48 [425]	43 [381]	38 [336]	1,72 [1.50]	4,8 [42.4]
DT090-010	10:1	55 [488]	50 [439]	46 [411]	44 [392]	157 [1390]	51 [452]	46 [407]	43 [381]	41 [363]	1,63 [1.44]	4,0 [35.6]
DT090-015	15:1	93 [826]	84 [747]	79 [702]	74 [657]	167 [1479]	86 [764]	74 [657]	66 [582]	60 [534]	1,78 [1.58]	4,9 [43.7]
DT090-020	20:1	89 [788]	86 [761]	84 [743]	82 [726]	167 [1478]	88 [779]	84 [743]	77 [681]	71 [628]	1,77 [1.60]	4,8 [42.4]
DT090-025	25:1	84 [747]	81 [714]	78 [693]	77 [677]	167 [1479]	83 [730]	79 [698]	72 [640]	66 [587]	1,77 [1.56]	5,0 [44.5]
DT090-030	30:1	103 [908]	93 [826]	88 [780]	84 [747]	167 [1479]	95 [840]	86 [764]	81 [716]	74 [657]	1,64 [1.45]	4,9 [43.4]
DT090-040	40:1	93 [823]	89 [788]	87 [770]	86 [761]	167 [1478]	91 [805]	88 [779]	86 [761]	84 [743]	1,64 [1.40]	5,0 [44.2]
DT090-050	50:1	88 [776]	84 [747]	82 [728]	81 [714]	167 [1479]	86 [759]	83 [730]	81 [712]	79 [698]	1,63 [1.45]	5,0 [44.2]
DT090-070	70:1	86 [761]	82 [726]	80 [708]	79 [699]	167 [1478]	84 [743]	81 [717]	79 [699]	78 [690]	1,63 [1.40]	5,0 [44.2]
DT090-100	100:1	75 [663]	69 [608]	65 [576]	63 [555]	167 [1479]	69 [613]	64 [562]	60 [533]	58 [513]	1,63 [1.45]	4,4 [38.5]

All ratios are available to ship in 24 hours through the Gearhead Express Program.

<sup>1</sup> Ratios are exact, higher ratios and other custom options are also available, consult factory.  
 T<sub>r</sub> = Rated output torque at rated speed for specific hours of life.

T<sub>peak</sub> = Allowable momentary peak torque for emergency stop or heavy shock loading.  
 J = Mass moment of inertia reflected to the input shaft (including pinion assembly).

# Micron TRUE Planetary® Gearheads

## DuraTRUE Size 115

Metric

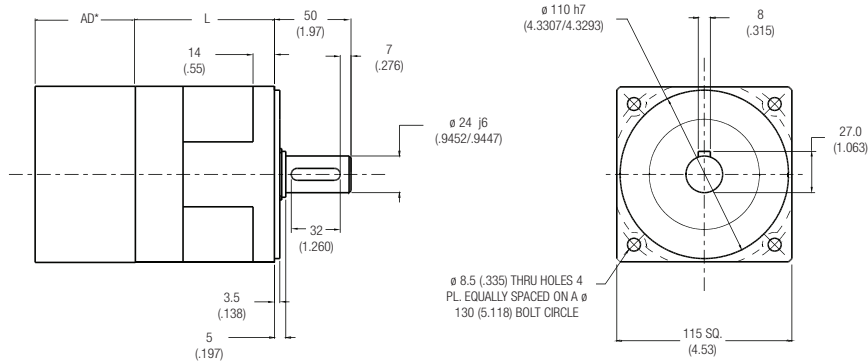

Ratio <sup>1</sup>	Dimension 'L' mm [in]	Backlash [arc-min]	Weight kg [lb]	Efficiency
3:1 to 10:1	88 [3.46]	8 max	5,7 [12.7]	93%
15:1 to 100:1	119 [4.69]	9 max	7,3 [16.2]	88%

All dimensions are: mm (inch)

AD\*\* = Adapter length

Adapter length will vary depending on motor.

Efficiency is calculated at 100% of the rated torque.

## Performance Specifications

Part Number	Ratio <sup>1</sup>	10000 Hour Life				T <sub>peak</sub> Nm [in-lb]	20000 Hour Life				J kg-cm <sup>2</sup> [in-lb-sec <sup>2</sup> ×10 <sup>-4</sup> ]	Torsional Stiffness Nm/arc-min [in-lb/arc-min]
		T <sub>r</sub> (1000 rpm) Nm [in-lb]	T <sub>r</sub> (2000 rpm) Nm [in-lb]	T <sub>r</sub> (3000 rpm) Nm [in-lb]	T <sub>r</sub> (4000 rpm) Nm [in-lb]		T <sub>r</sub> (1000 rpm) Nm [in-lb]	T <sub>r</sub> (2000 rpm) Nm [in-lb]	T <sub>r</sub> (3000 rpm) Nm [in-lb]	T <sub>r</sub> (4000 rpm) Nm [in-lb]		
DT115-003	3:1	105 [932]	86 [757]	76 [670]	70 [615]	284 [2511]	86 [757]	70 [615]	62 [544]	56 [499]	4,39 [3.88]	13,9 [123.4]
DT115-004	4:1	123 [1089]	98 [867]	91 [805]	85 [752]	284 [2513]	102 [903]	85 [752]	75 [664]	70 [620]	3,1 [2.7]	13,9 [122.7]
DT115-005	5:1	116 [1025]	91 [803]	83 [738]	77 [677]	284 [2511]	94 [833]	77 [677]	68 [599]	62 [550]	2,88 [2.55]	11,6 [102.4]
DT115-007	7:1	113 [1000]	88 [779]	81 [717]	75 [664]	284 [2513]	92 [814]	75 [664]	65 [575]	60 [531]	2,81 [2.5]	13,9 [122.7]
DT115-010	10:1	90 [796]	81 [715]	76 [668]	72 [635]	284 [2511]	83 [737]	75 [661]	70 [618]	66 [588]	2,47 [2.18]	11,6 [102.4]
DT115-015	15:1	171 [1510]	139 [1226]	123 [1086]	113 [996]	284 [2511]	139 [1226]	113 [996]	100 [882]	91 [809]	2,95 [2.61]	12,9 [114.1]
DT115-020	20:1	175 [1549]	161 [1425]	143 [1266]	132 [1168]	284 [2513]	161 [1425]	132 [1168]	118 [1044]	109 [965]	2,95 [2.6]	13,9 [122.7]
DT115-025	25:1	167 [1474]	153 [1350]	135 [1195]	124 [1096]	284 [2511]	153 [1350]	124 [1096]	110 [971]	101 [891]	2,90 [2.57]	14,1 [125.0]
DT115-030	30:1	203 [1794]	171 [218]	151 [1337]	139 [1226]	284 [2513]	171 [1510]	139 [1226]	123 [1086]	113 [996]	2,48 [2.20]	14,1 [124.4]
DT115-040	40:1	181 [1602]	175 [1549]	190 [1682]	161 [1425]	284 [2513]	178 [1575]	161 [1425]	143 [1266]	132 [1168]	2,47 [2.2]	14,1 [124.4]
DT115-050	50:1	173 [1535]	167 [1474]	162 [1435]	153 [1350]	284 [2511]	170 [1510]	153 [1350]	135 [1195]	124 [1096]	2,47 [2.19]	14,1 [125.0]
DT115-070	70:1	171 [1513]	165 [1460]	180 [1593]	151 [1336]	284 [2513]	168 [1487]	151 [1336]	133 [1177]	122 [1080]	2,47 [2.2]	14,1 [124.4]
DT115-100	100:1	123 [1087]	112 [995]	107 [943]	103 [907]	284 [2511]	114 [1006]	104 [921]	99 [873]	95 [840]	2,47 [2.19]	11,4 [100.6]

All ratios are available to ship in 24 hours through the Gearhead Express Program.

<sup>1</sup> Ratios are exact, higher ratios and other custom options are also available, consult factory.

T<sub>r</sub> = Rated output torque at rated speed for specific hours of life.

T<sub>peak</sub> = Allowable momentary peak torque for emergency stop or heavy shock loading.

J = Mass moment of inertia reflected to the input shaft (including pinion assembly).

# Micron TRUE Planetary® Gearheads

## DuraTRUE™ Size 142

### True Planetary Gearheads

Metric

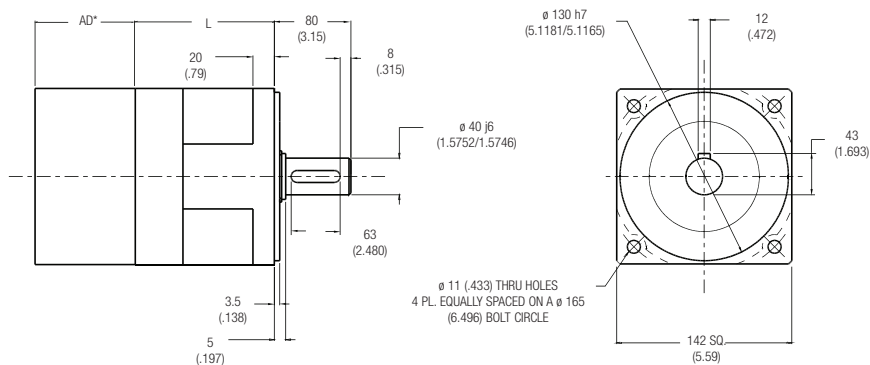

Ratio <sup>1</sup>	Dimension 'L' mm [in.]	Backlash [arc-min]	Weight kg [lb.]	Efficiency
3:1 to 10:1	121 [4.77]	8 max	12,8 [28.3]	93%
15:1 to 100:1	170 [6.71]	9 max	17,2 [38.0]	88%

All dimensions are: mm (in.)  
 AD\*\* = Adapter length  
 Adapter length will vary depending on motor.  
 Efficiency is calculated at 100% of the rated torque.

## Performance Specifications

Part Number	Ratio <sup>1</sup>	10000 Hour Life				T <sub>peak</sub> Nm [in.-lb.]	20000 Hour Life				J kg-cm <sup>2</sup> [in.-lb.-sec <sup>2</sup> ×10 <sup>-4</sup> ]	Torsional Stiffness Nm/arc-min [in.-lb./arc-min]
		T <sub>r</sub> (1000 rpm) Nm [in.-lb.]	T <sub>r</sub> (2000 rpm) Nm [in.-lb.]	T <sub>r</sub> (3000 rpm) Nm [in.-lb.]	T <sub>r</sub> (4000 rpm) Nm [in.-lb.]		T <sub>r</sub> (1000 rpm) Nm [in.-lb.]	T <sub>r</sub> (2000 rpm) Nm [in.-lb.]	T <sub>r</sub> (3000 rpm) Nm [in.-lb.]	T <sub>r</sub> (4000 rpm) Nm [in.-lb.]		
DT142-003	3:1	372 [3289]	302 [2671]	267 [2365]	245 [2170]	834 [7377]	302 [2671]	245 [2170]	217 [1921]	199 [1762]	23,2 [2.05]	51,8 [458.7]
DT142-004	4:1	430 [3806]	353 [3124]	315 [2788]	290 [2567]	834 [7381]	353 [3124]	290 [2567]	259 [2292]	239 [2115]	15,1 [1.3]	52,9 [467.1]
DT142-005	5:1	410 [3625]	333 [2944]	295 [2607]	270 [2391]	834 [7377]	333 [2944]	270 [2391]	239 [2118]	219 [1942]	14,7 [1.30]	52,6 [465.1]
DT142-007	7:1	405 [3584]	328 [2903]	290 [2597]	265 [2345]	834 [7381]	328 [2903]	265 [2345]	234 [2071]	214 [1894]	14,5 [1.3]	50,5 [445.9]
DT142-010	10:1	229 [2022]	204 [1808]	190 [1685]	181 [1598]	834 [7377]	211 [1871]	189 [1673]	176 [1559]	167 [1479]	12,1 [1.07]	41,3 [365.1]
DT142-015	15:1	524 [4634]	471 [4167]	433 [3833]	397 [3516]	834 [7377]	484 [4287]	397 [3516]	352 [3114]	323 [2856]	15,1 [1.34]	59,6 [527.6]
DT142-020	20:1	500 [4425]	476 [4213]	461 [4080]	450 [3983]	834 [7381]	489 [4328]	458 [4053]	408 [3611]	376 [3328]	14,8 [1.3]	58,5 [516.6]
DT142-025	25:1	480 [4248]	456 [4038]	441 [3903]	430 [3801]	834 [7377]	469 [4154]	438 [3876]	388 [3432]	356 [3148]	14,8 [1.31]	57,7 [510.6]
DT142-030	30:1	578 [5113]	524 [4634]	493 [4359]	471 [4167]	834 [7377]	535 [4731]	484 [4287]	433 [3833]	397 [3516]	12,2 [1.08]	59,9 [529.9]
DT142-040	40:1	521 [4611]	500 [4425]	486 [4301]	476 [4213]	834 [7381]	510 [4514]	489 [4328]	476 [4213]	458 [4053]	12,9 [1.1]	57,5 [507.7]
DT142-050	50:1	501 [4435]	480 [4248]	466 [4128]	456 [4038]	834 [7377]	490 [4336]	469 [4154]	456 [4037]	438 [3876]	12,1 [1.07]	57,8 [511.1]
DT142-070	70:1	496 [4390]	475 [4204]	461 [4080]	451 [3991]	834 [7381]	485 [4292]	464 [4106]	451 [3991]	433 [3882]	12,1 [1.1]	54,4 [480.4]
DT142-100	100:1	314 [2782]	287 [2543]	272 [2408]	262 [2314]	834 [7377]	291 [2574]	266 [2353]	252 [2228]	242 [2141]	12,1 [1.07]	42,9 [379.5]

All ratios are available to ship in 24 hours through the Gearhead Express Program.

<sup>1</sup> Ratios are exact, higher ratios and other custom options are also available, consult factory.  
 T<sub>r</sub> = Rated output torque at rated speed for specific hours of life.

T<sub>peak</sub> = Allowable momentary peak torque for emergency stop or heavy shock loading.  
 J = Mass moment of inertia reflected to the input shaft (including pinion assembly).

## Radial and Axial Load Ratings

### DT060

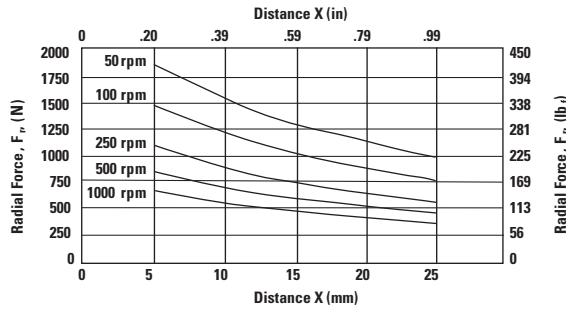
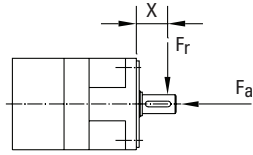

Speed rpm	Axial Load, $F_a$ N [lb.]
50	3075 [692]
100	2441 [549]
250	1798 [405]
500	1427 [321]
1000	1133 [255]

### DT090

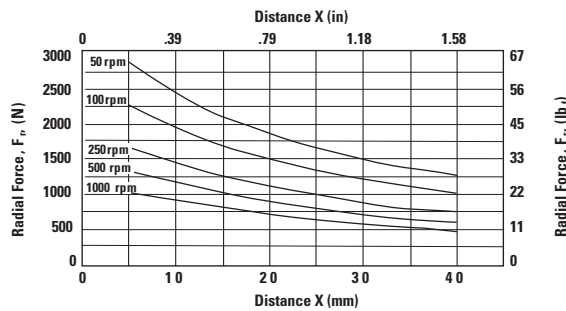
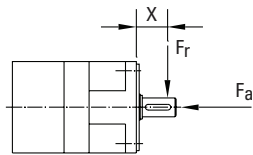

Speed rpm	Axial Load, $F_a$ N [lb.]
50	4506 [1014]
100	3576 [805]
250	2635 [593]
500	2091 [471]
1000	1660 [373]

### DT115

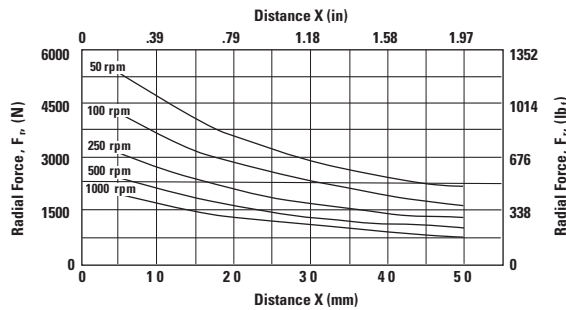
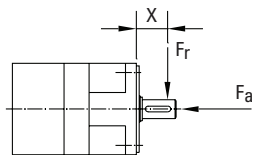

Speed rpm	Axial Load, $F_a$ N [lb.]
50	8196 [1844]
100	6505 [1464]
250	4793 [1078]
500	3804 [856]
1000	3019 [679]

### DT142

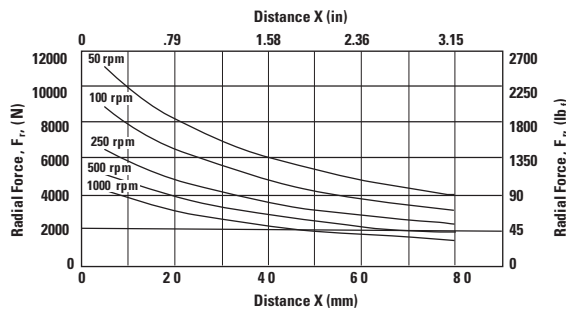
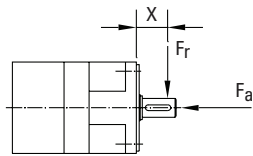

Speed rpm	Axial Load, $F_a$ N [lb.]
50	17023 [3830]
100	13511 [3040]
250	9956 [2240]
500	7902 [1778]
1000	6271 [1411]

These graphs display the allowable radial load at a given distance (X) from the mounting surface based on an  $L_{10}$  life of 10,000 hours for the mean output speed  $n_{mout}$ , as described on page 9.

# Micron TRUE Planetary® Gearheads

## DuraTRUE™ 90

### Right Angle Gearheads

Ready for Immediate Delivery	
Precision	8 arc-minutes
Frame Sizes	60 mm, 90 mm, 115 mm and 142 mm
Torque Capacity	up to 865 Nm
Ratio Availability	1:1 thru 500:1
Radial load capacity	up to 11150 N
Mounting System	RediMount™

- 1 Deep groove ball bearings**  
provide high radial load carrying capabilities
- 2 HRC 55-60 steel gears**  
provide superior wear resistance and increased backlash integrity
- 3 Innovative PowerTRUE™ gearing**  
delivers smooth, quiet geared reduction
- 4 RediMount system**  
provides error-free installation

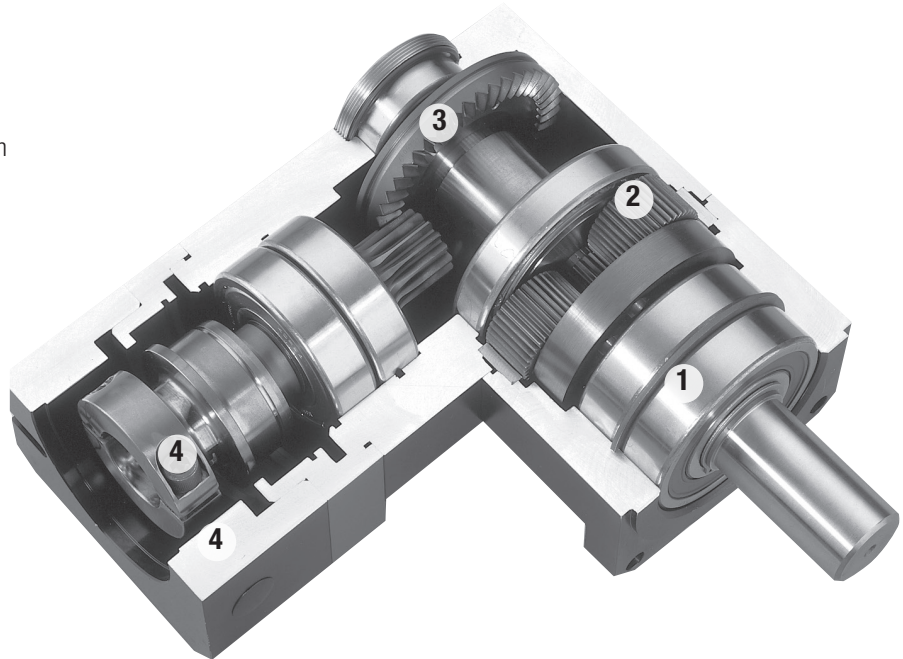

**Micron True Planetary® Gearheads  
shipped within 24 hours!**

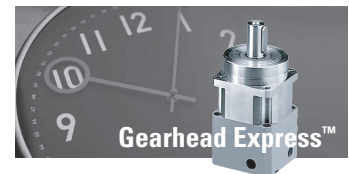

**Need it fast? Go to the back cover  
of the catalog for details.**

### Right Angle Gearheads

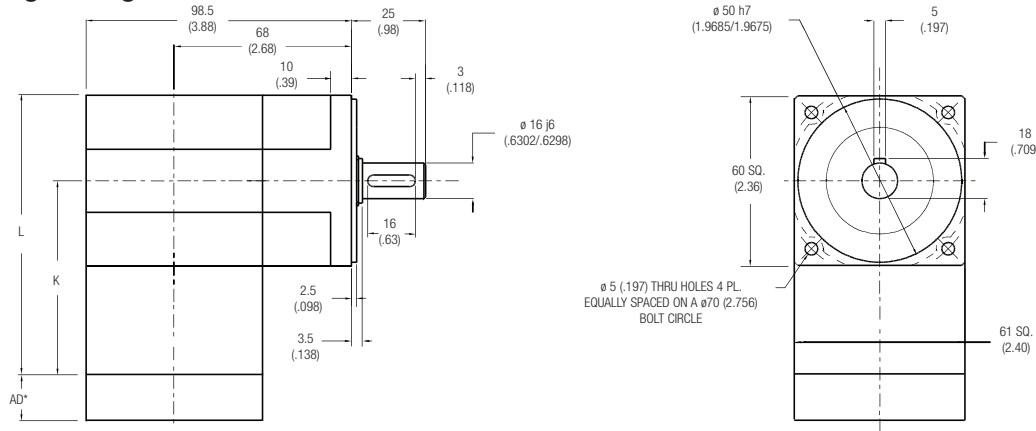

Ratio <sup>1</sup>	Dimension 'K' mm [in.]	Dimension 'L' mm [in.]	Backlash [arc-min]	Weight kg [lb.]	Efficiency
5:1 to 50:1	79 [3.11]	109,5 [4.31]	9 max	2,5 [5.5]	93%
60:1 to 500:1	96 [3.79]	127 [4.99]	9 max	2,7 [6]	88%

All dimensions are: mm (in.)  
 AD\*\* = Adapter length  
 Adapter length will vary depending on motor.  
 Efficiency is calculated at 100% of the rated torque.

## Performance Specifications

Part Number	Ratio <sup>1</sup>	10000 Hour Life			T <sub>peak</sub> Nm [in.-lb.]	20000 Hour Life			J kg-cm <sup>2</sup> [in.-lb.-sec <sup>2</sup> x10 <sup>-4</sup> ]	Torsional Stiffness Nm/arc-min [in.-lb./arc-min]
		T <sub>r</sub> (1000 rpm) Nm [in.-lb.]	T <sub>r</sub> (3000 rpm) Nm [in.-lb.]	T <sub>r</sub> (5000 rpm) Nm [in.-lb.]		T <sub>r</sub> (1000 rpm) Nm [in.-lb.]	T <sub>r</sub> (3000 rpm) Nm [in.-lb.]	T <sub>r</sub> (5000 rpm) Nm [in.-lb.]		
DTR060-005	5:1	18 [157]	13 [113]	11 [97]	52 [460]	14 [127]	10 [92]	9 [79]	0,42 [3.7]	2,3 [20.1]
DTR060-006	6:1	19 [166]	13 [119]	12 [102]	52 [460]	15 [134]	11 [97]	9 [83]	0,42 [3.7]	2,3 [20.3]
DTR060-009	9:1	21 [187]	15 [134]	13 [115]	52 [460]	17 [152]	12 [109]	11 [94]	0,36 [3.1]	2,3 [20.2]
DTR060-010	10:1	21 [182]	15 [131]	13 [112]	49 [435]	17 [148]	12 [106]	10 [91]	0,41 [3.5]	2,3 [20.2]
DTR060-012	12:1	18 [161]	17 [147]	14 [126]	45 [402]	18 [161]	13 [119]	12 [102]	0,33 [3.0]	2,3 [20.4]
DTR060-015	15:1	23 [206]	17 [148]	14 [127]	50 [445]	19 [167]	14 [120]	12 [103]	0,32 [2.9]	2,3 [20.4]
DTR060-020	20:1	24 [211]	18 [161]	16 [138]	51 [450]	21 [182]	15 [131]	13 [112]	0,33 [2.8]	2,3 [20.3]
DTR060-025	25:1	24 [214]	19 [172]	17 [148]	51 [455]	22 [195]	16 [140]	14 [120]	0,32 [2.7]	2,3 [20.3]
DTR060-030	30:1	18 [155]	15 [134]	14 [124]	49 [430]	16 [143]	14 [124]	13 [115]	0,35 [2.8]	1,7 [14.8]
DTR060-040	40:1	18 [161]	16 [139]	15 [130]	49 [430]	17 [149]	15 [129]	14 [120]	0,33 [2.7]	1,7 [14.8]
DTR060-050	50:1	19 [165]	16 [143]	15 [134]	49 [430]	17 [153]	15 [133]	14 [124]	0,32 [2.6]	1,7 [14.8]
DTR060-060	60:1	28 [244]	18 [155]	15 [133]	52 [460]	20 [175]	14 [126]	12 [108]	0,42 [3.7]	2,3 [20.2]
DTR060-075	75:1	28 [248]	20 [178]	17 [153]	50 [445]	23 [201]	16 [144]	14 [124]	0,35 [3.0]	2,3 [20.2]
DTR060-090	90:1	28 [244]	20 [175]	17 [150]	52 [460]	22 [198]	16 [142]	14 [122]	0,36 [3.1]	2,3 [20.0]
DTR060-100	100:1	27 [237]	19 [171]	16 [146]	49 [435]	22 [193]	16 [138]	13 [119]	0,41 [3.5]	2,2 [19.9]
DTR060-120	120:1	24 [210]	22 [192]	19 [164]	45 [402]	24 [210]	18 [155]	15 [133]	0,33 [3.0]	2,3 [20.2]
DTR060-125	125:1	29 [257]	23 [207]	20 [178]	51 [455]	27 [235]	19 [168]	16 [144]	0,32 [2.8]	2,4 [21.5]
DTR060-150	150:1	30 [268]	22 [193]	19 [165]	50 [445]	22 [198]	18 [156]	15 [134]	0,35 [2.9]	2,3 [20.1]
DTR060-200	200:1	31 [275]	24 [210]	20 [180]	51 [450]	27 [237]	19 [171]	16 [146]	0,41 [3.4]	2,3 [20.2]
DTR060-250	250:1	32 [279]	25 [224]	22 [193]	51 [455]	29 [254]	21 [182]	18 [156]	0,32 [2.7]	2,4 [21.5]
DTR060-300	300:1	23 [202]	20 [175]	18 [162]	49 [430]	21 [186]	18 [162]	17 [150]	0,35 [2.8]	1,7 [14.8]
DTR060-400	400:1	24 [210]	20 [181]	19 [169]	49 [430]	22 [194]	19 [168]	18 [156]	0,33 [2.7]	1,7 [14.8]
DTR060-500	500:1	24 [215]	21 [186]	20 [175]	49 [430]	23 [199]	20 [173]	18 [162]	0,30 [2.7]	1,7 [14.8]

All ratios are available to ship in 24 hours through the Gearhead Express Program.

<sup>1</sup> Ratios are exact, higher ratios and other custom options are also available, consult factory.

T<sub>r</sub> = Rated output torque at rated speed for specific hours of life.

T<sub>peak</sub> = Allowable momentary peak torque for emergency stop or heavy shock loading.

J = Mass moment of inertia reflected to the input shaft (including pinion assembly).

# Micron TRUE Planetary® Gearheads

## DuraTRUE™ 90 Size 60S (Slim Line)

### Right Angle Gearheads

### Metric

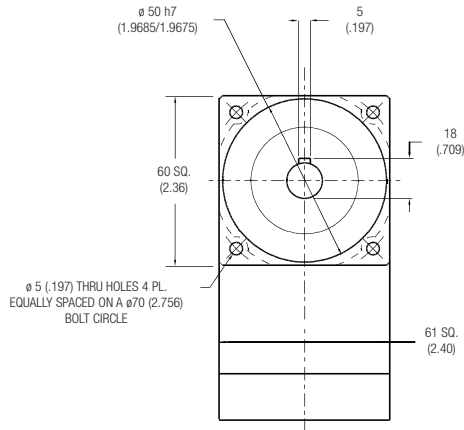
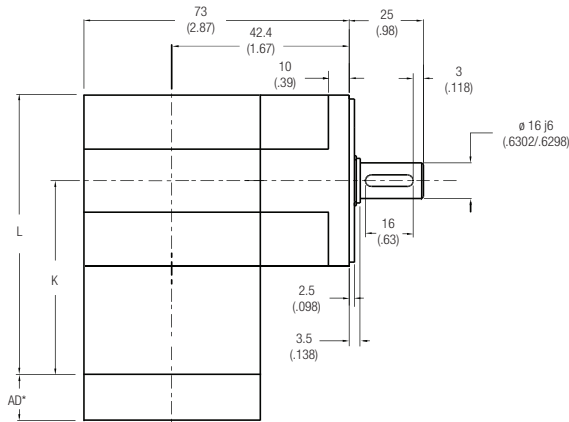

Ratio <sup>1</sup>	Dimension 'K' mm [in.]	Dimension 'L' mm [in.]	Backlash [arc-min]	Weight kg [lb.]	Efficiency
1:1 to 5:1P	79 [3.11]	109,5 [4.31]	8 max	2,3 [5]	98%
5:1T to 50:1	96 [3.79]	127 [4.99]	9 max	2,5 [5.5]	93%
60:1 to 500:1	114 [4.48]	144 [5.68]	9 max	2,7 [6]	88%

All dimensions are: mm (in.)  
 AD\*\* = Adapter length  
 Adapter length will vary depending on motor.  
 Efficiency is calculated at 100% of the rated torque.

## Performance Specifications

Part Number	Ratio <sup>1</sup>	10000 Hour Life			T <sub>peak</sub> Nm [in.-lb.]	20000 Hour Life			J kg-cm <sup>2</sup> [in.-lb.-sec <sup>2</sup> x10 <sup>-4</sup> ]	Torsional Stiffness Nm/arc-min [in.-lb./arc-min]
		T <sub>r</sub> (1000 rpm) Nm [in.-lb.]	T <sub>r</sub> (3000 rpm) Nm [in.-lb.]	T <sub>r</sub> (5000 rpm) Nm [in.-lb.]		T <sub>r</sub> (1000 rpm) Nm [in.-lb.]	T <sub>r</sub> (3000 rpm) Nm [in.-lb.]	T <sub>r</sub> (5000 rpm) Nm [in.-lb.]		
DTR060S-001	1:1	7 [66]	7 [60]	6 [54]	25 [217]	7 [61]	6 [56]	6 [50]	0,79 [7.0]	1,8 [15.8]
DTR060S-002	2:1	16 [145]	15 [132]	14 [120]	45 [400]	15 [134]	14 [122]	12 [111]	0,41 [3.6]	2,7 [23.8]
DTR060S-003	3:1	10 [92]	10 [84]	9 [76]	34 [300]	10 [85]	9 [78]	8 [70]	0,35 [3.1]	3,0 [26.9]
DTR060S-004	4:1	8 [68]	7 [62]	6 [56]	30 [264]	7 [63]	6 [57]	6 [52]	0,32 [2.9]	3,2 [28.2]
DTR060S-005P	5:1P	6 [56]	6 [51]	5 [46]	23 [200]	6 [52]	5 [47]	5 [43]	0,32 [2.8]	3,3 [28.8]
DTR060S-005T	5:1T	23 [200]	18 [162]	16 [138]	46 [407]	21 [182]	15 [132]	13 [112]	0,42 [3.7]	3,3 [28.8]
DTR060S-006	6:1	19 [171]	16 [145]	16 [141]	46 [407]	19 [167]	15 [134]	15 [130]	0,41 [3.7]	2,1 [18.8]
DTR060S-009	9:1	12 [109]	10 [92]	10 [90]	36 [321]	12 [106]	10 [85]	9 [83]	0,35 [3.1]	2,7 [23.7]
DTR060S-010	10:1	20 [176]	18 [160]	16 [145]	46 [407]	20 [174]	17 [154]	15 [134]	0,39 [3.5]	2,1 [18.5]
DTR060S-012	12:1	9 [80]	8 [68]	7 [66]	32 [280]	9 [78]	7 [63]	7 [61]	0,33 [3.0]	3,0 [26.1]
DTR060S-015	15:1	13 [112]	12 [102]	10 [92]	37 [330]	12 [110]	11 [98]	10 [85]	0,33 [2.9]	3,1 [27.4]
DTR060S-020	20:1	9 [82]	8 [75]	8 [68]	46 [407]	9 [81]	8 [72]	7 [63]	0,31 [2.8]	2,9 [26.0]
DTR060S-025	25:1	8 [68]	7 [62]	6 [56]	25 [220]	8 [67]	7 [59]	6 [52]	0,31 [2.7]	3,1 [27.3]
DTR060S-030	30:1	13 [114]	12 [109]	12 [105]	38 [339]	13 [114]	12 [107]	11 [101]	0,32 [2.8]	2,5 [22.4]
DTR060S-040	40:1	10 [84]	9 [81]	9 [77]	33 [292]	9 [84]	9 [79]	8 [74]	0,30 [2.7]	2,8 [25.2]
DTR060S-050	50:1	8 [69]	7 [66]	7 [63]	25 [225]	8 [69]	7 [65]	7 [61]	0,30 [2.6]	3,0 [26.8]
DTR060S-060	60:1	21 [182]	20 [180]	20 [177]	46 [407]	21 [182]	20 [178]	20 [175]	0,42 [3.7]	2,0 [18.1]
DTR060S-075	75:1	13 [116]	13 [114]	13 [112]	39 [345]	13 [115]	13 [113]	12 [110]	0,33 [3.0]	2,6 [23.4]
DTR060S-090	90:1	13 [116]	13 [114]	13 [113]	39 [348]	13 [116]	13 [114]	13 [111]	0,35 [3.1]	2,6 [23.3]
DTR060S-100	100:1	21 [183]	20 [181]	20 [180]	46 [407]	21 [182]	20 [180]	20 [178]	0,40 [3.5]	2,1 [18.3]
DTR060S-120	120:1	10 [85]	10 [84]	9 [83]	34 [300]	10 [85]	9 [84]	9 [82]	0,33 [3.0]	2,9 [25.8]
DTR060S-125	125:1	8 [70]	8 [69]	8 [68]	26 [230]	8 [70]	8 [68]	8 [67]	0,31 [2.8]	3,1 [27.3]
DTR060S-150	150:1	13 [116]	13 [115]	13 [114]	40 [351]	13 [116]	13 [115]	13 [114]	0,33 [2.9]	2,6 [23.4]
DTR060S-200	200:1	21 [183]	21 [182]	21 [181]	46 [407]	21 [183]	21 [182]	20 [181]	0,39 [3.4]	1,9 [17.0]
DTR060S-250	250:1	8 [70]	8 [70]	8 [69]	26 [230]	8 [70]	8 [69]	8 [69]	0,31 [2.7]	3,1 [27.3]
DTR060S-300	300:1	13 [116]	13 [116]	13 [115]	40 [354]	13 [116]	13 [116]	13 [115]	0,32 [2.8]	2,5 [22.4]
DTR060S-400	400:1	10 [86]	10 [85]	10 [85]	34 [304]	10 [86]	10 [85]	10 [85]	0,31 [2.7]	2,8 [25.2]
DTR060S-500	500:1	8 [70]	8 [70]	8 [70]	26 [230]	8 [70]	8 [70]	8 [70]	0,30 [2.7]	3,0 [26.8]

All ratios are available to ship in 24 hours through the Gearhead Express Program.

Ratio 5P is designed using only PowerTRUE face gearing technology.

Ratio 5T adds a True Planetary gearing stage for increased torque capacity.

<sup>1</sup> Ratios are exact, higher ratios and other custom options are also available, consult factory.

T<sub>r</sub> = Rated output torque at rated speed for specific hours of life.

J = Mass moment of inertia reflected to the input shaft (including pinion assembly)

T<sub>peak</sub> = Allowable momentary peak torque for emergency stop or heavy shock loading.



### Right Angle Gearheads

Metric

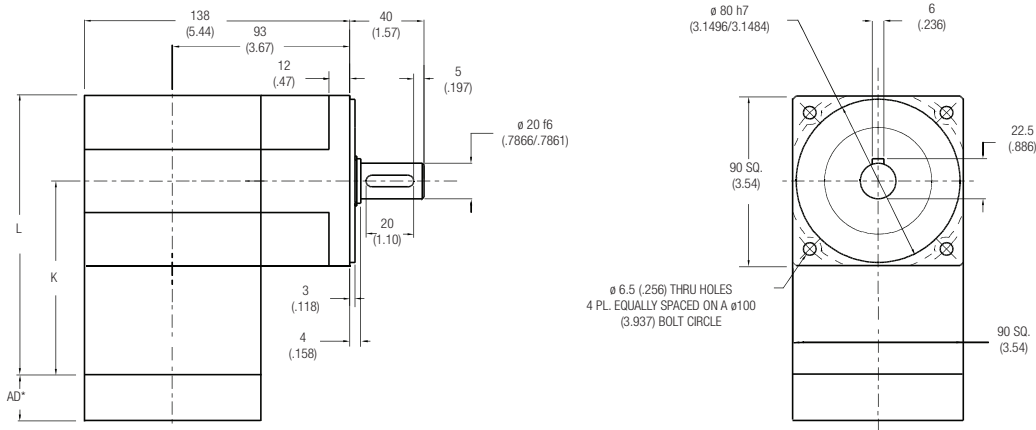

Ratio <sup>1</sup>	Dimension 'K' mm [in.]	Dimension 'L' mm [in.]	Backlash [arc-min]	Weight kg [lb.]	Efficiency
5:1 to 50:1	101 [3.99]	146 [5.76]	9 max	4,8 [10]	93%
60:1 to 500:1	124 [4.89]	169 [6.66]	9 max	5,5 [12]	88%

All dimensions are: mm (in.)

AD\*\* = Adapter length

Adapter length will vary depending on motor.

Efficiency is calculated at 100% of the rated torque.

### Performance Specifications

Part Number	Ratio <sup>1</sup>	10000 Hour Life			T <sub>peak</sub> Nm [in.-lb.]	20000 Hour Life			J kg-cm <sup>2</sup> [in.-lb.-sec <sup>2</sup> x10 <sup>-4</sup> ]	Torsional Stiffness Nm/arc-min [in.-lb./arc-min]
		T <sub>r</sub> (1000 rpm) Nm [in.-lb.]	T <sub>r</sub> (3000 rpm) Nm [in.-lb.]	T <sub>r</sub> (5000 rpm) Nm [in.-lb.]		T <sub>r</sub> (1000 rpm) Nm [in.-lb.]	T <sub>r</sub> (3000 rpm) Nm [in.-lb.]	T <sub>r</sub> (5000 rpm) Nm [in.-lb.]		
DTR090-005	5:1	79 [702]	58 [515]	50 [442]	167 [1479]	66 [582]	47 [418]	41 [359]	1,64 [14.5]	7,8 [69.2]
DTR090-006	6:1	82 [722]	61 [544]	53 [467]	167 [1479]	69 [614]	50 [442]	43 [379]	1,63 [14.4]	5,5 [48.2]
DTR090-009	9:1	75 [665]	69 [614]	60 [527]	167 [1479]	75 [665]	56 [499]	48 [428]	1,39 [12.3]	5,5 [48.8]
DTR090-010	10:1	79 [703]	68 [599]	58 [514]	167 [1479]	76 [676]	55 [486]	47 [417]	1,62 [14.3]	5,5 [48.4]
DTR090-012	12:1	57 [509]	57 [509]	57 [509]	144 [1272]	57 [509]	57 [509]	53 [467]	1,29 [11.4]	5,5 [49.0]
DTR090-015	15:1	82 [723]	75 [664]	66 [580]	167 [1479]	80 [707]	62 [549]	53 [471]	1,26 [11.1]	5,5 [49.0]
DTR090-020	20:1	83 [737]	77 [681]	72 [633]	167 [1479]	81 [720]	68 [599]	58 [514]	1,28 [11.3]	5,5 [48.7]
DTR090-025	25:1	71 [624]	71 [624]	71 [624]	167 [1479]	71 [624]	71 [624]	62 [549]	1,26 [11.1]	5,5 [48.7]
DTR090-030	30:1	64 [568]	55 [488]	51 [452]	167 [1479]	59 [526]	51 [452]	47 [418]	1,38 [12.2]	4,0 [35.6]
DTR090-040	40:1	67 [590]	58 [509]	53 [472]	167 [1479]	62 [546]	53 [471]	49 [437]	1,28 [11.3]	4,0 [35.6]
DTR090-050	50:1	69 [608]	59 [525]	55 [488]	167 [1479]	63 [562]	55 [486]	51 [452]	1,25 [11.1]	4,0 [35.6]
DTR090-060	60:1	106 [941]	80 [709]	69 [608]	167 [1479]	90 [800]	65 [576]	56 [494]	1,63 [14.4]	5,5 [48.6]
DTR090-075	75:1	98 [870]	90 [799]	79 [698]	167 [1479]	96 [851]	75 [661]	64 [567]	1,39 [12.3]	5,5 [48.4]
DTR090-090	90:1	98 [866]	90 [800]	78 [687]	167 [1479]	98 [866]	73 [650]	63 [558]	1,39 [12.3]	5,4 [48.0]
DTR090-100	100:1	103 [916]	88 [780]	76 [670]	167 [1479]	100 [881]	72 [633]	61 [543]	1,62 [14.3]	5,4 [47.8]
DTR090-120	120:1	75 [663]	75 [663]	75 [663]	144 [1272]	75 [663]	75 [663]	69 [608]	1,29 [11.4]	5,5 [48.5]
DTR090-125	125:1	85 [751]	85 [751]	85 [751]	167 [1479]	85 [751]	85 [751]	75 [661]	1,26 [11.1]	5,8 [51.6]
DTR090-150	150:1	106 [942]	98 [865]	85 [756]	167 [1479]	98 [866]	81 [715]	69 [614]	1,39 [12.3]	5,5 [48.3]
DTR090-200	200:1	109 [960]	100 [887]	93 [825]	167 [1479]	108 [938]	88 [780]	76 [670]	1,61 [14.2]	5,5 [48.5]
DTR090-250	250:1	92 [813]	92 [813]	92 [813]	167 [1479]	92 [813]	92 [813]	81 [715]	1,26 [11.1]	5,8 [51.5]
DTR090-300	300:1	84 [740]	72 [636]	67 [589]	167 [1479]	77 [685]	67 [589]	62 [545]	1,38 [12.2]	4,0 [35.5]
DTR090-400	400:1	87 [769]	75 [663]	69 [615]	167 [1479]	80 [711]	69 [614]	64 [569]	1,28 [11.3]	4,0 [35.5]
DTR090-500	500:1	90 [792]	77 [684]	72 [636]	167 [1479]	83 [732]	72 [633]	67 [589]	1,20 [10.6]	4,0 [35.6]

All ratios are available to ship in 24 hours through the Gearhead Express Program.

<sup>1</sup> Ratios are exact, higher ratios and other custom options are also available, consult factory.

T<sub>r</sub> = Rated output torque at rated speed for specific hours of life.

T<sub>peak</sub> = Allowable momentary peak torque for emergency stop or heavy shock loading.  
J = Mass moment of inertia reflected to the input shaft (including pinion assembly).

# Micron TRUE Planetary® Gearheads

## DuraTRUE™ 90 Size 60S (Slim Line)

### Right Angle Gearheads

Metric

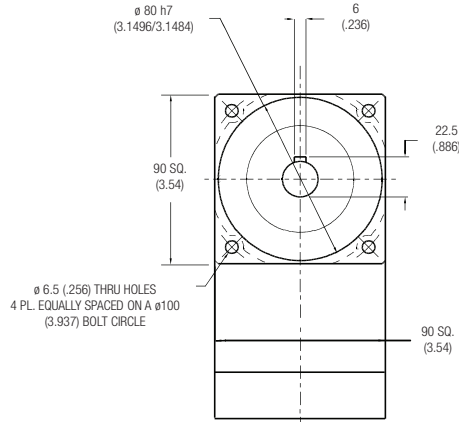
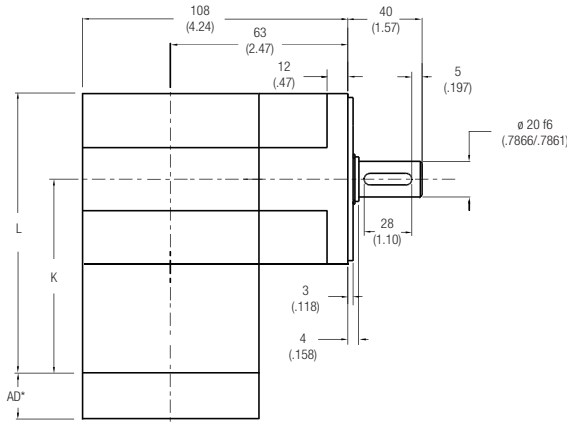

Ratio <sup>1</sup>	Dimension 'K' mm [in.]	Dimension 'L' mm [in.]	Backlash [arc-min]	Weight kg [lb.]	Efficiency
1:1 to 5:1P	101 [3.99]	146 [5.76]	8 max	4,1 [9]	98%
5:1T to 50:1	124 [4.89]	169 [6.66]	9 max	4,8 [10]	93%
60:1 to 500:1	114 [5.79]	192 [7.56]	9 max	5,5 [12]	88%

All dimensions are: mm (in.)  
AD\*\* = Adapter length  
Adapter length will vary depending on motor.  
Efficiency is calculated at 100% of the rated torque.

### Performance Specifications

Part Number	Ratio <sup>1</sup>	10000 Hour Life			T <sub>peak</sub> Nm [in.-lb.]	20000 Hour Life			J kg-cm <sup>2</sup> [in.-lb.-sec <sup>2</sup> x10 <sup>-4</sup> ]	Torsional Stiffness Nm/arc-min [in.-lb./arc-min]
		T <sub>r</sub> (1000 rpm) Nm [in.-lb.]	T <sub>r</sub> (3000 rpm) Nm [in.-lb.]	T <sub>r</sub> (5000 rpm) Nm [in.-lb.]		T <sub>r</sub> (1000 rpm) Nm [in.-lb.]	T <sub>r</sub> (3000 rpm) Nm [in.-lb.]	T <sub>r</sub> (5000 rpm) Nm [in.-lb.]		
DTR090S-001	1:1	21 [188]	19 [171]	17 [155]	62 [548]	20 [173]	18 [158]	16 [143]	3,11 [27.5]	4,3 [37.9]
DTR090S-002	2:1	48 [426]	44 [389]	40 [352]	140 [1237]	44 [394]	41 [359]	37 [325]	1,59 [14.1]	6,5 [57.2]
DTR090S-003	3:1	32 [281]	29 [256]	26 [232]	114 [1005]	29 [260]	27 [237]	24 [214]	1,37 [12.1]	7,3 [64.6]
DTR090S-004	4:1	24 [215]	22 [196]	20 [177]	87 [772]	22 [199]	20 [181]	19 [164]	1,27 [11.2]	7,6 [67.7]
DTR090S-005P	5:1P	18 [158]	16 [144]	15 [131]	73 [645]	17 [146]	15 [133]	14 [121]	1,25 [11.0]	7,8 [69.2]
DTR090S-005T	5:1T	64 [568]	55 [483]	53 [469]	140 [1237]	63 [556]	50 [446]	49 [433]	1,64 [14.5]	5,1 [45.1]
DTR090S-006	6:1	57 [501]	48 [426]	47 [414]	140 [1237]	55 [490]	44 [394]	43 [382]	1,63 [14.4]	5,1 [45.1]
DTR090S-009	9:1	37 [331]	32 [281]	31 [273]	124 [1095]	37 [323]	29 [260]	28 [252]	1,37 [12.1]	6,4 [56.9]
DTR090S-010	10:1	58 [516]	53 [471]	48 [426]	140 [1237]	58 [510]	51 [452]	44 [394]	1,54 [13.7]	5,0 [44.5]
DTR090S-012	12:1	29 [253]	24 [215]	24 [209]	94 [836]	28 [247]	22 [199]	22 [193]	1,31 [11.6]	7,1 [62.7]
DTR090S-015	15:1	38 [340]	35 [311]	32 [281]	128 [1131]	38 [336]	34 [298]	29 [260]	1,28 [11.3]	7,4 [65.8]
DTR090S-020	20:1	29 [261]	27 [238]	24 [215]	140 [1237]	29 [257]	26 [228]	22 [199]	1,22 [10.8]	7,1 [62.4]
DTR090S-025	25:1	22 [192]	20 [175]	18 [158]	80 [705]	21 [189]	19 [168]	17 [146]	1,20 [10.6]	7,4 [65.6]
DTR090S-030	30:1	39 [348]	38 [333]	36 [318]	131 [1161]	39 [346]	37 [327]	35 [307]	1,25 [11.1]	6,1 [53.8]
DTR090S-040	40:1	30 [266]	29 [255]	28 [243]	99 [880]	30 [265]	28 [250]	27 [235]	1,19 [10.6]	6,8 [60.5]
DTR090S-050	50:1	22 [196]	21 [188]	20 [179]	82 [725]	22 [195]	21 [184]	20 [173]	1,17 [10.4]	7,3 [64.2]
DTR090S-060	60:1	60 [535]	60 [527]	59 [520]	140 [1237]	60 [534]	59 [524]	58 [514]	1,63 [14.4]	4,9 [43.5]
DTR090S-075	75:1	40 [352]	39 [346]	38 [340]	136 [1200]	40 [351]	39 [344]	38 [336]	1,31 [11.6]	6,4 [56.2]
DTR090S-090	90:1	40 [353]	39 [348]	39 [343]	136 [1206]	40 [352]	39 [346]	38 [339]	1,37 [12.1]	6,3 [55.8]
DTR090S-100	100:1	61 [536]	60 [532]	60 [527]	140 [1237]	61 [536]	60 [530]	59 [524]	1,55 [13.7]	5,0 [43.9]
DTR090S-120	120:1	31 [270]	30 [266]	30 [262]	103 [908]	30 [269]	30 [265]	29 [260]	1,31 [11.6]	7,0 [62.0]
DTR090S-125	125:1	22 [198]	22 [195]	22 [192]	84 [740]	22 [198]	22 [194]	21 [189]	1,23 [10.8]	7,4 [65.5]
DTR090S-150	150:1	40 [354]	40 [351]	39 [348]	138 [1218]	40 [353]	39 [350]	39 [346]	1,29 [11.4]	6,3 [56.1]
DTR090S-200	200:1	61 [538]	60 [535]	60 [533]	140 [1237]	61 [537]	60 [534]	60 [531]	1,52 [13.5]	4,6 [40.7]
DTR090S-250	250:1	23 [199]	22 [198]	22 [196]	85 [750]	22 [199]	22 [197]	22 [195]	1,21 [10.7]	7,4 [65.4]
DTR090S-300	300:1	40 [355]	40 [353]	40 [352]	139 [1230]	40 [354]	40 [352]	40 [350]	1,26 [11.1]	6,1 [53.7]
DTR090S-400	400:1	31 [271]	31 [270]	30 [269]	104 [924]	31 [271]	30 [270]	30 [268]	1,20 [10.6]	6,8 [60.5]
DTR090S-500	500:1	23 [200]	22 [199]	22 [198]	85 [755]	23 [200]	22 [198]	22 [197]	1,18 [10.4]	7,3 [64.2]

All ratios are available to ship in 24 hours through the Gearhead Express Program.

Ratio 5P is designed using only PowerTRUE face gearing technology.

Ratio 5T adds a True Planetary gearing stage for increased torque capacity.

<sup>1</sup> Ratios are exact, higher ratios and other custom options are also available, consult factory.

T<sub>r</sub> = Rated output torque at rated speed for specific hours of life.

J = Mass moment of inertia reflected to the input shaft (including pinion assembly)

T<sub>peak</sub> = Allowable momentary peak torque for emergency stop or heavy shock loading.

### Right Angle Gearheads

Metric

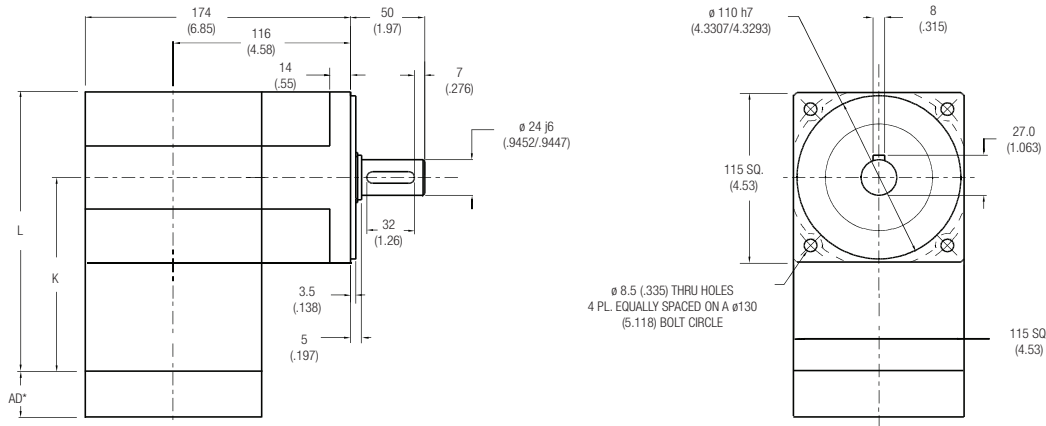

Ratio <sup>1</sup>	Dimension 'K' mm [in.]	Dimension 'L' mm [in.]	Backlash [arc-min]	Weight kg [lb.]	Efficiency
5:1 to 50:1	137 [5.40]	195 [7.67]	8 max	11 [24]	93%
60:1 to 500:1	168,4 [6.63]	226 [8.90]	9 max	12 [27]	88%

All dimensions are: mm (in.)

AD\*\* = Adapter length

Adapter length will vary depending on motor. Efficiency is calculated at 100% of the rated torque.

### Performance Specifications

Part Number	Ratio <sup>1</sup>	10000 Hour Life			T <sub>peak</sub> Nm [in.-lb.]	20000 Hour Life			J kg-cm <sup>2</sup> [in.-lb.-sec <sup>2</sup> ×10 <sup>-4</sup> ]	Torsional Stiffness Nm/arc-min [in.-lb./arc-min]
		T <sub>r</sub> (1000 rpm) Nm [in.-lb.]	T <sub>r</sub> (3000 rpm) Nm [in.-lb.]	T <sub>r</sub> (5000 rpm) Nm [in.-lb.]		T <sub>r</sub> (1000 rpm) Nm [in.-lb.]	T <sub>r</sub> (3000 rpm) Nm [in.-lb.]	T <sub>r</sub> (5000 rpm) Nm [in.-lb.]		
DTR115-005	5:1	123 [1086]	88 [781]	76 [670]	284 [2511]	100 [882]	72 [634]	61 [544]	2,79 [24.7]	15,3 [135]
DTR115-006	6:1	130 [1147]	93 [825]	80 [708]	284 [2511]	105 [932]	76 [670]	65 [575]	2,77 [24.5]	12,5 [110]
DTR115-009	9:1	146 [1295]	105 [932]	90 [799]	284 [2511]	119 [1052]	86 [757]	73 [649]	2,37 [21.0]	12,6 [112]
DTR115-010	10:1	143 [1262]	103 [908]	88 [779]	284 [2511]	116 [1025]	83 [738]	72 [633]	2,75 [24.3]	13,1 [116]
DTR115-012	12:1	137 [1210]	115 [1016]	98 [871]	284 [2511]	130 [1147]	93 [825]	80 [708]	2,19 [19.4]	12,7 [112]
DTR115-015	15:1	161 [1425]	116 [1025]	99 [880]	284 [2511]	131 [1158]	94 [833]	81 [715]	2,14 [18.9]	12,7 [112]
DTR115-020	20:1	164 [1453]	126 [1118]	108 [959]	284 [2511]	143 [1262]	103 [908]	88 [779]	2,18 [19.3]	13,2 [117]
DTR115-025	25:1	167 [1474]	135 [1195]	116 [1025]	284 [2511]	153 [1350]	110 [971]	94 [833]	2,14 [18.9]	13,2 [117]
DTR115-030	30:1	105 [930]	90 [796]	83 [736]	284 [2511]	97 [861]	83 [737]	77 [681]	2,34 [20.7]	11,5 [102]
DTR115-040	40:1	109 [967]	94 [831]	87 [770]	284 [2511]	101 [894]	87 [769]	80 [712]	2,17 [19.2]	11,5 [102]
DTR115-050	50:1	112 [995]	97 [858]	90 [796]	284 [2511]	104 [921]	90 [794]	83 [737]	2,13 [18.8]	11,5 [102]
DTR115-060	60:1	169 [1495]	121 [1075]	104 [923]	284 [2511]	137 [1214]	99 [873]	85 [749]	2,77 [24.5]	13,2 [117]
DTR115-075	75:1	194 [1715]	139 [1233]	120 [1059]	284 [2511]	139 [1233]	113 [1002]	97 [860]	2,35 [20.8]	13,1 [116]
DTR115-090	90:1	191 [1687]	137 [1214]	118 [1041]	284 [2511]	155 [1371]	111 [986]	96 [846]	2,37 [21.0]	12,5 [110]
DTR115-100	100:1	186 [1644]	134 [1183]	115 [1015]	284 [2511]	151 [1336]	109 [962]	93 [825]	2,75 [24.3]	13,0 [115]
DTR115-120	120:1	178 [1577]	150 [1324]	128 [1135]	284 [2511]	169 [1495]	121 [1075]	104 [923]	2,19 [19.4]	12,6 [111]
DTR115-125	125:1	200 [1774]	162 [1438]	139 [1233]	284 [2511]	184 [1624]	132 [1168]	113 [1002]	2,14 [18.9]	13,2 [117]
DTR115-150	150:1	210 [1857]	151 [1336]	130 [1147]	284 [2511]	170 [1509]	123 [1085]	105 [932]	2,35 [20.8]	13,1 [116]
DTR115-200	200:1	214 [1893]	165 [1457]	141 [1250]	284 [2511]	186 [1644]	134 [1183]	115 [1015]	2,73 [24.2]	13,2 [116]
DTR115-250	250:1	217 [1921]	176 [1557]	151 [1336]	284 [2511]	199 [1759]	143 [1265]	123 [1085]	2,14 [18.9]	13,2 [117]
DTR115-300	300:1	137 [1212]	117 [1037]	108 [959]	284 [2511]	127 [1122]	109 [960]	100 [887]	2,34 [20.7]	11,5 [102]
DTR115-400	400:1	142 [1260]	122 [1083]	113 [1003]	284 [2511]	132 [1165]	113 [1002]	105 [928]	2,17 [19.2]	11,5 [102]
DTR115-500	500:1	146 [1296]	126 [1118]	117 [1037]	284 [2511]	136 [1200]	117 [1035]	109 [960]	2,03 [18.0]	11,5 [102]

All ratios are available to ship in 24 hours through the Gearhead Express Program.

<sup>1</sup> Ratios are exact, higher ratios and other custom options are also available, consult factory.

T<sub>r</sub> = Rated output torque at rated speed for specific hours of life.

T<sub>peak</sub> = Allowable momentary peak torque for emergency stop or heavy shock loading.  
J = Mass moment of inertia reflected to the input shaft (including pinion assembly).

# Micron TRUE Planetary® Gearheads

## DuraTRUE™ 90 Size 115S (Slim Line)

### Right Angle Gearheads

### Metric

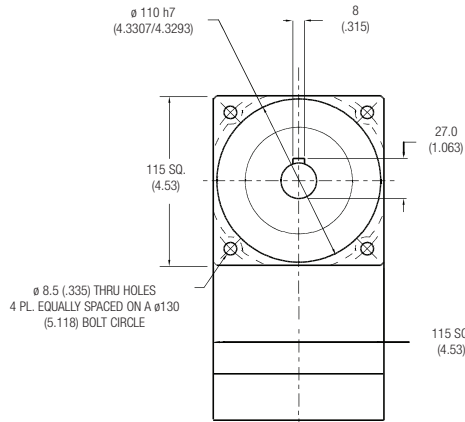
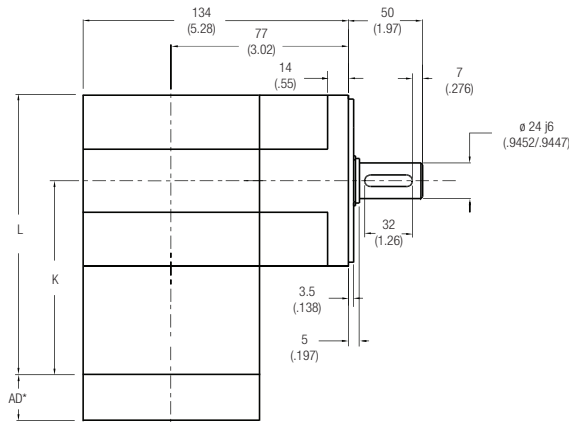

Ratio <sup>1</sup>	Dimension 'K' mm [in.]	Dimension 'L' mm [in.]	Backlash [arc-min]	Weight kg [lb.]	Efficiency
1:1 to 5:1P	137 [5.40]	195 [7.67]	8 max	9 [20]	98%
5:1T to 50:1	168,4 [6.63]	226 [8.90]	9 max	11 [24]	93%
60:1 to 500:1	200 [7.87]	257 [10.13]	9 max	12 [27]	88%

All dimensions are: mm (in.)

AD\*\* = Adapter length

Adapter length will vary depending on motor. Efficiency is calculated at 100% of the rated torque.

## Performance Specifications

Part Number	Ratio <sup>1</sup>	10000 Hour Life			T <sub>peak</sub> Nm [in.-lb.]	20000 Hour Life			J kg-cm <sup>2</sup> [in.-lb.- sec <sup>2</sup> x10 <sup>-4</sup> ]	Torsional Stiffness Nm/arc-min [in.-lb./arc-min]
		T <sub>r</sub> (1000 rpm) Nm [in.-lb.]	T <sub>r</sub> (3000 rpm) Nm [in.-lb.]	T <sub>r</sub> (5000 rpm) Nm [in.-lb.]		T <sub>r</sub> (1000 rpm) Nm [in.-lb.]	T <sub>r</sub> (3000 rpm) Nm [in.-lb.]	T <sub>r</sub> (5000 rpm) Nm [in.-lb.]		
DTR115S-001	1:1	63 [554]	57 [506]	52 [457]	203 [1800]	58 [512]	53 [467]	48 [422]	5,28 [46.7]	7,6 [67.6]
DTR115S-002	2:1	112 [989]	102 [903]	92 [816]	283 [2505]	103 [913]	94 [834]	85 [754]	2,71 [23.9]	12,5 [111]
DTR115S-003	3:1	87 [768]	79 [701]	72 [634]	256 [2265]	80 [709]	73 [647]	66 [585]	2,33 [20.6]	14,2 [126]
DTR115S-004	4:1	58 [511]	53 [467]	48 [422]	199 [1760]	53 [472]	49 [431]	44 [390]	2,16 [19.1]	14,9 [132]
DTR115S-005P	5:1P	43 [384]	40 [350]	36 [316]	164 [1450]	40 [354]	37 [323]	33 [292]	2,12 [18.8]	15,3 [135]
DTR115S-005T	5:1T	170 [1505]	126 [1117]	108 [958]	283 [2505]	143 [1262]	102 [907]	88 [778]	2,78 [24.6]	15,3 [135]
DTR115S-006	6:1	131 [1163]	112 [989]	109 [960]	283 [2505]	129 [1138]	103 [913]	100 [887]	2,77 [24.5]	10,2 [90.7]
DTR115S-009	9:1	102 [903]	87 [768]	84 [746]	281 [2490]	100 [884]	80 [709]	78 [689]	2,32 [20.5]	12,8 [113]
DTR115S-010	10:1	135 [1198]	124 [1094]	112 [989]	283 [2505]	134 [1183]	118 [1048]	103 [913]	2,63 [23.2]	10,2 [90.3]
DTR115S-012	12:1	68 [601]	58 [511]	56 [496]	217 [1920]	66 [588]	53 [472]	52 [458]	2,22 [19.6]	14,0 [124]
DTR115S-015	15:1	105 [930]	96 [849]	87 [768]	283 [2505]	104 [919]	92 [814]	80 [709]	2,18 [19.3]	14,6 [130]
DTR115S-020	20:1	70 [619]	64 [565]	58 [511]	283 [2505]	69 [612]	61 [542]	53 [472]	2,08 [18.4]	14,0 [124]
DTR115S-025	25:1	52 [465]	48 [424]	43 [384]	183 [1620]	52 [459]	46 [406]	40 [354]	2,04 [18.0]	14,6 [129]
DTR115S-030	30:1	107 [951]	103 [910]	98 [869]	283 [2505]	107 [945]	101 [892]	95 [840]	2,13 [18.9]	12,5 [111]
DTR115S-040	40:1	72 [633]	68 [606]	65 [579]	231 [2040]	71 [629]	67 [594]	63 [559]	2,03 [18.0]	13,8 [122]
DTR115S-050	50:1	54 [475]	51 [454]	49 [434]	188 [1665]	53 [472]	50 [446]	47 [419]	1,99 [17.6]	14,5 [128]
DTR115S-060	60:1	140 [1242]	138 [1224]	136 [1207]	283 [2505]	140 [1239]	137 [1217]	135 [1194]	2,78 [24.6]	10,0 [88.5]
DTR115S-075	75:1	109 [963]	107 [947]	105 [930]	283 [2505]	109 [960]	106 [939]	104 [919]	2,22 [19.7]	12,7 [112]
DTR115S-090	90:1	109 [964]	107 [951]	106 [937]	283 [2505]	109 [962]	107 [945]	105 [927]	2,33 [20.6]	12,6 [112]
DTR115S-100	100:1	141 [1245]	140 [1235]	138 [1224]	283 [2505]	141 [1244]	139 [1230]	137 [1217]	2,64 [23.3]	10,1 [89.5]
DTR115S-120	120:1	73 [642]	72 [633]	70 [624]	238 [2108]	72 [641]	71 [629]	70 [617]	2,23 [19.7]	13,9 [123]
DTR115S-125	125:1	54 [481]	53 [473]	52 [465]	193 [1710]	54 [480]	53 [469]	52 [459]	2,08 [18.4]	14,6 [129]
DTR115S-150	150:1	109 [967]	108 [959]	107 [951]	283 [2505]	109 [966]	108 [955]	107 [945]	2,19 [19.4]	12,7 [112]
DTR115S-200	200:1	141 [1248]	140 [1243]	140 [1237]	283 [2505]	141 [1247]	140 [1240]	139 [1234]	2,59 [22.9]	9,8 [87.1]
DTR115S-250	250:1	55 [483]	54 [479]	54 [475]	196 [1735]	54 [482]	54 [477]	53 [472]	2,05 [18.1]	14,6 [129]
DTR115S-300	300:1	109 [969]	109 [965]	109 [961]	283 [2505]	109 [968]	109 [963]	108 [958]	2,14 [18.9]	12,5 [111]
DTR115S-400	400:1	73 [645]	73 [642]	72 [640]	244 [2160]	73 [645]	72 [641]	72 [638]	2,04 [18.1]	13,8 [122]
DTR115S-500	500:1	55 [484]	54 [482]	54 [480]	198 [1755]	55 [483]	54 [481]	54 [478]	2,00 [17.7]	14,5 [128]

All ratios are available to ship in 24 hours through the Gearhead Express Program.

Ratio 5P is designed using only PowerTRUE face gearing technology.

Ratio 5T adds a True Planetary gearing stage for increased torque capacity.

<sup>1</sup> Ratios are exact, higher ratios and other custom options are also available, consult factory.

T<sub>r</sub> = Rated output torque at rated speed for specific hours of life.

J = Mass moment of inertia reflected to the input shaft (including pinion assembly)

T<sub>peak</sub> = Allowable momentary peak torque for emergency stop or heavy shock loading.

### Right Angle Gearheads

Metric

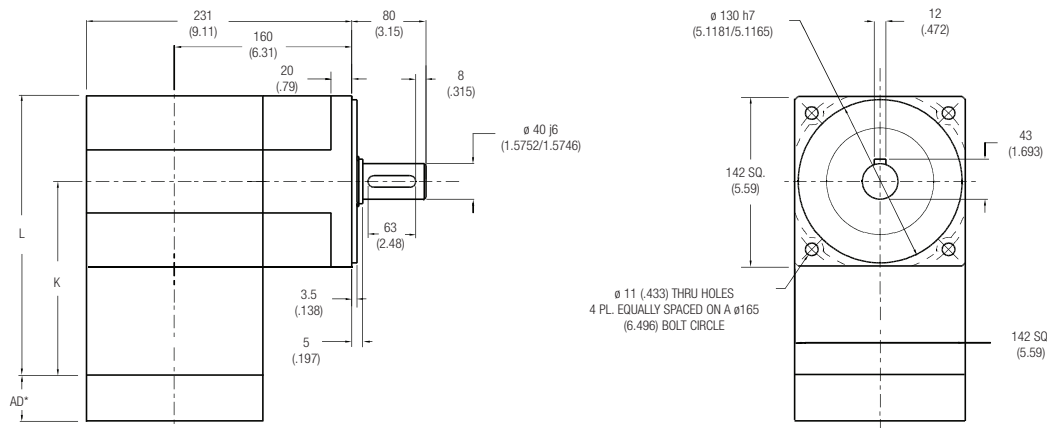

Ratio <sup>1</sup>	Dimension 'K' mm [in.]	Dimension 'L' mm [in.]	Backlash [arc-min]	Weight kg [lb.]	Efficiency
6:1 to 50:1	160 [6.29]	231 [9.09]	9 max	24 [53]	93%
60:1 to 500:1	209 [8.23]	280 [11.03]	9 max	28 [62]	88%

All dimensions are: mm (in.)  
 AD\*\* = Adapter length  
 Adapter length will vary depending on motor. Efficiency is calculated at 100% of the rated torque.

### Performance Specifications

Part Number	Ratio <sup>1</sup>	10000 Hour Life			T <sub>peak</sub> Nm [in.-lb.]	20000 Hour Life			J kg-cm <sup>2</sup> [in.-lb.-sec <sup>2</sup> ×10 <sup>-4</sup> ]	Torsional Stiffness Nm/arc-min [in.-lb./arc-min]
		T <sub>r</sub> (1000 rpm) Nm [in.-lb.]	T <sub>r</sub> (3000 rpm) Nm [in.-lb.]	T <sub>r</sub> (5000 rpm) Nm [in.-lb.]		T <sub>r</sub> (1000 rpm) Nm [in.-lb.]	T <sub>r</sub> (3000 rpm) Nm [in.-lb.]	T <sub>r</sub> (5000 rpm) Nm [in.-lb.]		
DTR142-006	6:1	454 [4020]	329 [2912]	282 [2498]	833 [7377]	372 [3289]	267 [2365]	229 [2029]	13,8 [122]	38,6 [342]
DTR142-009	9:1	444 [3934]	372 [3289]	319 [2821]	833 [7377]	420 [3714]	302 [2671]	259 [2292]	11,8 [104]	39,1 [346]
DTR142-010	10:1	448 [3965]	363 [3210]	311 [2754]	833 [7377]	410 [3625]	295 [2607]	253 [2237]	13,7 [121]	40,6 [360]
DTR142-012	12:1	319 [2825]	319 [2825]	319 [2825]	798 [7062]	319 [2825]	319 [2825]	282 [2498]	10,9 [96.3]	39,3 [348]
DTR142-015	15:1	463 [4096]	410 [3625]	351 [3110]	833 [7377]	453 [4005]	333 [2944]	285 [2526]	10,7 [94.2]	39,4 [349]
DTR142-020	20:1	473 [4183]	432 [3824]	383 [3390]	833 [7377]	462 [4090]	363 [3210]	311 [2754]	10,8 [95.9]	40,9 [362]
DTR142-025	25:1	399 [3532]	399 [3532]	399 [3532]	833 [7377]	399 [3532]	388 [3432]	333 [2944]	10,6 [94.0]	40,9 [362]
DTR142-030	30:1	268 [2373]	228 [2022]	134 [1185]	833 [7377]	248 [2196]	211 [1871]	195 [1724]	11,7 [103]	35,6 [315]
DTR142-040	40:1	279 [2468]	240 [2122]	221 [1952]	833 [7377]	258 [2284]	221 [1955]	204 [1807]	10,8 [95.5]	35,6 [315]
DTR142-050	50:1	287 [2543]	247 [2183]	228 [2022]	833 [7377]	266 [2353]	228 [2020]	211 [1871]	10,6 [93.7]	35,6 [315]
DTR142-060	60:1	592 [5238]	429 [3794]	368 [3255]	833 [7377]	486 [4297]	348 [3082]	299 [2644]	13,8 [122]	40,8 [361]
DTR142-075	75:1	557 [4928]	493 [4362]	423 [3742]	833 [7377]	544 [4819]	400 [3542]	343 [3039]	11,7 [104]	40,6 [360]
DTR142-090	90:1	579 [5126]	484 [4286]	415 [3676]	833 [7377]	547 [4839]	393 [3480]	337 [2986]	11,8 [104]	38,6 [342]
DTR142-100	100:1	584 [5166]	473 [4183]	405 [3588]	833 [7377]	534 [4723]	384 [3397]	329 [2915]	13,7 [121]	40,2 [356]
DTR142-120	120:1	416 [3681]	416 [3681]	416 [3681]	798 [7062]	416 [3681]	416 [3681]	368 [3255]	10,9 [96.3]	39,0 [345]
DTR142-125	125:1	480 [4250]	480 [4250]	480 [4250]	833 [7377]	480 [4250]	467 [4129]	400 [3542]	10,6 [94.0]	40,9 [362]
DTR142-150	150:1	603 [5337]	534 [4723]	458 [4052]	833 [7377]	590 [5218]	433 [3836]	372 [3291]	11,7 [104]	40,6 [360]
DTR142-200	200:1	616 [5450]	563 [4983]	499 [4417]	833 [7377]	602 [5329]	473 [4183]	405 [3588]	13,6 [120]	40,8 [361]
DTR142-250	250:1	520 [4602]	520 [4602]	520 [4602]	833 [7377]	520 [4602]	505 [4472]	433 [3836]	10,6 [94.0]	40,9 [362]
DTR142-300	300:1	349 [3092]	298 [2635]	174 [1544]	833 [7377]	323 [2861]	275 [2438]	254 [2246]	11,7 [103]	35,6 [315]
DTR142-400	400:1	363 [3216]	312 [2765]	287 [2543]	833 [7377]	336 [2976]	288 [2547]	266 [2355]	10,8 [95.5]	35,6 [315]
DTR142-500	500:1	374 [3314]	321 [2844]	298 [2635]	833 [7377]	346 [3066]	297 [2632]	275 [2438]	10,1 [89.4]	35,6 [315]

All ratios are available to ship in 24 hours through the Gearhead Express Program.

<sup>1</sup> Ratios are exact, higher ratios and other custom options are also available, consult factory.  
 T<sub>r</sub> = Rated output torque at rated speed for specific hours of life.

T<sub>peak</sub> = Allowable momentary peak torque for emergency stop or heavy shock loading  
 J = Mass moment of inertia reflected to the input shaft (including pinion assembly).

# Micron TRUE Planetary® Gearheads

## DuraTRUE™ 90 Size 142S (Slim Line)

### Right Angle Gearheads

Metric

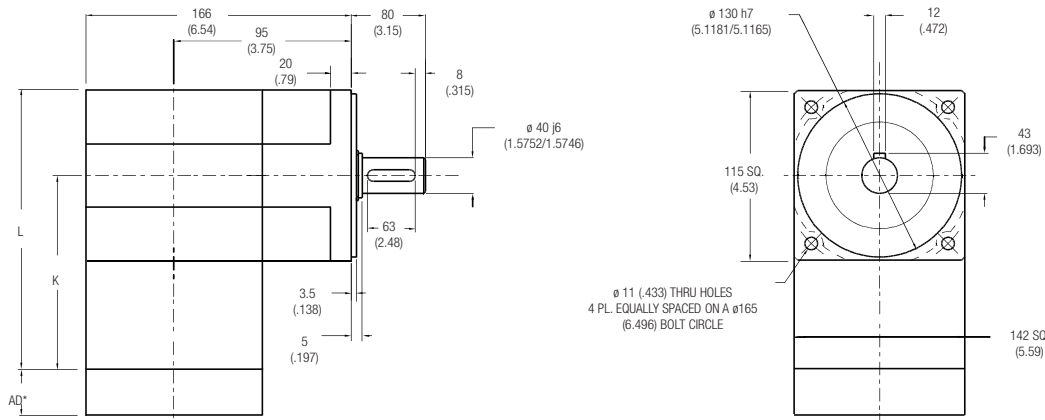

Ratio <sup>1</sup>	Dimension 'K' mm [in.]	Dimension 'L' mm [in.]	Backlash [arc-min]	Weight kg [lb.]	Efficiency
1:1 to 5:1P	160 [6.29]	231 [9.09]	8 max	19 [43]	98%
6:1 to 50:1	209 [8.23]	280 [11.03]	9 max	24 [53]	93%
60:1 to 500:1	259 [10.18]	329 [12.97]	9 max	28 [62]	88%

All dimensions are: mm (in.)  
AD\*\* = Adapter length  
Adapter length will vary depending on motor.  
Efficiency is calculated at 100% of the rated torque.

### Performance Specifications

Part Number	Ratio <sup>1</sup>	10000 Hour Life			T <sub>peak</sub> Nm [in.-lb.]	20000 Hour Life			J kg-cm <sup>2</sup> [in.-lb.-sec <sup>2</sup> ×10 <sup>-4</sup> ]	Torsional Stiffness Nm/arc-min [in.-lb./arc-min]
		T <sub>r</sub> (1000 rpm) Nm [in.-lb.]	T <sub>r</sub> (3000 rpm) Nm [in.-lb.]	T <sub>r</sub> (5000 rpm) Nm [in.-lb.]		T <sub>r</sub> (1000 rpm) Nm [in.-lb.]	T <sub>r</sub> (3000 rpm) Nm [in.-lb.]	T <sub>r</sub> (5000 rpm) Nm [in.-lb.]		
DTR142S-001	1:1	135 [1194]	123 [1090]	111 [985]	333 [2950]	125 [1103]	114 [1006]	103 [910]	26,3 [232]	23,7 [210]
DTR142S-002	2:1	279 [2474]	255 [2257]	231 [2041]	621 [5500]	258 [2284]	236 [2084]	213 [1885]	13,5 [119]	38,9 [344]
DTR142S-003	3:1	188 [1663]	171 [1518]	155 [1372]	478 [4230]	174 [1536]	158 [1401]	143 [1267]	11,6 [102]	44,1 [390]
DTR142S-004	4:1	135 [1194]	123 [1090]	111 [985]	414 [3660]	125 [1103]	114 [1006]	103 [910]	10,8 [95.1]	46,3 [410]
DTR142S-005P	5:1P	101 [896]	92 [818]	84 [739]	347 [3075]	93 [827]	85 [755]	77 [683]	10,6 [93.3]	47,4 [419]
DTR142S-006	6:1	329 [2909]	279 [2474]	271 [2402]	678 [6000]	322 [2846]	258 [2284]	251 [2218]	13,8 [122]	31,8 [281]
DTR142S-009	9:1	221 [1956]	188 [1663]	182 [1614]	532 [4710]	216 [1913]	174 [1536]	168 [1491]	11,6 [102]	39,6 [351]
DTR142S-010	10:1	339 [2996]	309 [2735]	279 [2474]	734 [6500]	334 [2958]	296 [2621]	258 [2284]	13,1 [116]	31,6 [280]
DTR142S-012	12:1	159 [1404]	135 [1194]	131 [1159]	454 [4020]	155 [1374]	125 [1103]	121 [1071]	11,1 [97.7]	43,4 [384]
DTR142S-015	15:1	228 [2014]	208 [1839]	188 [1663]	551 [4875]	225 [1989]	199 [1762]	174 [1536]	10,9 [95.9]	45,4 [402]
DTR142S-020	20:1	163 [1446]	149 [1320]	135 [1194]	768 [6800]	161 [1428]	143 [1265]	125 [1103]	10,4 [91.5]	43,3 [383]
DTR142S-025	25:1	123 [1085]	112 [991]	101 [896]	391 [3460]	121 [1071]	107 [949]	93 [827]	10,2 [89.8]	45,3 [401]
DTR142S-030	30:1	233 [2058]	223 [1970]	213 [1882]	573 [5070]	231 [2045]	218 [1932]	205 [1819]	10,6 [93.8]	38,8 [343]
DTR142S-040	40:1	167 [1478]	160 [1415]	153 [1352]	486 [4300]	166 [1469]	157 [1387]	148 [1306]	10,1 [89.4]	42,8 [379]
DTR142S-050	50:1	125 [1109]	120 [1061]	115 [1014]	404 [3575]	125 [1102]	118 [1041]	111 [980]	9,91 [87.6]	45,0 [398]
DTR142S-060	60:1	351 [3105]	346 [3061]	341 [3018]	814 [7200]	350 [3099]	344 [3042]	337 [2986]	13,8 [122]	31,0 [274]
DTR142S-075	75:1	236 [2084]	232 [2049]	228 [2014]	593 [5250]	235 [2079]	230 [2034]	225 [1989]	11,1 [97.9]	39,4 [348]
DTR142S-090	90:1	236 [2087]	233 [2058]	229 [2029]	597 [5280]	235 [2083]	231 [2045]	227 [2008]	11,6 [103]	39,1 [346]
DTR142S-100	100:1	352 [3114]	349 [3088]	346 [3061]	825 [7300]	351 [3110]	348 [3076]	344 [3042]	13,1 [116]	31,3 [278]
DTR142S-120	120:1	169 [1499]	167 [1478]	165 [1457]	506 [4480]	169 [1496]	166 [1469]	163 [1442]	11,1 [98.2]	43,0 [380]
DTR142S-125	125:1	127 [1123]	125 [1104]	123 [1085]	415 [3675]	127 [1120]	124 [1096]	121 [1071]	10,4 [91.7]	45,3 [401]
DTR142S-150	150:1	237 [2093]	235 [2076]	233 [2058]	607 [5370]	236 [2091]	234 [2068]	231 [2045]	10,9 [96.4]	39,3 [348]
DTR142S-200	200:1	353 [3120]	351 [3107]	350 [3094]	842 [7450]	352 [3118]	350 [3101]	349 [3085]	12,9 [114]	30,5 [270]
DTR142S-250	250:1	127 [1128]	126 [1118]	125 [1109]	421 [3725]	127 [1126]	126 [1114]	125 [1102]	10,2 [90.3]	45,2 [400]
DTR142S-300	300:1	237 [2098]	236 [2089]	235 [2080]	614 [5430]	237 [2096]	236 [2085]	234 [2074]	10,7 [94.3]	38,8 [343]
DTR142S-400	400:1	170 [1506]	169 [1500]	169 [1494]	518 [4580]	170 [1505]	169 [1497]	168 [1489]	10,2 [89.8]	42,8 [379]
DTR142S-500	500:1	128 [1130]	127 [1125]	127 [1121]	427 [3775]	128 [1129]	127 [1123]	126 [1117]	9,96 [88.1]	45,0 [398]

All ratios are available to ship in 24 hours through the Gearhead Express Program.

Ratio 5P is designed using only PowerTRUE face gearing technology.

<sup>1</sup> Ratios are exact, higher ratios and other custom options are also available, consult factory.

T<sub>r</sub> = Rated output torque at rated speed for specific hours of life.

J = Mass moment of inertia reflected to the input shaft (including pinion assembly)

T<sub>peak</sub> = Allowable momentary peak torque for emergency stop or heavy shock loading.

## Radial and Axial Load Ratings

### DTR060

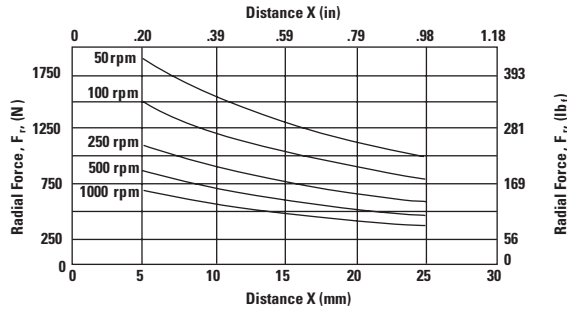
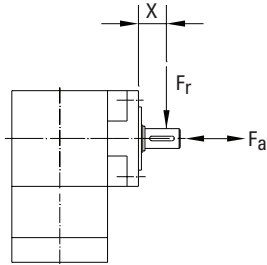

Speed rpm	Axial Load, $F_a$ N [lb.]
50	3075 [692]
100	2441 [549]
250	1798 [405]
500	1427 [321]
1000	1133 [255]

### DTR090

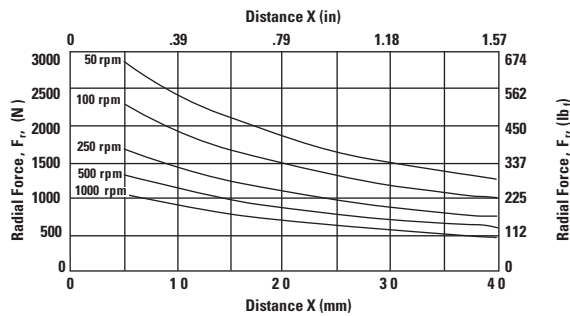
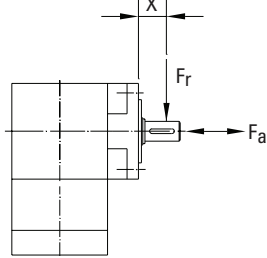

Speed rpm	Axial Load, $F_a$ N [lb.]
50	4506 [1014]
100	3576 [805]
250	2635 [593]
500	2091 [471]
1000	1660 [373]

### DTR115

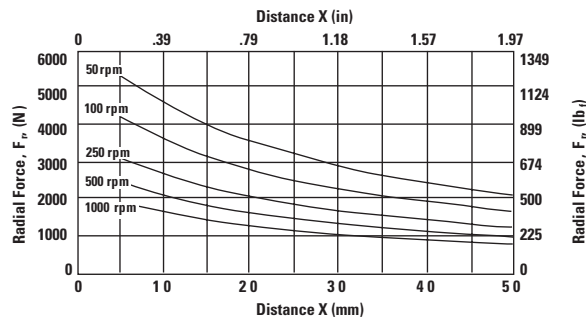
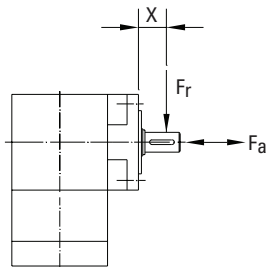

Speed rpm	Axial Load, $F_a$ N [lb.]
50	8196 [1844]
100	6505 [1464]
250	4793 [1078]
500	3804 [856]
1000	3019 [679]

### DTR142

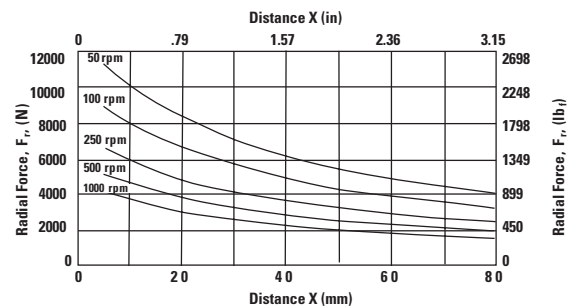
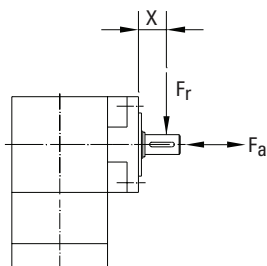

Speed rpm	Axial Load, $F_a$ N [lb.]
50	17023 [3830]
100	13511 [3040]
250	9956 [2240]
500	7902 [1778]
1000	6271 [1411]

These graphs display the allowable radial load at a given distance (X) from the mounting surface based on an  $L_{10}$  life of 10,000 hours for the mean output speed  $n_{mout}$ , as described on page 9.

# Micron TRUE Planetary® Gearheads

## Radial and Axial Load Ratings

### DTR060S

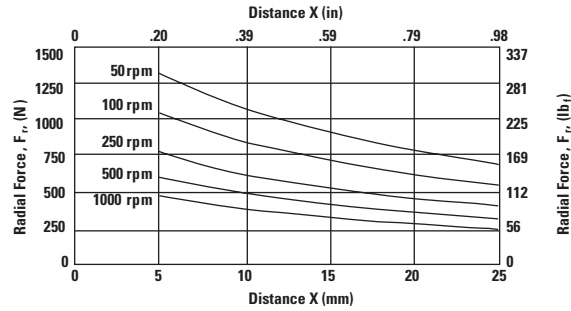
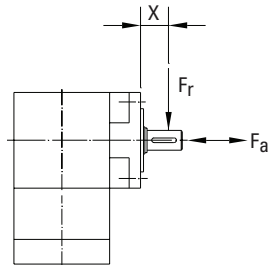

Speed rpm	Axial Load, $F_a$ N [lb.]
50	2155 [484]
100	1710 [384]
250	1260 [283]
500	1000 [225]
1000	794 [178]

### DTR090S

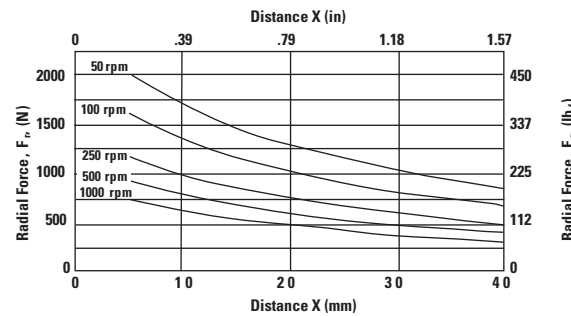
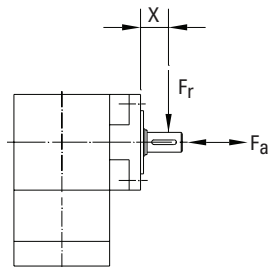

Speed rpm	Axial Load, $F_a$ N [lb.]
50	3157 [710]
100	2506 [563]
250	1846 [415]
500	1465 [329]
1000	1163 [261]

### DTR115S

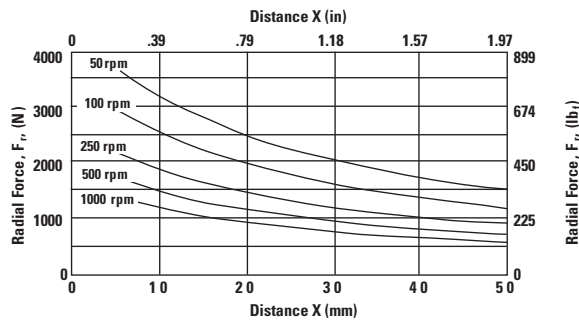
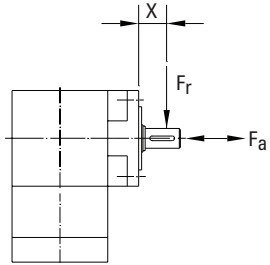

Speed rpm	Axial Load, $F_a$ N [lb.]
50	5742 [1291]
100	4558 [1025]
250	3358 [755]
500	2665 [599]
1000	2115 [476]

### DTR142S

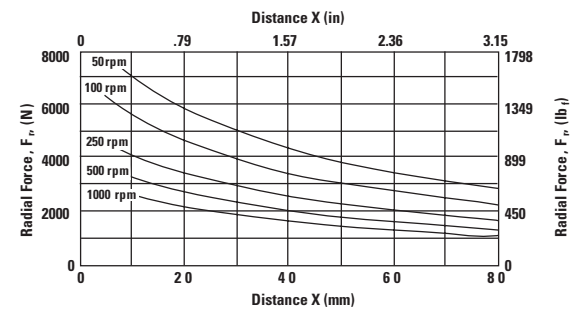
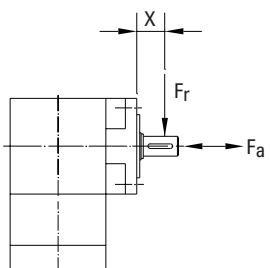

Speed rpm	Axial Load, $F_a$ N [lb.]
50	11925 [2681]
100	9465 [2128]
250	6974 [1568]
500	5535 [1244]
1000	4393 [988]

These graphs display the allowable radial load at a given distance (X) from the mounting surface based on an  $L_{10}$  life of 10,000 hours for the mean output speed  $n_{\text{mount}}$ , as described on page 9.



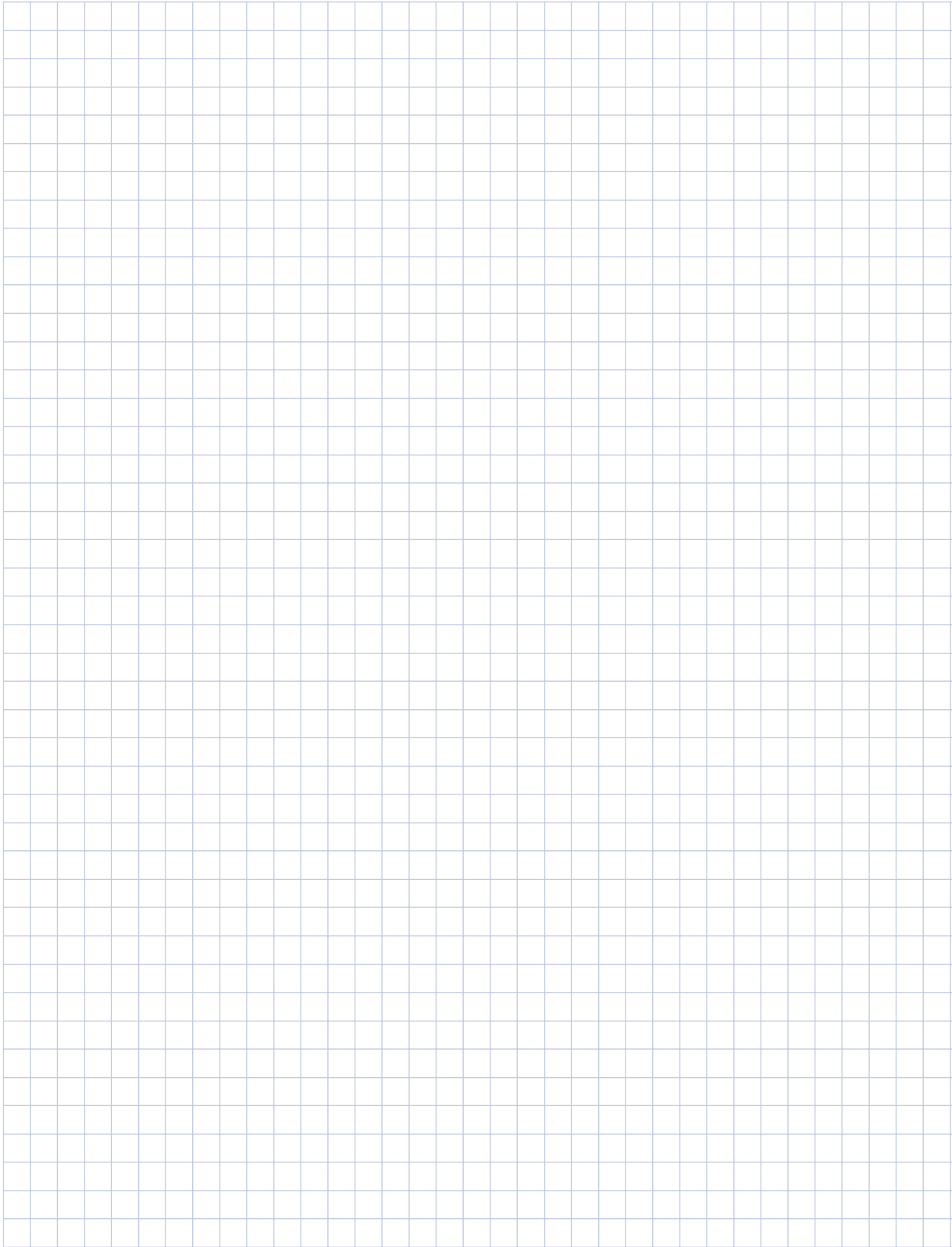

# Micron TRUE Planetary® Gearheads

## DuraTRUE™ 90 Hollow Shaft

### Right Angle Gearheads

Ready for Immediate Delivery	
Precision	8 arc-minutes
Frame Sizes	90 mm, 115 mm and 142 mm
Torque Capacity	up to 865 Nm
Ratio Availability	1:1 thru 500:1
Radial load capacity	up to 11150 N
Mounting System	RediMount™

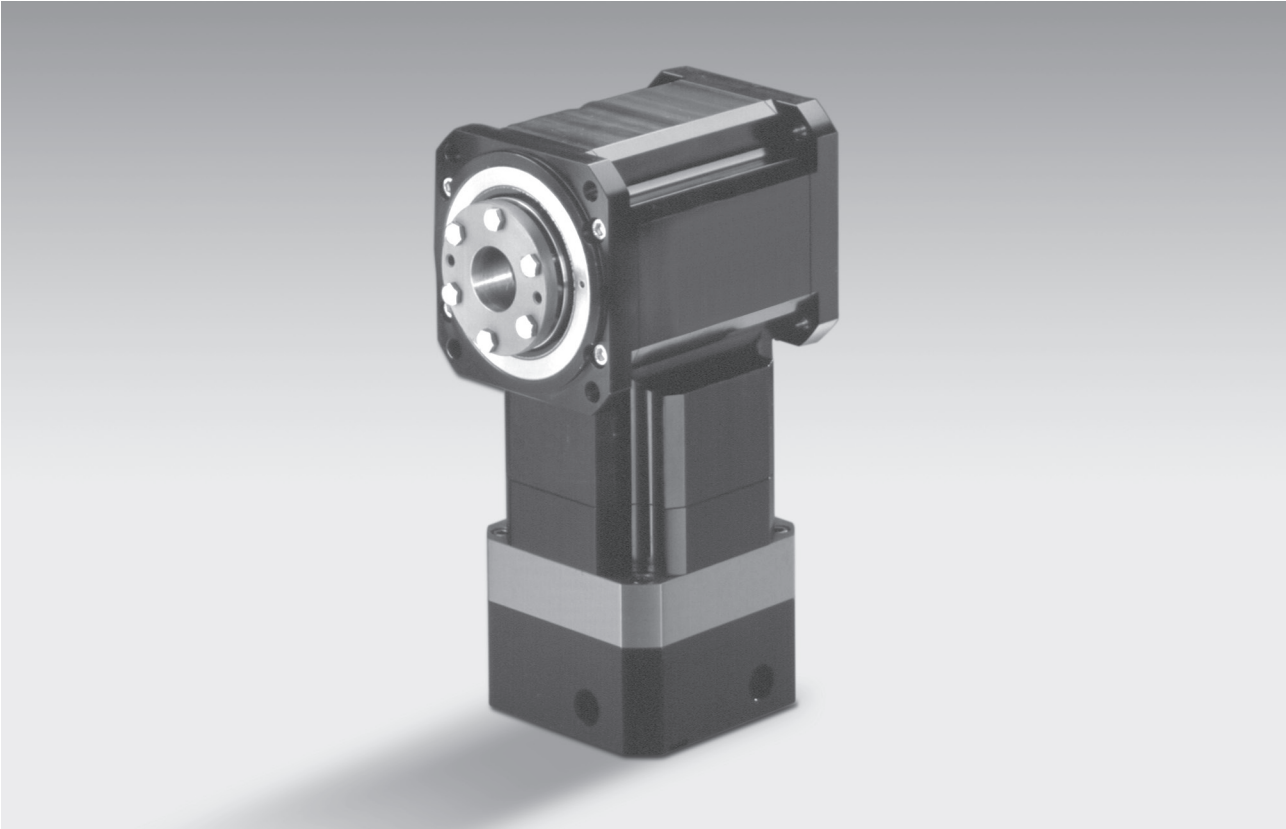

## DuraTRUE 90 Size 90H (Hollow Shaft)

### Right Angle Gearheads

### Metric

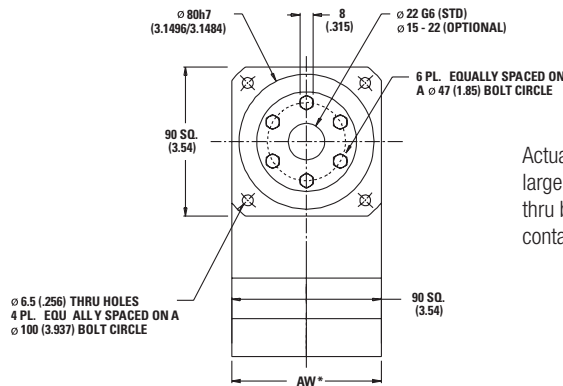
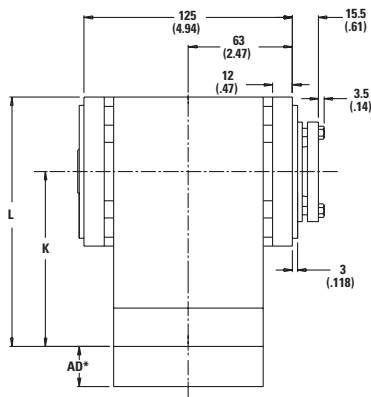

Actual thru bore of output shaft is larger than shown. For additional thru bore information, please contact application engineering.

Ratio <sup>1</sup>	Dimension 'K' mm [in.]	Dimension 'L' mm [in.]	Backlash [arc-min]	Weight kg [lb.]	Efficiency
1:1 to 5:1P	101 [3.99]	146 [5.76]	8 max	4.1 [9]	98%
5:1T to 50:1	124 [4.89]	169 [6.66]	9 max	4.8 [10]	93%
60:1 to 500:1	147 [5.79]	192 [7.56]	9 max	5.5 [12]	88%

All dimensions are: mm (in.)

AW\* = Adapter width

AD\* = Adapter length

Both will vary depending on motor.

Efficiency is calculated at 100% of the rated torque.

### Performance Specifications

Part Number	Ratio <sup>1</sup>	10,000 Hour Life				T peak Nm [in.-lb.]	20,000 Hour Life			J kg-cm <sup>2</sup> [in.-lb.-sec <sup>2</sup> ×10 <sup>-4</sup> ]	Torsional Stiffness Nm/arc-min [in.-lb./arc-min]
		T <sub>r</sub> (1000 rpm) Nm [in.-lb.]	T <sub>r</sub> (3000 rpm) Nm [in.-lb.]	T <sub>r</sub> (5000 rpm) Nm [in.-lb.]	T <sub>r</sub> (1000 rpm) Nm [in.-lb.]		T <sub>r</sub> (3000 rpm) Nm [in.-lb.]	T <sub>r</sub> (5000 rpm) Nm [in.-lb.]			
DTR090H-001	1:1	21 [188]	19 [171]	17 [155]	140 [1237]	20 [173]	18 [158]	16 [143]	3,11 [27.5]	4,3 [37.9]	
DTR090H-002	2:1	48 [426]	44 [389]	40 [352]	140 [1237]	44 [394]	41 [359]	37 [325]	1,59 [14.1]	6,5 [57.2]	
DTR090H-003	3:1	32 [281]	29 [256]	26 [232]	140 [1237]	29 [260]	27 [237]	24 [214]	1,37 [12.1]	7,3 [64.6]	
DTR090H-004	4:1	24 [215]	22 [196]	20 [177]	140 [1237]	22 [199]	20 [181]	19 [164]	1,27 [11.2]	7,6 [67.7]	
DTR090H-005P	5:1P	18 [158]	16 [144]	15 [131]	140 [1237]	17 [146]	15 [133]	14 [121]	1,25 [11.0]	7,8 [69.2]	
DTR090H-005T	5:1T	64 [568]	55 [483]	53 [469]	140 [1237]	63 [556]	50 [446]	49 [433]	1,64 [14.5]	5,1 [45.1]	
DTR090H-006	6:1	57 [501]	48 [426]	47 [414]	140 [1237]	55 [490]	44 [394]	43 [382]	1,63 [14.4]	5,1 [45.1]	
DTR090H-009	9:1	37 [331]	32 [281]	31 [273]	140 [1237]	37 [323]	29 [260]	28 [252]	1,37 [12.1]	6,4 [56.9]	
DTR090H-010	10:1	58 [516]	53 [471]	48 [426]	140 [1237]	58 [510]	51 [452]	44 [394]	1,54 [13.7]	5,0 [44.5]	
DTR090H-012	12:1	29 [253]	24 [215]	24 [209]	140 [1237]	28 [247]	22 [199]	22 [193]	1,31 [11.6]	7,1 [62.7]	
DTR090H-015	15:1	38 [340]	35 [311]	32 [281]	140 [1237]	38 [336]	34 [298]	29 [260]	1,28 [11.3]	7,4 [65.8]	
DTR090H-020	20:1	29 [261]	27 [238]	24 [215]	140 [1237]	29 [257]	26 [228]	22 [199]	1,22 [10.8]	7,1 [62.4]	
DTR090H-025	25:1	22 [192]	20 [175]	18 [158]	140 [1237]	21 [189]	19 [168]	17 [146]	1,20 [10.6]	7,4 [65.6]	
DTR090H-030	30:1	39 [348]	38 [333]	36 [318]	140 [1237]	39 [346]	37 [327]	35 [307]	1,25 [11.1]	6,1 [53.8]	
DTR090H-040	40:1	30 [266]	29 [255]	28 [243]	140 [1237]	30 [265]	28 [250]	27 [235]	1,19 [10.6]	6,8 [60.5]	
DTR090H-050	50:1	22 [196]	21 [188]	20 [179]	140 [1237]	22 [195]	21 [184]	20 [173]	1,17 [10.4]	7,3 [64.2]	
DTR090H-060	60:1	60 [535]	60 [527]	59 [520]	140 [1237]	60 [534]	59 [524]	58 [514]	1,63 [14.4]	4,9 [43.5]	
DTR090H-075	75:1	40 [352]	39 [346]	38 [340]	140 [1237]	40 [351]	39 [344]	38 [336]	1,31 [11.6]	6,4 [56.2]	
DTR090H-090	90:1	40 [353]	39 [348]	39 [343]	140 [1237]	40 [352]	39 [346]	38 [339]	1,37 [12.1]	6,3 [55.8]	
DTR090H-100	100:1	61 [536]	60 [532]	60 [527]	140 [1237]	61 [536]	60 [530]	59 [524]	1,55 [13.7]	5,0 [43.9]	
DTR090H-120	120:1	31 [270]	30 [266]	30 [262]	140 [1237]	30 [269]	30 [265]	29 [260]	1,31 [11.6]	7,0 [62.0]	
DTR090H-125	125:1	22 [198]	22 [195]	22 [192]	140 [1237]	22 [198]	22 [194]	21 [189]	1,23 [10.8]	7,4 [65.5]	
DTR090H-150	150:1	40 [354]	40 [351]	39 [348]	140 [1237]	40 [353]	39 [350]	39 [346]	1,29 [11.4]	6,3 [56.1]	
DTR090H-200	200:1	61 [538]	60 [535]	60 [533]	140 [1237]	61 [537]	60 [534]	60 [531]	1,52 [13.5]	4,6 [40.7]	
DTR090H-250	250:1	23 [199]	22 [198]	22 [196]	140 [1237]	22 [199]	22 [197]	22 [195]	1,21 [10.7]	7,4 [65.4]	
DTR090H-300	300:1	40 [355]	40 [353]	40 [352]	140 [1237]	40 [354]	40 [352]	40 [350]	1,26 [11.1]	6,1 [53.7]	
DTR090H-400	400:1	31 [271]	31 [270]	30 [269]	140 [1237]	31 [271]	30 [270]	30 [268]	1,20 [10.6]	6,8 [60.5]	
DTR090H-500	500:1	23 [200]	22 [199]	22 [198]	140 [1237]	23 [200]	22 [198]	22 [197]	1,18 [10.4]	7,3 [64.2]	

Ratio 5P is designed using only PowerTRUE face gearing technology.

Ratio 5T adds a True Planetary gearing stage for increased torque capacity.

<sup>1</sup> Ratios are exact, higher ratios are also available, consult factory.

T<sub>r</sub> = Rated output torque at rated speed for specific hours of life.

J = Mass moment of inertia reflected to the input shaft (including pinion assembly)

T<sub>peak</sub> = Allowable momentary peak torque for emergency stop or heavy shock loading.

# Micron TRUE Planetary® Gearheads

## DuraTRUE™ 90 Size 115H (Hollow Shaft)

### Right Angle Gearheads

Metric

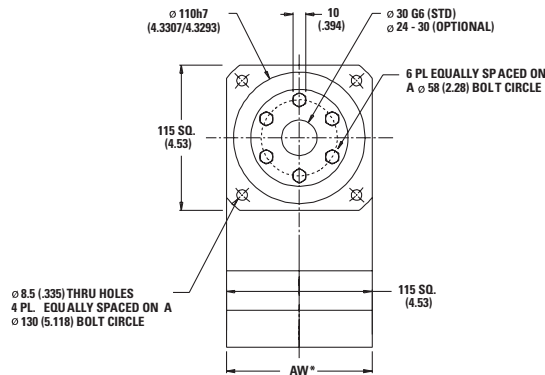
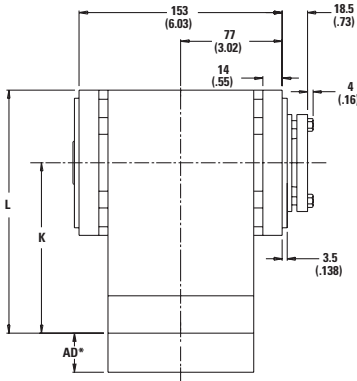

Actual thru bore of output shaft is larger than shown. For additional thru bore information, please contact application engineering.

Ratio <sup>1</sup>	Dimension 'K' mm [in.]	Dimension 'L' mm [in.]	Backlash [arc-min]	Weight kg [lb.]	Efficiency
1:1 to 5:1P	137 [5.41]	195 [7.67]	8 max	9 [20]	98%
5:1T to 50:1	169 [6.64]	226 [8.90]	9 max	11 [24]	93%
60:1 to 500:1	200 [7.87]	257 [10.13]	9 max	12 [27]	88%

All dimensions are: mm (in.)

AW\* = Adapter width

AD\* = Adapter length

Both will vary depending on motor.

Efficiency is calculated at 100% of the rated torque.

### Performance Specifications

Part Number	Ratio <sup>1</sup>	10,000 Hour Life			T peak Nm [in.-lb.]	20,000 Hour Life			J kg-cm <sup>2</sup> [in.-lb.-sec <sup>2</sup> x10 <sup>-4</sup> ]	Torsional Stiffness Nm/arc-min [in.-lb./arc-min]
		T <sub>r</sub> (1000 rpm) Nm [in.-lb.]	T <sub>r</sub> (3000 rpm) Nm [in.-lb.]	T <sub>r</sub> (5000 rpm) Nm [in.-lb.]		T <sub>r</sub> (1000 rpm) Nm [in.-lb.]	T <sub>r</sub> (3000 rpm) Nm [in.-lb.]	T <sub>r</sub> (5000 rpm) Nm [in.-lb.]		
DTR115H-001	1:1	63 [554]	57 [506]	52 [457]	283 [2505]	58 [512]	53 [467]	48 [422]	5,28 [46.7]	7,6 [67.6]
DTR115H-002	2:1	112 [989]	102 [903]	92 [816]	283 [2505]	103 [913]	94 [834]	85 [754]	2,71 [23.9]	12,5 [111]
DTR115H-003	3:1	87 [768]	79 [701]	72 [634]	283 [2505]	80 [709]	73 [647]	66 [585]	2,33 [20.6]	14,2 [126]
DTR115H-004	4:1	58 [511]	53 [467]	48 [422]	283 [2505]	53 [472]	49 [431]	44 [390]	2,16 [19.1]	14,9 [132]
DTR115H-005P	5:1P	43 [384]	40 [350]	36 [316]	283 [2505]	40 [354]	37 [323]	33 [292]	2,12 [18.8]	15,3 [135]
DTR115H-005T	5:1T	170 [1505]	126 [1117]	108 [958]	283 [2505]	143 [1262]	102 [907]	88 [778]	2,78 [24.6]	15,3 [135]
DTR115H-006	6:1	131 [1163]	112 [989]	109 [960]	283 [2505]	129 [1138]	103 [913]	100 [887]	2,77 [24.5]	10,2 [90.7]
DTR115H-009	9:1	102 [903]	87 [768]	84 [746]	283 [2505]	100 [884]	80 [709]	78 [689]	2,32 [20.5]	12,8 [113]
DTR115H-010	10:1	135 [1198]	124 [1094]	112 [989]	283 [2505]	134 [1183]	118 [1048]	103 [913]	2,63 [23.2]	10,2 [90.3]
DTR115H-012	12:1	68 [601]	58 [511]	56 [496]	283 [2505]	66 [588]	53 [472]	52 [458]	2,22 [19.6]	14,0 [124]
DTR115H-015	15:1	105 [930]	96 [849]	87 [768]	283 [2505]	104 [919]	92 [814]	80 [709]	2,18 [19.3]	14,6 [130]
DTR115H-020	20:1	70 [619]	64 [565]	58 [511]	283 [2505]	69 [612]	61 [542]	53 [472]	2,08 [18.4]	14,0 [124]
DTR115H-025	25:1	52 [465]	48 [424]	43 [384]	283 [2505]	52 [459]	46 [406]	40 [354]	2,04 [18.0]	14,6 [129]
DTR115H-030	30:1	107 [951]	103 [910]	98 [869]	283 [2505]	107 [945]	101 [892]	95 [840]	2,13 [18.9]	12,5 [111]
DTR115H-040	40:1	72 [633]	68 [606]	65 [579]	283 [2505]	71 [629]	67 [594]	63 [559]	2,03 [18.0]	13,8 [122]
DTR115H-050	50:1	54 [475]	51 [454]	49 [434]	283 [2505]	53 [472]	50 [446]	47 [419]	1,99 [17.6]	14,5 [128]
DTR115H-060	60:1	140 [1242]	138 [1224]	136 [1207]	283 [2505]	140 [1239]	137 [1217]	135 [1194]	2,78 [24.6]	10,0 [88.5]
DTR115H-075	75:1	109 [963]	107 [947]	105 [930]	283 [2505]	109 [960]	106 [939]	104 [919]	2,22 [19.7]	12,7 [112]
DTR115H-090	90:1	109 [964]	107 [951]	106 [937]	283 [2505]	109 [962]	107 [945]	105 [927]	2,33 [20.6]	12,6 [112]
DTR115H-100	100:1	141 [1245]	140 [1235]	138 [1224]	283 [2505]	141 [1244]	137 [1230]	137 [1217]	2,64 [23.3]	10,1 [89.5]
DTR115H-120	120:1	73 [642]	72 [633]	70 [624]	283 [2505]	72 [641]	70 [629]	70 [617]	2,23 [19.7]	13,9 [123]
DTR115H-125	125:1	54 [481]	53 [473]	52 [465]	283 [2505]	54 [480]	52 [469]	52 [459]	2,08 [18.4]	14,6 [129]
DTR115H-150	150:1	109 [967]	108 [959]	107 [951]	283 [2505]	109 [966]	107 [955]	107 [945]	2,19 [19.4]	12,7 [112]
DTR115H-200	200:1	141 [1248]	140 [1243]	140 [1237]	283 [2505]	141 [1247]	139 [1240]	138 [1234]	2,59 [22.9]	9,8 [87.1]
DTR115H-250	250:1	55 [483]	54 [479]	54 [475]	283 [2505]	54 [482]	53 [477]	53 [472]	2,05 [18.1]	14,6 [129]
DTR115H-300	300:1	109 [969]	109 [965]	109 [961]	283 [2505]	109 [968]	108 [963]	108 [958]	2,14 [18.9]	12,5 [111]
DTR115H-400	400:1	73 [645]	73 [642]	72 [640]	283 [2505]	73 [645]	73 [645]	72 [638]	2,04 [18.1]	13,8 [122]
DTR115H-500	500:1	55 [484]	54 [482]	54 [480]	283 [2505]	55 [483]	54 [481]	54 [478]	2,00 [17.7]	14,5 [128]

Ratio 5P is designed using only PowerTRUE face gearing technology.

Ratio 5T adds a True Planetary gearing stage for increased torque capacity.

<sup>1</sup> Ratios are exact, higher ratios are also available, consult factory.

T<sub>r</sub> = Rated output torque at rated speed for specific hours of life.

J = Mass moment of inertia reflected to the input shaft (including pinion assembly)

T<sub>peak</sub> = Allowable momentary peak torque for emergency stop or heavy shock loading.

# Micron TRUE Planetary® Gearheads

## DuraTRUE 90 Size 142H (Hollow Shaft)

### Right Angle Gearheads

### Metric

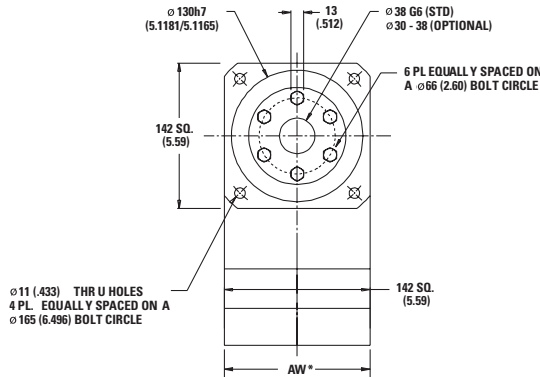
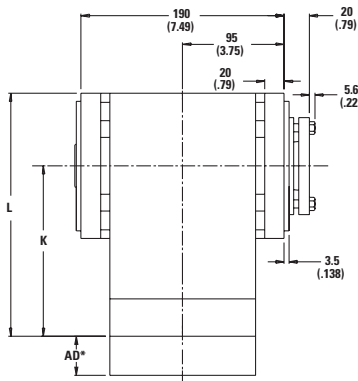

Actual thru bore of output shaft is larger than shown. For additional thru bore information, please contact application engineering.

Ratio <sup>1</sup>	Dimension 'K' mm [in.]	Dimension 'L' mm [in.]	Backlash [arc-min]	Weight kg [lb.]	Efficiency
1:1 to 5:1P	160 [6.29]	231 [9.09]	8 max	19 [43]	98%
6:1 to 50:1	209 [8.23]	280 [11.03]	9 max	24 [53]	93%
60:1 to 500:1	259 [10.18]	329 [12.95]	9 max	28 [62]	88%

All dimensions are: mm (in.)  
 AW\* = Adapter width  
 AD\* = Adapter length  
 Both will vary depending on motor.  
 Efficiency is calculated at 100% of the rated torque.

### Performance Specifications

Part Number	Ratio <sup>1</sup>	10,000 Hour Life				T peak Nm [in.-lb.]	20,000 Hour Life			J kg-cm <sup>2</sup> [in.-lb.-sec <sup>2</sup> x10 <sup>-4</sup> ]	Torsional Stiffness Nm/arc-min [in.-lb./arc-min]
		T <sub>r</sub> (1000 rpm) Nm [in.-lb.]	T <sub>r</sub> (3000 rpm) Nm [in.-lb.]	T <sub>r</sub> (5000 rpm) Nm [in.-lb.]	T <sub>r</sub> (1000 rpm) Nm [in.-lb.]		T <sub>r</sub> (3000 rpm) Nm [in.-lb.]	T <sub>r</sub> (5000 rpm) Nm [in.-lb.]			
DTR142H-001	1:1	135 [1194]	123 [1090]	111 [985]	865 [7659]	125 [1103]	114 [1006]	103 [910]	26.3 [232]	23.7 [210]	
DTR142H-002	2:1	279 [2474]	255 [2257]	231 [2041]	865 [7659]	258 [2284]	236 [2084]	213 [1885]	13.5 [119]	38.9 [344]	
DTR142H-003	3:1	188 [1663]	171 [1518]	155 [1372]	865 [7659]	174 [1536]	158 [1401]	143 [1267]	11.6 [102]	44.1 [390]	
DTR142H-004	4:1	135 [1194]	123 [1090]	111 [985]	865 [7659]	125 [1103]	114 [1006]	103 [910]	10.8 [95.1]	46.3 [410]	
DTR142H-005P	5:1P	101 [896]	92 [818]	84 [739]	865 [7659]	93 [827]	85 [755]	77 [683]	10.6 [93.3]	47.4 [419]	
DTR142H-006	6:1	329 [2909]	279 [2474]	271 [2402]	865 [7659]	322 [2846]	258 [2284]	251 [2218]	13.8 [122]	31.8 [281]	
DTR142H-009	9:1	221 [1956]	188 [1663]	182 [1614]	865 [7659]	216 [1913]	174 [1536]	168 [1491]	11.6 [102]	39.6 [351]	
DTR142H-010	10:1	339 [2996]	309 [2735]	279 [2474]	865 [7659]	334 [2958]	296 [2621]	258 [2284]	13.1 [116]	31.6 [280]	
DTR142H-012	12:1	159 [1404]	135 [1194]	131 [1159]	865 [7659]	155 [1374]	125 [1103]	121 [1071]	11.1 [97.7]	43.4 [384]	
DTR142H-015	15:1	228 [2014]	208 [1839]	188 [1663]	865 [7659]	225 [1989]	199 [1762]	174 [1536]	10.9 [95.9]	45.4 [402]	
DTR142H-020	20:1	163 [1446]	149 [1320]	135 [1194]	865 [7659]	161 [1428]	143 [1265]	125 [1103]	10.4 [91.5]	43.3 [383]	
DTR142H-025	25:1	123 [1085]	112 [991]	101 [896]	865 [7659]	121 [1071]	107 [949]	93 [827]	10.2 [89.8]	45.3 [401]	
DTR142H-030	30:1	233 [2058]	223 [1970]	213 [1882]	865 [7659]	231 [2045]	218 [1932]	205 [1819]	10.6 [93.8]	38.8 [343]	
DTR142H-040	40:1	167 [1478]	160 [1415]	153 [1352]	865 [7659]	166 [1469]	157 [1387]	148 [1306]	10.1 [89.4]	42.8 [379]	
DTR142H-050	50:1	125 [1109]	120 [1061]	115 [1014]	865 [7659]	125 [1102]	118 [1041]	111 [980]	9.91 [87.6]	45.0 [398]	
DTR142H-060	60:1	351 [3105]	346 [3061]	341 [3018]	865 [7659]	350 [3099]	344 [3042]	337 [2986]	13.8 [122]	31.0 [274]	
DTR142H-075	75:1	236 [2084]	232 [2049]	228 [2014]	865 [7659]	235 [2079]	230 [2034]	225 [1989]	11.1 [97.9]	39.4 [348]	
DTR142H-090	90:1	236 [2087]	233 [2058]	229 [2029]	865 [7659]	235 [2083]	231 [2045]	227 [2008]	11.6 [103]	39.1 [346]	
DTR142H-100	100:1	352 [3114]	349 [3088]	346 [3061]	865 [7659]	351 [3110]	348 [3076]	344 [3042]	13.1 [116]	31.3 [278]	
DTR142H-120	120:1	169 [1499]	167 [1478]	165 [1457]	865 [7659]	169 [1496]	166 [1469]	163 [1442]	11.1 [98.2]	43.0 [380]	
DTR142H-125	125:1	127 [1123]	125 [1104]	123 [1085]	865 [7659]	127 [1120]	124 [1096]	121 [1071]	10.4 [91.7]	45.3 [401]	
DTR142H-150	150:1	237 [2093]	235 [2076]	233 [2058]	865 [7659]	236 [2091]	234 [2068]	231 [2045]	10.9 [96.4]	39.3 [348]	
DTR142H-200	200:1	353 [3120]	351 [3107]	350 [3094]	865 [7659]	352 [3118]	350 [3101]	349 [3085]	12.9 [114]	30.5 [270]	
DTR142H-250	250:1	127 [1128]	126 [1118]	125 [1109]	865 [7659]	127 [1126]	126 [1114]	125 [1102]	10.2 [90.3]	45.2 [400]	
DTR142H-300	300:1	237 [2098]	236 [2089]	235 [2080]	865 [7659]	237 [2096]	236 [2085]	234 [2074]	10.7 [94.3]	38.8 [343]	
DTR142H-400	400:1	170 [1506]	169 [1500]	169 [1494]	865 [7659]	170 [1505]	169 [1497]	168 [1489]	10.2 [89.8]	42.8 [379]	
DTR142H-500	500:1	128 [1130]	127 [1125]	127 [1121]	865 [7659]	128 [1129]	127 [1123]	126 [1117]	9.96 [88.1]	45.0 [398]	

Ratio 5P is designed using only PowerTRUE face gearing technology.  
<sup>1</sup> Ratios are exact, higher ratios are also available, consult factory.  
 Tr = Rated output torque at rated speed for specific hours of life.

J = Mass moment of inertia reflected to the input shaft (including pinion assembly)  
 Tpeak = Allowable momentary peak torque for emergency stop or heavy shock loading.

# Micron TRUE Planetary® Gearheads

## Radial and Axial Load Ratings

### DTR090H

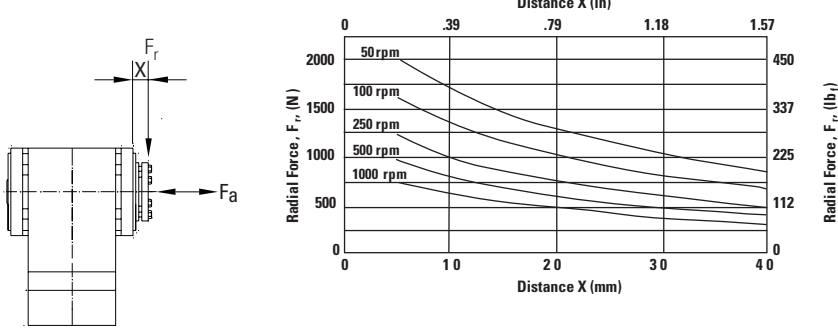

Speed rpm	Axial Load, $F_a$ N [lbf]
50	3157 [710]
100	2506 [563]
250	1846 [415]
500	1465 [329]
1000	1163 [261]

### DTR115H

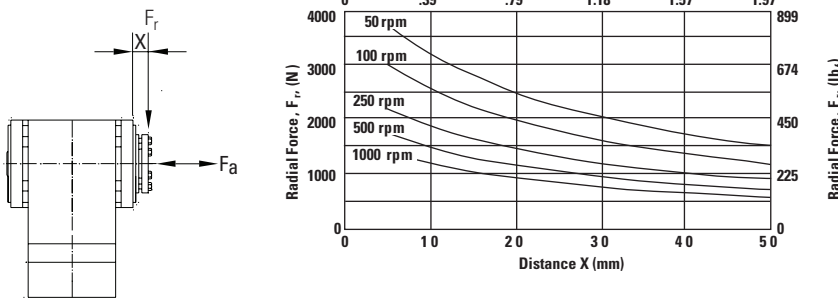

Speed rpm	Axial Load, $F_a$ N [lbf]
50	5742 [1291]
100	4558 [1025]
250	3358 [755]
500	2665 [599]
1000	2115 [476]

### DTR142H

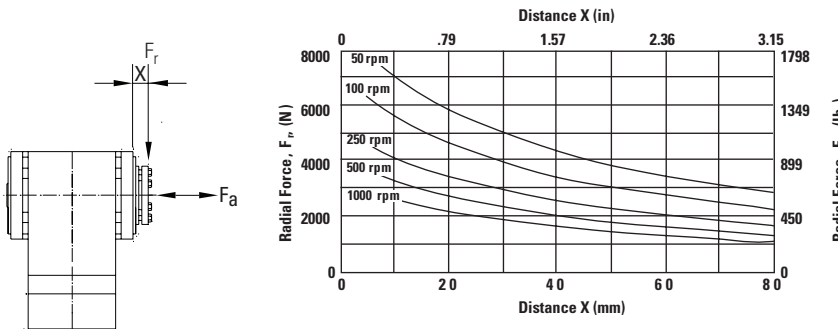

Speed rpm	Axial Load, $F_a$ N [lbf]
50	11925 [2681]
100	9465 [2128]
250	6974 [1568]
500	5535 [1244]
1000	4393 [988]

These graphs display the allowable radial load at a given distance (X) from the mounting surface based on an  $L_{10}$  life of 10,000 hours for the mean output speed  $n_{mout}$ , as described on page 9.

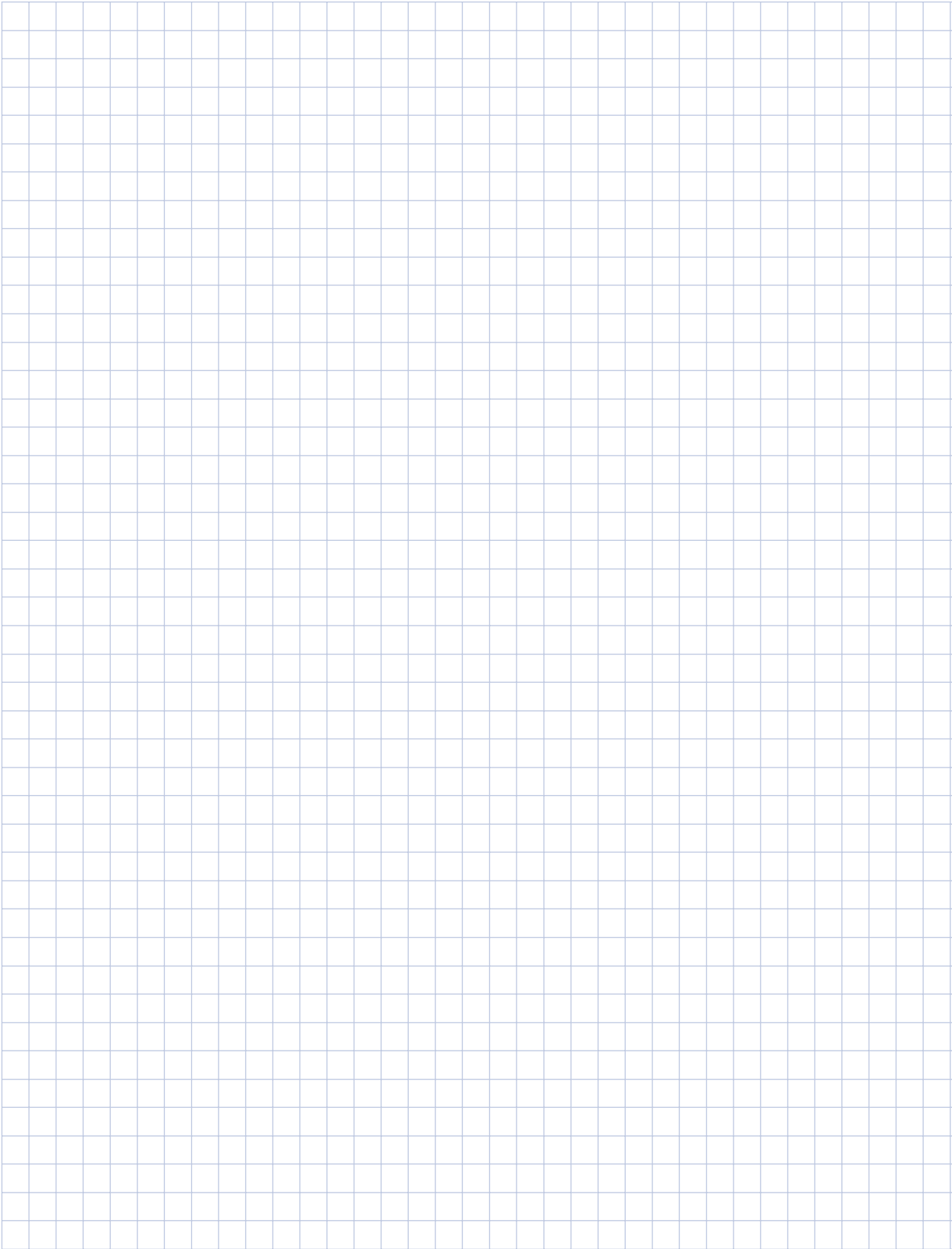

# Micron TRUE Planetary® Gearheads

## DuraTRUE™ 90 Dual Shaft

### Right Angle Gearheads

Ready for Immediate Delivery	
Precision	8 arc-minutes
Frame Sizes	60 mm, 90 mm, 115 mm and 142 mm
Torque Capacity	up to 865 Nm
Ratio Availability	1:1 thru 500:1
Radial load capacity	up to 11150 N
Mounting System	RediMount™

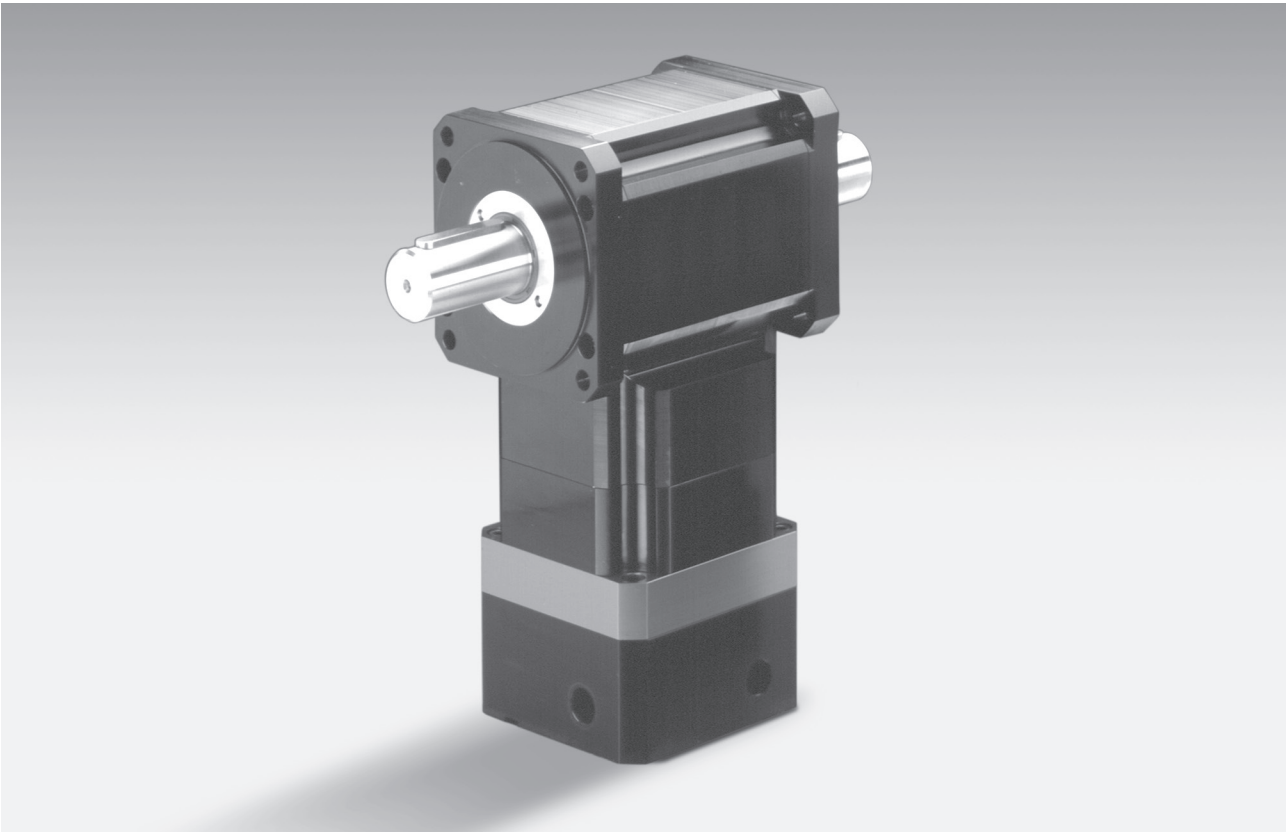



## DuraTRUE 90 Size 60D (Dual Shaft)

### Right Angle Gearheads

### Metric

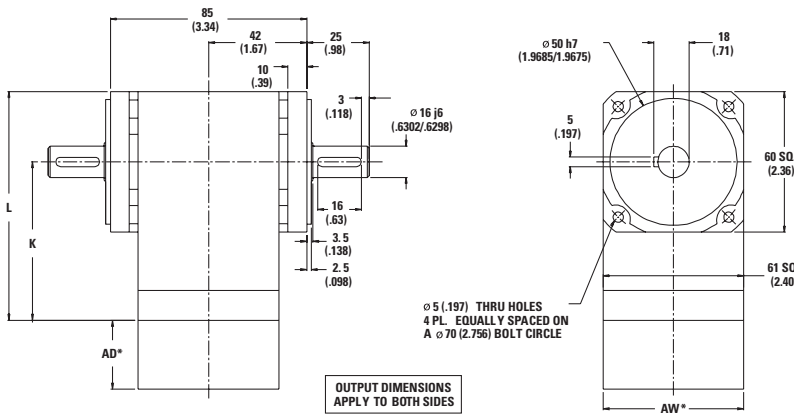

Ratio <sup>1</sup>	Dimension 'K' mm [in.]	Dimension 'L' mm [in.]	Backlash [arc-min]	Weight kg [lb.]	Efficiency
1:1 to 5:1P	80 [3.15]	110 [4.33]	8 max	2,3 [5]	98%
5:1T to 50:1	97 [3.83]	127 [5.01]	9 max	2,5 [5.5]	93%
60:1 to 500:1	115 [4.52]	145 [5.70]	9 max	2,7 [6]	88%

All dimensions are: mm (in.)

AW\* = Adapter width

AD\* = Adapter length

Both will vary depending on motor.

Efficiency is calculated at 100% of the rated torque.

## Performance Specifications

Part Number	Ratio <sup>1</sup>	10,000 Hour Life				T peak Nm [in.-lb.]	20,000 Hour Life			J kg-cm <sup>2</sup> [in.-lb.-sec <sup>2</sup> ×10 <sup>-4</sup> ]	Torsional Stiffness Nm/arc-min [in.-lb./arc-min]
		T <sub>r</sub> (1000 rpm) Nm [in.-lb.]	T <sub>r</sub> (3000 rpm) Nm [in.-lb.]	T <sub>r</sub> (5000 rpm) Nm [in.-lb.]	T <sub>r</sub> (1000 rpm) Nm [in.-lb.]		T <sub>r</sub> (3000 rpm) Nm [in.-lb.]	T <sub>r</sub> (5000 rpm) Nm [in.-lb.]			
DTR060D-001	1:1	7 [66]	7 [60]	6 [54]	46 [407]	7 [61]	6 [56]	6 [50]	,79 [7.0]	1,8 [15.8]	
DTR060D-002	2:1	16 [145]	15 [132]	14 [120]	46 [407]	15 [134]	14 [122]	12 [111]	,41 [3.6]	2,7 [23.8]	
DTR060D-003	3:1	10 [92]	10 [84]	9 [76]	46 [407]	10 [85]	9 [78]	8 [70]	,35 [3.1]	3,0 [26.9]	
DTR060D-004	4:1	8 [68]	7 [62]	6 [56]	46 [407]	7 [63]	6 [57]	6 [52]	,32 [2.9]	3,2 [28.2]	
DTR060D-005P	5:1P	6 [56]	6 [51]	5 [46]	46 [407]	6 [52]	5 [47]	5 [43]	,32 [2.8]	3,3 [28.8]	
DTR060D-005T	5:1T	23 [200]	18 [162]	16 [138]	46 [407]	21 [182]	15 [132]	13 [112]	,42 [3.7]	3,3 [28.8]	
DTR060D-006	6:1	19 [171]	16 [145]	16 [141]	46 [407]	19 [167]	15 [134]	15 [130]	,41 [3.7]	2,1 [18.8]	
DTR060D-009	9:1	12 [109]	10 [92]	10 [90]	46 [407]	12 [106]	10 [85]	9 [83]	,35 [3.1]	2,7 [23.7]	
DTR060D-010	10:1	20 [176]	18 [160]	16 [145]	46 [407]	20 [174]	17 [154]	15 [134]	,39 [3.5]	2,1 [18.5]	
DTR060D-012	12:1	9 [80]	8 [68]	7 [66]	46 [407]	9 [78]	7 [63]	7 [61]	,33 [3.0]	3,0 [26.1]	
DTR060D-015	15:1	13 [112]	12 [102]	10 [92]	46 [407]	12 [110]	11 [98]	10 [85]	,33 [2.9]	3,1 [27.4]	
DTR060D-020	20:1	9 [82]	8 [75]	8 [68]	46 [407]	9 [81]	8 [72]	7 [63]	,31 [2.8]	2,9 [26.0]	
DTR060D-025	25:1	8 [68]	7 [62]	6 [56]	46 [407]	8 [67]	7 [59]	6 [52]	,31 [2.7]	3,1 [27.3]	
DTR060D-030	30:1	13 [114]	12 [109]	12 [105]	46 [407]	13 [114]	12 [107]	11 [101]	,32 [2.8]	2,5 [22.4]	
DTR060D-040	40:1	10 [84]	9 [81]	9 [77]	46 [407]	9 [84]	9 [79]	8 [74]	,30 [2.7]	2,8 [25.2]	
DTR060D-050	50:1	8 [69]	7 [66]	7 [63]	46 [407]	8 [69]	7 [65]	7 [61]	,30 [2.6]	3,0 [26.8]	
DTR060D-060	60:1	21 [182]	20 [180]	20 [177]	46 [407]	21 [182]	20 [178]	20 [175]	,42 [3.7]	2,0 [18.1]	
DTR060D-075	75:1	13 [116]	13 [114]	13 [112]	46 [407]	13 [115]	13 [113]	12 [110]	,33 [3.0]	2,6 [23.4]	
DTR060D-090	90:1	13 [116]	13 [114]	13 [113]	46 [407]	13 [116]	13 [114]	13 [111]	,35 [3.1]	2,6 [23.3]	
DTR060D-100	100:1	21 [183]	20 [181]	20 [180]	46 [407]	21 [182]	20 [180]	20 [178]	,40 [3.5]	2,1 [18.3]	
DTR060D-120	120:1	10 [85]	10 [84]	9 [83]	46 [407]	10 [85]	9 [84]	9 [82]	,33 [3.0]	2,9 [25.8]	
DTR060D-125	125:1	8 [70]	8 [69]	8 [68]	46 [407]	8 [70]	8 [68]	8 [67]	,31 [2.8]	3,1 [27.3]	
DTR060D-150	150:1	13 [116]	13 [115]	13 [114]	46 [407]	13 [116]	13 [115]	13 [114]	,33 [2.9]	2,6 [23.4]	
DTR060D-200	200:1	21 [183]	21 [182]	21 [181]	46 [407]	21 [183]	21 [182]	20 [181]	,39 [3.4]	1,9 [17.0]	
DTR060D-250	250:1	8 [70]	8 [70]	8 [69]	46 [407]	8 [70]	8 [69]	8 [69]	,31 [2.7]	3,1 [27.3]	
DTR060D-300	300:1	13 [116]	13 [116]	13 [115]	46 [407]	13 [116]	13 [116]	13 [115]	,32 [2.8]	2,5 [22.4]	
DTR060D-400	400:1	10 [86]	10 [85]	10 [85]	46 [407]	10 [86]	10 [85]	10 [85]	,31 [2.7]	2,8 [25.2]	
DTR060D-500	500:1	8 [70]	8 [70]	8 [70]	46 [407]	8 [70]	8 [70]	8 [70]	,30 [2.7]	3,0 [26.8]	

Ratio 5P is designed using only PowerTRUE face gearing technology.

Ratio 5T adds a True Planetary gearing stage for increased torque capacity.

<sup>1</sup> Ratios are exact, higher ratios are also available, consult factory.

T<sub>r</sub> = Rated output torque at rated speed for specific hours of life.

J = Mass moment of inertia reflected to the input shaft (including pinion assembly)

T<sub>peak</sub> = Allowable momentary peak torque for emergency stop or heavy shock loading.

# Micron TRUE Planetary® Gearheads

## DuraTRUE™ 90 Size 90D (Dual Shaft)

### Right Angle Gearheads

Metric

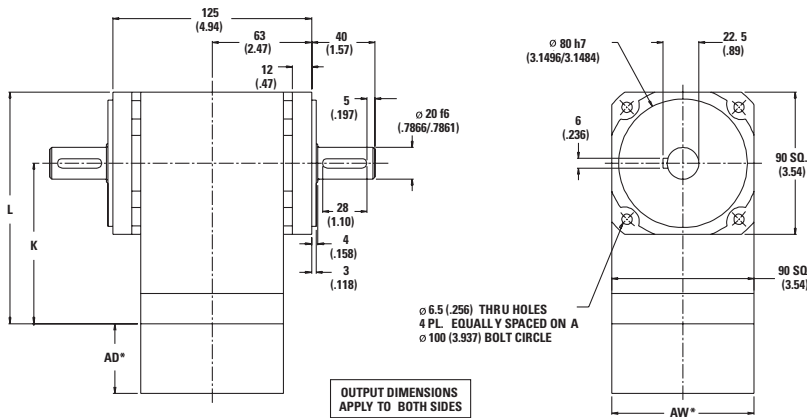

Ratio <sup>1</sup>	Dimension 'K' mm [in.]	Dimension 'L' mm [in.]	Backlash [arc-min]	Weight kg [lb.]	Efficiency
1:1 to 5:1P	101 [3.99]	146 [5.76]	8 max	4,1 [9]	98%
5:1T to 50:1	124 [4.89]	169 [6.66]	9 max	4,8 [10]	93%
60:1 to 500:1	147 [5.79]	192 [7.56]	9 max	5,5 [12]	88%

All dimensions are: mm (in.)

AW\* = Adapter width

AD\* = Adapter length

Both will vary depending on motor.

Efficiency is calculated at 100% of the rated torque.

## Performance Specifications

Part Number	Ratio <sup>1</sup>	10,000 Hour Life				T peak Nm [in.-lb.]	20,000 Hour Life			J kg-cm <sup>2</sup> [in.-lb.-sec <sup>2</sup> x10 <sup>-4</sup> ]	Torsional Stiffness Nm/arc-min [in.-lb./arc-min]
		T <sub>r</sub> (1000 rpm) Nm [in.-lb.]	T <sub>r</sub> (3000 rpm) Nm [in.-lb.]	T <sub>r</sub> (5000 rpm) Nm [in.-lb.]	T <sub>r</sub> (1000 rpm) Nm [in.-lb.]		T <sub>r</sub> (3000 rpm) Nm [in.-lb.]	T <sub>r</sub> (5000 rpm) Nm [in.-lb.]			
DTR090D-001	1:1	21 [188]	19 [171]	17 [155]	140 [1237]	20 [173]	18 [158]	16 [143]	3,11 [27.5]	4,3 [37.9]	
DTR090D-002	2:1	48 [426]	44 [389]	40 [352]	140 [1237]	44 [394]	41 [359]	37 [325]	1,59 [14.1]	6,5 [57.2]	
DTR090D-003	3:1	32 [281]	29 [256]	26 [232]	140 [1237]	29 [260]	27 [237]	24 [214]	1,37 [12.1]	7,3 [64.6]	
DTR090D-004	4:1	24 [215]	22 [196]	20 [177]	140 [1237]	22 [199]	20 [181]	19 [164]	1,27 [11.2]	7,6 [67.7]	
DTR090D-005P	5:1P	18 [158]	16 [144]	15 [131]	140 [1237]	17 [146]	15 [133]	14 [121]	1,25 [11.0]	7,8 [69.2]	
DTR090D-005T	5:1T	64 [568]	55 [483]	53 [469]	140 [1237]	63 [556]	50 [446]	49 [433]	1,64 [14.5]	5,1 [45.1]	
DTR090D-006	6:1	57 [501]	48 [426]	47 [414]	140 [1237]	55 [490]	44 [394]	43 [382]	1,63 [14.4]	5,1 [45.1]	
DTR090D-009	9:1	37 [331]	32 [281]	31 [273]	140 [1237]	37 [323]	29 [260]	28 [252]	1,37 [12.1]	6,4 [56.9]	
DTR090D-010	10:1	58 [516]	53 [471]	48 [426]	140 [1237]	58 [510]	51 [452]	44 [394]	1,54 [13.7]	5,0 [44.5]	
DTR090D-012	12:1	29 [253]	24 [215]	24 [209]	140 [1237]	28 [247]	22 [199]	22 [193]	1,31 [11.6]	7,1 [62.7]	
DTR090D-015	15:1	38 [340]	35 [311]	32 [281]	140 [1237]	38 [336]	34 [298]	29 [260]	1,28 [11.3]	7,4 [65.8]	
DTR090D-020	20:1	29 [261]	27 [238]	24 [215]	140 [1237]	29 [257]	26 [228]	22 [199]	1,22 [10.8]	7,1 [62.4]	
DTR090D-025	25:1	22 [192]	20 [175]	18 [158]	140 [1237]	21 [189]	19 [168]	17 [146]	1,20 [10.6]	7,4 [65.6]	
DTR090D-030	30:1	39 [348]	38 [333]	36 [318]	140 [1237]	39 [346]	37 [327]	35 [307]	1,25 [11.1]	6,1 [53.8]	
DTR090D-040	40:1	30 [266]	29 [255]	28 [243]	140 [1237]	30 [265]	28 [250]	27 [235]	1,19 [10.6]	6,8 [60.5]	
DTR090D-050	50:1	22 [196]	21 [188]	20 [179]	140 [1237]	22 [195]	21 [184]	20 [173]	1,17 [10.4]	7,3 [64.2]	
DTR090D-060	60:1	60 [535]	60 [527]	59 [520]	140 [1237]	60 [534]	59 [524]	58 [514]	1,63 [14.4]	4,9 [43.5]	
DTR090D-075	75:1	40 [352]	39 [346]	38 [340]	140 [1237]	40 [351]	39 [344]	38 [336]	1,31 [11.6]	6,4 [56.2]	
DTR090D-090	90:1	40 [353]	39 [348]	39 [343]	140 [1237]	40 [352]	39 [346]	38 [339]	1,37 [12.1]	6,3 [55.8]	
DTR090D-100	100:1	61 [536]	60 [532]	60 [527]	140 [1237]	61 [536]	60 [530]	59 [524]	1,55 [13.7]	5,0 [43.9]	
DTR090D-120	120:1	31 [270]	30 [266]	30 [262]	140 [1237]	30 [269]	30 [265]	29 [260]	1,31 [11.6]	7,0 [62.0]	
DTR090D-125	125:1	22 [198]	22 [195]	22 [192]	140 [1237]	22 [198]	22 [194]	21 [189]	1,23 [10.8]	7,4 [65.5]	
DTR090D-150	150:1	40 [354]	40 [351]	39 [348]	140 [1237]	40 [353]	39 [350]	39 [346]	1,29 [11.4]	6,3 [56.1]	
DTR090D-200	200:1	61 [538]	60 [535]	60 [533]	140 [1237]	61 [537]	60 [534]	60 [531]	1,52 [13.5]	4,6 [40.7]	
DTR090D-250	250:1	23 [199]	22 [198]	22 [196]	140 [1237]	22 [199]	22 [197]	22 [195]	1,21 [10.7]	7,4 [65.4]	
DTR090D-300	300:1	40 [355]	40 [353]	40 [352]	140 [1237]	40 [354]	40 [352]	40 [350]	1,26 [11.1]	6,1 [53.7]	
DTR090D-400	400:1	31 [271]	31 [270]	30 [269]	140 [1237]	31 [271]	30 [270]	30 [268]	1,20 [10.6]	6,8 [60.5]	
DTR090D-500	500:1	23 [200]	22 [199]	22 [198]	140 [1237]	23 [200]	22 [198]	22 [197]	1,18 [10.4]	7,3 [64.2]	

Ratio 5P is designed using only PowerTRUE face gearing technology.

Ratio 5T adds a True Planetary gearing stage for increased torque capacity.

<sup>1</sup> Ratios are exact, higher ratios are also available, consult factory.

T<sub>r</sub> = Rated output torque at rated speed for specific hours of life.

J = Mass moment of inertia reflected to the input shaft (including pinion assembly)

T<sub>peak</sub> = Allowable momentary peak torque for emergency stop or heavy shock loading.

## DuraTRUE 90 Size 115D (Dual Shaft)

### Right Angle Gearheads

### Metric

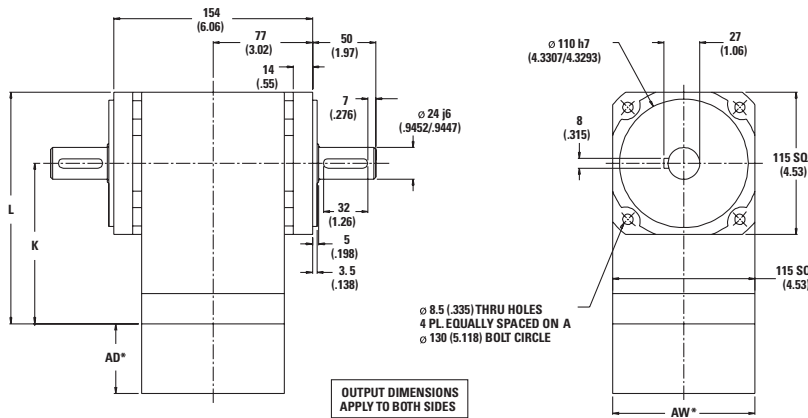

Ratio <sup>1</sup>	Dimension 'K' mm [in.]	Dimension 'L' mm [in.]	Backlash [arc-min]	Weight kg [lb.]	Efficiency
1:1 to 5:1P	137 (5.41)	195 (7.76)	8 max	9 [20]	98%
5:1T to 50:1	169 (6.64)	226 (8.90)	9 max	11 [24]	93%
60:1 to 500:1	200 (7.87)	257 (10.13)	9 max	12 [27]	88%

All dimensions are: mm (in.)  
 AW\* = Adapter width  
 AD\* = Adapter length  
 Both will vary depending on motor.  
 Efficiency is calculated at 100% of the rated torque.

### Performance Specifications

Part Number	Ratio <sup>1</sup>	10,000 Hour Life			T peak Nm [in.-lb.]	20,000 Hour Life			J kg-cm <sup>2</sup> [in.-lb.-sec <sup>2</sup> x10 <sup>-4</sup> ]	Torsional Stiffness Nm/arc-min [in.-lb./arc-min]
		T <sub>r</sub> (1000 rpm) Nm [in.-lb.]	T <sub>r</sub> (3000 rpm) Nm [in.-lb.]	T <sub>r</sub> (5000 rpm) Nm [in.-lb.]		T <sub>r</sub> (1000 rpm) Nm [in.-lb.]	T <sub>r</sub> (3000 rpm) Nm [in.-lb.]	T <sub>r</sub> (5000 rpm) Nm [in.-lb.]		
DTR115D-001	1:1	63 [554]	57 [506]	52 [457]	283 [2505]	58 [512]	53 [467]	48 [422]	5,28 [46.7]	7,6 [67.6]
DTR115D-002	2:1	112 [989]	102 [903]	92 [816]	283 [2505]	103 [913]	94 [834]	85 [754]	2,71 [23.9]	12,5 [111]
DTR115D-003	3:1	87 [768]	79 [701]	72 [634]	283 [2505]	80 [709]	73 [647]	66 [585]	2,33 [20.6]	14,2 [126]
DTR115D-004	4:1	58 [511]	53 [467]	48 [422]	283 [2505]	53 [472]	49 [431]	44 [390]	2,16 [19.1]	14,9 [132]
DTR115D-005P	5:1P	43 [384]	40 [350]	36 [316]	283 [2505]	40 [354]	37 [323]	33 [292]	2,12 [18.8]	15,3 [135]
DTR115D-005T	5:1T	170 [1505]	126 [1117]	108 [958]	283 [2505]	143 [1262]	102 [907]	88 [778]	2,78 [24.6]	15,3 [135]
DTR115D-006	6:1	131 [1163]	112 [989]	109 [960]	283 [2505]	129 [1138]	103 [913]	100 [887]	2,77 [24.5]	10,2 [90.7]
DTR115D-009	9:1	102 [903]	87 [768]	84 [746]	283 [2505]	100 [884]	80 [709]	78 [689]	2,32 [20.5]	12,8 [113]
DTR115D-010	10:1	135 [1198]	124 [1094]	112 [989]	283 [2505]	134 [1183]	118 [1048]	103 [913]	2,63 [23.2]	10,2 [90.3]
DTR115D-012	12:1	68 [601]	58 [511]	56 [496]	283 [2505]	66 [588]	53 [472]	52 [458]	2,22 [19.6]	14,0 [124]
DTR115D-015	15:1	105 [930]	96 [849]	87 [768]	283 [2505]	104 [919]	92 [814]	80 [709]	2,18 [19.3]	14,6 [130]
DTR115D-020	20:1	70 [619]	64 [565]	58 [511]	283 [2505]	69 [612]	61 [542]	53 [472]	2,08 [18.4]	14,0 [124]
DTR115D-025	25:1	52 [465]	48 [424]	43 [384]	283 [2505]	52 [459]	46 [406]	40 [354]	2,04 [18.0]	14,6 [129]
DTR115D-030	30:1	107 [951]	103 [910]	98 [869]	283 [2505]	107 [945]	101 [892]	95 [840]	2,13 [18.9]	12,5 [111]
DTR115D-040	40:1	72 [633]	68 [606]	65 [579]	283 [2505]	71 [629]	67 [594]	63 [559]	2,03 [18.0]	13,8 [122]
DTR115D-050	50:1	54 [475]	51 [454]	49 [434]	283 [2505]	53 [472]	50 [446]	47 [419]	1,99 [17.6]	14,5 [128]
DTR115D-060	60:1	140 [1242]	138 [1224]	136 [1207]	283 [2505]	140 [1239]	137 [1217]	135 [1194]	2,78 [24.6]	10,0 [88.5]
DTR115D-075	75:1	109 [963]	107 [947]	105 [930]	283 [2505]	109 [960]	106 [939]	104 [919]	2,22 [19.7]	12,7 [112]
DTR115D-090	90:1	109 [964]	107 [951]	106 [937]	283 [2505]	109 [962]	107 [945]	105 [927]	2,33 [20.6]	12,6 [112]
DTR115D-100	100:1	141 [1245]	140 [1235]	138 [1224]	283 [2505]	141 [1244]	139 [1230]	137 [1217]	2,64 [23.3]	10,1 [89.5]
DTR115D-120	120:1	73 [642]	72 [633]	70 [624]	283 [2505]	72 [641]	71 [629]	70 [617]	2,23 [19.7]	13,9 [123]
DTR115D-125	125:1	54 [481]	53 [473]	52 [465]	283 [2505]	54 [480]	53 [469]	52 [459]	2,08 [18.4]	14,6 [129]
DTR115D-150	150:1	109 [967]	108 [959]	107 [951]	283 [2505]	109 [966]	108 [955]	107 [945]	2,19 [19.4]	12,7 [112]
DTR115D-200	200:1	141 [1248]	140 [1243]	140 [1237]	283 [2505]	141 [1247]	140 [1240]	139 [1234]	2,59 [22.9]	9,8 [87.1]
DTR115D-250	250:1	55 [483]	54 [479]	54 [475]	283 [2505]	54 [482]	54 [477]	53 [472]	2,05 [18.1]	14,6 [129]
DTR115D-300	300:1	109 [969]	109 [965]	109 [961]	283 [2505]	109 [968]	109 [963]	108 [958]	2,14 [18.9]	12,5 [111]
DTR115D-400	400:1	73 [645]	73 [642]	73 [640]	283 [2505]	73 [645]	72 [641]	72 [638]	2,04 [18.1]	13,8 [122]
DTR115D-500	500:1	55 [484]	54 [482]	54 [480]	283 [2505]	55 [483]	54 [481]	54 [478]	2,00 [17.7]	14,5 [128]

Ratio 5P is designed using only PowerTRUE face gearing technology.  
 Ratio 5T adds a True Planetary gearing stage for increased torque capacity.  
<sup>1</sup> Ratios are exact, higher ratios are also available, consult factory.

T<sub>r</sub> = Rated output torque at rated speed for specific hours of life.  
 J = Mass moment of inertia reflected to the input shaft (including pinion assembly)  
 Tpeak = Allowable momentary peak torque for emergency stop or heavy shock loading.

# Micron TRUE Planetary® Gearheads

## DuraTRUE™ 90 Size 142D (Dual Shaft)

### Right Angle Gearheads

Metric

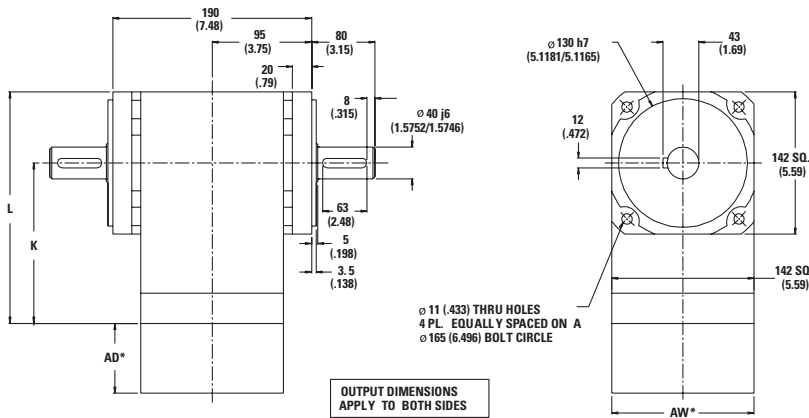

Ratio <sup>1</sup>	Dimension 'K' mm [in.]	Dimension 'L' mm [in.]	Backlash [arc-min]	Weight kg [lb.]	Efficiency
1:1 to 5:1P	160 [6.29]	231 [9.09]	8 max	19 [43]	98%
6:1 to 50:1	209 [8.23]	280 [11.03]	9 max	24 [53]	93%
60:1 to 500:1	259 [10.18]	329 [12.95]	9 max	28 [62]	88%

All dimensions are: mm (in.)

AW\* = Adapter width

AD\* = Adapter length

Both will vary depending on motor.

Efficiency is calculated at 100% of the rated torque.

### Performance Specifications

Part Number	Ratio <sup>1</sup>	10,000 Hour Life				T peak Nm [in.-lb.]	20,000 Hour Life			J kg-cm <sup>2</sup> [in.-lb.-sec <sup>2</sup> ×10 <sup>-4</sup> ]	Torsional Stiffness Nm/arc-min [in.-lb./arc-min]
		T <sub>r</sub> (1000 rpm) Nm [in.-lb.]	T <sub>r</sub> (3000 rpm) Nm [in.-lb.]	T <sub>r</sub> (5000 rpm) Nm [in.-lb.]	T <sub>r</sub> (1000 rpm) Nm [in.-lb.]		T <sub>r</sub> (3000 rpm) Nm [in.-lb.]	T <sub>r</sub> (5000 rpm) Nm [in.-lb.]			
DTR142D-001	1:1	135 [1194]	123 [1090]	111 [985]	865 [7659]	125 [1103]	114 [1006]	103 [910]	26,3 [232]	23,7 [210]	
DTR142D-002	2:1	279 [2474]	255 [2257]	231 [2041]	865 [7659]	258 [2284]	236 [2084]	213 [1885]	13,5 [119]	38,9 [344]	
DTR142D-003	3:1	188 [1663]	171 [1518]	155 [1372]	865 [7659]	174 [1536]	158 [1401]	143 [1267]	11,6 [102]	44,1 [390]	
DTR142D-004	4:1	135 [1194]	123 [1090]	111 [985]	865 [7659]	125 [1103]	114 [1006]	103 [910]	10,8 [95.1]	46,3 [410]	
DTR142D-005P	5:1P	101 [896]	92 [818]	84 [739]	865 [7659]	93 [827]	85 [755]	77 [683]	10,6 [93.3]	47,4 [419]	
DTR142D-006	6:1	329 [2909]	279 [2474]	271 [2402]	865 [7659]	322 [2846]	258 [2284]	251 [2218]	13,8 [122]	31,8 [281]	
DTR142D-009	9:1	221 [1956]	188 [1663]	182 [1614]	865 [7659]	216 [1913]	174 [1536]	168 [1491]	11,6 [102]	39,6 [351]	
DTR142D-010	10:1	339 [2996]	309 [2735]	279 [2474]	865 [7659]	334 [2958]	296 [2621]	258 [2284]	13,1 [116]	31,6 [280]	
DTR142D-012	12:1	159 [1404]	135 [1194]	131 [1159]	865 [7659]	155 [1374]	125 [1103]	121 [1071]	11,1 [97.7]	43,4 [384]	
DTR142D-015	15:1	228 [2014]	208 [1839]	188 [1663]	865 [7659]	225 [1989]	199 [1762]	174 [1536]	10,9 [95.9]	45,4 [402]	
DTR142D-020	20:1	163 [1446]	149 [1320]	135 [1194]	865 [7659]	161 [1428]	143 [1265]	125 [1103]	10,4 [91.5]	43,3 [383]	
DTR142D-025	25:1	123 [1085]	112 [991]	101 [896]	865 [7659]	121 [1071]	107 [949]	93 [827]	10,2 [89.8]	45,3 [401]	
DTR142D-030	30:1	233 [2058]	223 [1970]	213 [1882]	865 [7659]	231 [2045]	218 [1932]	205 [1819]	10,6 [93.8]	38,8 [343]	
DTR142D-040	40:1	167 [1478]	160 [1415]	153 [1352]	865 [7659]	166 [1469]	157 [1387]	148 [1306]	10,1 [89.4]	42,8 [379]	
DTR142D-050	50:1	125 [1109]	120 [1061]	115 [1014]	865 [7659]	125 [1102]	118 [1041]	111 [980]	9,91 [87.6]	45,0 [398]	
DTR142D-060	60:1	351 [3105]	346 [3061]	341 [3018]	865 [7659]	350 [3099]	344 [3042]	337 [2986]	13,8 [122]	31,0 [274]	
DTR142D-075	75:1	236 [2084]	232 [2049]	228 [2014]	865 [7659]	235 [2079]	230 [2034]	225 [1989]	11,1 [97.9]	39,4 [348]	
DTR142D-090	90:1	236 [2087]	233 [2058]	229 [2029]	865 [7659]	235 [2083]	231 [2045]	227 [2008]	11,6 [103]	39,1 [346]	
DTR142D-100	100:1	352 [3114]	349 [3088]	346 [3061]	865 [7659]	351 [3110]	348 [3076]	344 [3042]	13,1 [116]	31,3 [278]	
DTR142D-120	120:1	169 [1499]	167 [1478]	165 [1457]	865 [7659]	169 [1496]	166 [1469]	163 [1442]	11,1 [98.2]	43,0 [380]	
DTR142D-125	125:1	127 [1123]	125 [1104]	123 [1085]	865 [7659]	127 [1120]	124 [1096]	121 [1071]	10,4 [91.7]	45,3 [401]	
DTR142D-150	150:1	237 [2093]	235 [2076]	233 [2058]	865 [7659]	236 [2091]	234 [2068]	231 [2045]	10,9 [96.4]	39,3 [348]	
DTR142D-200	200:1	353 [3120]	351 [3107]	350 [3094]	865 [7659]	352 [3118]	350 [3101]	349 [3085]	12,9 [114]	30,5 [270]	
DTR142D-250	250:1	127 [1128]	126 [1118]	125 [1109]	865 [7659]	127 [1126]	126 [1114]	125 [1102]	10,2 [90.3]	45,2 [400]	
DTR142D-300	300:1	237 [2098]	236 [2089]	235 [2080]	865 [7659]	237 [2096]	236 [2085]	234 [2074]	10,7 [94.3]	38,8 [343]	
DTR142D-400	400:1	170 [1506]	169 [1500]	169 [1494]	865 [7659]	170 [1505]	169 [1497]	168 [1489]	10,2 [89.8]	42,8 [379]	
DTR142D-500	500:1	128 [1130]	127 [1125]	127 [1121]	865 [7659]	128 [1129]	127 [1123]	126 [1117]	9,96 [88.1]	45,0 [398]	

Ratio 5P is designed using only PowerTRUE face gearing technology.

<sup>1</sup> Ratios are exact, higher ratios are also available, consult factory.

T<sub>r</sub> = Rated output torque at rated speed for specific hours of life.

J = Mass moment of inertia reflected to the input shaft (including pinion assembly)

T<sub>peak</sub> = Allowable momentary peak torque for emergency stop or heavy shock loading.

## Radial and Axial Load Ratings

### DTR060D

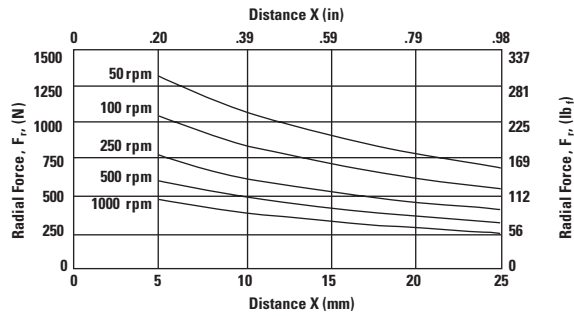
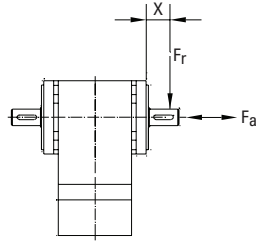

Speed rpm	Axial Load, $F_a$ N [lb <sub>f</sub> ]
50	2155 [484]
100	1710 [384]
250	1260 [283]
500	1000 [225]
1000	794 [178]

### DTR090D

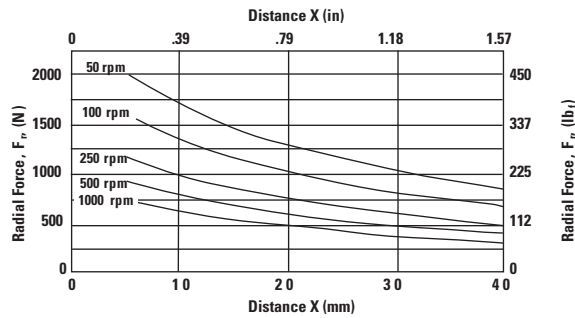
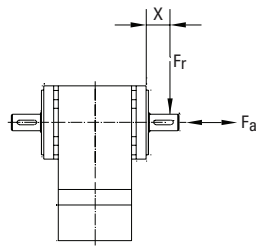

Speed rpm	Axial Load, $F_a$ N [lb <sub>f</sub> ]
50	3157 [710]
100	2506 [563]
250	1846 [415]
500	1465 [329]
1000	1163 [261]

### DTR115D

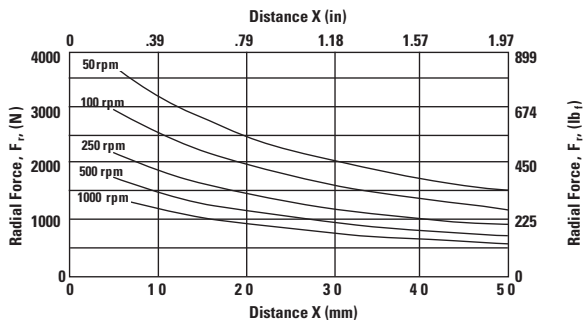
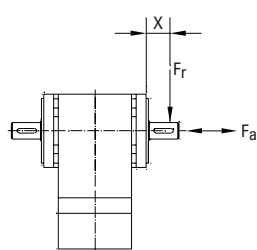

Speed rpm	Axial Load, $F_a$ N [lb <sub>f</sub> ]
50	5742 [1291]
100	4558 [1025]
250	3358 [755]
500	2665 [599]
1000	2115 [476]

### DTR142D

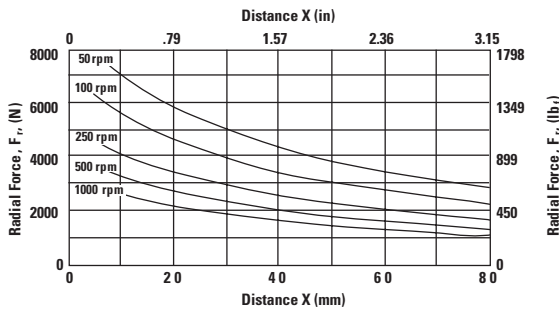
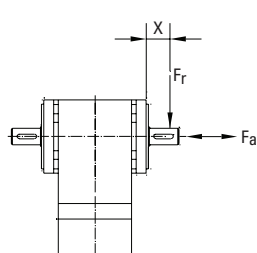

Speed rpm	Axial Load, $F_a$ N [lb <sub>f</sub> ]
50	11925 [2681]
100	9465 [2128]
250	6974 [1568]
500	5535 [1244]
1000	4393 [988]

These graphs display the allowable radial load at a given distance (X) from the mounting surface based on an L<sub>10</sub> life of 10,000 hours for the mean output speed  $n_{\text{mount}}$ , as described on page 9.

# Micron TRUE Planetary® Gearheads

## ValueTRUE™

### True Planetary Gearheads

Ready for Immediate Delivery	
<b>Precision</b>	4 arc-minutes
<b>Frame Sizes</b>	60 mm, 75 mm, 90 mm, 100 mm, 115 mm, 140 mm, 180 mm and 220 mm
<b>Torque Capacity</b>	up to 2970 Nm
<b>Ratio Availability</b>	4:1 thru 100:1
<b>Mounting System</b>	RediMount™

Both in-line and right angles available

- ValueTRUE is a new high-performance, price-competitive line of Micron True Planetary Gearheads
- Low cost— 30% less than typical market pricing
- Helical Crowned True Planetary gearing improved load capacity, lower backlash and smoother and quieter operation compared to non-helical gearheads
- Ultra Precision – 4 arc-mins of backlash
- Drop-in, low-cost replacement for most common helical gearheads
- Stainless steel output housing provides rock-solid durability, suitable for environmentally sensitive applications



**Micron True Planetary® Gearheads  
shipped within 24 hours!**

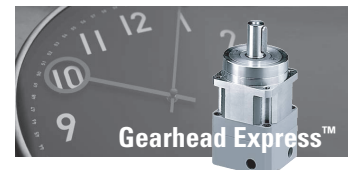

**Need it fast? Go to the back cover  
of the catalog for details.**

### Helical True Planetary Gearheads

Part Number	Stages	Backlash (arc-min)	Efficiency	Weight kg [lbs.]	Ratio Availability
VT006	1	4	95%	2 [4.4]	4:1, 5:1, 7:1, 10:1
	2	5	90%	2.5 [5.5]	16:1, 20:1, 25:1, 28:1, 35:1, 40:1, 50:1, 70:1, 100:1
VT075	1	4	95%	2.5 [5.5]	4:1, 5:1, 7:1, 10:1
	2	5	90%	3.0 [6.6]	16:1, 20:1, 25:1, 28:1, 35:1, 40:1, 50:1, 70:1, 100:1
VT090	1	4	95%	2.5 [5.5]	4:1, 5:1, 7:1, 10:1
	2	5	90%	3.0 [6.6]	16:1, 20:1, 25:1, 28:1, 35:1, 40:1, 50:1, 70:1, 100:1
VT010	1	4	95%	6 [13]	4:1, 5:1, 7:1, 10:1
	2	5	90%	8 [18]	16:1, 20:1, 25:1, 28:1, 35:1, 40:1, 50:1, 70:1, 100:1
VT115	1	4	95%	6 [13]	4:1, 5:1, 7:1, 10:1
	2	5	90%	8 [18]	16:1, 20:1, 25:1, 28:1, 35:1, 40:1, 50:1, 70:1, 100:1
VT014	1	4	95%	14 [31]	4:1, 5:1, 7:1, 10:1
	2	5	90%	18 [40]	16:1, 20:1, 25:1, 28:1, 35:1, 40:1, 50:1, 70:1, 100:1
VT018	1	4	95%	40 [88]	4:1, 5:1, 7:1, 10:1
	2	5	90%	45 [99]	16:1, 20:1, 25:1, 28:1, 35:1, 40:1, 50:1, 70:1, 100:1
VT022	1	4	95%	74 [162]	4:1, 5:1, 7:1, 10:1
	2	5	90%	95 [209]	16:1, 20:1, 25:1, 28:1, 35:1, 40:1, 50:1, 70:1, 100:1
VTR006	1	5	93%	3 [6.6]	8:1, 10:1, 12:1, 14:1, 15:1, 16:1, 20:1, 25:1, 28:1, 30:1, 35:1, 40:1, 50:1
VTR075	1	5	93%	5.3 [11.1]	8:1, 10:1, 12:1, 14:1, 15:1, 16:1, 20:1, 25:1, 28:1, 30:1, 35:1, 40:1, 50:1
VTR090	1	5	93%	5.3 [11.1]	8:1, 10:1, 12:1, 14:1, 15:1, 16:1, 20:1, 25:1, 28:1, 30:1, 35:1, 40:1, 50:1
VTR010	1	5	93%	12 [26.2]	4:1, 5:1, 8:1, 10:1, 12:1, 14:1, 15:1, 16:1, 20:1, 25:1, 28:1, 30:1, 35:1, 40:1, 50:1
VTR115	1	5	93%	12 [26.2]	4:1, 5:1, 8:1, 10:1, 12:1, 14:1, 15:1, 16:1, 20:1, 25:1, 28:1, 30:1, 35:1, 40:1, 50:1
VTR014	1	5	93%	29 [64]	4:1, 5:1, 8:1, 10:1, 12:1, 14:1, 15:1, 16:1, 20:1, 25:1, 28:1, 30:1, 35:1, 40:1, 50:1
VTR018	1	5	93%	48 [106]	4:1, 5:1, 8:1, 10:1, 12:1, 14:1, 15:1, 16:1, 20:1, 25:1, 28:1, 30:1, 35:1, 40:1, 50:1

All ratios in frame size 60, 75, 100 and 140 are available to ship in 24 hours through the Gearhead Express Program.

- \* Efficiency measured at 100% rated torque
- \* Backlash is maximum for the life of the gearhead
- \* For other ratios, please contact factory

# Micron TRUE Planetary® Gearheads

## ValueTRUE™

### Helical True Planetary Gearheads

VT006  
VT075  
VT010  
VT014  
VT018  
VT022

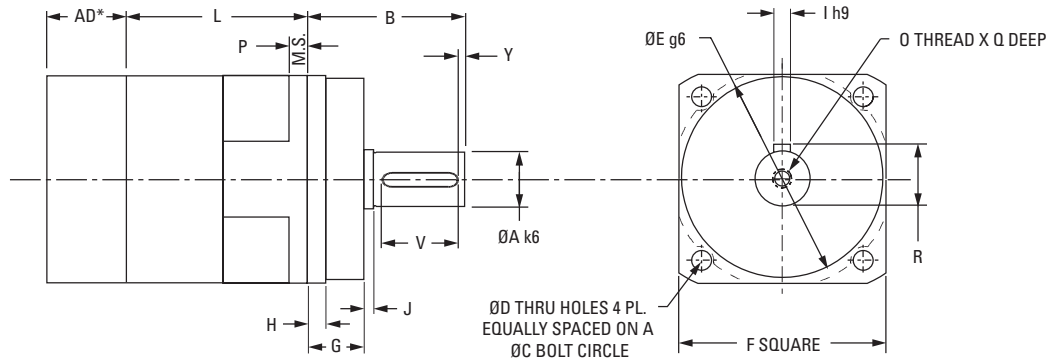

VT090  
VT115

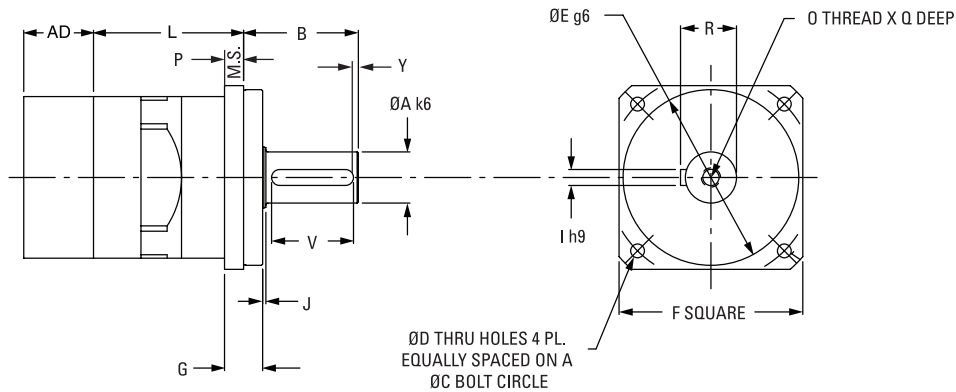

### Inline Dimensions

Part Number	F Flange Square mm [in.]	A Output Shaft Diameter mm [in.]	B Output Shaft Length mm [in.]	Y Shaft End Distance mm [in.]	V Keyway Length mm [in.]	R Keyway Height mm [in.]	I Key Square mm [in.]	J Shoulder Length mm [in.]	E Pilot Diameter mm [in.]
VT006	61 [2.40]	16 [0.63]	48 [1.89]	1 [0.04]	25 [0.98]	18 [0.71]	5 [0.20]	1 [0.04]	60 [2.36]
VT075	75 [2.95]	22 [0.86]	56 [2.20]	1,5 [0.06]	32 [1.26]	24,5 [0.97]	6 [0.24]	1 [0.04]	70 [2.75]
VT090	90 [3.54]	22 [0.86]	48 [1.89]	1,5 [0.06]	32 [1.26]	24,5 [0.97]	6 [0.24]	1 [0.04]	80 [1.48]
VT010	101 [3.98]	32 [1.26]	88 [3.46]	3 [0.12]	50 [1.97]	35 [1.38]	10 [0.39]	2 [0.08]	90 [3.54]
VT115	115 [4.53]	32 [1.26]	72 [2.83]	3 [0.12]	50 [1.97]	35 [1.38]	10 [0.39]	2 [0.08]	110 [4.33]
VT014	141 [5.55]	40 [1.57]	112 [4.41]	5 [0.20]	70 [2.76]	43 [1.69]	12 [0.47]	3 [0.12]	130 [5.11]
VT018	182 [7.17]	55 [2.17]	112 [4.41]	6 [0.24]	70 [2.76]	59 [2.32]	16 [0.63]	3 [0.12]	160 [6.30]
VT022	220 [8.66]	75 [2.95]	143 [5.63]	7 [0.28]	90 [3.54]	79.5 [3.13]	20 [0.78]	3 [0.12]	180 [7.08]

Part Number	G Pilot Length mm [in.]	P Flange Thickness mm [in.]	H Effective Pilot Length mm [in.]	L Length mm [in.]		C Bolt Circle mm [in.]	D Bolt Hole mm [in.]	O Output Shaft Thread mm [in.]	Q Thread Depth mm [in.]
				4:1 - 10:1	16:1 - 100:1				
VT006	18 [0.71]	7 [0.28]	7 [0.28]	57 [2.24]	105,4 [4.15]	68 [2.68]	5,6 [0.22]	M5	19 [0.75]
VT075	20 [0.79]	8 [0.31]	7 [0.28]	60 [2.36]	117 [4.60]	85 [3.35]	7 [0.28]	M8	19 [0.75]
VT090	12 [0.47]	10 [0.39]	-	68 [2.67]	125 [4.92]	100 [3.94]	6,6 [0.26]	M8	19 [0.75]
VT010	28 [1.10]	10 [0.39]	12 [0.47]	78 [3.09]	146 [5.75]	120 [4.72]	9 [0.34]	M12	20 [0.80]
VT115	12 [0.47]	12 [0.47]	-	94 [3.72]	162 [6.38]	130 [5.118]	9 [0.34]	M12	20 [0.80]
VT014	27 [1.06]	13 [0.51]	14 [0.55]	110,5 [4.35]	195 [7.67]	165 [6.50]	11 [0.43]	M12	20 [0.80]
VT018	27 [1.06]	15 [0.59]	13 [0.51]	136 [5.35]	242.3 [9.54]	215 [8.46]	13,5 [0.53]	M20	42 [1.65]
VT022	35 [1.38]	17 [0.67]	18 [0.71]	142.7 [5.62]	243.6 [9.60]	250 [9.84]	17 [0.67]	M20	42 [1.65]

<sup>1</sup> Ratios are exact, higher ratios are also available, consult factory.  
T<sub>r</sub> = Rated output torque at rated speed for specific hours of life.

T<sub>peak</sub> = Allowable momentary peak torque for emergency stop or heavy shock loading.  
J = Mass moment of inertia reflected to the input shaft (including pinion assembly).



### Helical Right Angle Gearheads

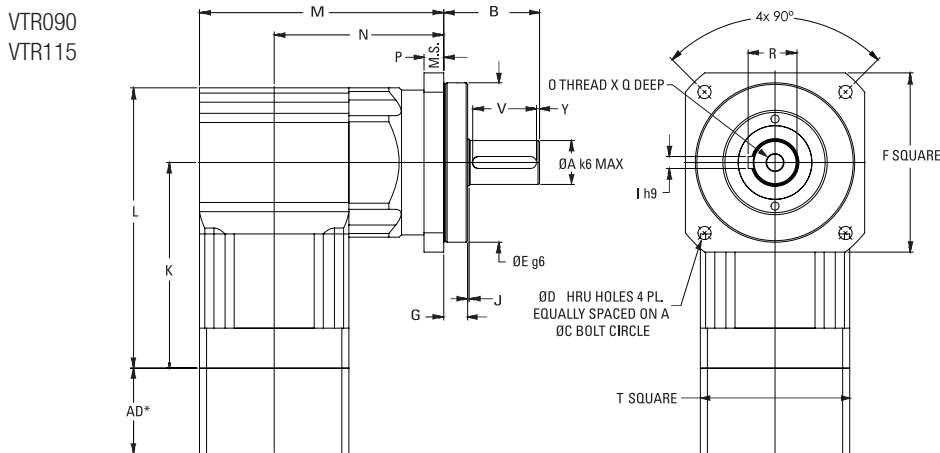
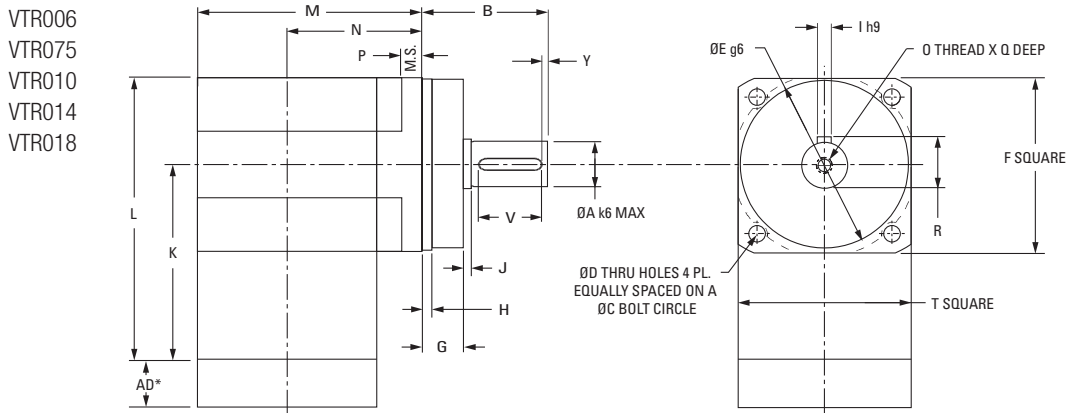

### Right Angle Dimensions

Part Number	F Output Flange Square mm [in.]	A Output Shaft Diameter mm [in.]	B Output Shaft Length mm [in.]	Y Shaft End Distance mm [in.]	V Keyway Length mm [in.]	R Keyway Height mm [in.]	I Key Square mm [in.]	J Shoulder Length mm [in.]	O Output Shaft Thread mm [in.]	Q Thread Depth mm [in.]	E Pilot Diameter mm [in.]	G Pilot Length mm [in.]
VTR006	61 [2.40]	16 [0.63]	48 [1.89]	1 [0.04]	25 [0.98]	18 [0.71]	5 [0.20]	1 [0.04]	M5	19 [0.75]	60 [2.36]	18 [0.71]
VTR075	75 [2.95]	22 [0.86]	56 [2.20]	1,5 [0.06]	32 [1.26]	24,5 [0.97]	6 [0.24]	1 [0.04]	M8	19 [0.75]	70 [2.75]	20 [0.79]
VTR090	90 [3.54]	22 [0.86]	48 [1.89]	1,5 [0.06]	32 [1.26]	24,5 [0.97]	6 [0.24]	1 [0.04]	M8	19 [0.75]	80 [1.48]	12 [0.47]
VTR010	101 [3.98]	32 [1.26]	88 [3.46]	3 [0.12]	50 [1.97]	35 [1.38]	10 [0.39]	2 [0.08]	M12	20 [0.80]	90 [3.54]	28 [1.10]
VTR115	115 [4.53]	32 [1.26]	72 [2.83]	3 [0.12]	50 [1.97]	35 [1.38]	10 [0.39]	2 [0.08]	M12	20 [0.80]	110 [4.33]	24 [0.94]
VTR014	141 [5.55]	40 [1.57]	112 [4.41]	5 [0.20]	70 [2.76]	43 [1.69]	12 [0.47]	3 [0.12]	M12	20 [0.80]	130 [5.11]	27 [1.06]
VTR018	182 [7.17]	55 [2.17]	112 [4.41]	6 [0.24]	70 [2.76]	59 [2.32]	16 [0.63]	3 [0.12]	M20	42 [1.65]	160 [6.29]	27 [1.06]

Part Number	P Flange Thickness mm [in.]	H Effective Pilot Length mm [in.]	L Length mm [in.]	K Distance to Output CL mm [in.]	C Bolt Circle mm [in.]	D Bolt Hole mm [in.]	M Housing Width mm [in.]		N Distance to Input CL mm [in.]		T Input Flange Square mm [in.]
							All other ratios	4:1 & 5:1 only	All other ratios	4:1 & 5:1 only	
VTR006	7 [0.28]	7 [0.28]	109,5 [4.31]	79 [3.11]	68 [2.68]	5,6 [0.22]	95 [3.75]	95 [3.75]	65 [2.55]	65 [2.55]	61 [2.40]
VTR075	8 [0.31]	7 [0.28]	141 [5.55]	103 [4.05]	85 [3.35]	7 [0.28]	114,5 [4.51]	114,5 [4.51]	77 [3.04]	77 [3.04]	75 [2.95]
VTR090	10 [0.39]	-	141 [5.55]	103 [4.05]	100 [3.94]	6,6 [0.26]	122,5 [4.82]	122,5 [4.82]	85 [3.35]	85 [3.35]	75 [2.95]
VTR010	10 [0.39]	12 [0.47]	193 [7.60]	142,5 [5.61]	120 [4.72]	9 [0.34]	149 [5.88]	157 [6.19]	99 [3.89]	107 [4.20]	101 [3.98]
VTR115	12 [0.47]	-	193 [7.60]	142,5 [5.61]	130 [5.118]	9 [0.34]	165 [6.51]	173 [6.82]	114,8 [4.52]	123 [4.83]	101 [3.98]
VTR014	13 [0.51]	14 [0.55]	231 [9.09]	160 [6.23]	165 [6.50]	11 [0.43]	222 [8.74]	222 [8.74]	151 [5.95]	151 [5.95]	142 [5.59]
VTR018	15 [0.59]	13 [0.51]	319 [12.60]	228 [8.97]	215 [8.46]	13,5 [0.53]	273 [10.76]	301 [11.83]	182 [7.18]	210 [8.25]	182 [7.17]

# Micron TRUE Planetary® Gearheads

## ValueTRUE™ Helical True Planetary Gearheads

Inline Torque: VT006 - VT010

### Performance Specifications

Part Number	Ratio	20000 Hour Life			T <sub>peak</sub> Nm [in.-lb.]	J kg-cm <sup>2</sup> [in.-lb.-sec <sup>2</sup> x10 <sup>-4</sup> ]	Torsional Stiffness Nm/arc-min [in.-lb./arc-min]	
		T <sub>r</sub> (1000 rpm) Nm [in.-lb.]	T <sub>r</sub> (3000 rpm) Nm [in.-lb.]	T <sub>r</sub> (5000 rpm) Nm [in.-lb.]				
VT006	VT006-004	4:1	42 [375]	32 [290]	28 [248]	91 [802]	0.20 [1.80]	2.36 [20.9]
	VT006-005	5:1	41 [364]	34 [302]	30 [259]	88 [779]	0.13 [1.16]	2.30 [20.4]
	VT006-007	7:1	40 [347]	36 [319]	32 [276]	84 [743]	0.11 [0.96]	2.18 [19.4]
	VT006-010	10:1	22 [194]	19 [167]	17 [156]	79 [703]	0.10 [0.85]	1.74 [15.4]
	VT006-016	16:1	47 [410]	43 [383]	41 [369]	99 [878]	0.16 [1.44]	2.40 [21.3]
	VT006-020	20:1	47 [416]	44 [42]	42 [375]	100 [887]	0.16 [1.44]	2.36 [20.9]
	VT006-025	25:1	45 [401]	42 [376]	41 [364]	96 [853]	0.16 [1.44]	2.32 [20.5]
	VT006-028	28:1	48 [423]	45 [398]	43 [384]	102 [899]	0.16 [1.44]	2.21 [19.6]
	VT006-035	35:1	46 [408]	43 [384]	42 [127]	97 [864]	0.10 [0.85]	2.29 [20.3]
	VT006-040	40:1	49 [430]	46 [406]	44 [394]	103 [910]	0.10 [0.85]	2.40 [21.3]
VT075	VT075-004	4:1	76 [671]	67 [587]	57 [503]	161 [1423]	0.46 [4.10]	6.30 [55.7]
	VT075-005	5:1	74 [651]	67 [591]	59 [525]	157 [1383]	0.38 [3.40]	6.17 [54.6]
	VT075-007	7:1	70 [621]	64 [569]	61 [541]	149 [1322]	0.31 [2.80]	5.46 [48.3]
	VT075-010	10:1	40 [348]	34 [300]	32 [279]	141 [1254]	0.27 [2.40]	4.01 [35.6]
	VT075-016	16:1	84 [738]	77 [686]	75 [659]	177 [1569]	0.31 [2.80]	6.62 [58.6]
	VT075-020	20:1	85 [747]	79 [698]	76 [671]	179 [1586]	0.31 [2.80]	6.48 [57.3]
	VT075-025	25:1	82 [721]	77 [675]	74 [651]	173 [1528]	0.31 [2.80]	6.36 [56.3]
	VT075-028	28:1	86 [761]	81 [714]	77 [689]	182 [1610]	0.28 [2.50]	5.81 [51.4]
	VT075-035	35:1	83 [734]	78 [690]	76 [667]	175 [1549]	0.16 [1.40]	6.01 [53.2]
	VT075-040	40:1	87 [775]	83 [730]	80 [707]	185 [1632]	0.16 [1.40]	6.63 [58.7]
VT090	VT090-004	4:1	76 [671]	67 [587]	57 [503]	161 [1423]	0.46 [4.10]	6.30 [55.7]
	VT090-005	5:1	74 [651]	67 [591]	59 [525]	157 [1383]	0.38 [3.40]	6.17 [54.6]
	VT090-007	7:1	70 [621]	64 [569]	61 [541]	149 [1322]	0.31 [2.80]	5.46 [48.3]
	VT090-010	10:1	40 [348]	34 [300]	32 [279]	141 [1254]	0.27 [2.40]	4.01 [35.6]
	VT090-016	16:1	84 [738]	77 [686]	75 [659]	177 [1569]	0.31 [2.80]	6.62 [58.6]
	VT090-020	20:1	85 [747]	79 [698]	76 [671]	179 [1586]	0.31 [2.80]	6.48 [57.3]
	VT090-025	25:1	82 [721]	77 [675]	74 [651]	173 [1528]	0.31 [2.80]	6.36 [56.3]
	VT090-028	28:1	86 [761]	81 [714]	77 [689]	182 [1610]	0.28 [2.50]	5.81 [51.4]
	VT090-035	35:1	83 [734]	78 [690]	76 [667]	175 [1549]	0.16 [1.40]	6.01 [53.2]
	VT090-040	40:1	87 [775]	83 [730]	80 [707]	185 [1632]	0.16 [1.40]	6.63 [58.7]
VT010	VT010-004	4:1	221 [1954]	158 [1405]	136 [1206]	463 [4093]	1.58 [14.00]	23.1 [204]
	VT010-005	5:1	216 [1908]	166 [1465]	142 [1257]	451 [3991]	1.36 [12.00]	20.5 [182]
	VT010-007	7:1	206 [1825]	176 [1562]	151 [1340]	433 [3830]	0.97 [8.60]	19.0 [168]
	VT010-010	10:1	115 [1016]	99 [872]	92 [808]	411 [3640]	0.90 [8.00]	13.0 [115]
	VT010-016	16:1	246 [2174]	227 [2010]	206 [1827]	518 [4577]	1.10 [9.70]	24.6 [218]
	VT010-020	20:1	249 [2205]	231 [2046]	221 [1954]	524 [4637]	1.10 [9.70]	21.9 [194]
	VT010-025	25:1	241 [2131]	224 [1985]	216 [1908]	506 [4477]	1.10 [9.70]	21.9 [194]
	VT010-028	28:1	254 [2248]	237 [2098]	228 [2018]	533 [4718]	0.94 [8.30]	19.0 [168]
	VT010-035	35:1	246 [2172]	230 [2033]	221 [1959]	514 [4549]	0.79 [7.00]	18.8 [167]
	VT010-040	40:1	259 [2291]	243 [2149]	234 [2075]	542 [4794]	0.79 [7.00]	24.7 [219]

<sup>1</sup> Ratios are exact, higher ratios are also available, consult factory.  
T<sub>r</sub> = Rated output torque at rated speed for specific hours of life.

T<sub>peak</sub> = Allowable momentary peak torque for emergency stop or heavy shock loading.  
J = Mass moment of inertia reflected to the input shaft (including pinion assembly).

## ValueTRUE Helical True Planetary Gearheads

Inline Torque: VT115 - VT022

### Performance Specifications

Part Number	Ratio	20000 Hour Life			T <sub>peak</sub> Nm [in.-lb.]	J kg-cm <sup>2</sup> [in.-lb.-sec <sup>2</sup> x10 <sup>-4</sup> ]	Torsional Stiffness Nm/arc-min [in.-lb./arc-min]	
		T <sub>r</sub> (1000 rpm) Nm [in.-lb.]	T <sub>r</sub> (3000 rpm) Nm [in.-lb.]	T <sub>r</sub> (5000 rpm) Nm [in.-lb.]				
VT115	VT115-004	4:1	221 [1954]	158 [1405]	136 [1206]	463 [4093]	1.58 [14.00]	23.1 [204]
	VT115-005	5:1	216 [1908]	166 [1465]	142 [1257]	451 [3991]	1.36 [12.00]	20.5 [182]
	VT115-007	7:1	206 [1825]	176 [1562]	151 [1340]	433 [3830]	0.97 [8.60]	19.0 [168]
	VT115-010	10:1	115 [1016]	99 [872]	92 [808]	411 [3640]	0.90 [8.00]	13.0 [115]
	VT115-016	16:1	246 [2174]	227 [2010]	206 [1827]	518 [4577]	1.10 [9.70]	24.6 [218]
	VT115-020	20:1	249 [2205]	231 [2046]	221 [1954]	524 [4637]	1.10 [9.70]	21.9 [194]
	VT115-025	25:1	241 [2131]	224 [1985]	216 [1908]	506 [4477]	1.10 [9.70]	21.9 [194]
	VT115-028	28:1	254 [2248]	237 [2098]	228 [2018]	533 [4718]	0.94 [8.30]	19.0 [168]
	VT115-035	35:1	246 [2172]	230 [2033]	221 [1959]	514 [4549]	0.79 [7.00]	18.8 [167]
	VT115-040	40:1	259 [2291]	243 [2149]	234 [2075]	542 [4794]	0.79 [7.00]	24.7 [219]
VT014	VT014-004	4:1	518 [4583]	387 [3427]	332 [2940]	1066 [9431]	6.51 [57.60]	49.5 [438]
	VT014-005	5:1	504 [4459]	403 [3571]	347 [3064]	1040 [9206]	5.02 [44.40]	45.9 [407]
	VT014-007	7:1	483 [4274]	430 [3809]	369 [3268]	1002 [8866]	3.80 [33.60]	42.3 [378]
	VT014-010	10:1	275 [2426]	235 [2075]	217 [1919]	956 [8459]	3.39 [30.00]	31.5 [280]
	VT014-016	16:1	579 [5119]	532 [4704]	503 [4456]	1206 [10674]	4.21 [37.20]	52.2 [463]
	VT014-020	20:1	587 [5195]	542 [4795]	518 [4583]	1224 [10832]	4.07 [36.00]	48.6 [431]
	VT014-025	25:1	567 [5021]	526 [4654]	504 [4459]	1183 [10463]	4.07 [36.00]	48.6 [431]
	VT014-028	28:1	599 [5303]	556 [4926]	534 [4725]	1248 [11047]	3.53 [31.20]	42.3 [375]
	VT014-035	35:1	579 [5122]	539 [4774]	518 [4589]	1204 [10653]	2.99 [26.40]	39.6 [352]
	VT014-040	40:1	612 [5413]	572 [5055]	550 [4867]	1271 [11248]	2.99 [26.40]	52.2 [461]
VT018	VT018-004	4:1	1203 [10649]	866 [7658]	743 [6570]	2242 [21609]	25.90 [229.00]	137.7 [1222]
	VT018-005	5:1	1174 [10385]	902 [7981]	774 [6847]	2389 [21143]	20.00 [177.00]	135 [1197]
	VT018-007	7:1	1128 [9878]	962 [8512]	825 [7303]	2309 [20429]	14.60 [129.00]	120.6 [1067]
	VT018-010	10:1	645 [5710]	550 [4864]	507 [4486]	2210 [19561]	13.00 [115.00]	90.9 [804]
	VT018-016	16:1	1356 [12005]	1238 [10963]	1125 [9959]	2800 [24779]	16.10 [142.00]	144.9 [1286]
	VT018-020	20:1	1378 [12194]	1265 [11191]	1203 [10649]	2846 [25187]	15.60 [138.00]	140.4 [1244]
	VT018-025	25:1	1333 [11799]	1229 [10877]	1174 [10385]	2754 [24370]	15.60 [138.00]	117.9 [1044]
	VT018-028	28:1	1409 [12466]	1301 [11518]	1245 [11013]	2910 [25751]	13.50 [119.00]	124.2 [1103]
	VT018-035	35:1	1362 [120490]	1263 [11178]	1211 [10714]	2810 [24870]	11.40 [101.00]	111.6 [988]
	VT018-040	40:1	1439 [12739]	1338 [11846]	1285 [11371]	2970 [2611]	11.40 [101.00]	144.9 [1286]
VT022	VT022-004	4:1	1815 [16065]	1306 [11554]	1121 [9913]	4180 [36986]	87.00 [7.70]	386 [3414]
	VT022-005	5:1	1892 [16740]	1360 [12038]	1167 [10328]	4093 [36225]	73.40 [6.50]	372 [3295]
	VT022-007	7:1	1838 [16268]	1452 [12844]	1245 [11019]	3933 [34804]	62.60 [5.55]	326 [2891]
	VT022-010	10:1	1050 [9293]	893 [8097]	823 [7277]	3871 [34254]	56.90 [5.04]	227 [2012]
	VT022-016	16:1	2218 [19625]	1979 [17513]	1697 [15025]	4722 [41793]	87.30 [7.73]	392 [3472]
	VT022-020	20:1	2254 [19948]	2062 [18246]	1815 [16065]	4791 [42396]	73.60 [6.52]	392 [3470]
	VT022-025	25:1	2184 [19332]	2009 [17781]	1892 [16745]	4636 [41025]	73.10 [6.47]	376 [3329]
	VT022-028	28:1	2304 [20394]	2125 [18803]	2008 [17528]	4884 [43224]	62.70 [5.55]	391 [3469]
	VT022-035	35:1	2233 [19765]	2067 [18294]	1976 [17494]	4719 [41757]	62.50 [5.53]	376 [3328]
	VT022-040	40:1	2357 [20864]	2188 [19359]	2095 [18542]	4972 [43999]	57.20 [5.06]	391 [3466]

<sup>1</sup> Ratios are exact, higher ratios are also available, consult factory.  
T<sub>r</sub> = Rated output torque at rated speed for specific hours of life.

T<sub>peak</sub> = Allowable momentary peak torque for emergency stop or heavy shock loading.  
J = Mass moment of inertia reflected to the input shaft (including pinion assembly).

# Micron TRUE Planetary® Gearheads

## ValueTRUE™ Helical Right Angle Gearheads

Right Angle Torque: VTR006 - VTR075

### Performance Specifications

Part Number	Ratio	20000 Hour Life			T <sub>peak</sub> Nm [in.-lb.]	J kg-cm <sup>2</sup> [in.-lb.-sec <sup>2</sup> x10 <sup>-4</sup> ]	Torsional Stiffness Nm/arc-min [in.-lb./arc-min]	
		T <sub>r</sub> (1000 rpm) Nm [in.-lb.]	T <sub>r</sub> (3000 rpm) Nm [in.-lb.]	T <sub>r</sub> (5000 rpm) Nm [in.-lb.]				
VTR006	VTR006-008	8:1	44 [390]	41 [358]	34 [303]	95 [844]	0.50 [4.43]	1.89 [16.7]
	VTR006-010	10:1	43 [382]	40 [350]	36 [319]	92 [812]	0.49 [4.34]	1.62 [14.3]
	VTR006-012	12:1	41 [358]	37 [327]	33 [295]	98 [868]	0.39 [3.45]	1.80 [15.9]
	VTR006-014	14:1	41 [358]	38 [335]	37 [327]	87 [773]	0.49 [4.34]	2.16 [19.1]
	VTR006-015	15:1	44 [390]	41 [366]	40 [350]	95 [836]	0.39 [3.45]	2.16 [19.1]
	VTR006-016	16:1	30 [263]	27 [239]	24 [215]	99 [876]	0.39 [3.45]	2.16 [19.1]
	VTR006-020	20:1	37 [327]	34 [303]	31 [271]	95 [844]	0.39 [3.45]	2.16 [19.1]
	VTR006-025	25:1	31 [271]	28 [247]	25 [223]	96 [852]	0.38 [3.36]	2.07 [18.3]
	VTR006-028	28:1	42 [374]	40 [350]	39 [342]	90 [797]	0.39 [3.45]	1.98 [18.3]
	VTR006-030	30:1	25 [223]	22 [191]	21 [183]	84 [741]	0.42 [3.72]	2.07 [18.3]
	VTR006-035	35:1	43 [382]	40 [350]	35 [311]	91 [804]	0.38 [3.36]	2.07 [18.3]
	VTR006-040	40:1	26 [231]	23 [199]	22 [191]	85 [749]	0.39 [3.45]	2.16 [19.1]
VTR006-050	50:1	27 [239]	23 [207]	22 [191]	85 [749]	0.38 [3.36]	2.16 [19.1]	
VTR075	VTR075-008	8:1	80 [709]	73 [645]	70 [621]	170 [1505]	1.90 [16.81]	4.23 [37.4]
	VTR075-010	10:1	77 [685]	71 [629]	68 [605]	165 [1458]	1.90 [16.81]	3.69 [32.7]
	VTR075-012	12:1	82 [725]	76 [669]	73 [645]	175 [1545]	1.50 [13.28]	4.14 [36.6]
	VTR075-014	14:1	74 [653]	68 [605]	66 [581]	157 [1386]	1.90 [16.81]	5.94 [52.6]
	VTR075-015	15:1	79 [701]	74 [653]	70 [621]	168 [1489]	1.50 [13.28]	6.03 [53.4]
	VTR075-016	16:1	84 [741]	77 [685]	75 [661]	177 [1569]	1.50 [13.28]	6.03 [53.4]
	VTR075-020	20:1	80 [709]	75 [661]	72 [637]	171 [1513]	1.50 [13.28]	5.85 [51.8]
	VTR075-025	25:1	82 [725]	77 [677]	72 [637]	173 [1529]	1.50 [13.28]	5.76 [51.0]
	VTR075-028	28:1	77 [677]	72 [637]	69 [613]	161 [1426]	1.50 [13.28]	5.31 [47.0]
	VTR075-030	30:1	45 [398]	40 [350]	37 [327]	149 [1322]	1.60 [14.16]	5.67 [47.0]
	VTR075-035	35:1	77 [685]	73 [645]	70 [621]	163 [1442]	1.50 [13.28]	5.67 [50.2]
	VTR075-040	40:1	47 [414]	41 [358]	38 [335]	151 [1338]	1.50 [13.28]	6.03 [53.4]
VTR075-050	50:1	48 [422]	42 [374]	40 [350]	153 [1354]	1.50 [13.28]	5.94 [52.6]	

All ratios in frame size 60, 75, 100 and 140 are available to ship in 24 hours through the Gearhead Express Program.

<sup>1</sup> Ratios are exact, higher ratios are also available, consult factory.  
T<sub>r</sub> = Rated output torque at rated speed for specific hours of life.

T<sub>peak</sub> = Allowable momentary peak torque for emergency stop or heavy shock loading.  
J = Mass moment of inertia reflected to the input shaft (including pinion assembly).

## ValueTRUE Helical Right Angle Gearheads

Right Angle Torque: VTR090 - VTR010

### Performance Specifications

Part Number	Ratio	20000 Hour Life			T <sub>peak</sub> Nm [in.-lb.]	J kg-cm <sup>2</sup> [in.-lb.-sec <sup>2</sup> x10 <sup>-4</sup> ]	Torsional Stiffness Nm/arc-min [in.-lb./arc-min]	
		T <sub>r</sub> (1000 rpm) Nm [in.-lb.]	T <sub>r</sub> (3000 rpm) Nm [in.-lb.]	T <sub>r</sub> (5000 rpm) Nm [in.-lb.]				
VTR090	VTR090-008	8:1	80 [709]	73 [345]	70 [621]	170 [1505]	1.90 [16.81]	4.23 [37.4]
	VTR090-010	10:1	77 [685]	71 [629]	68 [605]	165 [1458]	1.90 [16.81]	3.69 [32.7]
	VTR090-012	12:1	82 [725]	76 [669]	73 [645]	175 [1545]	1.50 [13.28]	4.14 [36.6]
	VTR090-014	14:1	74 [653]	68 [605]	66 [581]	157 [1386]	1.90 [16.81]	5.94 [52.6]
	VTR090-015	15:1	79 [701]	74 [653]	70 [621]	168 [1489]	1.50 [13.28]	6.03 [53.4]
	VTR090-016	16:1	84 [741]	77 [685]	75 [661]	177 [1569]	1.50 [13.28]	6.03 [53.4]
	VTR090-020	20:1	80 [709]	75 [661]	72 [637]	171 [1513]	1.50 [13.28]	5.85 [51.8]
	VTR090-025	25:1	82 [725]	77 [677]	72 [637]	173 [1529]	1.50 [13.28]	5.76 [51.0]
	VTR090-028	28:1	77 [677]	72 [637]	69 [613]	161 [1426]	1.50 [13.28]	5.31 [47.0]
	VTR090-030	30:1	45 [398]	40 [350]	37 [327]	149 [1322]	1.60 [14.16]	5.67 [50.2]
	VTR090-035	35:1	77 [685]	73 [645]	70 [621]	163 [1442]	1.50 [13.28]	5.67 [50.2]
	VTR090-040	40:1	47 [414]	41 [358]	38 [335]	151 [1338]	1.50 [13.28]	6.03 [53.4]
VTR090-050	50:1	48 [422]	42 [374]	40 [350]	153 [1354]	1.50 [13.28]	5.94 [52.6]	
VTR010	VTR010-004T	4:1	234 [2071]	195 [1728]	167 [1673]	492 [4357]	3.30 [29.20]	14.94 [132.2]
	VTR010-005T	5:1	228 [2015]	203 [1800]	175 [1649]	478 [4229]	3.30 [29.20]	11.79 [104.3]
	VTR010-008	8:1	234 [2071]	195 [1728]	167 [1673]	492 [4357]	3.30 [29.20]	14.94 [132.2]
	VTR010-010	10:1	228 [2015]	203 [1800]	175 [1649]	478 [4229]	3.30 [29.20]	11.79 [104.3]
	VTR010-012	12:1	243 [2151]	221 [1951]	189 [1744]	508 [4492]	2.60 [23.01]	16.92 [149.7]
	VTR010-014	14:1	217 [1920]	200 [1768]	186 [1649]	455 [4030]	3.30 [29.20]	20.79 [184.0]
	VTR010-015	15:1	233 [2063]	216 [1912]	197 [1744]	491 [4349]	2.50 [22.12]	21.87 [193.5]
	VTR010-016	16:1	225 [1991]	205 [1816]	185 [1641]	518 [4580]	2.60 [23.01]	22.32 [197.5]
	VTR010-020	20:1	238 [2103]	221 [1951]	212 [1872]	500 [4421]	2.60 [23.01]	19.89 [176.0]
	VTR010-025	25:1	211 [1864]	193 [1705]	174 [1532]	506 [4476]	2.50 [22.12]	19.89 [176.0]
	VTR010-028	28:1	226 [1999]	211 [1854]	203 [1792]	473 [4190]	2.60 [23.01]	17.28 [152.9]
	VTR010-030	30:1	132 [1171]	115 [1020]	107 [948]	439 [3887]	2.80 [24.78]	17.19 [152.9]
	VTR010-035	35:1	229 [2023]	214 [1896]	206 [1824]	479 [4237]	2.50 [22.12]	17.10 [152.1]
	VTR010-040	40:1	137 [1211]	119 [1051]	112 [988]	445 [3935]	2.60 [23.01]	22.41 [198.3]
	VTR010-050	50:1	140 [1243]	122 [1083]	115 [1020]	448 [3967]	2.50 [22.12]	19.71 [174.4]

All ratios in frame size 60, 75, 100 and 140 are available to ship in 24 hours through the Gearhead Express Program.

<sup>1</sup> Ratios are exact, higher ratios are also available, consult factory.  
T<sub>r</sub> = Rated output torque at rated speed for specific hours of life.

T<sub>peak</sub> = Allowable momentary peak torque for emergency stop or heavy shock loading.  
J = Mass moment of inertia reflected to the input shaft (including pinion assembly).

# Micron TRUE Planetary® Gearheads

## ValueTRUE™ Helical Right Angle Gearheads

Right Angle Torque: VTR115, VTR014, VTR018

### Performance Specifications

Part Number	Ratio	20000 Hour Life			T <sub>peak</sub> Nm [in.-lb.]	J kg-cm <sup>2</sup> [in.-lb.-sec <sup>2</sup> x10 <sup>-4</sup> ]	Torsional Stiffness Nm/arc-min [in.-lb./arc-min]	
		T <sub>r</sub> (1000 rpm) Nm [in.-lb.]	T <sub>r</sub> (3000 rpm) Nm [in.-lb.]	T <sub>r</sub> (5000 rpm) Nm [in.-lb.]				
VTR115	VTR115-004T	4:1	234 [2071]	195 [1728]	167 [1481]	492 [4357]	3.30 [29.20]	14.94 [132.2]
	VTR115-005T	5:1	228 [2015]	203 [1800]	175 [1545]	478 [4229]	3.30 [29.20]	11.79 [104.3]
	VTR115-008	8:1	234 [2071]	195 [1728]	167 [1481]	492 [4357]	3.30 [29.20]	14.94 [132.2]
	VTR115-010	10:1	228 [2015]	203 [1800]	175 [1545]	478 [4229]	3.30 [29.20]	11.79 [104.3]
	VTR115-012	12:1	243 [2151]	221 [1951]	189 [1673]	508 [4492]	2.60 [23.01]	16.92 [149.7]
	VTR115-014	14:1	217 [1920]	200 [1768]	186 [1649]	455 [4030]	3.30 [29.20]	20.79 [184.0]
	VTR115-015	15:1	233 [2063]	216 [1912]	197 [1744]	491 [4349]	2.50 [22.12]	21.87 [193.5]
	VTR115-016	16:1	225 [1991]	205 [1816]	185 [1641]	518 [4580]	2.60 [23.01]	22.32 [197.3]
	VTR115-020	20:1	238 [2103]	221 [1951]	212 [1872]	500 [4421]	2.60 [23.01]	19.89 [176.0]
	VTR115-025	25:1	211 [1864]	193 [1705]	174 [1537]	506 [4476]	2.50 [22.12]	19.89 [176.0]
	VTR115-028	28:1	226 [1999]	211 [1864]	203 [1792]	473 [4190]	2.60 [23.01]	17.28 [152.9]
	VTR115-030	30:1	132 [1171]	115 [1020]	107 [948]	439 [3887]	2.80 [24.78]	17.19 [152.1]
	VTR115-035	35:1	229 [2023]	214 [1896]	203 [1824]	479 [4237]	2.50 [22.12]	17.10 [151.3]
	VTR115-040	40:1	137 [1211]	119 [1051]	112 [988]	445 [3935]	2.60 [23.01]	22.41 [198.3]
	VTR115-050	50:1	140 [1243]	122 [1083]	115 [1020]	448 [3967]	2.50 [22.12]	19.71 [174.4]
VTR014	VTR014-004T	4:1	550 [4867]	477 [4221]	409 [3616]	1142 [10108]	16.00 [141.60]	33.03 [292.0]
	VTR014-005T	5:1	534 [4723]	485 [4293]	427 [3775]	1110 [9821]	16.00 [141.60]	28.71 [254.0]
	VTR014-008	8:1	550 [4867]	477 [4221]	409 [3616]	1142 [10108]	16.00 [141.60]	33.03 [292.0]
	VTR014-010	10:1	534 [4723]	485 [4293]	427 [3775]	1110 [9821]	16.00 [141.60]	28.71 [254.0]
	VTR014-012	12:1	567 [5018]	518 [4580]	462 [4086]	1182 [10458]	13.00 [115.05]	19.89 [176.0]
	VTR014-014	14:1	509 [4500]	466 [4126]	444 [3927]	1061 [9391]	16.00 [141.60]	46.44 [411.0]
	VTR014-015	15:1	549 [4859]	504 [4460]	480 [4245]	1145 [10131]	12.00 [106.20]	46.53 [412.0]
	VTR014-016	16:1	525 [4644]	479 [4237]	433 [3831]	1206 [10673]	13.00 [115.05]	47.52 [421.0]
	VTR014-020	20:1	560 [4954]	517 [4572]	493 [4365]	1166 [10323]	13.00 [115.05]	44.28 [392.0]
	VTR014-025	25:1	532 [4707]	494 [4373]	474 [4198]	1183 [10466]	13.00 [115.05]	38.52 [341.0]
	VTR014-028	28:1	532 [4707]	494 [4373]	474 [4198]	1108 [9805]	13.00 [115.05]	38.52 [341.0]
	VTR014-030	30:1	317 [2804]	275 [2429]	256 [2262]	1029 [9104]	14.00 [123.90]	40.23 [356.0]
	VTR014-035	35:1	539 [4771]	502 [4444]	483 [4277]	1121 [9924]	12.00 [106.20]	36.18 [320.0]
	VTR014-040	40:1	328 [2899]	285 [2525]	266 [2350]	1043 [9231]	13.00 [115.05]	47.34 [419.0]
	VTR014-050	50:1	338 [2987]	293 [2597]	275 [2429]	1054 [9327]	12.00 [106.20]	44.28 [392.0]
VTR018	VTR018-004T	4:1	1285 [11374]	1066 [9431]	914 [8092]	2636 [23329]	45 [398]	102 [900]
	VTR018-005T	5:1	1247 [11039]	1111 [9829]	952 [8427]	2566 [22708]	45 [398]	83 [733]
	VTR018-008	8:1	1285 [11374]	1066 [9431]	914 [8092]	2636 [23329]	45 [398]	102 [900]
	VTR018-010	10:1	1247 [11039]	1111 [9829]	952 [8427]	2566 [22708]	45 [398]	83 [733]
	VTR018-012	12:1	1328 [11748]	1203 [10649]	1032 [9136]	2736 [24214]	36 [319]	57 [502]
	VTR018-014	14:1	1193 [10554]	1085 [9606]	1016 [8992]	2460 [21768]	45 [398]	100 [884]
	VTR018-015	15:1	1287 [11390]	1174 [10386]	1076 [9518]	2655 [23497]	35 [310]	130 [1147]
	VTR018-016	16:1	1199 [10609]	1094 [9685]	989 [8754]	2800 [24779]	36 [319]	132 [1171]
	VTR018-020	20:1	1314 [11629]	1205 [10665]	1148 [10155]	2713 [24007]	36 [319]	128 [1131]
	VTR018-025	25:1	1054 [9327]	962 [8515]	870 [7702]	2754 [24373]	35 [310]	107 [948]
	VTR018-028	28:1	1251 [11071]	1156 [10227]	1105 [9781]	2583 [22860]	36 [319]	113 [1004]
	VTR018-030	30:1	747 [6611]	645 [5711]	600 [5313]	2399 [21227]	38 [336]	102 [900]
	VTR018-035	35:1	1268 [11223]	1176 [10410]	1128 [9980]	2617 [23162]	35 [310]	102 [900]
	VTR018-040	40:1	775 [6858]	671 [5942]	626 [5536]	2437 [21569]	36 [319]	132 [1171]
	VTR018-050	50:1	796 [7048]	691 [6117]	645 [5711]	2465 [21816]	35 [310]	128 [1131]

All ratios in frame size 60, 75, 100 and 140 are available to ship in 24 hours through the Gearhead Express Program.

<sup>1</sup> Ratios are exact, higher ratios are also available, consult factory.  
T<sub>r</sub> = Rated output torque at rated speed for specific hours of life.

T<sub>peak</sub> = Allowable momentary peak torque for emergency stop or heavy shock loading.  
J = Mass moment of inertia reflected to the input shaft (including pinion assembly).

## Radial and Axial Load Ratings

### VT006

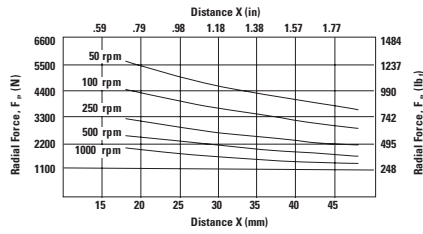
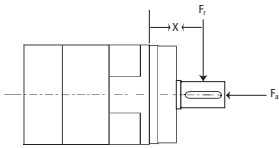

Speed rpm	Axial Load, F <sub>a</sub> N [lb <sub>f</sub> ]
50	7198 [1618]
100	5710 [1284]
250	4208 [946]
500	3342 [751]
1000	2652 [596]

### VT075 and VT090

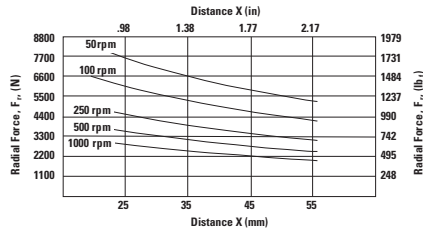
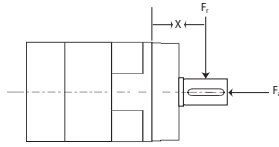

Speed rpm	Axial Load, F <sub>a</sub> N [lb <sub>f</sub> ]
50	9903 [2227]
100	7863 [1768]
250	5793 [1303]
500	4599 [1034]
1000	3650 [821]

### VT010 and VT115

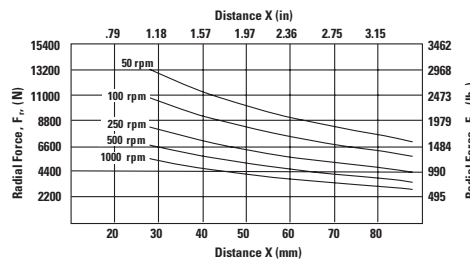
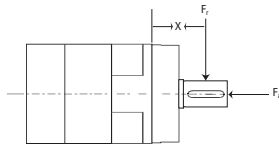

Speed rpm	Axial Load, F <sub>a</sub> N [lb <sub>f</sub> ]
50	13,675 [3075]
100	11,107 [2497]
250	8435 [1897]
500	6855 [1542]
1000	5568 [1252]

### VT014

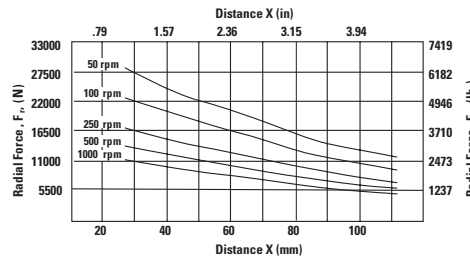
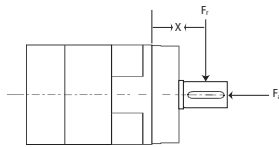

Speed rpm	Axial Load, F <sub>a</sub> N [lb <sub>f</sub> ]
50	25,374 [5705]
100	20,609 [4633]
250	15,657 [3520]
500	12,716 [2859]
1000	10,329 [2322]

### VT018

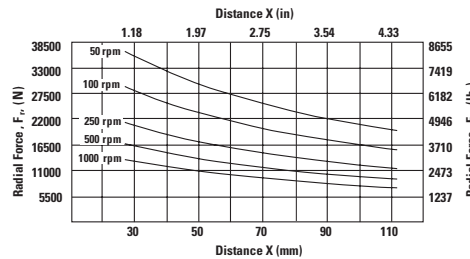
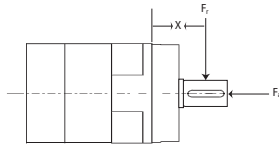

Speed rpm	Axial Load, F <sub>a</sub> N [lb <sub>f</sub> ]
50	34,538 [7765]
100	27,414 [6163]
250	20,197 [4541]
500	16,034 [3605]
1000	12,726 [2861]

### VT022

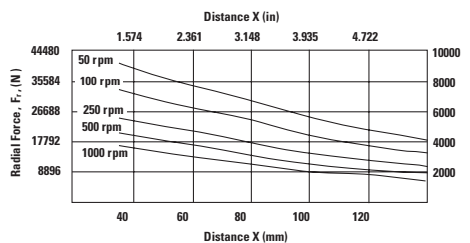
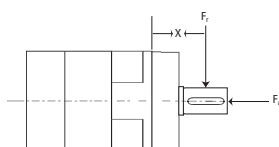

Speed rpm	Axial Load, F <sub>a</sub> N [lb <sub>f</sub> ]
50	32,351 [3655]
100	26,277 [2969]
250	19,962 [2256]
500	16,214 [1832]

These graphs display the allowable radial load at a given distance (X) from the mounting surface based on an L<sub>10</sub> life of 10,000 hours for the mean output speed n<sub>mount</sub>, as described on page 9.

# Micron TRUE Planetary® Gearheads

## Radial and Axial Load Ratings

### VTR006

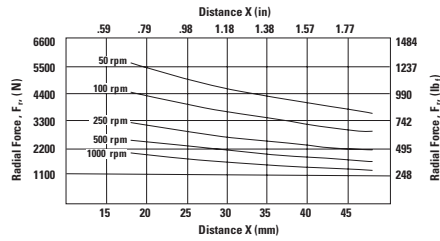
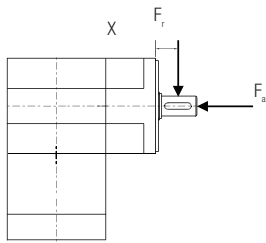

Speed rpm	Axial Load, $F_a$ N [lb]
50	7198 [1618]
100	5710 [1284]
250	4208 [946]
500	3342 [751]
1000	2652 [596]

### VTR075 and VTR090

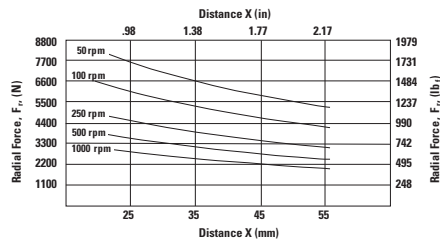
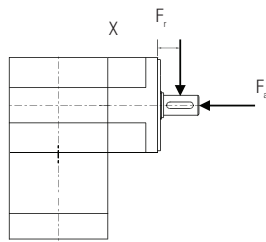

Speed rpm	Axial Load, $F_a$ N [lb]
50	9903 [2227]
100	7863 [1768]
250	5793 [1303]
500	4599 [1034]
1000	3650 [821]

### VTR010 and VTR115

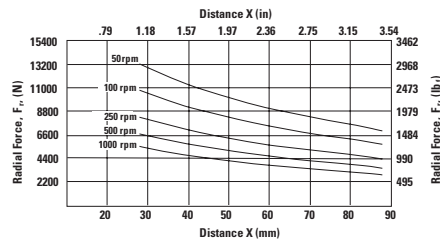
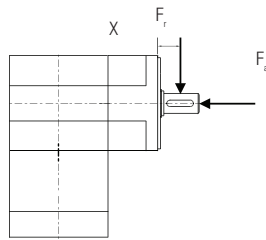

Speed rpm	Axial Load, $F_a$ N [lb]
50	13,675 [3075]
100	11,107 [2497]
250	8435 [1897]
500	6855 [1542]
1000	5568 [1252]

### VTR014

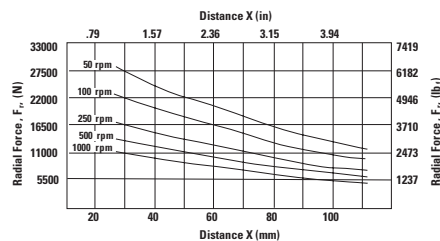
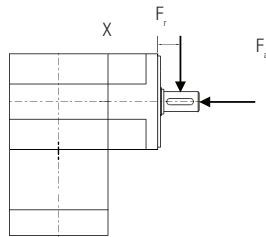

Speed rpm	Axial Load, $F_a$ N [lb]
50	25,374 [5705]
100	20,609 [4633]
250	15,657 [3520]
500	12,716 [2859]
1000	10,329 [2322]

### VTR018

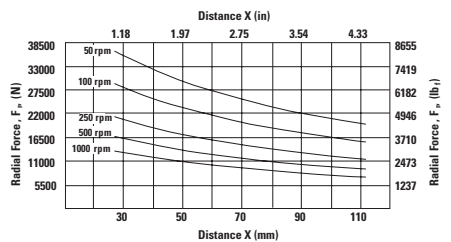
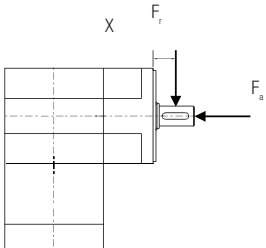

Speed rpm	Axial Load, $F_a$ N [lb]
50	34,538 [7765]
100	27,414 [6163]
250	20,197 [4541]
500	16,034 [3605]
1000	12,726 [2861]

These graphs display the allowable radial load at a given distance (X) from the mounting surface based on an  $L_{10}$  life of 10,000 hours for the mean output speed  $n_{\text{out}}$ , as described on page 9.



# Micron TRUE Planetary® Gearheads

## DuraTRUE 90 Size 142H (Hollow Shaft)

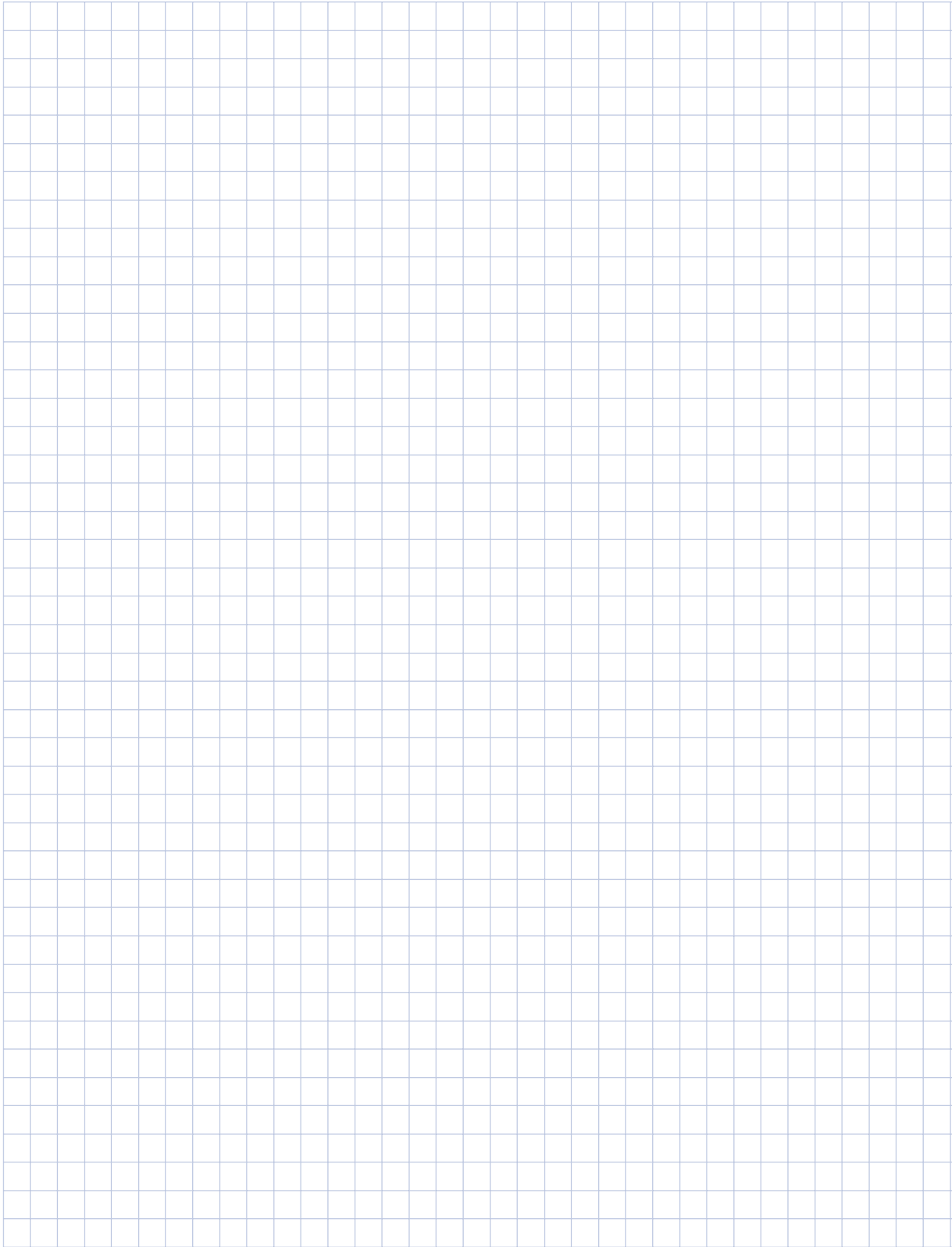

# Micron TRUE Planetary® Gearheads

## UltraTRUE™

### Helical True Planetary Gearheads

#### Ready for Immediate Delivery

<b>Precision</b>	4 arc-minutes
<b>Frame Sizes</b>	60 mm, 75 mm, 90 mm, 100 mm, 115 mm, 140 mm, 180 mm and 220 mm
<b>Torque Capacity</b>	up to 3300 Nm
<b>Ratio Availability</b>	4:1 thru 100:1
<b>Radial load capacity</b>	up to 37910 N
<b>Mounting System</b>	RediMount™

- 1 Tapered roller bearings**  
provide high axial and radial load carrying capacity
- 2 Helical crowned**  
HRC 55-60 steel gears  
provide higher torque capacity and smoother operation
- 3 Sealed deep groove ball bearing**  
provides high radial load carrying capability
- 4 RediMount system**  
provides error-free motor installation
- 5 Single-piece output**  
integrated output housing and internal gear
- 6 Anodized aluminum housing**  
reduces weight and prevents corrosion

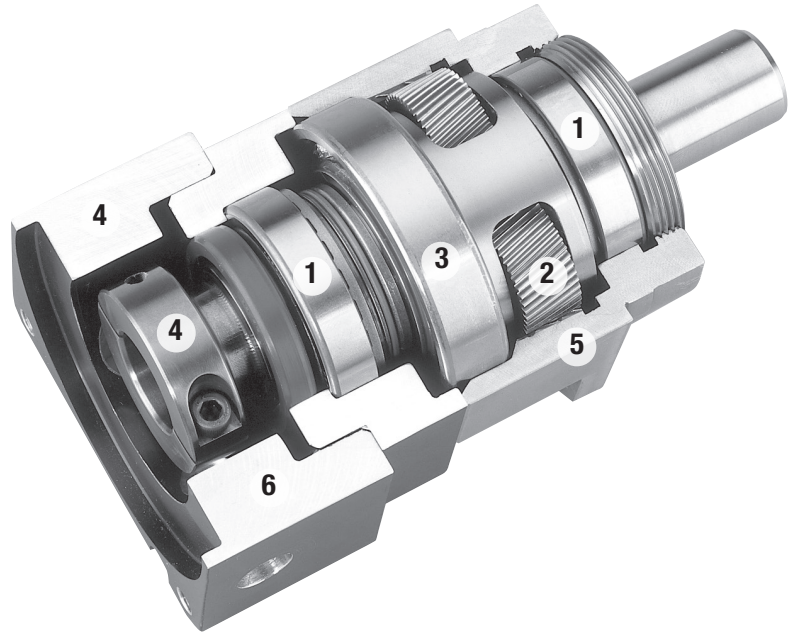

*Micron True Planetary® Gearheads  
shipped within 24 hours!*

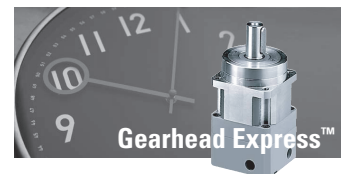

*Need it fast? Go to the back cover  
of the catalog for details.*

### Helical True Planetary Gearheads

Metric

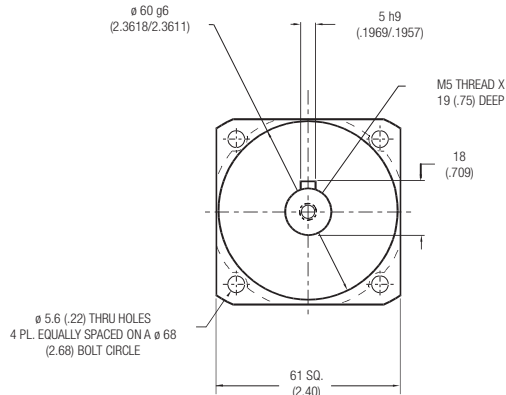
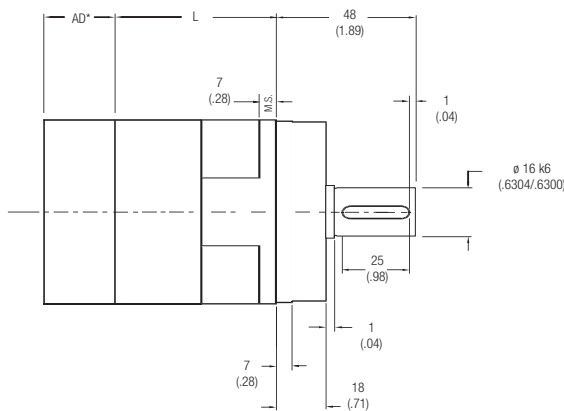

Ratio <sup>1</sup>	Dimension 'L' mm [in.]	Backlash [arc-min]	Weight kg [lb.]	Efficiency
4:1 to 10:1	57 [2.25]	4 max	2 [4.4]	95%
16:1 to 100:1	105,4 [4.15]	5 max	2.5 [5.5]	90%

All dimensions are: mm (in.)  
 AD\*\* = Adapter length  
 Adapter length will vary depending on motor.  
 M.S. = Mounting Surface  
 Efficiency is calculated at 100% of the rated torque.

### Performance Specifications

Part Number	Ratio <sup>1</sup>	10,000 Hour Life			T peak Nm [in.-lb.]	20,000 Hour Life			J kg-cm <sup>2</sup> [in.-lb.-sec <sup>2</sup> ×10 <sup>-4</sup> ]	Torsional Stiffness Nm/arc-min [in.-lb./arc-min]
		T <sub>r</sub> (1000 rpm) Nm [in.-lb.]	T <sub>r</sub> (3000 rpm) Nm [in.-lb.]	T <sub>r</sub> (5000 rpm) Nm [in.-lb.]		T <sub>r</sub> (1000 rpm) Nm [in.-lb.]	T <sub>r</sub> (3000 rpm) Nm [in.-lb.]	T <sub>r</sub> (5000 rpm) Nm [in.-lb.]		
UT006-004	4:1	48 [426]	44 [387]	38 [340]	101 [891]	47 [417]	36 [322]	31 [276]	.20 [1.80]	2.62 [23.2]
UT006-005	5:1	47 [413]	43 [377]	40 [355]	98 [865]	46 [404]	38 [336]	33 [288]	.13 [1.16]	2.56 [22.7]
UT006-007	7:1	45 [394]	41 [362]	39 [345]	93 [825]	44 [385]	40 [354]	35 [307]	.11 [96]	2.42 [21.5]
UT006-010	10:1	26 [232]	23 [200]	21 [186]	88 [781]	24 [215]	21 [185]	19 [173]	.10 [85]	1.93 [17.1]
UT006-016	16:1	53 [467]	49 [435]	47 [419]	110 [975]	52 [456]	48 [426]	46 [410]	.16 [1.44]	2.67 [23.7]
UT006-020	20:1	53 [472]	50 [442]	48 [426]	111 [985]	52 [462]	49 [432]	47 [417]	.16 [1.44]	2.62 [23.2]
UT006-025	25:1	51 [456]	48 [428]	47 [413]	107 [948]	50 [446]	47 [418]	46 [404]	.16 [1.44]	2.58 [22.8]
UT006-028	28:1	54 [481]	51 [452]	49 [437]	113 [999]	53 [470]	50 [442]	48 [427]	.16 [1.44]	2.46 [21.8]
UT006-035	35:1	52 [463]	49 [437]	48 [423]	108 [960]	51 [453]	48 [427]	47 [414]	.10 [85]	2.54 [22.5]
UT006-040	40:1	55 [489]	52 [462]	51 [447]	114 [1011]	54 [478]	51 [451]	49 [438]	.10 [85]	2.67 [23.7]
UT006-050	50:1	53 [471]	50 [446]	49 [433]	110 [971]	52 [461]	49 [436]	48 [423]	.10 [85]	2.62 [23.2]
UT006-070	70:1	50 [445]	48 [423]	46 [411]	103 [913]	49 [435]	47 [414]	45 [402]	.10 [85]	2.46 [21.8]
UT006-100	100:1	35 [307]	30 [269]	29 [253]	96 [851]	32 [284]	28 [249]	26 [234]	.10 [85]	2.03 [17.9]

All ratios are available to ship in 24 hours through the Gearhead Express Program.

<sup>1</sup> Ratios are exact, higher ratios are also available, consult factory.  
 T<sub>r</sub> = Rated output torque at rated speed for specific hours of life.

T<sub>peak</sub> = Allowable momentary peak torque for emergency stop or heavy shock loading.  
 J = Mass moment of inertia reflected to the input shaft (including pinion assembly).

# Micron TRUE Planetary® Gearheads

## UltraTRUE™ Size 75

### Helical True Planetary Gearheads

Metric

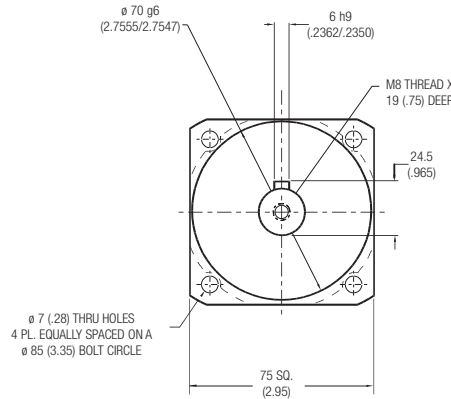
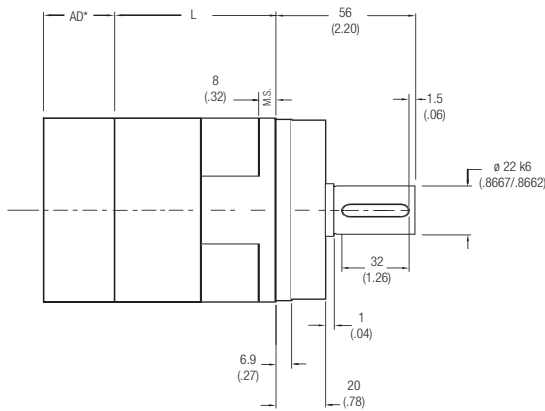

Ratio <sup>1</sup>	Dimension 'L' mm [in.]	Backlash [arc-min]	Weight kg [lb.]	Efficiency
4:1 to 10:1	60 [2.35]	4 max	2.5 [5.5]	95%
16:1 to 100:1	117 [4.60]	5 max	3.0 [6.6]	90%

All dimensions are: mm (in.)  
 AD\*\* = Adapter length  
 Adapter length will vary depending on motor.  
 M.S. = Mounting Surface  
 Efficiency is calculated at 100% of the rated torque.

### Performance Specifications

Part Number	Ratio <sup>1</sup>	10,000 Hour Life			T peak Nm [in.-lb.]	20,000 Hour Life			J kg-cm <sup>2</sup> [in.-lb.-sec <sup>2</sup> ×10 <sup>-4</sup> ]	Torsional Stiffness Nm/arc-min [in.-lb./arc-min]
		T <sub>r</sub> (1000 rpm) Nm [in.-lb.]	T <sub>r</sub> (3000 rpm) Nm [in.-lb.]	T <sub>r</sub> (5000 rpm) Nm [in.-lb.]		T <sub>r</sub> (1000 rpm) Nm [in.-lb.]	T <sub>r</sub> (3000 rpm) Nm [in.-lb.]	T <sub>r</sub> (5000 rpm) Nm [in.-lb.]		
UT075-004	4:1	86 [762]	78 [689]	73 [649]	179 [1581]	84 [746]	74 [652]	63 [559]	.46 [ 4.1]	7,00 [61.9]
UT075-005	5:1	84 [740]	76 [672]	72 [636]	174 [1537]	82 [723]	74 [657]	66 [583]	.38 [ 3.4]	6,86 [60.7]
UT075-007	7:1	80 [706]	73 [646]	69 [615]	166 [1469]	78 [690]	71 [632]	68 [601]	.31 [ 2.8]	6,07 [53.7]
UT075-010	10:1	47 [418]	41 [360]	38 [335]	157 [1393]	44 [387]	38 [333]	35 [310]	.27 [ 2.4]	4,46 [39.5]
UT075-016	16:1	95 [838]	88 [780]	85 [749]	197 [1743]	93 [820]	86 [762]	83 [732]	.31 [ 2.8]	7,36 [65.1]
UT075-020	20:1	96 [849]	90 [792]	86 [762]	199 [1762]	94 [830]	88 [775]	84 [746]	.31 [ 2.8]	7,20 [63.7]
UT075-025	25:1	93 [820]	87 [767]	84 [740]	192 [1698]	91 [801]	85 [750]	82 [723]	.31 [ 2.8]	7,07 [62.6]
UT075-028	28:1	98 [864]	92 [811]	88 [782]	202 [1789]	96 [845]	90 [793]	86 [765]	.28 [ 2.5]	6,45 [57.1]
UT075-035	35:1	94 [834]	89 [784]	86 [758]	194 [1721]	92 [815]	87 [767]	84 [741]	.16 [ 1.4]	6,68 [59.1]
UT075-040	40:1	99 [880]	94 [829]	91 [802]	205 [1813]	97 [861]	92 [811]	89 [785]	.16 [ 1.4]	7,37 [65.2]
UT075-050	50:1	96 [849]	91 [801]	88 [777]	197 [1743]	94 [830]	89 [784]	86 [759]	.16 [ 1.4]	7,22 [63.9]
UT075-070	70:1	91 [802]	86 [760]	83 [738]	185 [1639]	89 [784]	84 [743]	82 [722]	.16 [ 1.4]	6,48 [57.3]
UT075-100	100:1	63 [554]	55 [486]	52 [456]	173 [1529]	58 [513]	51 [450]	48 [422]	.15 [ 1.3]	4,50 [39.8]

All ratios are available to ship in 24 hours through the Gearhead Express Program.

<sup>1</sup> Ratios are exact, higher ratios are also available, consult factory.  
 T<sub>r</sub> = Rated output torque at rated speed for specific hours of life.

T<sub>peak</sub> = Allowable momentary peak torque for emergency stop or heavy shock loading.  
 J = Mass moment of inertia reflected to the input shaft (including pinion assembly).

### Helical True Planetary Gearheads

Metric

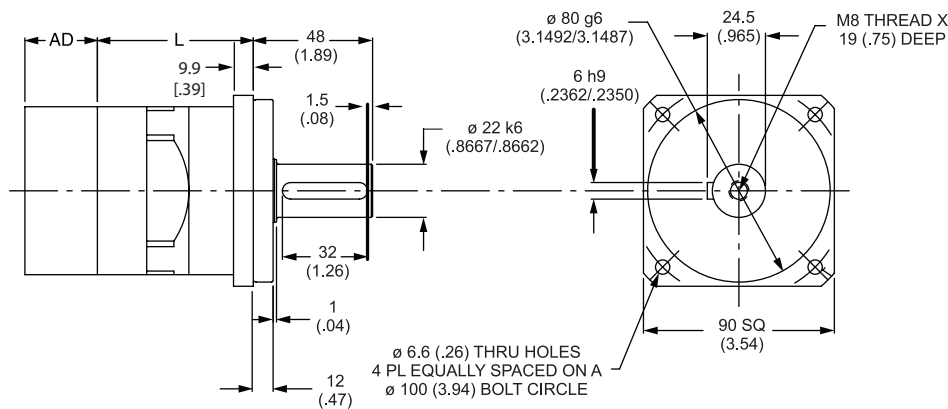

Ratio <sup>1</sup>	Dimension 'L' mm [in.]	Backlash [arc-min]	Weight kg [lb.]	Efficiency
4:1 to 10:1	68 [2.66]	4 max	2,5 [5.5]	95%
16:1 to 100:1	125 [4.91]	5 max	3,0 [6.6]	90%

All dimensions are: mm (in.)

AD\*\* = Adapter length

Adapter length and width will vary depending on motor.

M.S. = Mounting Surface

Efficiency is calculated at 100% of the rated torque.

### Performance Specifications

Part Number	Ratio <sup>1</sup>	10,000 Hour Life				T peak Nm [in.-lb.]	20,000 Hour Life			J kg-cm <sup>2</sup> [in.-lb.-sec <sup>2</sup> x10 <sup>-4</sup> ]	Torsional Stiffness Nm/arc-min [in.-lb./arc-min]
		T <sub>r</sub> (1000 rpm) Nm [in.-lb.]	T <sub>r</sub> (3000 rpm) Nm [in.-lb.]	T <sub>r</sub> (5000 rpm) Nm [in.-lb.]	T <sub>r</sub> (1000 rpm) Nm [in.-lb.]		T <sub>r</sub> (3000 rpm) Nm [in.-lb.]	T <sub>r</sub> (5000 rpm) Nm [in.-lb.]			
UT090-004	4:1	86 [762]	78 [689]	73 [649]	179 [1581]	84 [746]	74 [652]	63 [559]	,46 [4.1]	7,00 [61.9]	
UT090-005	5:1	84 [740]	76 [672]	72 [636]	174 [1537]	82 [723]	74 [657]	66 [583]	,38 [3.4]	6,86 [60.7]	
UT090-007	7:1	80 [706]	73 [646]	69 [615]	166 [1469]	78 [690]	71 [632]	68 [601]	,31 [2.8]	6,07 [53.7]	
UT090-010	10:1	47 [418]	41 [360]	38 [335]	157 [1393]	44 [387]	38 [333]	35 [310]	,27 [2.4]	4,46 [39.5]	
UT090-016	16:1	95 [838]	88 [780]	85 [749]	197 [1743]	93 [820]	86 [762]	83 [732]	,31 [2.8]	7,36 [65.1]	
UT090-020	20:1	96 [849]	90 [792]	86 [762]	199 [1762]	94 [830]	88 [775]	84 [746]	,31 [2.8]	7,20 [63.7]	
UT090-025	25:1	93 [820]	87 [767]	84 [740]	192 [1698]	91 [801]	85 [750]	82 [723]	,31 [2.8]	7,07 [62.6]	
UT090-028	28:1	98 [864]	92 [811]	88 [782]	202 [1789]	96 [845]	90 [793]	86 [765]	,28 [2.5]	6,45 [57.1]	
UT090-035	35:1	94 [834]	89 [784]	86 [758]	194 [1721]	92 [815]	87 [767]	84 [741]	,16 [1.4]	6,68 [59.1]	
UT090-040	40:1	99 [880]	94 [829]	91 [802]	205 [1813]	97 [861]	92 [811]	89 [785]	,16 [1.4]	7,37 [65.2]	
UT090-050	50:1	96 [849]	91 [801]	88 [777]	197 [1743]	94 [830]	89 [784]	86 [759]	,16 [1.4]	7,22 [63.9]	
UT090-070	70:1	91 [802]	86 [760]	83 [738]	185 [1639]	89 [784]	84 [743]	82 [722]	,16 [1.4]	6,48 [57.3]	
UT090-100	100:1	63 [554]	55 [486]	52 [456]	173 [1529]	58 [513]	51 [450]	48 [422]	,15 [1.3]	4,50 [39.8]	

All ratios are available to ship in 24 hours through the Gearhead Express Program.

<sup>1</sup> Ratios are exact, higher ratios are also available, consult factory.  
T<sub>r</sub> = Rated output torque at rated speed for specific hours of life.

T<sub>peak</sub> = Allowable momentary peak torque for emergency stop or heavy shock loading.  
J = Mass moment of inertia reflected to the input shaft (including pinion assembly).

# Micron TRUE Planetary® Gearheads

## UltraTRUE™ Size 10

### Helical True Planetary Gearheads

Metric

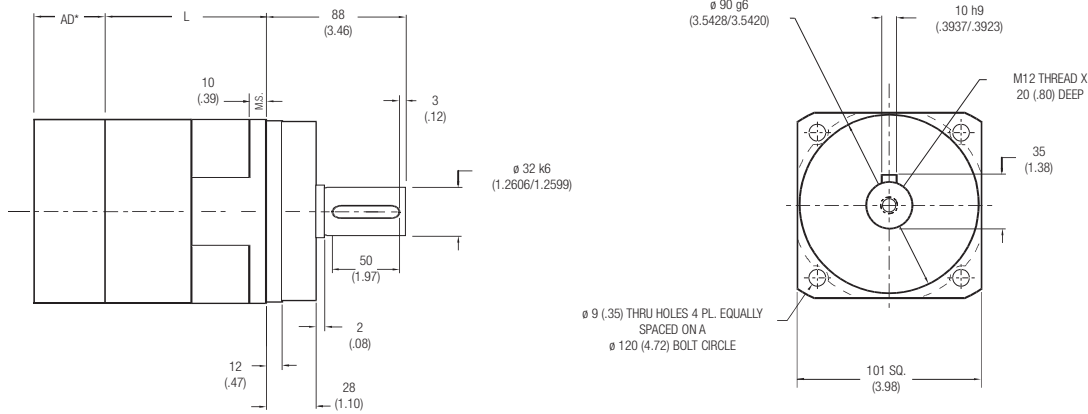

Ratio <sup>1</sup>	Dimension 'L' mm [in.]	Backlash [arc-min]	Weight kg [lb.]	Efficiency
4:1 to 10:1	78 [3.07]	4 max	6 [13]	95%
16:1 to 100:1	146 [5.75]	5 max	8 [18]	90%

All dimensions are: mm (in.)  
 AD\*\* = Adapter length  
 Adapter length and width will vary depending on motor.  
 M.S. = Mounting Surface  
 Efficiency is calculated at 100% of the rated torque.

### Performance Specifications

Part Number	Ratio <sup>1</sup>	10,000 Hour Life			T peak Nm [in.-lb.]	20,000 Hour Life			J kg-cm <sup>2</sup> [in.-lb.-sec <sup>2</sup> x10 <sup>-4</sup> ]	Torsional Stiffness Nm/arc-min [in.-lb./arc-min]
		T <sub>r</sub> (1000 rpm) Nm [in.-lb.]	T <sub>r</sub> (3000 rpm) Nm [in.-lb.]	T <sub>r</sub> (5000 rpm) Nm [in.-lb.]		T <sub>r</sub> (1000 rpm) Nm [in.-lb.]	T <sub>r</sub> (3000 rpm) Nm [in.-lb.]	T <sub>r</sub> (5000 rpm) Nm [in.-lb.]		
UT010-004	4:1	252 [2229]	217 [1922]	186 [1649]	514 [4548]	245 [2171]	176 [1561]	151 [1340]	1,58 [14.0]	25,7 [227]
UT010-005	5:1	245 [2168]	220 [1950]	194 [1720]	501 [4434]	240 [2120]	184 [1628]	158 [1397]	1,36 [12.0]	22,8 [202]
UT010-007	7:1	234 [2074]	213 [1882]	201 [1780]	481 [4256]	229 [2028]	196 [1736]	168 [1489]	,97 [8.6]	21,1 [187]
UT010-010	10:1	138 [1220]	118 [1048]	110 [971]	457 [4044]	128 [1129]	110 [969]	102 [898]	,90 [8.0]	14,4 [128]
UT010-016	16:1	279 [2471]	258 [2284]	247 [2184]	575 [5085]	273 [2416]	252 [2233]	229 [2030]	1,10 [9.7]	27,3 [242]
UT010-020	20:1	283 [2505]	263 [2325]	252 [2229]	582 [5152]	277 [2450]	257 [2273]	245 [2171]	1,10 [9.7]	24,3 [215]
UT010-025	25:1	274 [2422]	255 [2256]	245 [2168]	562 [4974]	268 [2368]	249 [2206]	240 [2120]	1,10 [9.7]	24,3 [215]
UT010-028	28:1	289 [2554]	269 [2384]	259 [2293]	592 [5242]	282 [2498]	263 [2331]	253 [2242]	,94 [8.3]	21,1 [187]
UT010-035	35:1	279 [2468]	261 [2310]	252 [2227]	571 [5054]	273 [2413]	255 [2259]	246 [2177]	,79 [7.0]	20,9 [185]
UT010-040	40:1	294 [2604]	276 [2442]	266 [2357]	602 [5327]	288 [2546]	270 [2388]	260 [2305]	,79 [7.0]	27,4 [243]
UT010-050	50:1	284 [2514]	267 [2364]	258 [2286]	579 [5128]	278 [2458]	261 [2312]	253 [2235]	,78 [6.9]	24,1 [213]
UT010-070	70:1	269 [2380]	254 [2246]	246 [2177]	546 [4832]	263 [2327]	248 [2197]	241 [2129]	,78 [6.9]	21,1 [187]
UT010-100	100:1	184 [1626]	161 [1423]	151 [1335]	510 [4510]	170 [1504]	149 [1317]	140 [1235]	,78 [6.9]	17,2 [152]

All ratios are available to ship in 24 hours through the Gearhead Express Program.

<sup>1</sup> Ratios are exact, higher ratios are also available, consult factory.  
 T<sub>r</sub> = Rated output torque at rated speed for specific hours of life.

T<sub>peak</sub> = Allowable momentary peak torque for emergency stop or heavy shock loading.  
 J = Mass moment of inertia reflected to the input shaft (including pinion assembly).

### Helical True Planetary Gearheads

Metric

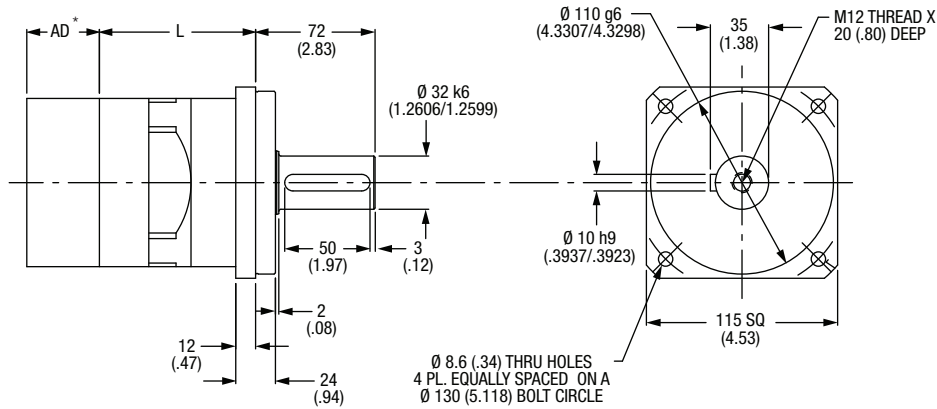

Ratio <sup>1</sup>	Dimension 'L' mm [in.]	Backlash [arc-min]	Weight kg [lb.]	Efficiency
4:1 to 10:1	94 [3.70]	4 max	6 [13]	95%
16:1 to 100:1	162 [6.38]	5 max	6 [18]	88%

All dimensions are: mm (in.)  
 AD\*\* = Adapter length  
 Adapter length and width will vary depending on motor.  
 M.S. = Mounting Surface  
 Efficiency is calculated at 100% of the rated torque.

### Performance Specifications

Part Number	Ratio <sup>1</sup>	10,000 Hour Life			T <sub>peak</sub> Nm [in.-lb.]	20,000 Hour Life			J kg-cm <sup>2</sup> [in.-lb.-sec <sup>2</sup> ×10 <sup>-4</sup> ]	Torsional Stiffness Nm/arc-min [in.-lb./arc-min]
		T <sub>r</sub> (1000 rpm) Nm [in.-lb.]	T <sub>r</sub> (3000 rpm) Nm [in.-lb.]	T <sub>r</sub> (5000 rpm) Nm [in.-lb.]		T <sub>r</sub> (1000 rpm) Nm [in.-lb.]	T <sub>r</sub> (3000 rpm) Nm [in.-lb.]	T <sub>r</sub> (5000 rpm) Nm [in.-lb.]		
UT115-004	4:1	252 [2229]	217 [1922]	186 [1649]	514 [4548]	245 [2171]	176 [1561]	151 [1340]	1,58 [14.0]	25,7 [227]
UT115-005	5:1	245 [2168]	220 [1950]	194 [1720]	501 [4434]	240 [2120]	184 [1628]	158 [1397]	1,36 [12.0]	22,8 [202]
UT115-007	7:1	234 [2074]	213 [1882]	201 [1780]	481 [4256]	229 [2028]	196 [1736]	168 [1489]	,97 [8.6]	21,1 [187]
UT115-010	10:1	138 [1220]	118 [1048]	110 [971]	457 [4044]	128 [1129]	110 [969]	102 [898]	,90 [8.0]	14,4 [128]
UT115-016	16:1	279 [2471]	258 [2284]	247 [2184]	575 [5085]	273 [2416]	252 [2233]	229 [2030]	1,10 [9.7]	27,3 [242]
UT115-020	20:1	283 [2505]	263 [2325]	252 [2229]	582 [5152]	277 [2450]	257 [2273]	245 [2171]	1,10 [9.7]	24,3 [215]
UT115-025	25:1	274 [2422]	255 [2256]	245 [2168]	562 [4974]	268 [2368]	249 [2206]	240 [2120]	1,10 [9.7]	24,3 [215]
UT115-028	28:1	289 [2554]	269 [2384]	259 [2293]	592 [5242]	282 [2498]	263 [2331]	253 [2242]	,94 [8.3]	21,1 [187]
UT115-035	35:1	279 [2468]	261 [2310]	252 [2227]	571 [5054]	273 [2413]	255 [2259]	246 [2177]	,79 [7.0]	20,9 [185]
UT115-040	40:1	294 [2604]	276 [2442]	266 [2357]	602 [5327]	288 [2546]	270 [2388]	260 [2305]	,79 [7.0]	27,4 [243]
UT115-050	50:1	284 [2514]	267 [2364]	258 [2286]	579 [5128]	278 [2458]	261 [2312]	253 [2235]	,78 [6.9]	24,1 [213]
UT115-070	70:1	269 [2380]	254 [2246]	246 [2177]	546 [4832]	263 [2327]	248 [2197]	241 [2129]	,78 [6.9]	21,1 [187]
UT115-100	100:1	184 [1626]	161 [1423]	151 [1335]	510 [4510]	170 [1504]	149 [1317]	140 [1235]	,78 [6.9]	17,2 [152]

All ratios are available to ship in 24 hours through the Gearhead Express Program.

<sup>1</sup> Ratios are exact, higher ratios are also available, consult factory.  
 T<sub>r</sub> = Rated output torque at rated speed for specific hours of life.

T<sub>peak</sub> = Allowable momentary peak torque for emergency stop or heavy shock loading.  
 J = Mass moment of inertia reflected to the input shaft (including pinion assembly).

# Micron TRUE Planetary® Gearheads

## UltraTRUE™ Size 14

### Helical True Planetary Gearheads

Metric

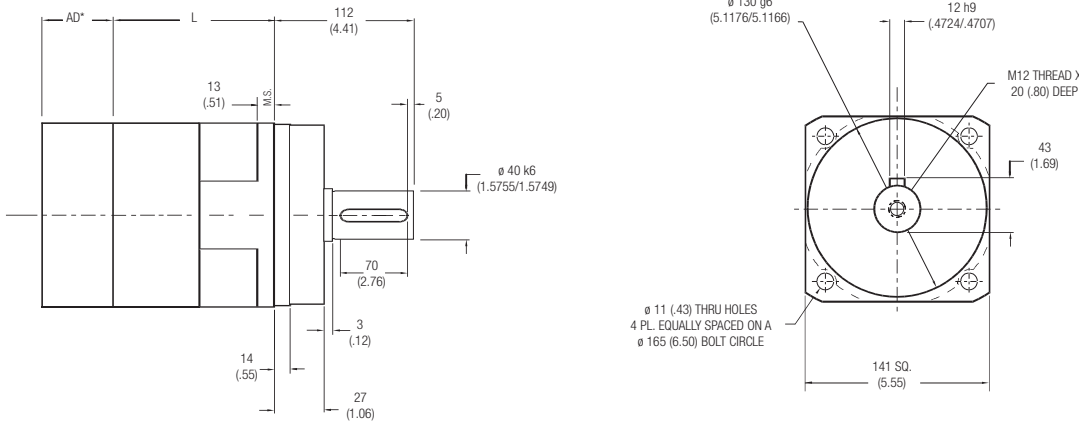

Ratio <sup>1</sup>	Dimension 'L' mm [in.]	Backlash [arc-min]	Weight kg [lb.]	Efficiency
4:1 to 10:1	110,5 [4.35]	4 max	14 [31]	95%
16:1 to 100:1	195 [7.69]	5 max	18 [40]	90%

All dimensions are: mm (in.)  
 AD\*\* = Adapter length  
 Adapter length and width will vary depending on motor.  
 M.S. = Mounting Surface  
 Efficiency is calculated at 100% of the rated torque.

### Performance Specifications

Part Number	Ratio <sup>1</sup>	10,000 Hour Life			T peak Nm [in.-lb.]	20,000 Hour Life			J kg-cm <sup>2</sup> [in.-lb.-sec <sup>2</sup> x10 <sup>-4</sup> ]	Torsional Stiffness Nm/arc-min [in.-lb./arc-min]
		T <sub>r</sub> (1000 rpm) Nm [in.-lb.]	T <sub>r</sub> (3000 rpm) Nm [in.-lb.]	T <sub>r</sub> (5000 rpm) Nm [in.-lb.]		T <sub>r</sub> (1000 rpm) Nm [in.-lb.]	T <sub>r</sub> (3000 rpm) Nm [in.-lb.]	T <sub>r</sub> (5000 rpm) Nm [in.-lb.]		
UT014-004	4:1	588 [5207]	521 [4613]	454 [4022]	1184 [10,479]	575 [5092]	430 [3808]	369 [3267]	6,51 [57.6]	55 [487]
UT014-005	5:1	572 [5066]	511 [4519]	474 [4191]	1156 [10,229]	560 [4954]	448 [3968]	385 [3404]	5,02 [44.4]	51 [452]
UT014-007	7:1	549 [4857]	494 [4375]	466 [4120]	1113 [9851]	537 [4749]	478 [4232]	410 [3631]	3,80 [33.6]	47 [420]
UT014-010	10:1	329 [2913]	282 [2492]	260 [2304]	1062 [9399]	305 [2696]	261 [2306]	241 [2132]	3,39 [30.0]	35 [311]
UT014-016	16:1	657 [5817]	604 [5346]	576 [5095]	1340 [11,860]	643 [5688]	591 [5227]	559 [4951]	4,21 [37.2]	58 [514]
UT014-020	20:1	667 [5902]	616 [5449]	588 [5207]	1360 [12,035]	652 [5772]	602 [5328]	575 [5092]	4,07 [36.0]	54 [479]
UT014-025	25:1	645 [5706]	598 [5288]	572 [5066]	1314 [11,625]	630 [5579]	584 [5171]	560 [4954]	4,07 [36.0]	54 [479]
UT014-028	28:1	681 [6026]	632 [5597]	607 [5369]	1387 [12,274]	666 [5892]	618 [5473]	593 [5250]	3,53 [31.2]	47 [417]
UT014-035	35:1	658 [5820]	613 [5424]	589 [5215]	1338 [11,837]	643 [5691]	599 [5304]	576 [5099]	2,99 [26.4]	44 [391]
UT014-040	40:1	695 [6150]	649 [5745]	625 [5530]	1412 [12,498]	680 [6014]	635 [5617]	611 [5408]	2,99 [26.4]	58 [512]
UT014-050	50:1	671 [5935]	628 [5560]	606 [5363]	1360 [12,034]	656 [5803]	614 [5437]	593 [5244]	2,85 [25.2]	54 [479]
UT014-070	70:1	635 [5623]	598 [5291]	578 [5118]	1283 [11,359]	621 [5499]	585 [5174]	565 [5004]	2,85 [25.2]	49 [435]
UT014-100	100:1	441 [3898]	385 [3407]	361 [3193]	1201 [10,627]	408 [3607]	356 [3153]	334 [2954]	2,85 [25.2]	35 [312]

All ratios are available to ship in 24 hours through the Gearhead Express Program.

<sup>1</sup> Ratios are exact, higher ratios are also available, consult factory.  
 T<sub>r</sub> = Rated output torque at rated speed for specific hours of life.

T<sub>peak</sub> = Allowable momentary peak torque for emergency stop or heavy shock loading.  
 J = Mass moment of inertia reflected to the input shaft (including pinion assembly).



### Helical True Planetary Gearheads

Metric

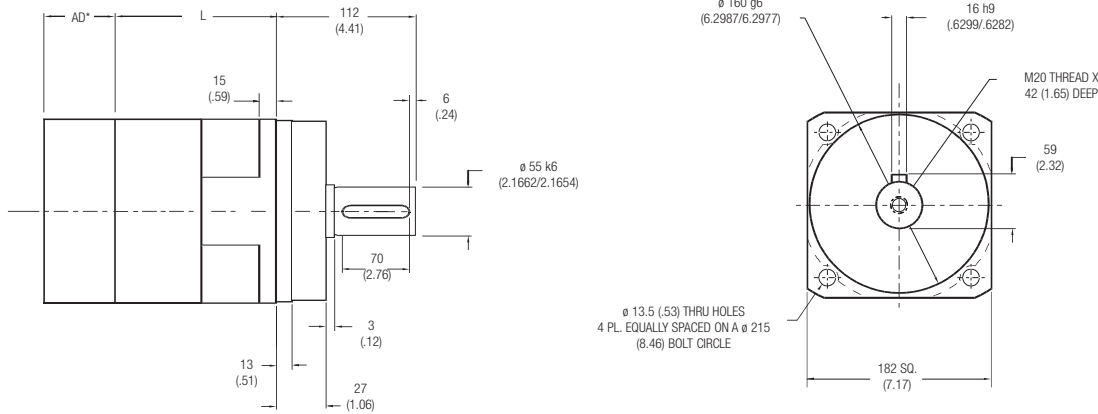

Ratio <sup>1</sup>	Dimension 'L' in. [mm]	Backlash [arc-min]	Weight kg [lb.]	Efficiency
4:1 to 10:1	136 [5.35]	4 max	40 [88]	95%
16:1 to 100:1	242 [9.54]	5 max	45 [99]	90%

All dimensions are: mm (in.)  
 AD\*\* = Adapter length  
 Adapter length and width will vary depending on motor.  
 M.S. = Mounting Surface  
 Efficiency is calculated at 100% of the rated torque.

### Performance Specifications

Part Number	Ratio <sup>1</sup>	10,000 Hour Life			T <sub>peak</sub> Nm [in.-lb.]	20,000 Hour Life			J kg-cm <sup>2</sup> [in.-lb.-sec <sup>2</sup> x10 <sup>-4</sup> ]	Torsional Stiffness Nm/arc-min [in.-lb./arc-min]
		T <sub>r</sub> (1000 rpm) Nm [in.-lb.]	T <sub>r</sub> (3000 rpm) Nm [in.-lb.]	T <sub>r</sub> (5000 rpm) Nm [in.-lb.]		T <sub>r</sub> (1000 rpm) Nm [in.-lb.]	T <sub>r</sub> (3000 rpm) Nm [in.-lb.]	T <sub>r</sub> (5000 rpm) Nm [in.-lb.]		
UT018-004	4:1	1368 [12108]	1184 [10476]	1016 [8988]	2713 [24010]	1337 [11832]	962 [8509]	825 [7300]	25,9 [229]	153 [1358]
UT018-005	5:1	1333 [11800]	1179 [10430]	1058 [9366]	2654 [23492]	1304 [11539]	1002 [8868]	860 [7608]	20,0 [177]	150 [1330]
UT018-007	7:1	1281 [11338]	1144 [10128]	1073 [9494]	2565 [22699]	1253 [11087]	1069 [9458]	917 [8114]	14,6 [129]	134 [1185]
UT018-010	10:1	775 [6856]	660 [5841]	609 [5387]	2456 [21734]	717 [6344]	611 [5404]	563 [4984]	13,0 [115]	101 [893]
UT018-016	16:1	1541 [13641]	1408 [12457]	1336 [11827]	3111 [27532]	1507 [13339]	1376 [12181]	1250 [11065]	16,1 [142]	161 [1429]
UT018-020	20:1	1566 [13855]	1437 [12716]	1368 [12108]	3162 [27986]	1531 [13549]	1405 [12434]	1337 [11832]	15,6 [138]	156 [1382]
UT018-025	25:1	1515 [13407]	1396 [12359]	1333 [11800]	3060 [27078]	1481 [13110]	1366 [12085]	1304 [11539]	15,6 [138]	131 [1160]
UT018-028	28:1	1600 [14164]	1479 [13088]	1414 [12515]	3233 [28612]	1565 [13851]	1446 [12798]	1383 [12237]	13,5 [119]	138 [1225]
UT018-035	35:1	1547 [13691]	1435 [12701]	1376 [12174]	3122 [27633]	1513 [13388]	1403 [12420]	1345 [11904]	11,4 [101]	124 [1098]
UT018-040	40:1	1636 [14475]	1521 [13460]	1460 [12920]	3300 [29201]	1599 [14154]	1487 [13162]	1428 [12634]	11,4 [101]	161 [1429]
UT018-050	50:1	1579 [13978]	1474 [13042]	1418 [12547]	3181 [28153]	1544 [13668]	1441 [12754]	1386 [12269]	10,9 [96]	156 [1382]
UT018-070	70:1	1498 [13256]	1404 [12429]	1355 [11993]	3008 [26621]	1465 [12963]	1373 [12154]	1325 [11728]	10,9 [96]	138 [1225]
UT018-100	100:1	1042 [9218]	909 [8043]	851 [7528]	2819 [24949]	964 [8529]	841 [7442]	787 [6966]	10,9 [96]	103 [908]

<sup>1</sup> Ratios are exact, higher ratios are also available, consult factory.  
 T<sub>r</sub> = Rated output torque at rated speed for specific hours of life.

T<sub>peak</sub> = Allowable momentary peak torque for emergency stop or heavy shock loading.  
 J = Mass moment of inertia reflected to the input shaft (including pinion assembly).

# Micron TRUE Planetary® Gearheads

## UltraTRUE™ Size 22

### Helical True Planetary Gearheads

Metric

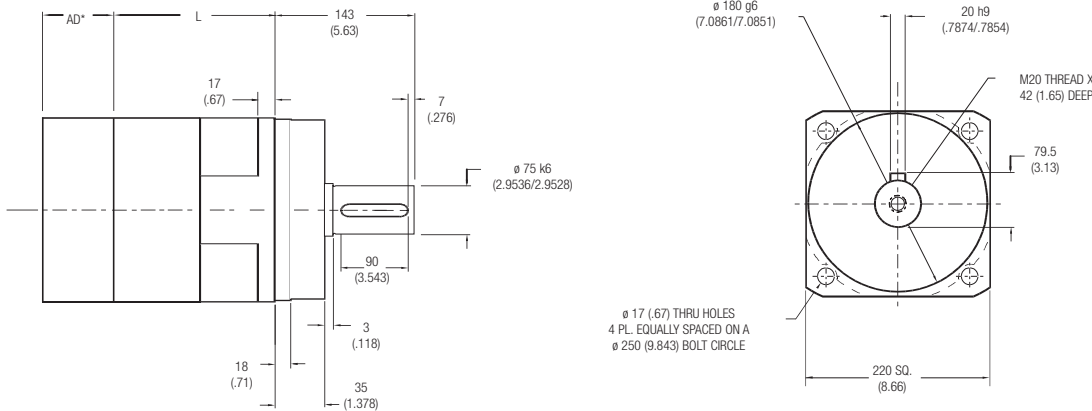

Ratio <sup>1</sup>	Dimension 'L' mm [in.]	Backlash [arc-min]	Weight kg [lb.]	Efficiency
4:1 to 10:1	142.7 [5.62]	4 max	74 [162]	93%
16:1 to 100:1	243.6 [9.60]	5 max	95 [209]	88%

All dimensions are: mm (in.)

AD\*\* = Adapter length

Adapter length will vary depending on motor.

M.S. = Mounting Surface

Efficiency is calculated at 100% of the rated torque.

## Performance Specifications

Part Number	Ratio <sup>1</sup>	10,000 Hour Life				T peak Nm [in.-lb.]	20,000 Hour Life			J kg-cm <sup>2</sup> [in.-lb.-sec <sup>2</sup> ×10 <sup>-4</sup> ]	Torsional Stiffness Nm/arc-min [in.- lb./arc-min]
		T <sub>r</sub> (1000 rpm) Nm [in.-lb.]	T <sub>r</sub> (3000 rpm) Nm [in.-lb.]	T <sub>r</sub> (5000 rpm) Nm [in.-lb.]	T <sub>r</sub> (1000 rpm) Nm [in.-lb.]		T <sub>r</sub> (3000 rpm) Nm [in.-lb.]	T <sub>r</sub> (5000 rpm) Nm [in.-lb.]			
UT022-004	4:1	2256 [19694]	1786 [15806]	1532 [13560]	4644 [41096]	2017 [17850]	1451 [12838]	1245 [11014]	87,0 [7.70]	429 [3793]	
UT022-005	5:1	2181 [19300]	1862 [16475]	1596 [14125]	4548 [40250]	2102 [18600]	1511 [13375]	1297 [11475]	73,4 [6.50]	414 [3661]	
UT022-007	7:1	2090 [18496]	1857 [16432]	1703 [15073]	4370 [38671]	2042 [18075]	1613 [14271]	1383 [12243]	62,6 [5.55]	363 [3212]	
UT022-010	10:1	1263 [11178]	1072 [9488]	987 [8737]	4301 [38060]	1167 [10325]	992 [8779]	914 [8085]	56,9 [5.04]	253 [2235]	
UT022-016	16:1	2521 [20292]	2293 [20292]	2170 [19202]	5247 [46437]	2464 [21805]	2199 [19459]	1886 [16694]	87,3 [7.73]	436 [3858]	
UT022-020	20:1	2561 [20732]	2343 [20732]	2224 [19683]	5323 [47107]	2504 [22164]	2291 [20273]	2017 [17850]	73,6 [6.52]	436 [3856]	
UT022-025	25:1	2484 [20205]	2283 [20205]	2174 [19239]	5151 [45583]	2427 [21480]	2232 [19757]	2102 [18605]	73,1 [6.47]	418 [3699]	
UT022-028	28:1	2620 [21365]	2414 [21365]	2302 [20375]	5427 [48027]	2560 [22660]	2361 [20892]	2231 [19476]	62,7 [5.55]	435 [3854]	
UT022-035	35:1	2541 [20788]	2349 [20788]	2246 [19878]	5243 [46397]	2481 [21961]	2297 [20327]	2196 [19438]	62,5 [5.53]	418 [3698]	
UT022-040	40:1	2680 [21998]	2486 [21998]	2381 [21069]	5524 [48888]	2619 [23182]	2431 [21510]	2328 [20602]	57,2 [5.06]	435 [3851]	
UT022-050	50:1	2595 [21371]	2415 [21371]	2318 [20516]	5328 [47156]	2536 [22443]	2361 [20898]	2267 [20062]	57,1 [5.05]	418 [3696]	
UT022-070	70:1	2461 [20373]	2302 [20373]	2217 [19623]	5025 [44470]	2405 [21288]	2251 [19922]	2168 [19189]	57,0 [5.04]	366 [3226]	
UT022-100	100:1	1666 [13121]	1483 [13121]	1387 [12273]	4852 [42941]	1571 [13902]	1369 [12116]	1283 [11356]	56,9 [5.04]	253 [2238]	

<sup>1</sup> Ratios are exact, higher ratios are also available, consult factory.  
T<sub>r</sub> = Rated output torque at rated speed for specific hours of life.

T<sub>peak</sub> = Allowable momentary peak torque for emergency stop or heavy shock loading.  
J = Mass moment of inertia reflected to the input shaft (including pinion assembly).

## Radial and Axial Load Ratings

### UT006

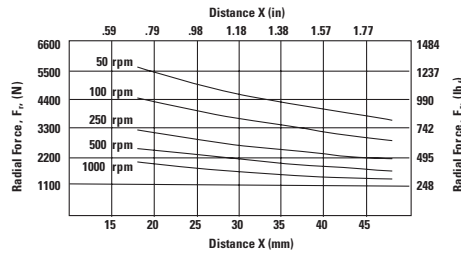
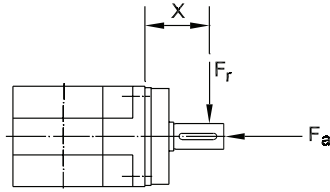

Speed rpm	Axial Load, $F_a$ N [lb.]
50	7198 [1618]
100	5710 [1284]
250	4208 [946]
500	3342 [751]
1000	2652 [596]

### UT075

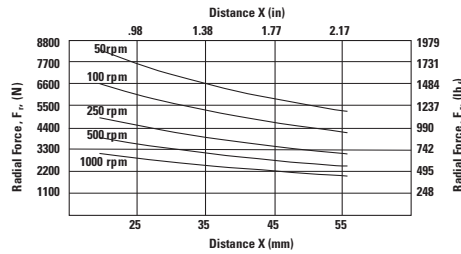
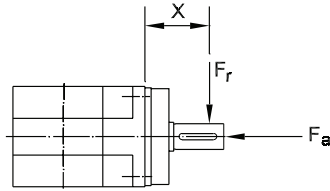

Speed rpm	Axial Load, $F_a$ N [lb.]
50	9903 [2227]
100	7863 [1768]
250	5793 [1303]
500	4599 [1034]
1000	3650 [821]

### UT090

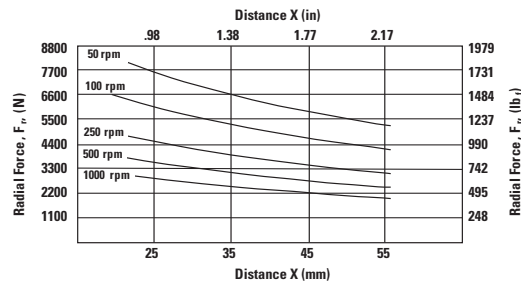
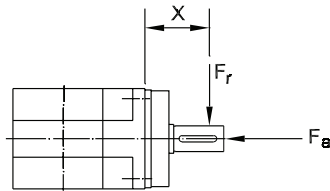

Speed rpm	Axial Load, $F_a$ N [lb.]
50	9903 [2227]
100	7863 [1768]
250	5793 [1303]
500	4599 [1034]
1000	3650 [821]

### UT010

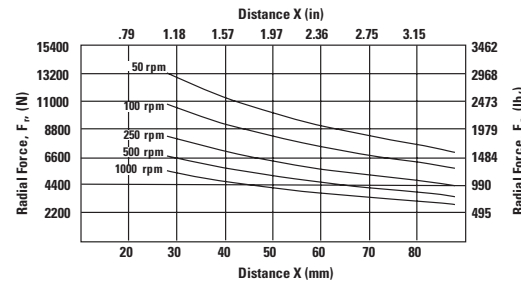
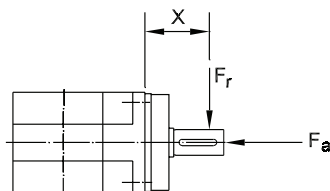

Speed rpm	Axial Load, $F_a$ N [lb.]
50	13,675 [3075]
100	11,107 [2497]
250	8435 [1897]
500	6855 [1542]
1000	5568 [1252]

These graphs display the allowable radial load at a given distance (X) from the mounting surface based on an  $L_{10}$  life of 10,000 hours for the mean output speed  $n_{mout}$ , as described on page 9.

# Micron TRUE Planetary® Gearheads

## Radial and Axial Load Ratings

### UT115

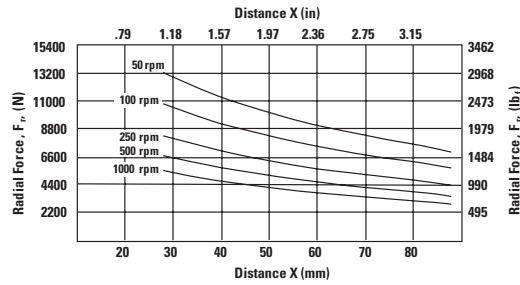
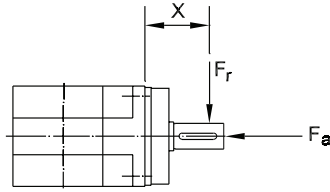

Speed rpm	Axial Load, $F_a$ N [lb.]
50	13,675 [3075]
100	11,107 [2497]
250	8435 [1897]
500	6855 [1542]
1000	5568 [1252]

### UT014

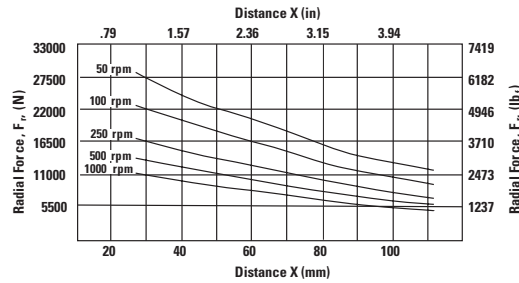
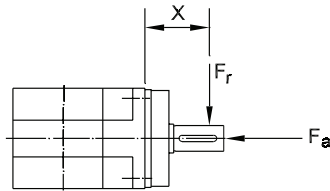

Speed rpm	Axial Load, $F_a$ N [lb.]
50	25,374 [5705]
100	20,609 [4633]
250	15,657 [3520]
500	12,716 [2859]
1000	10,329 [2322]

### UT018

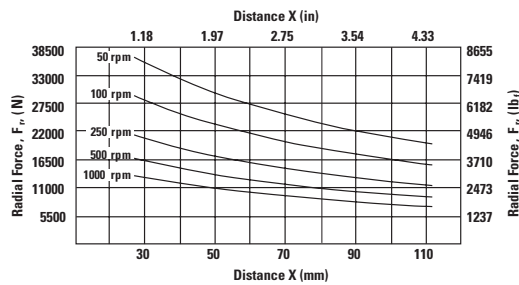
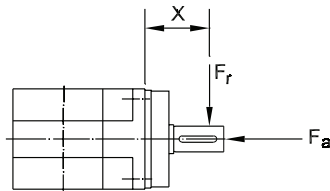

Speed rpm	Axial Load, $F_a$ N [lb.]
50	34,538 [7765]
100	27,414 [6163]
250	20,197 [4541]
500	16,034 [3605]
1000	12,726 [2861]

### UT022

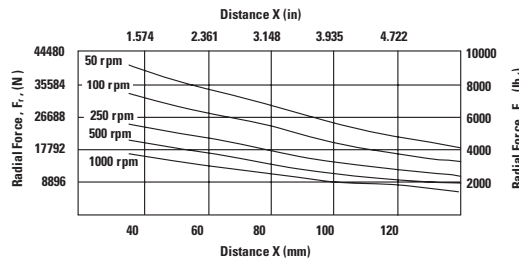
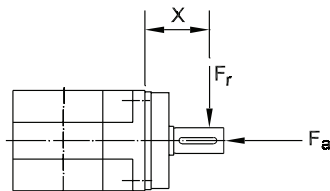

Speed rpm	Axial Load, $F_a$ N [lb.]
50	32,351 [3655]
100	26,277 [2969]
250	19,962 [2256]
500	16,214 [1832]

These graphs display the allowable radial load at a given distance (X) from the mounting surface based on an  $L_{10}$  life of 10,000 hours for the mean output speed  $n_{mout}$ , as described on page 9.

# Micron TRUE Planetary® Gearheads

## DuraTRUE 90 Size 142H (Hollow Shaft)

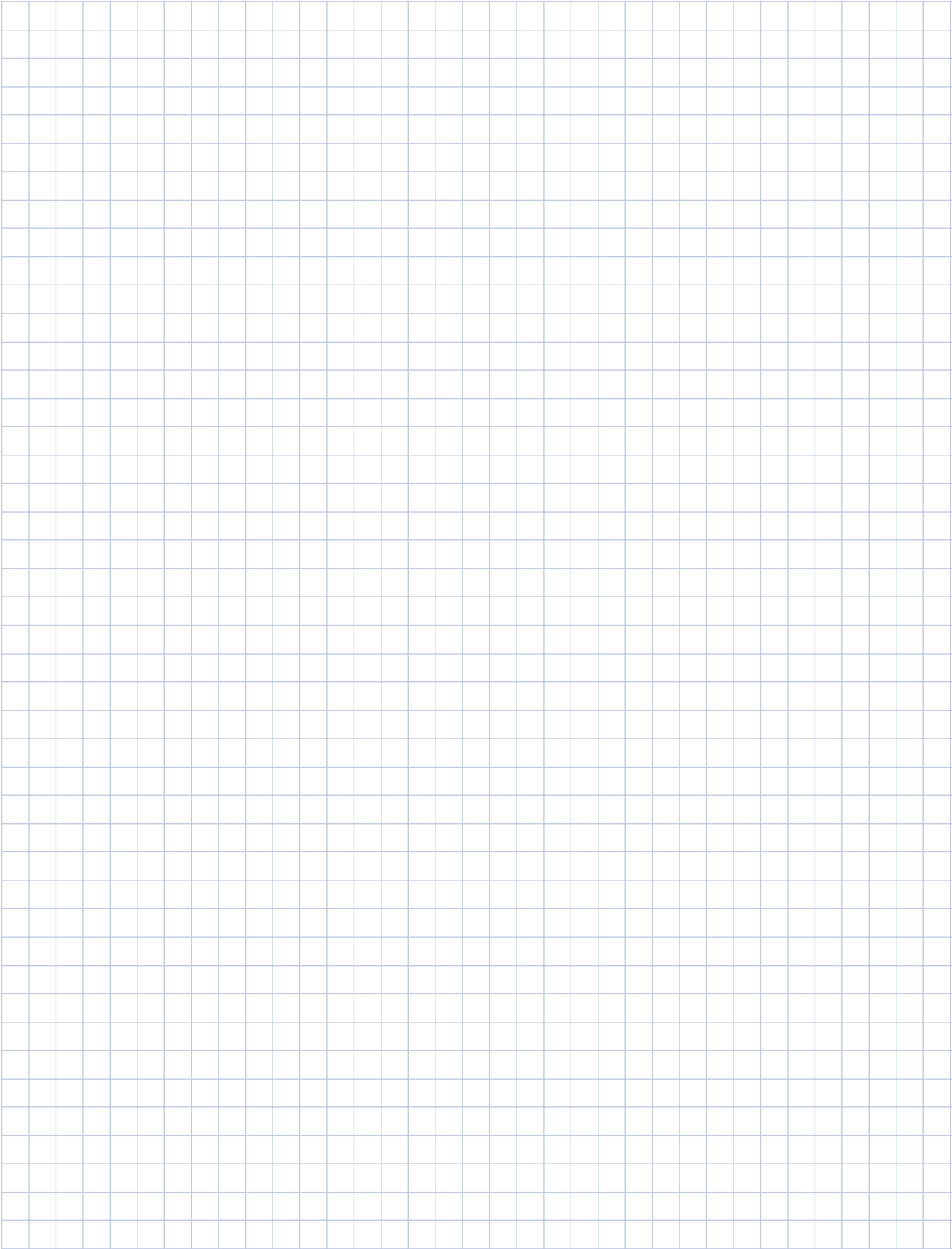

# Micron TRUE Planetary® Gearheads

## UltraTRUE™ 90

Helical Right Angle Gearheads

Ready for Immediate Delivery	
Precision	4 arc-minutes
Frame Sizes	60 mm, 75 mm, 90 mm, 100 mm, 115 mm, 142 mm and 180 mm
Torque Capacity	up to 3111 Nm
Ratio Availability	1:1 thru 50:1
Radial load capacity	up to 37910 N
Mounting System	RediMount™

- 1 Tapered roller bearings**  
provide high axial and radial load carrying capacity
- 2 Helical crowned**  
HRC 55-60 steel gears  
provide higher torque capacity and smoother operation
- 3 PowerTRUE™ gear technology**  
provides high torque capacity in a compact package
- 4 RediMount system**  
provides error-free motor installation

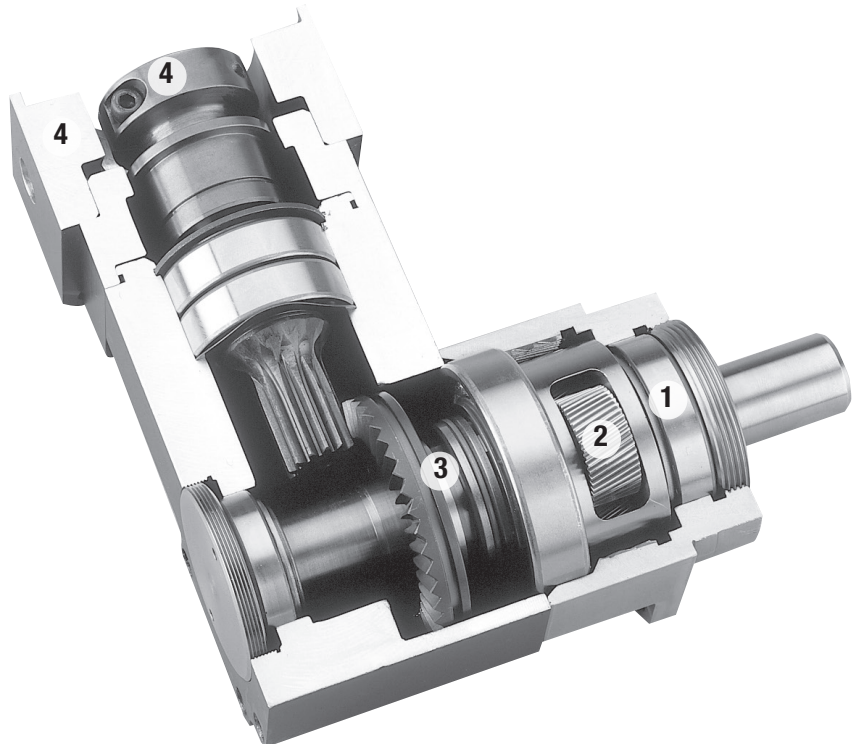

*Micron True Planetary® Gearheads  
shipped within 24 hours!*

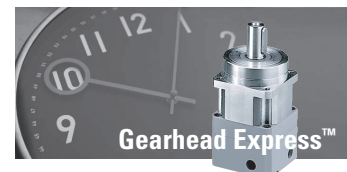

*Need it fast? Go to the back cover  
of the catalog for details.*

### Helical Right Angle Gearheads

Metric

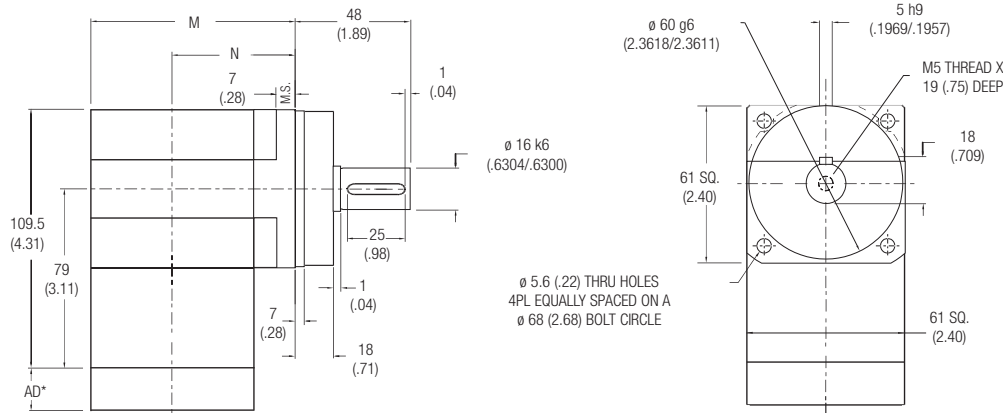

Ratio <sup>1</sup>	Dimension 'M' mm [in.]	Dimension 'N' mm [in.]	Backlash [arc-min]	Weight kg [lb.]	Efficiency
1:1 to 5:1	86 [3.38]	55 [2.18]	4 max	2,5 [5.5]	98%
8:1 to 50:1	95 [3.75]	65 [2.55]	5 max	3 [6.6]	93%

All dimensions are: mm (in.)

AD\*\* = Adapter length

Adapter length will vary depending on motor.

M.S.= Mounting Surface

Efficiency is calculated at 100% of the rated torque.

### Performance Specifications

Part Number	Ratio <sup>1</sup>	10,000 Hour Life			T <sub>peak</sub> Nm [in.-lb.]	20,000 Hour Life			J kg-cm <sup>2</sup> [in.-lb.-sec <sup>2</sup> x10 <sup>-4</sup> ]	Torsional Stiffness Nm/arc-min [in.-lb./arc-min]
		T <sub>r</sub> (1000 rpm) Nm [in.-lb.]	T <sub>r</sub> (3000 rpm) Nm [in.-lb.]	T <sub>r</sub> (5000 rpm) Nm [in.-lb.]		T <sub>r</sub> (1000 rpm) Nm [in.-lb.]	T <sub>r</sub> (3000 rpm) Nm [in.-lb.]	T <sub>r</sub> (5000 rpm) Nm [in.-lb.]		
UTR006-001	1:1	9 [77]	8 [70]	7 [64]	28 [247]	8 [71]	7 [65]	7 [59]	.97 [8.4]	2,1 [19]
UTR006-002	2:1	19 [170]	17 [155]	16 [140]	52 [456]	18 [157]	16 [143]	15 [129]	.50 [4.3]	3,2 [29]
UTR006-003	3:1	12 [108]	11 [99]	10 [89]	39 [342]	11 [100]	10 [91]	9 [82]	.43 [3.7]	3,6 [32]
UTR006-004	4:1	9 [80]	8 [73]	7 [66]	34 [301]	8 [73]	8 [67]	7 [61]	.40 [3.4]	3,8 [34]
UTR006-005	5:1	7 [65]	7 [60]	6 [54]	26 [228]	7 [60]	6 [55]	6 [50]	.39 [3.4]	3,9 [35]
UTR006-008	8:1	51 [447]	47 [413]	45 [394]	106 [938]	49 [438]	45 [397]	38 [340]	.50 [4.4]	2,1 [18]
UTR006-010	10:1	49 [433]	45 [401]	43 [384]	102 [906]	48 [423]	44 [392]	40 [355]	.49 [4.4]	1,8 [16]
UTR006-012	12:1	49 [432]	45 [394]	40 [356]	109 [961]	45 [399]	41 [364]	37 [329]	.39 [3.5]	2,0 [18]
UTR006-014	14:1	46 [411]	43 [383]	42 [368]	97 [860]	45 [402]	42 [374]	41 [360]	.49 [4.4]	2,4 [22]
UTR006-015	15:1	50 [443]	47 [413]	45 [397]	105 [927]	49 [433]	46 [404]	44 [388]	.39 [3.4]	2,4 [21]
UTR006-016	16:1	36 [318]	33 [290]	30 [262]	110 [975]	33 [294]	30 [268]	27 [242]	.39 [3.5]	2,4 [22]
UTR006-020	20:1	45 [398]	41 [363]	37 [328]	106 [939]	41 [367]	38 [335]	34 [303]	.39 [3.5]	2,4 [21]
UTR006-025	25:1	37 [326]	34 [298]	30 [269]	107 [948]	34 [301]	31 [275]	28 [249]	.38 [3.4]	2,3 [21]
UTR006-028	28:1	48 [427]	45 [401]	44 [388]	100 [887]	47 [417]	44 [392]	43 [379]	.39 [3.5]	2,2 [20]
UTR006-030	30:1	30 [266]	26 [232]	25 [217]	93 [822]	28 [246]	24 [215]	23 [201]	.42 [3.7]	2,3 [20]
UTR006-035	35:1	49 [432]	46 [407]	43 [377]	101 [894]	48 [422]	44 [385]	39 [348]	.38 [3.4]	2,3 [20]
UTR006-040	40:1	31 [275]	27 [240]	25 [225]	94 [830]	29 [255]	25 [223]	24 [208]	.39 [3.5]	2,4 [22]
UTR006-050	50:1	32 [283]	28 [247]	26 [232]	94 [836]	30 [262]	26 [229]	24 [215]	.38 [3.4]	2,4 [21]

All ratios are available to ship in 24 hours through the Gearhead Express Program.

<sup>1</sup> Ratios are exact, higher ratios are also available, consult factory.  
T<sub>r</sub> = Rated output torque at rated speed for specific hours of life.

T<sub>peak</sub> = Allowable momentary peak torque for emergency stop or heavy shock loading.  
J = Mass moment of inertia reflected to the input shaft (including pinion assembly).

# Micron TRUE Planetary® Gearheads

## UltraTRUE™ 90 Size 75

### Helical Right Angle Gearheads

Metric

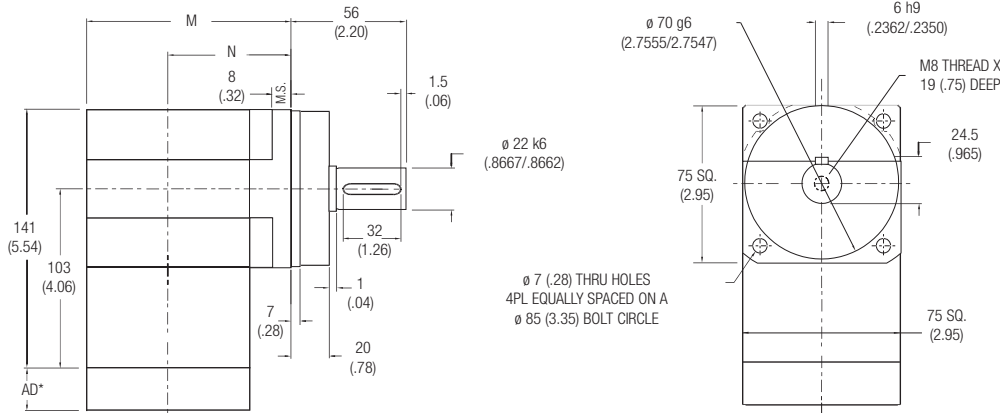

Ratio <sup>1</sup>	Dimension 'M' mm [in.]	Dimension 'N' mm [in.]	Backlash [arc-min]	Weight kg [lb.]	Efficiency
1:1 to 5:1	89 [3.51]	52 [2.04]	4 max	4.8 [10]	98%
8:1 to 50:1	114.5 [4.51]	77 [3.04]	5 max	5.3 [11.1]	93%

All dimensions are: mm (in.)  
 AD\*\* = Adapter length  
 Adapter length will vary depending on motor.  
 M.S. = Mounting Surface  
 Efficiency is calculated at 100% of the rated torque.

### Performance Specifications

Part Number	Ratio <sup>1</sup>	10,000 Hour Life				T peak Nm [in.-lb.]	20,000 Hour Life			J kg-cm <sup>2</sup> [in.-lb.-sec <sup>2</sup> x10 <sup>-4</sup> ]	Torsional Stiffness Nm/arc-min [in.-lb./arc-min]
		T <sub>r</sub> (1000 rpm) Nm [in.-lb.]	T <sub>r</sub> (3000 rpm) Nm [in.-lb.]	T <sub>r</sub> (5000 rpm) Nm [in.-lb.]	T <sub>r</sub> (1000 rpm) Nm [in.-lb.]		T <sub>r</sub> (3000 rpm) Nm [in.-lb.]	T <sub>r</sub> (5000 rpm) Nm [in.-lb.]			
UTR075-001	1:1	25 [220]	23 [200]	20 [181]	71 [625]	23 [203]	21 [185]	19 [167]	3,7 [33]	5,1 [46]	
UTR075-002	2:1	56 [498]	51 [455]	46 [411]	159 [1410]	52 [460]	47 [420]	43 [380]	1,9 [17]	7,7 [69]	
UTR075-003	3:1	37 [329]	34 [300]	31 [271]	129 [1146]	34 [304]	31 [277]	28 [250]	1,6 [15]	8,8 [78]	
UTR075-004	4:1	28 [252]	26 [230]	23 [208]	99 [880]	26 [232]	24 [212]	22 [192]	1,5 [13]	9,2 [81]	
UTR075-005	5:1	21 [185]	19 [169]	17 [153]	83 [735]	19 [171]	18 [156]	16 [141]	1,5 [13]	9,4 [83]	
UTR075-008	8:1	91 [802]	83 [737]	79 [702]	189 [1671]	89 [785]	81 [720]	78 [686]	1,9 [17]	4,7 [41]	
UTR075-010	10:1	88 [777]	81 [716]	77 [684]	183 [1617]	86 [759]	79 [700]	76 [669]	1,9 [17]	4,1 [36]	
UTR075-012	12:1	93 [824]	86 [762]	82 [730]	194 [1715]	91 [805]	84 [746]	81 [714]	1,5 [14]	4,6 [41]	
UTR075-014	14:1	83 [738]	77 [685]	74 [657]	174 [1536]	82 [722]	76 [670]	73 [643]	1,9 [17]	6,6 [58]	
UTR075-015	15:1	90 [796]	84 [740]	80 [710]	187 [1656]	88 [779]	82 [723]	78 [694]	1,5 [13]	6,7 [59]	
UTR075-016	16:1	95 [838]	88 [780]	85 [749]	197 [1743]	93 [820]	86 [762]	83 [732]	1,5 [14]	6,7 [59]	
UTR075-020	20:1	91 [810]	85 [756]	82 [727]	190 [1681]	89 [792]	83 [739]	80 [711]	1,5 [14]	6,5 [58]	
UTR075-025	25:1	93 [820]	87 [767]	84 [740]	192 [1698]	91 [801]	85 [750]	80 [705]	1,5 [13]	6,4 [57]	
UTR075-028	28:1	87 [768]	81 [720]	79 [695]	179 [1589]	85 [751]	80 [704]	77 [679]	1,5 [14]	5,9 [52]	
UTR075-030	30:1	54 [480]	47 [418]	44 [391]	166 [1473]	50 [444]	44 [387]	41 [361]	1,6 [15]	6,3 [56]	
UTR075-035	35:1	88 [776]	83 [730]	80 [706]	181 [1603]	86 [759]	81 [714]	78 [690]	1,5 [13]	6,3 [56]	
UTR075-040	40:1	56 [497]	49 [433]	46 [406]	168 [1489]	52 [460]	45 [401]	42 [375]	1,5 [14]	6,7 [59]	
UTR075-050	50:1	58 [510]	50 [446]	47 [418]	170 [1500]	53 [472]	47 [413]	44 [387]	1,5 [13]	6,6 [58]	

All ratios are available to ship in 24 hours through the Gearhead Express Program.

<sup>1</sup> Ratios are exact, higher ratios are also available, consult factory.  
 T<sub>r</sub> = Rated output torque at rated speed for specific hours of life.

T<sub>peak</sub> = Allowable momentary peak torque for emergency stop or heavy shock loading.  
 J = Mass moment of inertia reflected to the input shaft (including pinion assembly).



### Helical Right Angle Gearheads

Metric

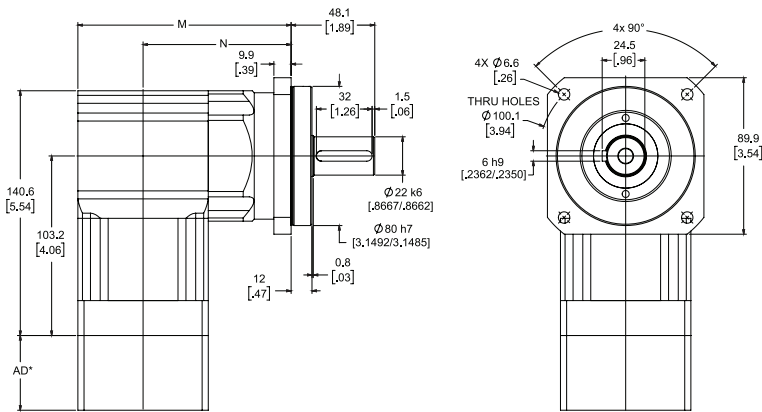

Ratio <sup>1</sup>	Dimension 'M' mm [in.]	Dimension 'N' mm [in.]	Backlash [arc-min]	Weight kg [lb.]	Efficiency
1:1 to 5:1	97 [3.82]	60 [2.35]	4 max	4.8 [10]	98%
8:1 to 50:1	122.5 [4.82]	85 [3.35]	5 max	5.3 [11.1]	93%

All dimensions are: mm (in.)

AD\*\* = Adapter length

Adapter length will vary depending on motor.M.S.= Mounting Surface

Efficiency is calculated at 100% of the rated torque.

### Performance Specifications

Part Number	Ratio <sup>1</sup>	10,000 Hour Life			T peak Nm [in.-lb.]	20,000 Hour Life			J kg-cm <sup>2</sup> [in.-lb.-sec <sup>2</sup> x10 <sup>-4</sup> ]	Torsional Stiffness Nm/arc-min [in.-lb./arc-min]
		T <sub>r</sub> (1000 rpm) Nm [in.-lb.]	T <sub>r</sub> (3000 rpm) Nm [in.-lb.]	T <sub>r</sub> (5000 rpm) Nm [in.-lb.]		T <sub>r</sub> (1000 rpm) Nm [in.-lb.]	T <sub>r</sub> (3000 rpm) Nm [in.-lb.]	T <sub>r</sub> (5000 rpm) Nm [in.-lb.]		
UTR090-001	1:1	25 [220]	23 [200]	20 [181]	71 [625]	23 [203]	21 [185]	19 [167]	3,7 [33]	5,1 [46]
UTR090-002	2:1	56 [498]	51 [455]	46 [411]	159 [1410]	52 [460]	47 [420]	43 [380]	1,9 [17]	7,7 [69]
UTR090-003	3:1	37 [329]	34 [300]	31 [271]	129 [1146]	34 [304]	31 [277]	28 [250]	1,6 [15]	8,8 [78]
UTR090-004	4:1	28 [252]	26 [230]	23 [208]	99 [880]	26 [232]	24 [212]	22 [192]	1,5 [13]	9,2 [81]
UTR090-005	5:1	21 [185]	19 [169]	17 [153]	83 [735]	19 [171]	18 [156]	16 [141]	1,5 [13]	9,4 [83]
UTR090-008	8:1	91 [802]	83 [737]	79 [702]	189 [1671]	89 [785]	81 [720]	78 [686]	1,9 [17]	4,7 [41]
UTR090-010	10:1	88 [777]	81 [716]	77 [684]	183 [1617]	86 [759]	79 [700]	76 [669]	1,9 [17]	4,1 [36]
UTR090-012	12:1	93 [824]	86 [762]	82 [730]	194 [1715]	91 [805]	84 [746]	81 [714]	1,5 [14]	4,6 [41]
UTR090-014	14:1	83 [738]	77 [685]	74 [657]	174 [1536]	82 [722]	76 [670]	73 [643]	1,9 [17]	6,6 [58]
UTR090-015	15:1	90 [796]	84 [740]	80 [710]	187 [1656]	88 [779]	82 [723]	78 [694]	1,5 [13]	6,7 [59]
UTR090-016	16:1	95 [838]	88 [780]	85 [749]	197 [1743]	93 [820]	86 [762]	83 [732]	1,5 [14]	6,7 [59]
UTR090-020	20:1	91 [810]	85 [756]	82 [727]	190 [1681]	89 [792]	83 [739]	80 [711]	1,5 [14]	6,5 [58]
UTR090-025	25:1	93 [820]	87 [767]	84 [740]	192 [1698]	91 [801]	85 [750]	80 [705]	1,5 [13]	6,4 [57]
UTR090-028	28:1	87 [768]	81 [720]	79 [695]	179 [1589]	85 [751]	80 [704]	77 [679]	1,5 [14]	5,9 [52]
UTR090-030	30:1	54 [480]	47 [418]	44 [391]	166 [1473]	50 [444]	44 [387]	41 [361]	1,6 [15]	6,3 [56]
UTR090-035	35:1	88 [776]	83 [730]	80 [706]	181 [1603]	86 [759]	81 [714]	78 [690]	1,5 [13]	6,3 [56]
UTR090-040	40:1	56 [497]	49 [433]	46 [406]	168 [1489]	52 [460]	45 [401]	42 [375]	1,5 [14]	6,7 [59]
UTR090-050	50:1	58 [510]	50 [446]	47 [418]	170 [1500]	53 [472]	47 [413]	44 [387]	1,5 [13]	6,6 [58]

All ratios are available to ship in 24 hours through the Gearhead Express Program.

<sup>1</sup> Ratios are exact, higher ratios are also available, consult factory.  
T<sub>r</sub> = Rated output torque at rated speed for specific hours of life.

T<sub>peak</sub> = Allowable momentary peak torque for emergency stop or heavy shock loading.  
J = Mass moment of inertia reflected to the input shaft (including pinion assembly).

# Micron TRUE Planetary® Gearheads

## UltraTRUE™ 90 Size 10

### Helical Right Angle Gearheads

Metric

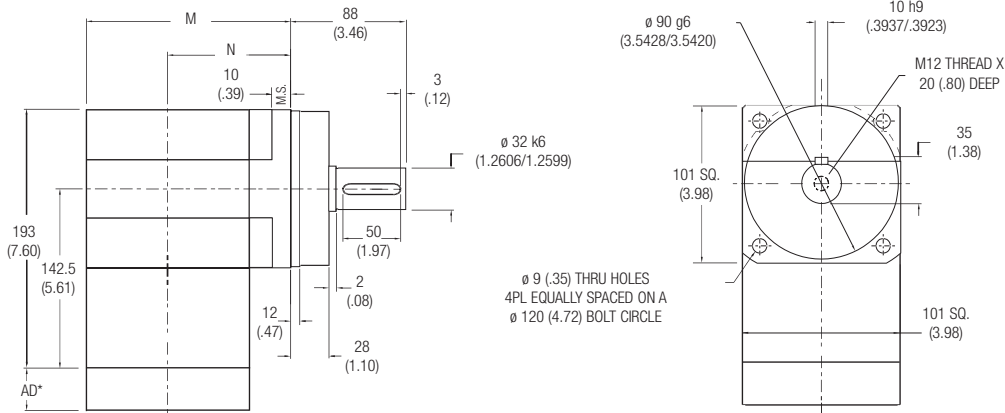

Ratio <sup>1</sup>	Dimension 'M' mm [in.]	Dimension 'N' mm [in.]	Backlash [arc-min]	Weight kg [lb.]	Efficiency
1:1 to 5:1	121 [4.75]	70 [2.76]	4 max	11 [24]	98%
8:1 to 50:1	149 [5.88]	99 [3.89]	5 max	12 [26.2]	93%

All dimensions are: mm (in.)  
 AD\*\* = Adapter length  
 Adapter length will vary depending on motor.  
 M.S. = Mounting Surface  
 Efficiency is calculated at 100% of the rated torque.

### Performance Specifications

Part Number	Ratio <sup>1</sup>	10,000 Hour Life				T peak Nm [in.-lb.]	20,000 Hour Life			J kg-cm <sup>2</sup> [in.-lb.-sec <sup>2</sup> x10 <sup>-4</sup> ]	Torsional Stiffness Nm/arc-min [in.-lb./arc-min]
		T <sub>r</sub> (1000 rpm) Nm [in.-lb.]	T <sub>r</sub> (3000 rpm) Nm [in.-lb.]	T <sub>r</sub> (5000 rpm) Nm [in.-lb.]	T <sub>r</sub> (1000 rpm) Nm [in.-lb.]		T <sub>r</sub> (3000 rpm) Nm [in.-lb.]	T <sub>r</sub> (5000 rpm) Nm [in.-lb.]			
UTR010-001	1:1	73 [648]	67 [591]	60 [535]	232 [2052]	68 [598]	62 [546]	56 [494]	6,3 [56]	9,2 [81]	
UTR010-002	2:1	131 [1157]	119 [1056]	108 [955]	323 [2856]	121 [1068]	110 [975]	100 [882]	3,2 [29]	15,0 [133]	
UTR010-003	3:1	101 [898]	93 [820]	84 [741]	292 [2582]	94 [830]	86 [757]	77 [684]	2,8 [25]	17,1 [151]	
UTR010-004	4:1	68 [598]	62 [546]	56 [494]	227 [2006]	62 [552]	57 [504]	51 [456]	2,6 [23]	17,9 [159]	
UTR010-005	5:1	51 [449]	46 [409]	42 [370]	187 [1653]	47 [414]	43 [378]	39 [342]	2,5 [23]	18,3 [162]	
UTR010-008	8:1	266 [2358]	243 [2147]	229 [2031]	547 [4844]	260 [2305]	217 [1923]	186 [1650]	3,3 [29]	16,6 [147]	
UTR010-010	10:1	258 [2286]	236 [2092]	225 [1989]	531 [4701]	253 [2235]	226 [2005]	194 [1720]	3,3 [29]	13,1 [116]	
UTR010-012	12:1	274 [2426]	252 [2229]	240 [2125]	564 [4992]	270 [2389]	245 [2171]	210 [1863]	2,6 [23]	18,8 [167]	
UTR010-014	14:1	246 [2178]	227 [2007]	217 [1917]	506 [4481]	241 [2129]	222 [1963]	207 [1834]	3,3 [29]	23,1 [204]	
UTR010-015	15:1	265 [2349]	245 [2168]	234 [2072]	546 [4832]	259 [2297]	240 [2120]	219 [1943]	2,5 [23]	24,3 [215]	
UTR010-016	16:1	270 [2393]	247 [2184]	223 [1975]	575 [5085]	250 [2210]	228 [2016]	206 [1823]	2,6 [23]	24,8 [220]	
UTR010-020	20:1	270 [2391]	251 [2219]	240 [2127]	555 [4916]	264 [2338]	245 [2170]	235 [2080]	2,6 [23]	22,1 [196]	
UTR010-025	25:1	253 [2243]	231 [2047]	209 [1851]	562 [4974]	234 [2072]	214 [1890]	193 [1709]	2,5 [23]	22,1 [196]	
UTR010-028	28:1	256 [2270]	239 [2119]	230 [2038]	526 [4659]	251 [2220]	234 [2072]	225 [1993]	2,6 [23]	19,2 [170]	
UTR010-030	30:1	159 [1405]	138 [1220]	129 [1139]	488 [4317]	147 [1300]	128 [1129]	119 [1054]	2,8 [25]	19,1 [169]	
UTR010-035	35:1	260 [2298]	243 [2152]	234 [2074]	532 [4707]	254 [2248]	238 [2104]	229 [2028]	2,5 [23]	19,0 [168]	
UTR010-040	40:1	164 [1456]	143 [1267]	134 [1184]	494 [4372]	152 [1347]	132 [1173]	124 [1096]	2,6 [23]	24,9 [221]	
UTR010-050	50:1	169 [1496]	147 [1304]	138 [1220]	498 [4410]	156 [1384]	136 [1207]	128 [1129]	2,5 [23]	21,9 [194]	

All ratios are available to ship in 24 hours through the Gearhead Express Program.

<sup>1</sup> Ratios are exact, higher ratios are also available, consult factory.  
 T<sub>r</sub> = Rated output torque at rated speed for specific hours of life.

T<sub>peak</sub> = Allowable momentary peak torque for emergency stop or heavy shock loading.  
 J = Mass moment of inertia reflected to the input shaft (including pinion assembly).

### Helical Right Angle Gearheads

Metric

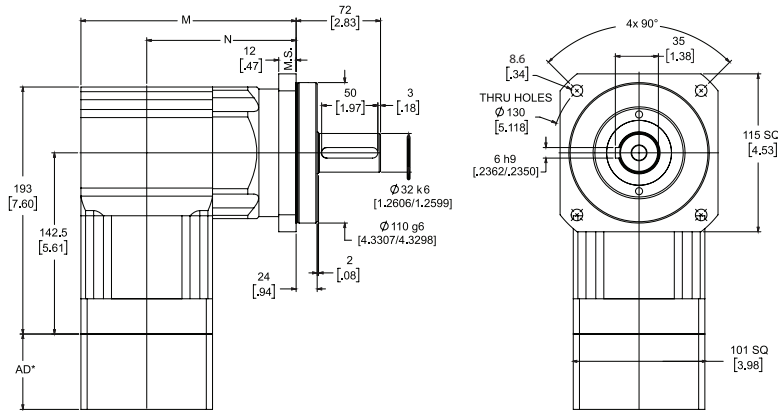

Ratio <sup>1</sup>	Dimension 'M' mm [in.]	Dimension 'N' mm [in.]	Backlash [arc-min]	Weight kg [lb.]	Efficiency
1:1 to 5:1	136,7 [5.38]	86 [3.39]	4 max	11 [24]	98%
8:1 to 50:1	165 [6.51]	114,8 [4.52]	5 max	12 [26.2]	93%

All dimensions are: mm (in.)

AD\*\* = Adapter length

Adapter length will vary depending on motor.

M.S. = Mounting Surface

Efficiency is calculated at 100% of the rated torque.

### Performance Specifications

Part Number	Ratio <sup>1</sup>	10,000 Hour Life			T peak Nm [in.-lb.]	20,000 Hour Life			J kg-cm <sup>2</sup> [in.-lb.-sec <sup>2</sup> x10 <sup>-4</sup> ]	Torsional Stiffness Nm/arc-min [in.-lb./arc-min]
		T <sub>r</sub> (1000 rpm) Nm [in.-lb.]	T <sub>r</sub> (3000 rpm) Nm [in.-lb.]	T <sub>r</sub> (5000 rpm) Nm [in.-lb.]		T <sub>r</sub> (1000 rpm) Nm [in.-lb.]	T <sub>r</sub> (3000 rpm) Nm [in.-lb.]	T <sub>r</sub> (5000 rpm) Nm [in.-lb.]		
UTR115-001	1:1	73 [648]	67 [591]	60 [535]	232 [2052]	68 [598]	62 [546]	56 [494]	6,3 [56]	9,2 [81]
UTR115-002	2:1	131 [1157]	119 [1056]	108 [955]	323 [2856]	121 [1068]	110 [975]	100 [882]	3,2 [29]	15,0 [133]
UTR115-003	3:1	101 [898]	93 [820]	84 [741]	292 [2582]	94 [830]	86 [757]	77 [684]	2,8 [25]	17,1 [151]
UTR115-004P	4:1	68 [598]	62 [546]	56 [494]	227 [2006]	62 [552]	57 [504]	51 [456]	2,6 [23]	17,9 [159]
UTR115-005P	5:1	51 [449]	46 [409]	42 [370]	187 [1653]	47 [414]	43 [378]	39 [342]	2,5 [23]	18,3 [162]
UTR115-008	8:1	266 [2358]	243 [2147]	229 [2031]	547 [4844]	260 [2305]	217 [1923]	186 [1650]	3,3 [29]	16,6 [147]
UTR115-010	10:1	258 [2286]	236 [2092]	225 [1989]	531 [4701]	253 [2235]	226 [2005]	194 [1720]	3,3 [29]	13,1 [116]
UTR115-012	12:1	274 [2426]	252 [2229]	240 [2125]	564 [4992]	270 [2389]	245 [2171]	210 [1863]	2,6 [23]	18,8 [167]
UTR115-014	14:1	246 [2178]	227 [2007]	217 [1917]	506 [4481]	241 [2129]	222 [1963]	207 [1834]	3,3 [29]	23,1 [204]
UTR115-015	15:1	265 [2349]	245 [2168]	234 [2072]	546 [4832]	259 [2297]	240 [2120]	219 [1943]	2,5 [23]	24,3 [215]
UTR115-016	16:1	270 [2393]	247 [2184]	223 [1975]	575 [5085]	250 [2210]	228 [2016]	206 [1823]	2,6 [23]	24,8 [220]
UTR115-020	20:1	270 [2391]	251 [2219]	240 [2127]	555 [4916]	264 [2338]	245 [2170]	235 [2080]	2,6 [23]	22,1 [196]
UTR115-025	25:1	253 [2243]	231 [2047]	209 [1851]	562 [4974]	234 [2072]	214 [1890]	193 [1709]	2,5 [23]	22,1 [196]
UTR115-028	28:1	256 [2270]	239 [2119]	230 [2038]	526 [4659]	251 [2220]	234 [2072]	225 [1993]	2,6 [23]	19,2 [170]
UTR115-030	30:1	159 [1405]	138 [1220]	129 [1139]	488 [4317]	147 [1300]	128 [1129]	119 [1054]	2,8 [25]	19,1 [169]
UTR115-035	35:1	260 [2298]	243 [2152]	234 [2074]	532 [4707]	254 [2248]	238 [2104]	229 [2028]	2,5 [23]	19,0 [168]
UTR115-040	40:1	164 [1456]	143 [1267]	134 [1184]	494 [4372]	152 [1347]	132 [1173]	124 [1096]	2,6 [23]	24,9 [221]
UTR115-050	50:1	169 [1496]	147 [1304]	138 [1220]	498 [4410]	156 [1384]	136 [1207]	128 [1129]	2,5 [23]	21,9 [194]

All ratios are available to ship in 24 hours through the Gearhead Express Program.

<sup>1</sup> Ratios are exact, higher ratios are also available, consult factory.  
T<sub>r</sub> = Rated output torque at rated speed for specific hours of life.

T<sub>peak</sub> = Allowable momentary peak torque for emergency stop or heavy shock loading.  
J = Mass moment of inertia reflected to the input shaft (including pinion assembly).

# Micron TRUE Planetary® Gearheads

## UltraTRUE™ 90 Size 14

### Helical Right Angle Gearheads

Metric

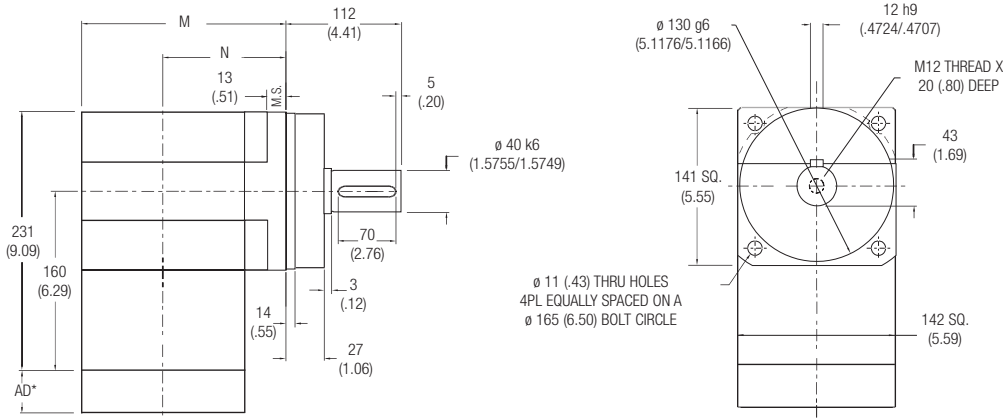

Ratio <sup>1</sup>	Dimension 'M' mm [in.]	Dimension 'N' mm [in.]	Backlash [arc-min]	Weight kg [lb.]	Efficiency
1:1 to 5:1P	166 [6.54]	95 [3.74]	4 max	24 [53]	98%
8:1 to 50:1	222 [8.74]	151 [5.95]	5 max	29 [64]	93%

All dimensions are: mm (in.)  
 AD\*\* = Adapter length  
 Adapter length will vary depending on motor.  
 M.S. = Mounting Surface  
 Efficiency is calculated at 100% of the rated torque.

### Performance Specifications

Part Number	Ratio <sup>1</sup>	10,000 Hour Life			T peak Nm [in.-lb.]	20,000 Hour Life			J kg-cm <sup>2</sup> [in.-lb.-sec <sup>2</sup> x10 <sup>-4</sup> ]	Torsional Stiffness Nm/arc-min [in.-lb./arc-min]
		T <sub>r</sub> (1000 rpm) Nm [in.-lb.]	T <sub>r</sub> (3000 rpm) Nm [in.-lb.]	T <sub>r</sub> (5000 rpm) Nm [in.-lb.]		T <sub>r</sub> (1000 rpm) Nm [in.-lb.]	T <sub>r</sub> (3000 rpm) Nm [in.-lb.]	T <sub>r</sub> (5000 rpm) Nm [in.-lb.]		
UTR014-001	1:1	158 [1396]	144 [1274]	130 [1152]	380 [3363]	146 [1289]	133 [1177]	120 [1064]	32 [279]	28,4 [252]
UTR014-002	2:1	327 [2893]	298 [2640]	270 [2387]	708 [6270]	302 [2671]	275 [2438]	249 [2204]	16 [143]	46,6 [413]
UTR014-003	3:1	220 [1944]	201 [1774]	181 [1604]	545 [4822]	203 [1796]	185 [1639]	167 [1481]	14 [123]	52,9 [468]
UTR014-004P	4:1	158 [1396]	144 [1274]	130 [1152]	471 [4172]	146 [1289]	133 [1177]	120 [1064]	13 [114]	55,5 [491]
UTR014-005P	5:1	118 [1047]	108 [956]	98 [864]	396 [3506]	109 [967]	100 [883]	90 [798]	13 [112]	56,8 [503]
UTR014-008	8:1	625 [5531]	565 [5000]	533 [4719]	1269 [11,233]	611 [5408]	530 [4688]	454 [4022]	16 [146]	36,7 [325]
UTR014-010	10:1	606 [5364]	551 [4876]	522 [4617]	1233 [10,911]	593 [5245]	539 [4768]	474 [4192]	16 [145]	31,9 [282]
UTR014-012	12:1	644 [5702]	588 [5207]	559 [4944]	1313 [11,616]	630 [5576]	575 [5092]	513 [4542]	13 [116]	22,1 [195]
UTR014-014	14:1	578 [5118]	530 [4690]	504 [4461]	1179 [10,430]	565 [5005]	518 [4586]	493 [4363]	16 [145]	51,6 [457]
UTR014-015	15:1	624 [5522]	572 [5067]	545 [4824]	1272 [11,253]	610 [5399]	560 [4955]	533 [4717]	12 [113]	51,7 [457]
UTR014-016	16:1	631 [5587]	576 [5099]	521 [4610]	1340 [11,860]	583 [5160]	532 [4708]	481 [4257]	13 [115]	52,8 [467]
UTR014-020	20:1	636 [5627]	587 [5194]	561 [4963]	1296 [11,471]	622 [5503]	574 [5079]	548 [4854]	13 [115]	49,2 [435]
UTR014-025	25:1	592 [5240]	540 [4782]	488 [4324]	1314 [11,625]	547 [4839]	499 [4415]	451 [3992]	12 [113]	49,2 [435]
UTR014-028	28:1	605 [5350]	561 [4969]	539 [4767]	1231 [10,896]	591 [5232]	549 [4859]	527 [4661]	13 [115]	42,8 [379]
UTR014-030	30:1	380 [3363]	329 [2914]	307 [2715]	1143 [10,111]	352 [3112]	305 [2696]	284 [2512]	14 [124]	44,7 [396]
UTR014-035	35:1	612 [5420]	571 [5052]	549 [4857]	1246 [11,024]	599 [5300]	558 [4941]	537 [4750]	12 [113]	40,2 [356]
UTR014-040	40:1	394 [3486]	342 [3028]	319 [2826]	1159 [10,257]	364 [3226]	317 [2802]	295 [2615]	13 [115]	52,6 [466]
UTR014-050	50:1	405 [3584]	352 [3118]	329 [2914]	1171 [10,360]	375 [3316]	326 [2886]	305 [2696]	12 [112]	49,2 [435]

All ratios are available to ship in 24 hours through the Gearhead Express Program.

<sup>1</sup> Ratios are exact, higher ratios are also available, consult factory.  
 T<sub>r</sub> = Rated output torque at rated speed for specific hours of life.

T<sub>peak</sub> = Allowable momentary peak torque for emergency stop or heavy shock loading.  
 J = Mass moment of inertia reflected to the input shaft (including pinion assembly).

### Helical Right Angle Gearheads

Metric

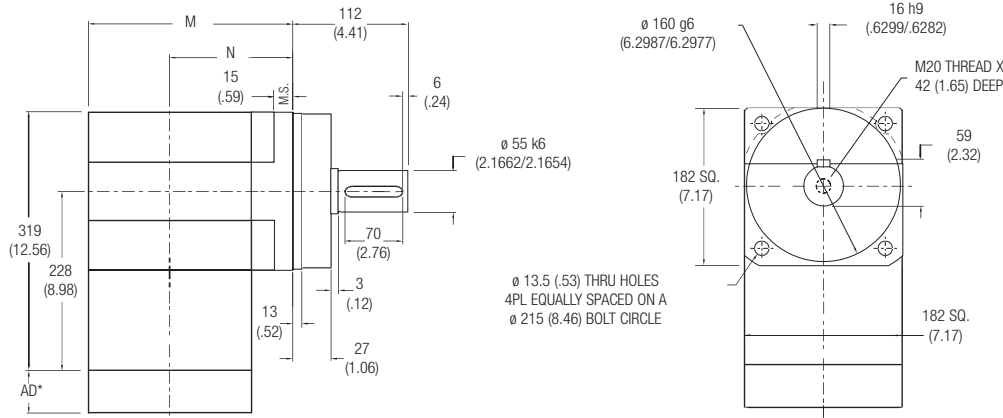

Ratio <sup>1</sup>	Dimension 'M' mm [in.]	Dimension 'N' mm [in.]	Backlash [arc-min]	Weight kg [lb.]	Efficiency
1:1 to 5:1	219 [8.64]	128 [5.05]	4 max	43 [96]	98%
8:1 to 50:1	273 [10.76]	182 [7.18]	5 max	48 [106]	93%

All dimensions are: mm (in.)  
 AD\*\* = Adapter length  
 Adapter length will vary depending on motor.  
 M.S. = Mounting Surface  
 Efficiency is calculated at 100% of the rated torque.

### Performance Specifications

Part Number	Ratio <sup>1</sup>	10,000 Hour Life			T peak Nm [in.-lb.]	20,000 Hour Life			J kg-cm <sup>2</sup> [in.-lb.-sec <sup>2</sup> x10 <sup>-4</sup> ]	Torsional Stiffness Nm/arc-min [in.-lb./arc-min]
		T <sub>r</sub> (1000 rpm) Nm [in.-lb.]	T <sub>r</sub> (3000 rpm) Nm [in.-lb.]	T <sub>r</sub> (5000 rpm) Nm [in.-lb.]		T <sub>r</sub> (1000 rpm) Nm [in.-lb.]	T <sub>r</sub> (3000 rpm) Nm [in.-lb.]	T <sub>r</sub> (5000 rpm) Nm [in.-lb.]		
UTR018-001	1:1	248 [2195]	226 [2003]	205 [1811]	819 [7246]	229 [2027]	209 [1850]	189 [1672]	111 [985]	50 [440]
UTR018-002	2:1	654 [5786]	597 [5280]	539 [4774]	1911 [16914]	604 [5343]	551 [4876]	498 [4408]	57 [505]	82 [722]
UTR018-003	3:1	507 [4489]	463 [4096]	419 [3704]	1674 [14817]	468 [4145]	427 [3783]	386 [3420]	49 [434]	93 [820]
UTR018-004P	4:1	361 [3192]	329 [2913]	298 [2633]	1190 [10536]	333 [2947]	304 [2690]	275 [2432]	46 [403]	97 [860]
UTR018-005P	5:1	254 [2245]	231 [2048]	209 [1852]	837 [7410]	234 [2073]	214 [1892]	193 [1710]	45 [396]	99 [880]
UTR018-008	8:1	1460 [12920]	1309 [11589]	1230 [10888]	2929 [25920]	1428 [12634]	1184 [10476]	1016 [8988]	45 [401]	113 [998]
UTR018-010	10:1	1418 [12547]	1279 [11322]	1206 [10673]	2851 [25228]	1386 [12269]	1234 [10918]	1058 [9366]	45 [398]	92 [812]
UTR018-012	12:1	1509 [13352]	1368 [12108]	1294 [11448]	3040 [26900]	1475 [13057]	1337 [11832]	1147 [10150]	36 [317]	63 [560]
UTR018-014	14:1	1355 [11993]	1234 [10917]	1169 [10344]	2733 [24185]	1325 [11728]	1206 [10675]	1129 [9989]	45 [398]	111 [986]
UTR018-015	15:1	1463 [12944]	1333 [11800]	1265 [11192]	2950 [26109]	1430 [12657]	1304 [11539]	1195 [10578]	35 [310]	144 [1272]
UTR018-016	16:1	1443 [12769]	1317 [11652]	1191 [10536]	3111 [27532]	1332 [11791]	1216 [10760]	1099 [9729]	36 [316]	147 [1299]
UTR018-020	20:1	1493 [13209]	1370 [12121]	1304 [11541]	3014 [26674]	1460 [12917]	1339 [11853]	1275 [11285]	36 [316]	142 [1257]
UTR018-025	25:1	1268 [11226]	1158 [10245]	1047 [9263]	3060 [27078]	1171 [10366]	1069 [9460]	967 [8554]	35 [309]	119 [1055]
UTR018-028	28:1	1421 [12576]	1313 [11620]	1255 [11110]	2870 [25400]	1390 [12298]	1284 [11362]	1228 [10864]	36 [316]	126 [1113]
UTR018-030	30:1	897 [7935]	775 [6856]	721 [6377]	2665 [23583]	830 [7342]	717 [6344]	667 [5900]	38 [339]	113 [997]
UTR018-035	35:1	1441 [12750]	1337 [11828]	1281 [11338]	2908 [25736]	1409 [12468]	1307 [11567]	1253 [11087]	35 [309]	113 [998]
UTR018-040	40:1	930 [8231]	806 [7131]	751 [6645]	2708 [23967]	861 [7616]	746 [6599]	695 [6149]	36 [314]	147 [1299]
UTR018-050	50:1	956 [8465]	830 [7348]	775 [6856]	2739 [24239]	885 [7832]	768 [6799]	717 [6344]	35 [308]	142 [1257]

<sup>1</sup> Ratios are exact, higher ratios are also available, consult factory.  
 T<sub>r</sub> = Rated output torque at rated speed for specific hours of life.

T<sub>peak</sub> = Allowable momentary peak torque for emergency stop or heavy shock loading.  
 J = Mass moment of inertia reflected to the input shaft (including pinion assembly).

# Micron TRUE Planetary® Gearheads

## Radial and Axial Load Ratings

Ratios 1:1 thru 5:1 only

UTR006

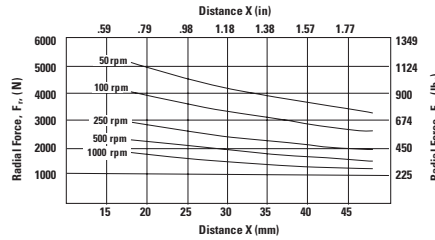
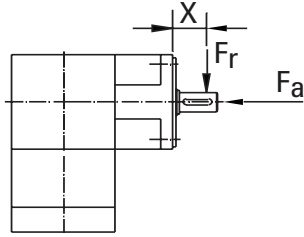

Speed rpm	Axial Load, $F_a$ N [lb <sub>f</sub> ]
50	6543 [1471]
100	5191 [1167]
250	3825 [860]
500	3038 [683]
1000	2411 [542]

UTR075 and UTR090

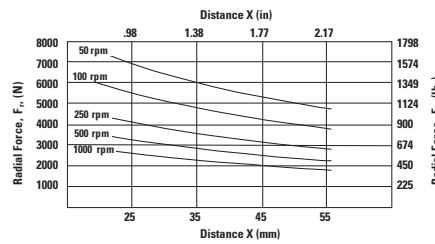
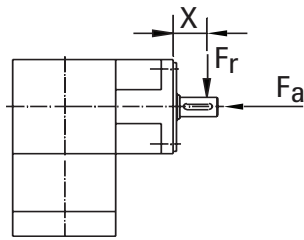

Speed rpm	Axial Load, $F_a$ N [lb <sub>f</sub> ]
50	9003 [2024]
100	7148 [1607]
250	5266 [1184]
500	4181 [940]
1000	3318 [746]

UTR010 and UTR115

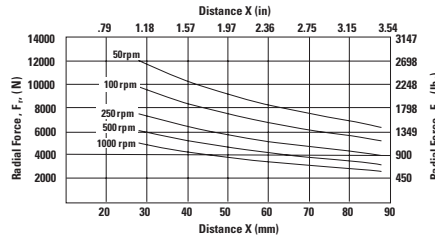
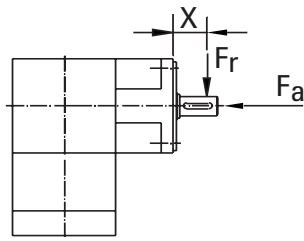

Speed rpm	Axial Load, $F_a$ N [lb <sub>f</sub> ]
50	12,432 [2795]
100	10,097 [2270]
250	7668 [1724]
500	6232 [1401]
1000	5062 [1138]

UTR014

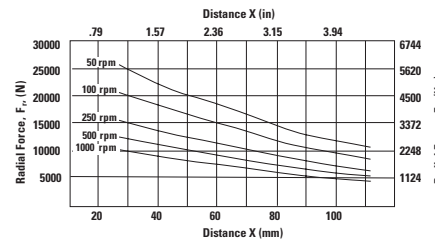
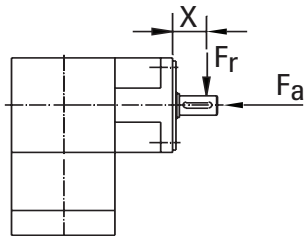

Speed rpm	Axial Load, $F_a$ N [lb <sub>f</sub> ]
50	23,067 [5186]
100	18,735 [4212]
250	14,234 [3200]
500	11,560 [2599]
1000	9390 [2111]

UTR018

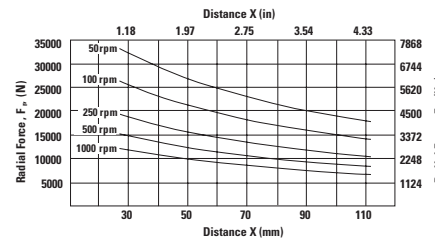
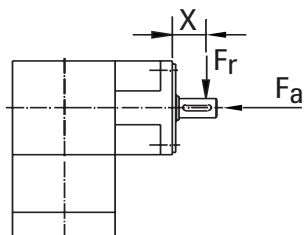

Speed rpm	Axial Load, $F_a$ N [lb <sub>f</sub> ]
50	31,398 [7059]
100	24,922 [5603]
250	18,361 [4128]
500	14,576 [3277]
1000	11,569 [2601]

These graphs display the allowable radial load at a given distance (X) from the mounting surface based on an L<sub>10</sub> life of 10,000 hours for the mean output speed  $n_{mout}$ , as described on page 9.

## Radial and Axial Load Ratings

### Ratios 8:1 thru 50:1 only

#### UTR006

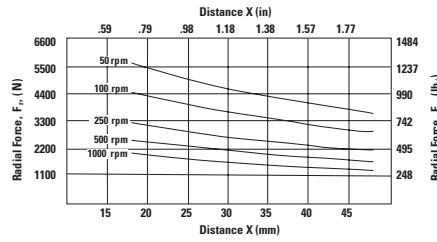
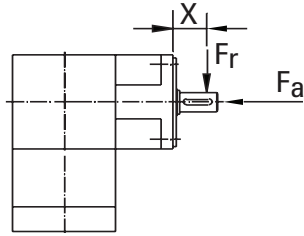

Speed rpm	Axial Load, $F_a$ N [lb <sub>f</sub> ]
50	7198 [1618]
100	5710 [1284]
250	4208 [946]
500	3342 [751]
1000	2652 [596]

#### UTR075 and UTR090

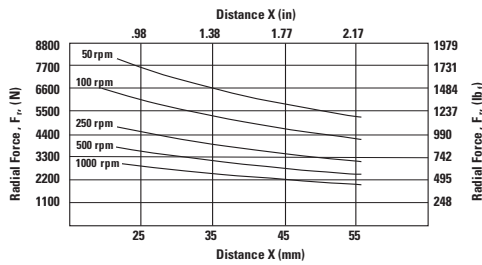
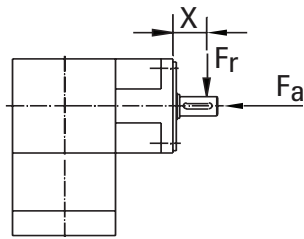

Speed rpm	Axial Load, $F_a$ N [lb <sub>f</sub> ]
50	9903 [2227]
100	7863 [1768]
250	5793 [1303]
500	4599 [1034]
1000	3650 [821]

#### UTR010 and UTR115

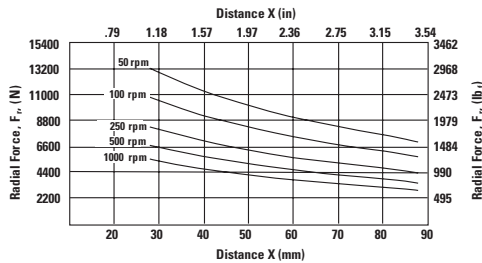
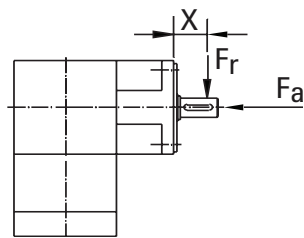

Speed rpm	Axial Load, $F_a$ N [lb <sub>f</sub> ]
50	13,675 [3075]
100	11,107 [2497]
250	8435 [1897]
500	6855 [1542]
1000	5568 [1252]

#### UTR014

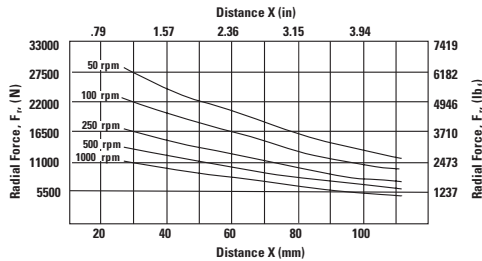
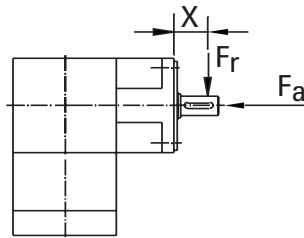

Speed rpm	Axial Load, $F_a$ N [lb <sub>f</sub> ]
50	25,374 [5705]
100	20,609 [4633]
250	15,657 [3520]
500	12,716 [2859]
1000	10,329 [2322]

#### UTR018

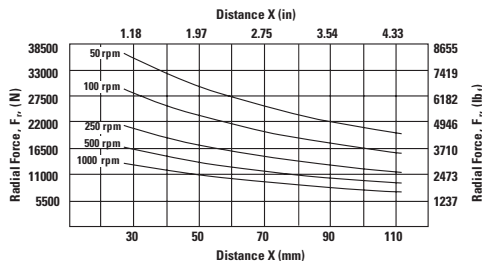
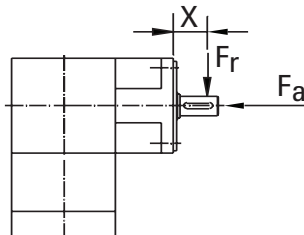

Speed rpm	Axial Load, $F_a$ N [lb <sub>f</sub> ]
50	34,538 [7765]
100	27,414 [6163]
250	20,197 [4541]
500	16,034 [3605]
1000	12,726 [2861]

These graphs display the allowable radial load at a given distance (X) from the mounting surface based on an  $L_{10}$  life of 10,000 hours for the mean output speed  $n_{\text{mount}}$ , as described on page 9.

# Micron TRUE Planetary® Gearheads

## EverTRUE™ Continuous Duty

### True Planetary Gearheads

Ready for Immediate Delivery	
Precision	4 arc-minutes
Frame Sizes	100 mm, 140 mm and 180 mm
Torque Capacity	up to 1017 Nm
Ratio Availability	4:1 thru 100:1
Radial load capacity	up to 44600 N
Mounting System	RediMount™

- 1 **Single-piece output shaft with**  
straddle mount bearing for  
increased stiffness
- 2 **High-capacity, tapered roller bearings**
- 3 **Double full complement needle**  
bearings for continuous operation
- 4 **Gears lubricated with**  
continuous duty grease
- 5 **True Planetary Gearing**  
optimized for continuous duty
- 6 **Single-piece output**  
housing with integral internal gear
- 7 **Angular contact bearing**
- 8 **Input bearing with thermal**  
compensation feature
- 9 **RediMount system**  
provides error-free installation

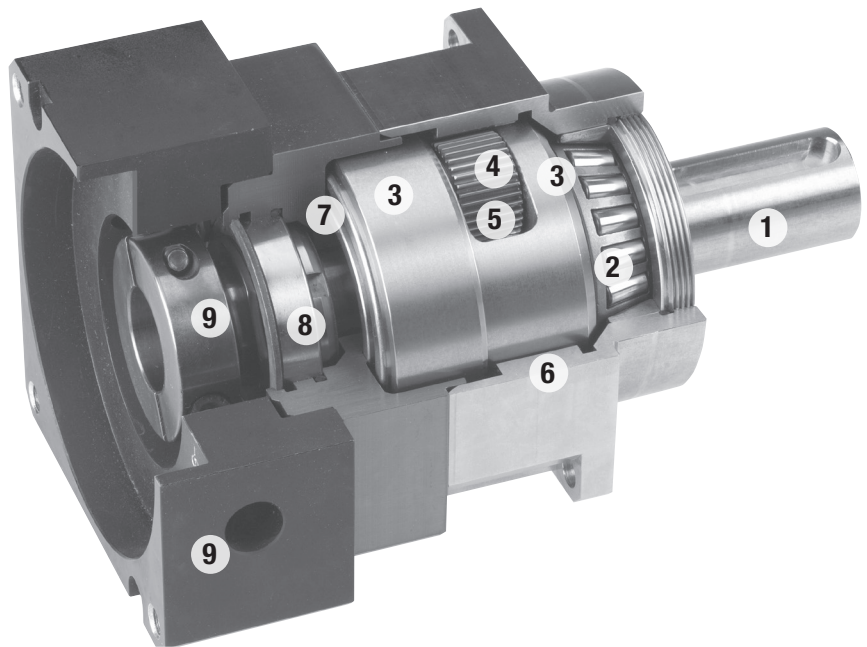

**Stainless steel output housing**



### True Planetary Gearheads

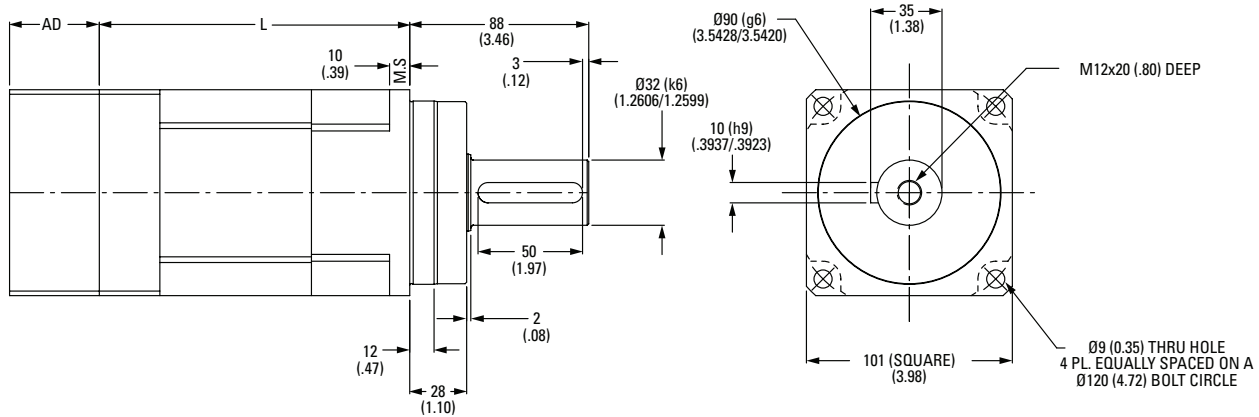

Ratio <sup>1</sup>	Stages	Dimension 'L' mm [in.]	Backlash [arc-min]	Weight kg [lb.]	Efficiency
4:1 to 10:1	1	78 [3.07]	4 max	6 [13]	95%
16:1 to 100:1	2	146 [5.75]	5 max	8 [18]	90%

All dimensions are in mm (in.)  
 AD\*\* = Adapter length  
 Adapter length will vary depending on motor.  
 Efficiency is calculated at 100% of the rated torque.

### Performance Specifications

Part Number	Ratio <sup>1</sup>	Intermittent (Trc) Nm [in.-lb.]	30000 Hour Life			T <sub>peak</sub> Nm [in.-lb.]	J kg-cm <sup>2</sup> [in.-lb.-sec <sup>2</sup> ×10 <sup>-4</sup> ]	Torsional Stiffness Nm/arc-min [in.-lb./arc-min]
			T <sub>r</sub> (1000 rpm) Nm [in.-lb.]	T <sub>r</sub> (3000 rpm) Nm [in.-lb.]	T <sub>r</sub> (5000 rpm) Nm [in.-lb.]			
ET010-004	4:1	171 [1514]	147 [1303]	106 [937]	91 [804]	463 [4093]	1,50 [13.3]	28,27 [250]
ET010-005	5:1	178 [1579]	144 [1272]	110 [977]	95 [838]	451 [3991]	1,29 [11.5]	25,08 [222]
ET010-007	7:1	190 [1684]	137 [1217]	118 [1042]	101 [893]	433 [3830]	0,92 [8.1]	23,21 [205]
ET010-010	10:1	106 [940]	77 [677]	66 [581]	61 [539]	411 [3640]	0,86 [7.6]	15,84 [140]
ET010-016	16:1	245 [2166]	164 [1450]	151 [1340]	138 [1218]	517 [4577]	1,05 [9.2]	30,03 [267]
ET010-020	20:1	249 [2205]	166 [1470]	154 [1364]	147 [1303]	524 [4637]	1,05 [9.2]	26,73 [237]
ET010-025	25:1	242 [2140]	161 [1421]	150 [1324]	14 [127]	506 [4477]	1,05 [9.2]	26,73 [237]
ET010-028	28:1	255 [2261]	169 [1499]	158 [1399]	152 [1345]	533 [4718]	0,89 [7.9]	23,21 [205]
ET010-035	35:1	248 [2191]	164 [1448]	153 [1355]	148 [1306]	514 [4549]	0,75 [6.7]	22,99 [204]
ET010-040	40:1	262 [2316]	173 [1528]	162 [1433]	156 [1383]	542 [4794]	0,75 [6.7]	30,14 [267]
ET010-050	50:1	253 [2243]	167 [1475]	157 [1387]	152 [1341]	521 [4615]	0,74 [6.6]	26,51 [235]
ET010-070	70:1	241 [2131]	158 [1396]	149 [1318]	144 [1277]	491 [4349]	0,74 [6.6]	23,21 [205]
ET010-100	100:1	144 [1277]	102 [902]	89 [790]	84 [741]	459 [4059]	0,74 [6.6]	18,92 [168]

<sup>1</sup> Ratios are exact, higher ratios are also available, consult factory.  
 T<sub>r</sub> = Rated output torque at rated speed for specific hours of life.  
 T<sub>rc</sub> = Rated output torque for intermittent operation at 3,000 RPM  
 (20,000 hr life - for catalog comparison)

T<sub>peak</sub> = Allowable momentary peak torque for emergency stop or heavy shock loading.  
 J = Mass moment of inertia reflected to the input shaft (including pinion assembly).

# Micron TRUE Planetary® Gearheads

## EverTRUE™ Size 14 Continuous Duty

### True Planetary Gearheads

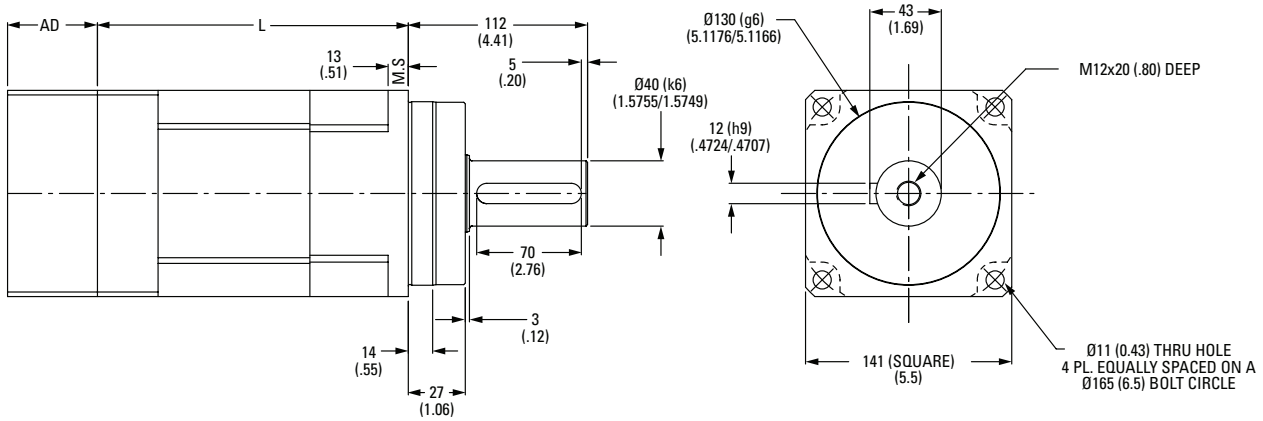

Ratio <sup>1</sup>	Stages	Dimension 'L' mm [in.]	Backlash [arc-min]	Weight kg [lb.]	Efficiency
4:1 to 10:1	1	110,5 [4.35]	4 max	14 [31]	95%
16:1 to 100:1	2	195 [7.69]	5 max	18 [40]	90%

All dimensions are in mm (in.)

AD\*\* = Adapter length

Adapter length will vary depending on motor.

Efficiency is calculated at 100% of the rated torque.

## Performance Specifications

Part Number	Ratio <sup>1</sup>	Intermittent (Trc) Nm [in.-lb.]	30000 Hour Life			T <sub>peak</sub> Nm [in.-lb.]	J kg-cm <sup>2</sup> [in.-lb.-sec <sup>2</sup> x10 <sup>-9</sup> ]	Torsional Stiffness Nm/arc-min [in.-lb./arc-min]
			T <sub>r</sub> (1000 rpm) Nm [in.-lb.]	T <sub>r</sub> (3000 rpm) Nm [in.-lb.]	T <sub>r</sub> (5000 rpm) Nm [in.-lb.]			
ET014-004	4:1	417 [3694]	345 [3055]	258 [2285]	221 [1960]	1066 [9431]	6,18 [55]	60,50 [536]
ET014-005	5:1	435 [3849]	336 [2972]	269 [2381]	231 [2042]	1040 [9206]	4,77 [42]	56,10 [497]
ET014-007	7:1	464 [4105]	322 [2849]	287 [2539]	246 [2179]	1002 [8866]	3,61 [32]	51,70 [458]
ET014-010	10:1	253 [2237]	183 [1618]	156 [1384]	145 [1279]	956 [8459]	3,22 [29]	38,50 [341]
ET014-016	16:1	573 [5070]	386 [3413]	354 [3136]	336 [2971]	1206 [10674]	4,00 [35]	63,80 [565]
ET014-020	20:1	584 [5168]	391 [3463]	361 [3197]	345 [3055]	1224 [10832]	3,87 [34]	59,40 [526]
ET014-025	25:1	567 [5016]	378 [3347]	351 [3103]	336 [2972]	1182 [10463]	3,87 [34]	59,40 [526]
ET014-028	28:1	600 [5309]	399 [3535]	371 [3284]	356 [3150]	1248 [11047]	3,35 [30]	51,70 [458]
ET014-035	35:1	581 [5145]	386 [3415]	360 [3182]	346 [3059]	1204 [10653]	2,84 [25]	48,40 [428]
ET014-040	40:1	616 [5448]	408 [3608]	381 [3370]	367 [3245]	1271 [11248]	2,84 [25]	63,80 [565]
ET014-050	50:1	596 [5274]	393 [3482]	369 [3262]	356 [3146]	1224 [10831]	2,71 [24]	59,40 [526]
ET014-070	70:1	567 [5019]	373 [3299]	351 [3104]	339 [3002]	1155 [10223]	2,71 [24]	53,90 [478]
ET014-100	100:1	346 [3058]	245 [2164]	214 [1892]	200 [1772]	1081 [9564]	2,71 [24]	38,50 [341]

<sup>1</sup> Ratios are exact, higher ratios are also available, consult factory.

T<sub>r</sub> = Rated output torque at rated speed for specific hours of life.

T<sub>rc</sub> = Rated output torque for intermittent operation at 3,000 RPM  
(20,000 hr life - for catalog comparison)

T<sub>peak</sub> = Allowable momentary peak torque for emergency stop or heavy shock loading.

J = Mass moment of inertia reflected to the input shaft (including pinion assembly).

### True Planetary Gearheads

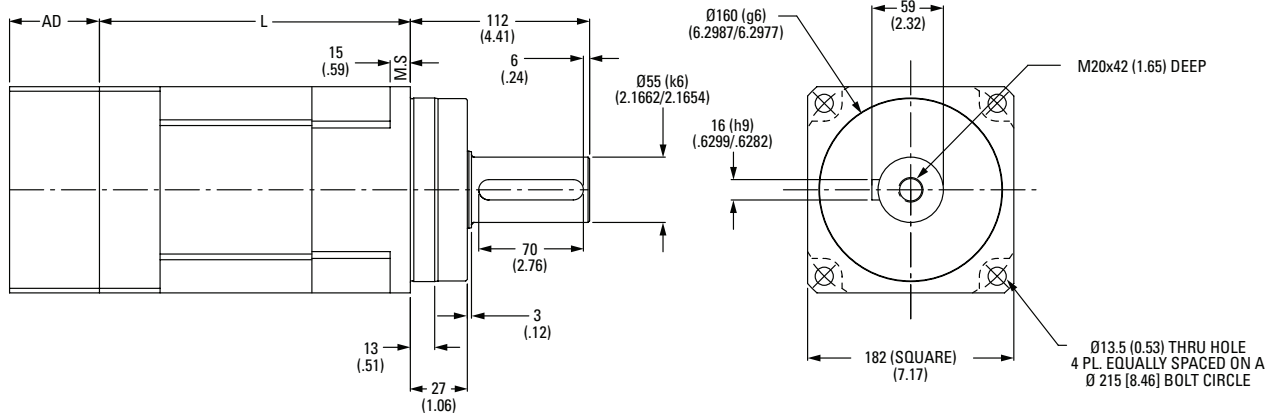

Ratio <sup>1</sup>	Stages	Dimension 'L' mm [in.]	Backlash [arc-min]	Weight kg [lb.]	Efficiency
4:1 to 10:1	1	136 [5.35]	4 max	40 [88]	95%
16:1 to 100:1	2	241.3 [9.50]	5 max	45 [99]	90%

All dimensions are in mm (in.)  
 AD\*\* = Adapter length  
 Adapter length will vary depending on motor.  
 Efficiency is calculated at 100% of the rated torque.

### Performance Specifications

Part Number	Ratio <sup>1</sup>	Intermittent (Trc) Nm [in.-lb.]	30000 Hour Life			T <sub>peak</sub> Nm [in.-lb.]	J kg-cm <sup>2</sup> [in.-lb.-sec <sup>2</sup> x10 <sup>-4</sup> ]	Torsional Stiffness Nm/arc-min [in.-lb./arc-min]
			T <sub>r</sub> (1000 rpm) Nm [in.-lb.]	T <sub>r</sub> (3000 rpm) Nm [in.-lb.]	T <sub>r</sub> (5000 rpm) Nm [in.-lb.]			
ET018-004	4:1	933 [8254]	802 [7099]	577 [5105]	495 [4380]	2442 [21609]	24,61 [218]	168,30 [1461]
ET018-005	5:1	972 [8602]	782 [6923]	601 [5321]	516 [4565]	2389 [21143]	19,00 [168]	165,00 [1461]
ET018-007	7:1	1037 [9174]	752 [6652]	641 [5675]	550 [4868]	2308 [20429]	13,87 [123]	147,40 [1306]
ET018-010	10:1	592 [5242]	430 [3806]	366 [3242]	338 [2990]	2210 [19561]	12,35 [109]	111,10 [984]
ET018-016	16:1	1335 [11816]	904 [8003]	826 [7309]	750 [6639]	2800 [24779]	15,30 [136]	177,10 [1569]
ET018-020	20:1	1363 [12061]	919 [8129]	843 [7460]	802 [7099]	2846 [25187]	14,82 [131]	171,60 [1520]
ET018-025	25:1	1325 [11722]	889 [7866]	819 [7251]	782 [6923]	2754 [24370]	14,82 [131]	144,10 [1277]
ET018-028	28:1	1403 [12414]	939 [8311]	868 [7679]	830 [7342]	2910 [25751]	12,83 [114]	151,80 [1345]
ET018-035	35:1	1361 [12047]	908 [8033]	842 [7452]	807 [7142]	2810 [24870]	10,83 [96]	136,40 [1209]
ET018-040	40:1	1443 [12767]	960 [8492]	892 [7897]	857 [7580]	2970 [26281]	10,83 [96]	177,10 [1569]
ET018-050	50:1	1398 [12371]	927 [8201]	865 [7652]	832 [7361]	2863 [25338]	10,36 [92]	171,60 [1520]
ET018-070	70:1	1332 [11789]	879 [7778]	824 [7292]	795 [7037]	2707 [23959]	10,36 [92]	151,80 [1345]
ET018-100	100:1	816 [7219]	578 [5117]	505 [4465]	472 [4180]	2537 [22454]	10,36 [92]	113,30 [1004]

<sup>1</sup> Ratios are exact, higher ratios are also available, consult factory.  
 T<sub>r</sub> = Rated output torque at rated speed for specific hours of life.  
 T<sub>rc</sub> = Rated output torque for intermittent operation at 3,000 RPM  
 (20,000 hr life - for catalog comparison)

T<sub>peak</sub> = Allowable momentary peak torque for emergency stop or heavy shock loading.  
 J = Mass moment of inertia reflected to the input shaft (including pinion assembly).

# Micron TRUE Planetary® Gearheads

## Radial and Axial Load Ratings

ET010

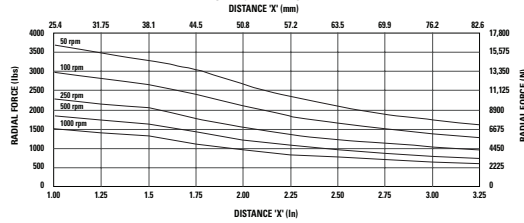
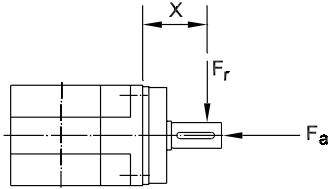

Speed rpm	Axial Load, $F_a$ N [lb.]
50	13675 [3075]
100	11107 [2497]
250	8435 [1897]
500	6855 [1542]
1000	5568 [1252]

ET014

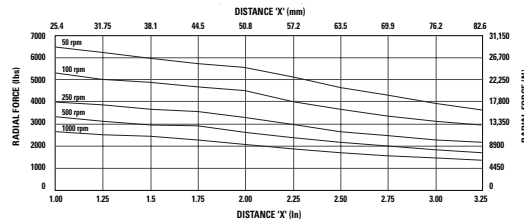
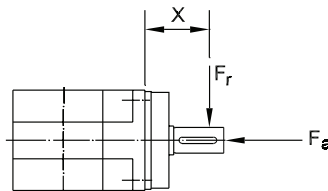

Speed rpm	Axial Load, $F_a$ N [lb.]
50	25074 [5705]
100	20609 [4633]
250	15657 [3520]
500	12716 [2859]
1000	10329 [2322]

ET018

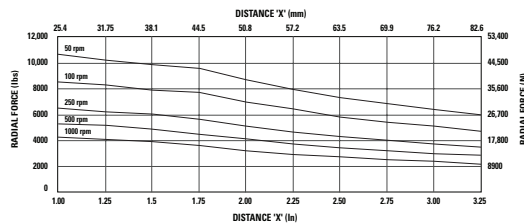
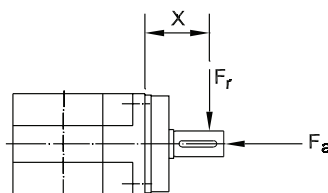

Speed rpm	Axial Load, $F_a$ N [lb.]
50	34538 [7765]
100	27414 [6163]
250	20197 [4541]
500	16034 [3605]
1000	12726 [2861]

These graphs display the allowable radial load at a given distance (X) from the mounting surface based on an  $L_{10}$  life of 10,000 hours for the mean output speed  $n_{mout}$ , as described on page 9.

# Micron TRUE Planetary® Gearheads

## DuraTRUE 90 Size 142H (Hollow Shaft)

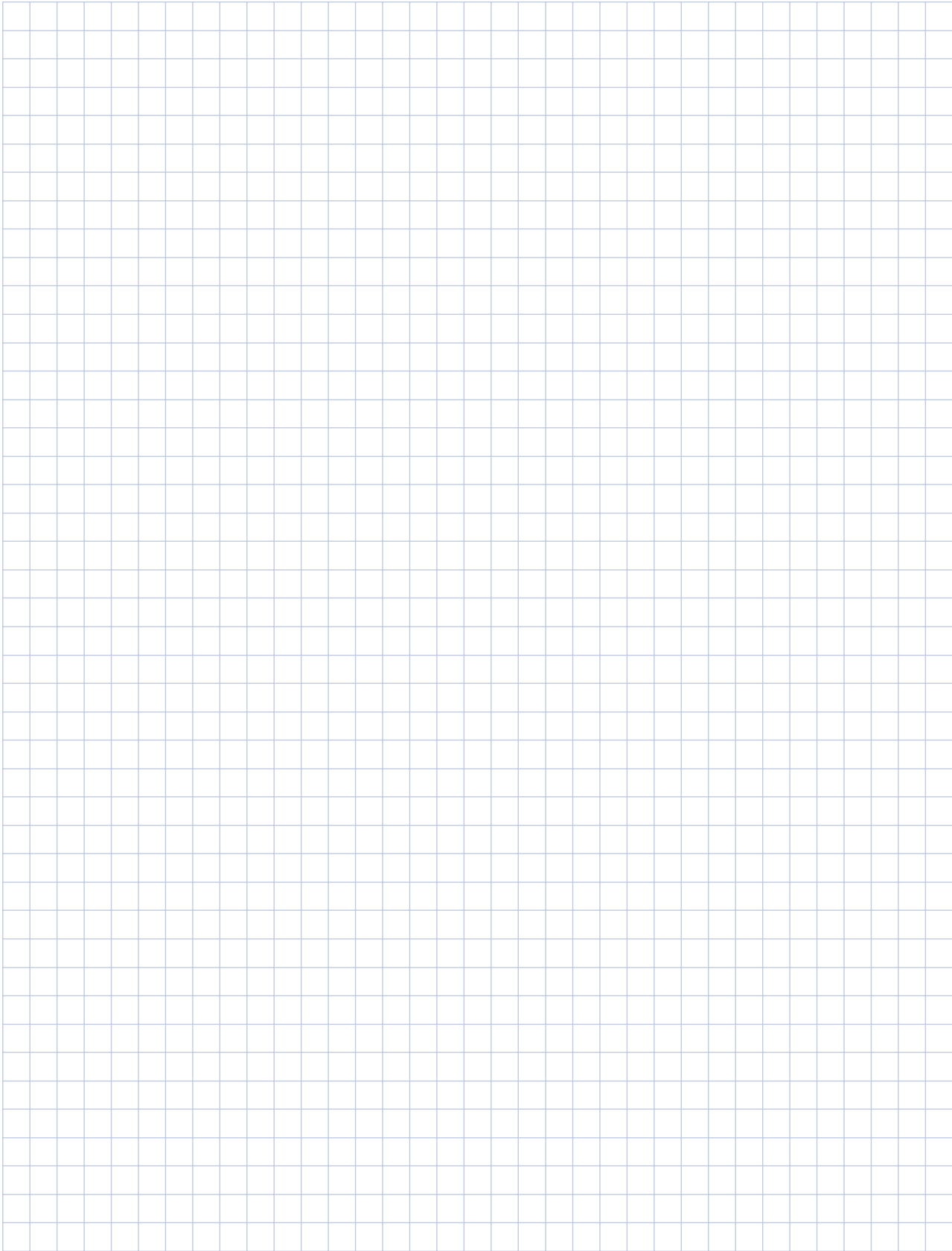

# Micron TRUE Planetary® Gearheads

## Gearhead Application Analysis Form

### General Information

Customer Name: \_\_\_\_\_ Fax: \_\_\_\_\_ Order Date: \_\_\_\_\_

Buyer Contact: \_\_\_\_\_ Phone: \_\_\_\_\_ Required Date: \_\_\_\_\_

Technical Contact: \_\_\_\_\_

Bill to Address: \_\_\_\_\_ Town/County: \_\_\_\_\_ State/Zip: \_\_\_\_\_

Ship to Address: \_\_\_\_\_ Town/County: \_\_\_\_\_ State/Zip: \_\_\_\_\_

E-mail: \_\_\_\_\_ Website: \_\_\_\_\_

### Motor Information

Motor Manufacturer: \_\_\_\_\_ Motor Model #: \_\_\_\_\_

Continuous Torque (Nm) \_\_\_\_\_ Peak Torque (Nm) \_\_\_\_\_

Maximum Speed (rpm) \_\_\_\_\_

### Application Information

Brief description of your application: \_\_\_\_\_

Acceleration time (sec) \_\_\_\_\_ Acceleration torque (Nm) \_\_\_\_\_ Max speed (rpm) \_\_\_\_\_

Dwell time (sec) \_\_\_\_\_ Dwell torque (Nm) \_\_\_\_\_ Dwell speed (rpm) \_\_\_\_\_

Deceleration time (sec) \_\_\_\_\_ Deceleration torque (Nm) \_\_\_\_\_ Min speed (rpm) \_\_\_\_\_

Radial Load (N) \_\_\_\_\_ Axial Load (N) \_\_\_\_\_ Target inertia match \_\_\_\_\_

External load inertia (Nm-sec<sup>2</sup>) \_\_\_\_\_ Maximum speed of motor (rpm) \_\_\_\_\_

### Ordering Information

Part Number	Quantity	Price	Delivery
-------------	----------	-------	----------

_____	_____	_____	_____
-------	-------	-------	-------

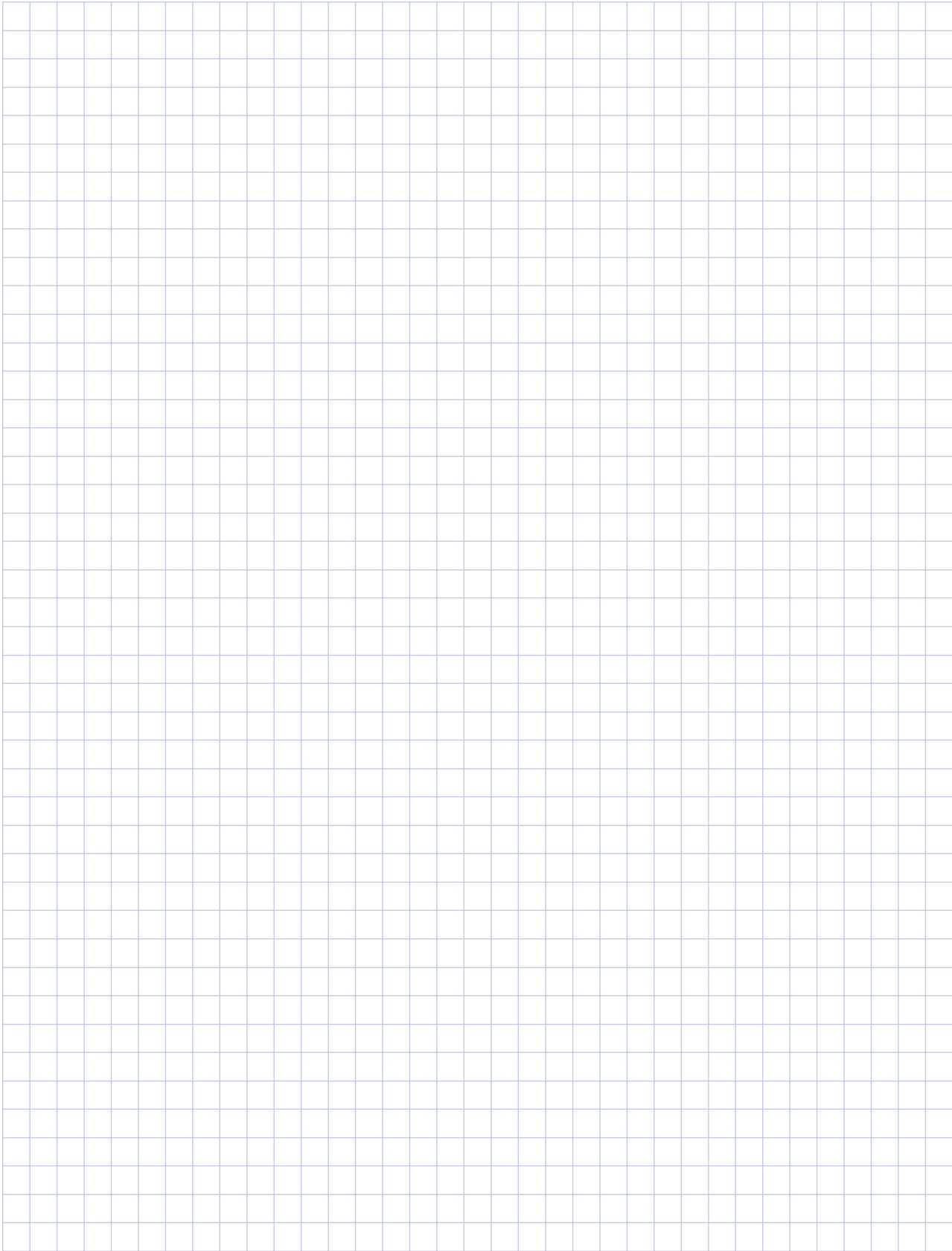

# Micron TRUE Planetary® Gearheads

## Gearhead Ordering Information

Visit [www.Micronmotioneering.com](http://www.Micronmotioneering.com) to get your complete RediMount part number using your motor manufacturer and model number information.

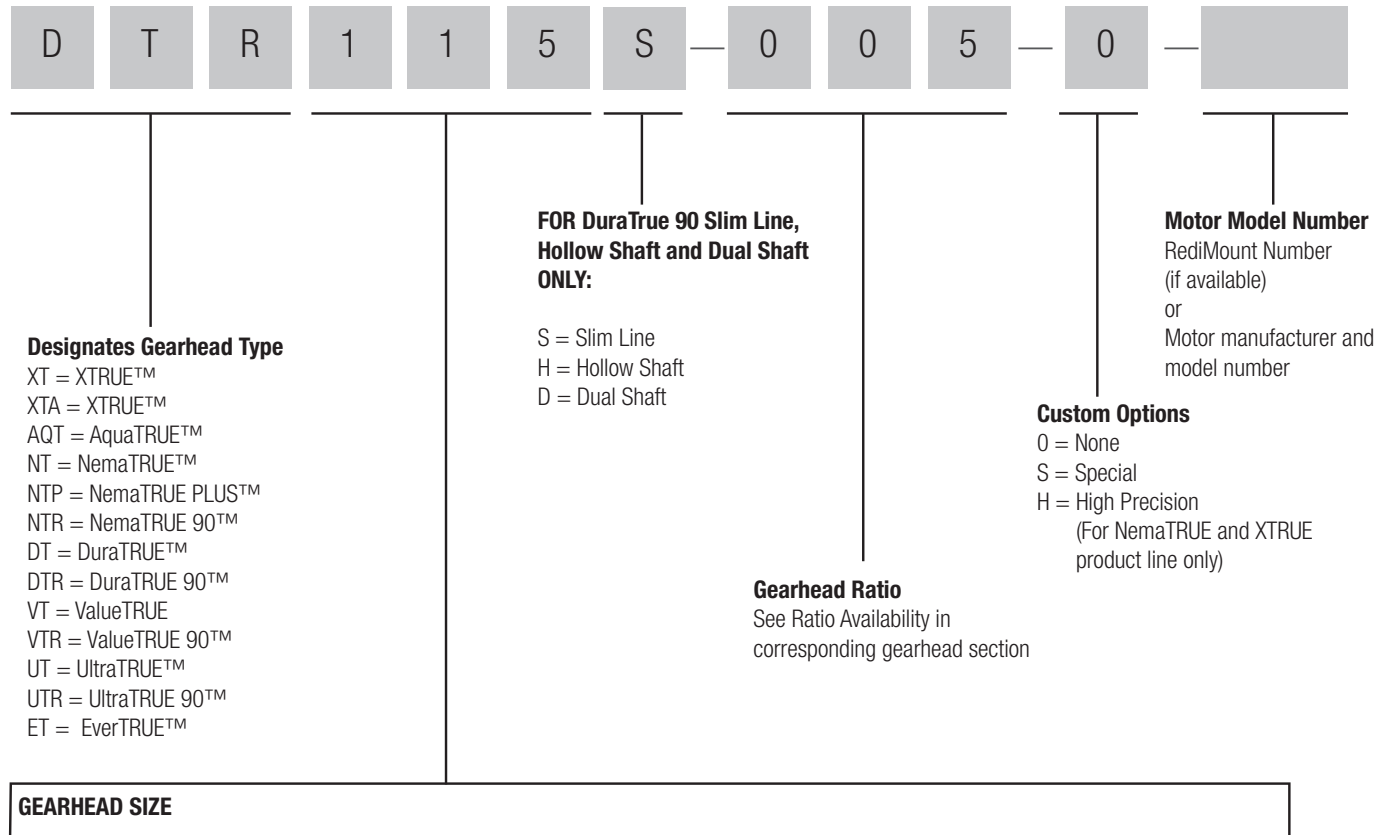

<b>XTRUE XT AquaTRUE</b>	<b>NemaTRUE NemaTRUE PLUS NemaTRUE 90</b>	<b>DuraTRUE DuraTRUE 90 DuraTRUE (Hollow Shaft) DuraTRUE (Dual Shaft)</b>	<b>UltraTRUE UltraTRUE 90</b>	<b>EverTRUE</b>	<b>ValueTRUE ValueTRUE 90</b>
040 = 40 mm	17 = Size 17	060 = Size 60	006 = Size 60	010 = Size 10	006 = Size 60
060 = 60 mm	23 = Size 23	090 = Size 90	075 = Size 75	014 = Size 14	075 = Size 75
080 = 80 mm	34 = Size 34	115 = Size 115	090 = Size 90	018 = Size 18	090 = Size 90
120 = 120 mm	42 = Size 42	142 = Size 142	010 = Size 10		010 = Size 10
160 = 160 mm	60 = Size 60		115 = Size 115		115 = Size 115
	90 = Size 90		014 = Size 14		014 = Size 14
<b>XTRUE XTA</b>	115 = Size 115		018 = Size 18		018 = Size 18
050 = 50 mm			022 = Size 22 (UltraTRUE only)		022 = Size 22
070 = 70 mm					
090 = 90 mm					
120 = 120 mm					



### Can't find what you need in this catalog?

Micron offers many different customization options to allow customers to meet the unique challenges of their applications.

#### Simple modifications that usually have little or no impact to price and lead time

- Output shaft modifications (shorter length or smaller diameter)
- Output shaft modifications (longer length or larger diameter would be product dependent)
- Custom output shaft designs (spline shafts, tapped holes)
- Higher precision options
- New ratio combinations (three stage designs, new ratios)
- Custom greases (food grade, low temperature, vacuum prep)
- Stainless steel, nickel plating or paint options

#### Other modifications that may require volume or longer lead time

- Envelope-size reductions (shorter length or width)
- Machined and mounted output gears
- Heavy shock and vibration requirements
- White paper, ground-up designs

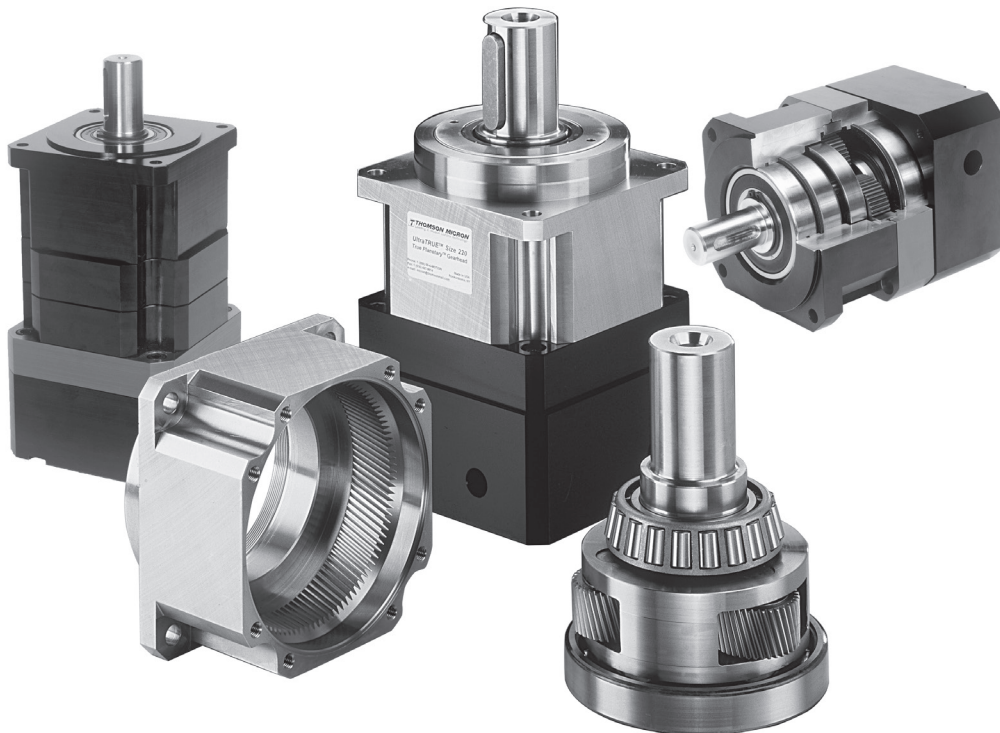

# Micron TRUE Planetary® Gearheads

---

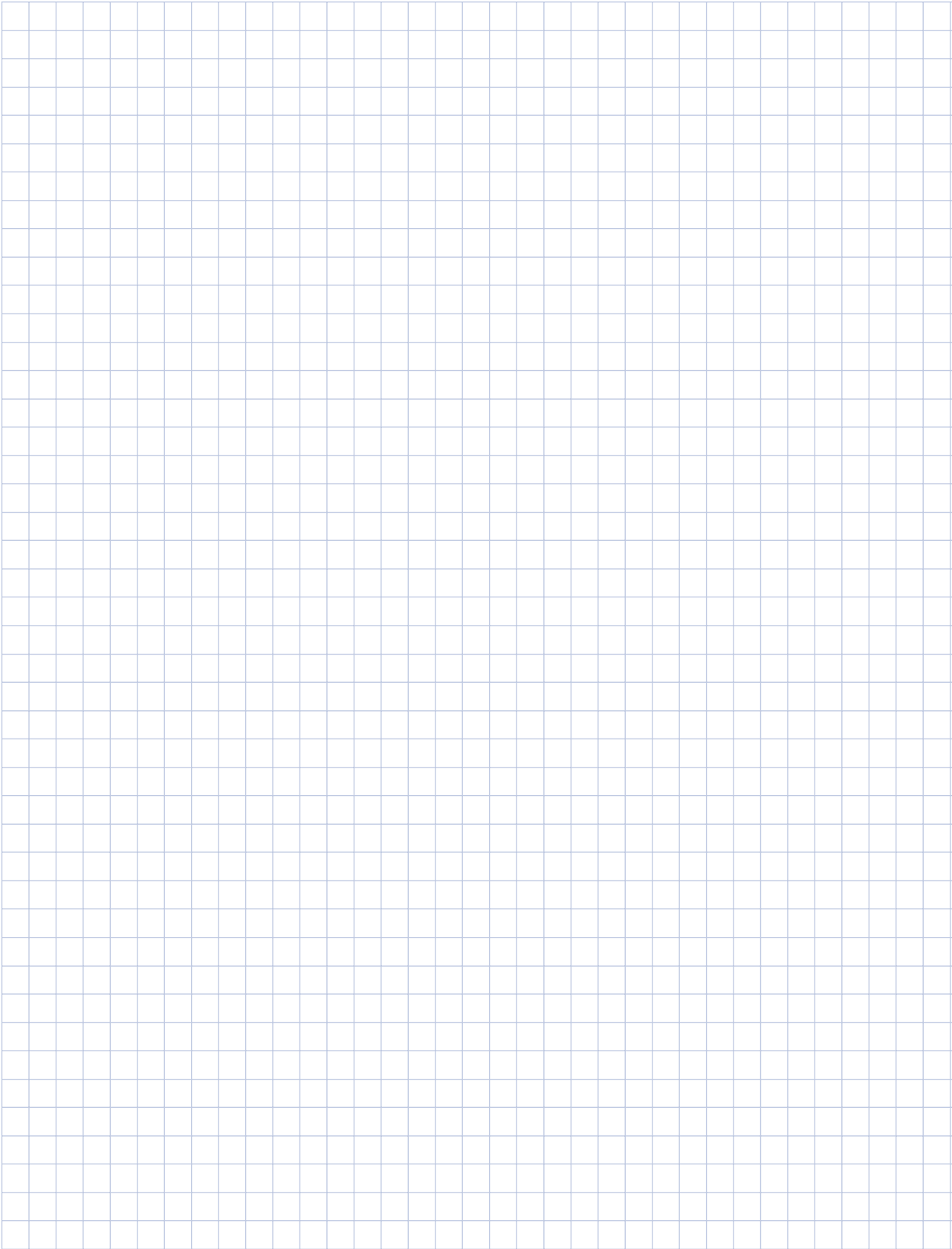

# Premier Industrial Company Leading Brands

## OTHER PRODUCT SOLUTIONS FROM **ALTRA MOTION**

Our comprehensive product offerings include various types of clutches and brakes, overrunning clutches, engineered bearing assemblies, gearing and gear motors along with linear motion products, belted drives, couplings, limit switches, precision motors, drives & controls, miniature motors and engine braking systems. With thousands of product solutions available, Altra provides true single source convenience while meeting specific customer requirements. Many major OEMs and end users prefer Altra products as their No. 1 choice for performance and reliability.

[WWW.ALTRAMOTION.COM](http://WWW.ALTRAMOTION.COM)



### **Electric Clutches & Brakes**

Inertia Dynamics  
Matrix  
Stromag  
Warner Electric



### **Precision Motors & Automation**

Kollmorgen



### **Heavy Duty Clutches & Brakes**

Industrial Clutch  
Stromag  
Svendborg Brakes  
Twiflex  
Wichita Clutch



### **Miniature Motors**

Portescap

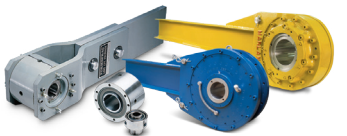

### **Overrunning Clutches**

Formsprag Clutch  
Marland Clutch  
Stieber



### **Linear Systems**

Thomson  
Warner Linear



### **Engineered Couplings & Universal Joints**

Ameridrives  
Bibby Turboflex  
Guardian Couplings  
Huco  
Lamiflex Couplings  
Stromag  
TB Wood's



### **Engine Braking Systems**

Jacobs Vehicle Systems



### **Gear Drives & Gear Motors**

Bauer Gear Motor  
Boston Gear  
Delroyd Worm Gear  
Nuttall Gear



### **Specialty Components**

Kilian  
Stromag  
TB Wood's

## Boston Gear Facilities

### North America

#### USA

701 Carrier Drive  
Charlotte, NC 28216 - USA  
704-588-5610

*Enclosed and Open Gearing,  
Electrical and Mechanical  
P.T. Components*

#### Customer Service

1-888-999-9860

#### Application Support

1-800-816-5608

## The Brands of Altra Motion

### Couplings

**Ameridrives**  
[www.ameridrives.com](http://www.ameridrives.com)

**Bibby Turboflex**  
[www.bibbyturboflex.com](http://www.bibbyturboflex.com)

**Guardian Couplings**  
[www.guardiancouplings.com](http://www.guardiancouplings.com)

**Huco**  
[www.huco.com](http://www.huco.com)

**Lamiflex Couplings**  
[www.lamiflexcouplings.com](http://www.lamiflexcouplings.com)

**Stromag**  
[www.stromag.com](http://www.stromag.com)

**TB Wood's**  
[www.tbwoods.com](http://www.tbwoods.com)

### Linear Systems

**Thomson**  
[www.thomsonlinear.com](http://www.thomsonlinear.com)

### Geared Cam Limit Switches

**Stromag**  
[www.stromag.com](http://www.stromag.com)

### Engineered Bearing Assemblies

**Kilian**  
[www.kilianbearings.com](http://www.kilianbearings.com)

### Electric Clutches & Brakes

**Matrix**  
[www.matrix-international.com](http://www.matrix-international.com)

**Stromag**  
[www.stromag.com](http://www.stromag.com)

**Warner Electric**  
[www.warnerelectric.com](http://www.warnerelectric.com)

### Belted Drives

**TB Wood's**  
[www.tbwoods.com](http://www.tbwoods.com)

### Heavy Duty Clutches & Brakes

**Twiflex**  
[www.twiflex.com](http://www.twiflex.com)

**Stromag**  
[www.stromag.com](http://www.stromag.com)

**Svendborg Brakes**  
[www.svendborg-brakes.com](http://www.svendborg-brakes.com)

**Wichita Clutch**  
[www.wichitaclutch.com](http://www.wichitaclutch.com)

### Gearing & Specialty Components

**Bauer Gear Motor**  
[www.bauergears.com](http://www.bauergears.com)

**Boston Gear**  
[www.bostongear.com](http://www.bostongear.com)

**Delevan**  
[www.delevan.com](http://www.delevan.com)

**Delroyd Worm Gear**  
[www.delroyd.com](http://www.delroyd.com)

**Nuttall Gear**  
[www.nuttallgear.com](http://www.nuttallgear.com)

### Engine Braking Systems

**Jacobs Vehicle Systems**  
[www.jacobsvehiclesystems.com](http://www.jacobsvehiclesystems.com)

### Precision Motors & Automation

**Kollmorgen**  
[www.kollmorgen.com](http://www.kollmorgen.com)

### Miniature Motors

**Portescap**  
[www.portescap.com](http://www.portescap.com)

### Overrunning Clutches

**Formsprag Clutch**  
[www.formsprag.com](http://www.formsprag.com)

**Marland Clutch**  
[www.marland.com](http://www.marland.com)

**Stieber**  
[www.stieberclutch.com](http://www.stieberclutch.com)

Neither the accuracy nor completeness of the information contained in this publication is guaranteed by the company and may be subject to change in its sole discretion. The operating and performance characteristics of these products may vary depending on the application, installation, operating conditions and environmental factors. The company's terms and conditions of sale can be viewed at <http://www.altramotion.com/terms-and-conditions/sales-terms-and-conditions>. These terms and conditions apply to any person who may buy, acquire or use a product referred to herein, including any person who buys from a licensed distributor of these branded products.

©2020 by Boston Gear LLC. All rights reserved. All trademarks in this publication are the sole and exclusive property of Boston Gear LLC or one of its affiliated companies.