



### QUICK SELECTION / Selezione veloce

input speed ( $n_1$ ) = 1400 min<sup>-1</sup>

Output Speed $n_2$ [min <sup>-1</sup> ]	Ratio $i$	Motor power $P_{1M}$ [kW]	Output torque $M_{2M}$ [Nm]	Service factor f.s.	Nominal power $P_{1R}$ [kW]	Nominal torque $M_{2R}$ [Nm]	Available B5 motor flanges			B14 motor flanges not available				Dynamic efficiency  RD	Tooth Module  Mn [mm]	Ratios code 
							E	F	G	-	-	-	-			
186.7	7.5	7.5	345	2.1	16.1	741								90	6.11	01
140	10	7.5	455	1.8	13.5	820								89	6.45	02
93.3	15	7.5	668	1.4	10.3	917								87	6.72	03
70	20	7.5	870	1.0	7.8	905								85	5.24	04
56	25	5.5	788	1.2	6.5	931								84	4.28	05
46.7	30	5.5	900	1.2	6.4	1047								80	6.91	06
35	40	4.0	851	1.2	4.9	1043								78	5.36	07
28	50	4.0	1023	0.9	3.8	972								75	4.35	08
23.3	60	3.0	896	1.0	3.1	928	B							73	3.65	09
17.5	80	2.2	816	1.0	2.3	853	B							68	2.76	10
14	100	1.5	655	1.1	1.7	742	B							64	2.23	11

**Motor Flanges Available**  
Flange Motore Disponibili

**B) Supplied with Reduction Bushing**  
Fornito con Bussola di Riduzione

**B) Available on Request without reduction bushing**  
Disponibile a Richiesta senza Bussola di Riduzione

**C) Motor Flange Holes Position**  
Posizione Fori Flangia Motore

**EN** Unit Q13 is supplied without lubricant and equipped with a breather, level and drain plugs. User can add mineral oil keeping existing plugs. Should the user wish to fill it with synthetic oil, it is recommended to replace the existing plugs with a closed plug. See table 1 for lubrication and recommended quantity. In table 2 please see possible radial loads and axial loads on the gearbox. For complete documentation please visit our web site.

**I** Il riduttore tipo Q13 è fornito privo di lubrificazione con tappi di sfiato, livello e scarico olio. L'utente può immettere olio minerale mantenendo i tappi esistenti. Se immetterà olio sintetico, dovrà sostituire i tappi esistenti con altri tipo chiuso. Tab.1 per oli e quantità consigliati. Tab.2 carichi radiali e assiali applicabili al riduttore. Per la documentazione completa consulta il nostro sito.

**D** Das Getriebe der Baugröße Q13 wird ohne Schmiermittel geliefert. Es ist jedoch mit Einfüllschraube, Überdruckventil und Ablassschraube ausgerüstet. Das benötigte mineralische Öl kann über die Einfüllschraube eingefüllt werden. Sollte synthetisches Öl bevorzugt werden, so ist sind das eingebaute Überdruckventil durch eine geschlossenen Schraube zu ersetzen. In Tabelle 1 ist die Schmiermenge und das empfohlene Schmiermittel angegeben. In Tabelle 2 sind die zulässigen Radial - und Axialbelastungen des Getriebes aufgeführt. Die komplette Dokumentation, Wartungs - und Inbetriebnahmeanleitungen finden Sie unter.

**E** El reductor tamaño Q13 se suministra sin lubricante, provisto de tapones de respiración, nivel y descarga de aceite. El usuario puede utilizar aceite mineral, manteniendo los tapones existentes. Si prefiere utilizar aceite sintético deberá sustituir los tapones existentes por tapones ciegos. La prerreducción se suministra con tapones ciegos, lubricado de por vida con aceite sintético. Ver tabla 1, para cantidades y aceites recomendados. En la tabla 2, se encuentran las cargas radiales y axiales admitidas por el reductor. Para documentación completa, consultar nuestra Web.

B3	B6	B7	B8	V5	V6
4.50 LT	3.50 LT	3.50 LT	3.30LT	4.50 LT	3.30LT
<b>AGIP</b>	<b>BP</b>	<b>SHELL</b>	<b>KLUBER</b>	<b>MOBIL</b>	
Telium VSF 320	Energol SGXP220	Tivela Oil WB	Syntheso D220 EF	Glygoyl 30	

tab. 1

### RADIAL AND AXIAL LOADS

**Output shaft**  
Albero di uscita

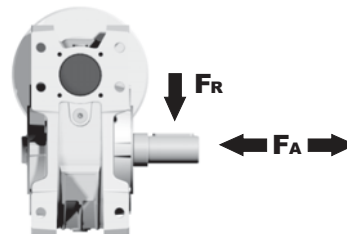

$n_2$ [min <sup>-1</sup> ]	FA [N]	FR [N]
200	960	4800
150	1100	5500
100	1240	6200
75	1380	6900
50	1560	7800
25	2000	10000
15	2400	12000

**Input shaft**  
albero in entrata

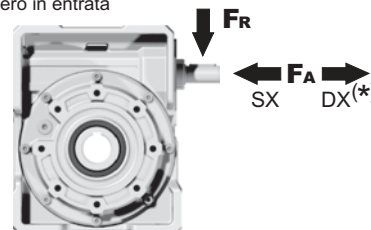

$n_1$ [min <sup>-1</sup> ]	FA [N]	FR [N]
1400	300	1500

\*Strong axial loads in the DX direction are not allowed.  
Non sono consentiti forti carichi assiali con direzione DX

tab. 2

**SELECT THIS TYPE AND THIS SPECIFIC SIZE ON THE WEB PAGES TO GET COMPLETE TECHNICAL DATA.**  
Selezionare tipo e gandezza specifica nel sito web per la documentazione completa.

PQ13**FB**... Basic wormbox  
Riduttore base

Gearbox weight  
peso riduttore **48.0 kg**

M. flanges	Kit code	øF	A
90B5	KQ13.4.041	200	180
100/112B5	KQ13.4.042	250	180
132B5	KQ13.4.043	300	180

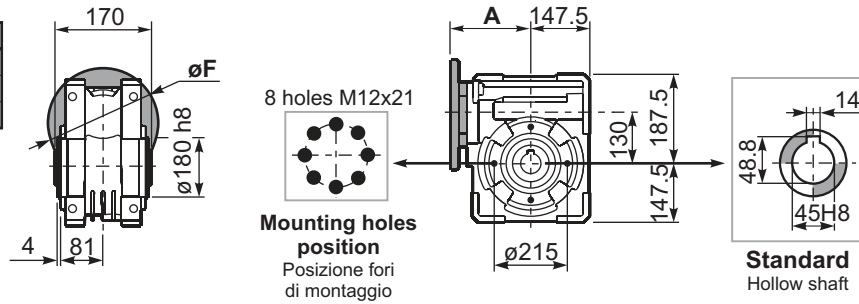

PQ13**FC**... Square flange  
Flangia quadrata

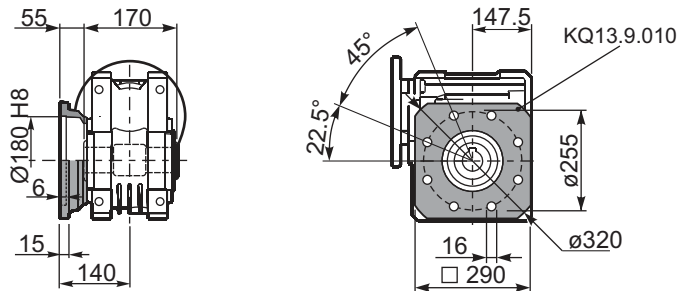

PQ13**FB**... Feet  
Piedini

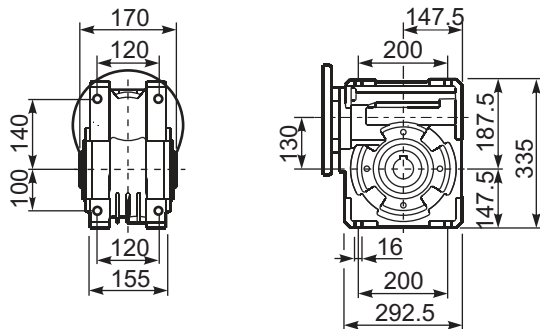

PQ13**BR**... Reaction arm  
Braccio di reazione

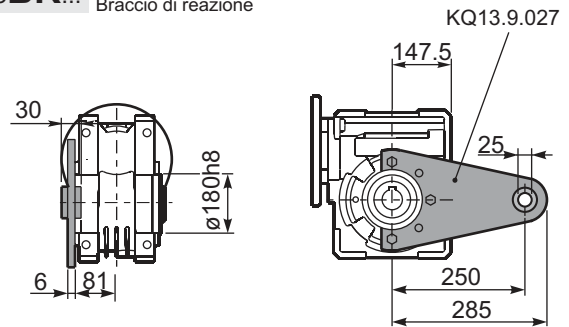

PQ13.....**S**... Single Shaft  
Albero lento semplice

PQ13.....**D**... Double Shaft  
Albero lento bisp.

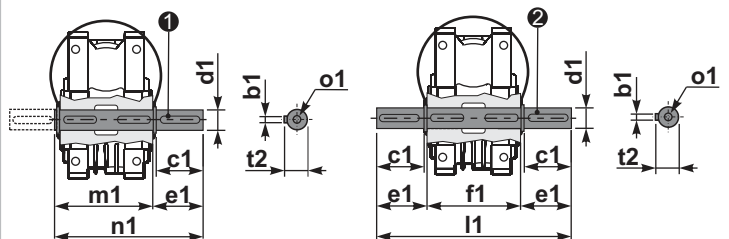

① kit cod. KQ13.5.028 type B

② kit cod. KQ13.5.029 type B

	b1	c1	d1	e1	f1	l1	m1	n1	t2	o1
type	14	80	45 <sup>-0.005</sup> <sub>-0.020</sub>	85	170	340	180	265	48.5	M16
type	-	-	-	-	-	-	-	-	-	-