

### Calculation and dimensioning

In order to guarantee the long life time of the shock absorber it must be correctly calculated and dimensioned. For that the following parameters must be considered:

- moving mass [kg]
- impact velocity of moving mass onto the shock absorber [m/s]
- additional acting propelling force, motor power or propelling torque [N, kW, Nm]
- number of parallel acting shock absorbers [n]
- number of strokes or cycles per hour [1/h]

### WARNING

⚠ The shock absorbers have to be dimensioned in such a way that the calculated values do not exceed the maximum values of the individual capacity chart (see main catalogue):  
 $W_3$  [Nm/stroke]  
 $W_4$  [Nm/h]  
 effective weight me  
 max. side load angle [°]

⚠ To correctly calculate the shock absorber it must be the only active brake system in place. Additional deceleration systems, such as pneumatic cushioning, must be rendered ineffective and not allowed to interfere with the shock absorber deceleration.

The correct dimensioning of shock absorbers can be made with the ACE online calculation program at [www.ace-ace.com](http://www.ace-ace.com). Alternatively the filled out online form may be sent to us via E-Mail. Or call our free of charge calculation service: +49-2173-9226-20

### Installation information and initial start-up

Prior to installation and use, check if the identification number on the shock absorber or on the package corresponds to the number on the delivery sheet. Industrial shock absorbers are maintenance-free and ready-to-fit.

### WARNING

⚠ Thermal effect: The values given in the capacity chart  $W_4$  and me (see main catalogue) are valid for room temperature. Different values apply for higher temperatures.

**Mounting:** In any position, but always so that the complete stroke can be used. The shock absorber is to be mounted so that the forces can be guided centrally via the piston rod. The maximum permissible side load (see main catalogue) may not be exceeded. An existing side load leads generally to a reduced lifetime. When exceeding the maximum permissible side load, a side load adaptor must be used.

**Operating temperature range:** -12 °C to 70 °C

**Adjustment:** The scale displays a setting range between 0 to 9. The adjustment can be made via an adjustment screw at the bottom or at the adjusting ring on the stop collar. Both adjustment options are connected and show identical values on the scale. The equipment should be adjusted several times after mounting the shock absorber, using either the stop collar or the adjustment screw until the optimum deceleration (no hard impact at either the beginning or the end of stroke) is achieved.

Hard impact at the beginning of stroke, turn scale towards 9.

Hard impact at the end of stroke, turn scale towards 0.

The shock absorber is always preset to 5 upon delivery.

WARNING	
⚠	Moving masses can lead to injuries or bodily harm when installing the shock absorber. Secure moving masses against accidental movement.
⚠	The shock absorbers may be unsuitable for the application and show insufficient damping performance. Check for proper suitability of shock absorber.
⚠	When operating outside the allowed temperature range, the shock absorber may lose its function. Permissible temperature range must be adhered to. Do not paint the shock absorber due to heat radiation.
⚠	Ambient fluids, gases and dirt particles may affect or damage the sealing system and lead to failure of the shock absorber. Piston rods and sealing systems must be protected against foreign substances.
⚠	Damage to the piston rod surface may destroy the sealing system. Do not grease, oil, etc. the piston rod and protect it from dirt particles.
⚠	The piston rod can be torn out of the shock absorber. Do not put tensile stress on the piston rod.
⚠	The shock absorber can tear off upon impact. The connection must be calculated so that the maximum operating reaction forces can be accepted with sufficient safety. The maximum reaction forces given in the calculation report may deviate from the actual reaction forces since these are based on theoretical values.

**Disposal of packaging:** Dispose packaging in an environmentally safe manner. The recycling of packaging saves raw materials and lowers the amount of waste. The used packaging materials do not contain illegal substances.

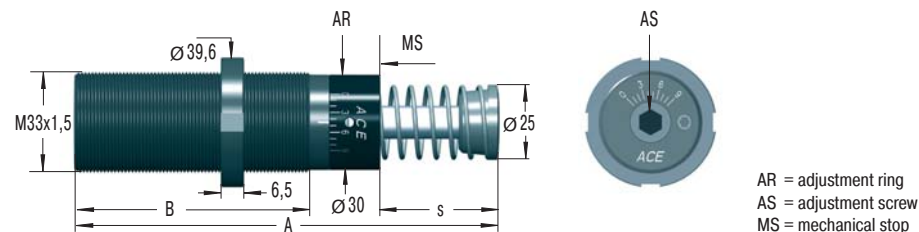

AR = adjustment ring  
 AS = adjustment screw  
 MS = mechanical stop

### Dimensions

Type	s (stroke)	A max	B
Part Number			
MA3325EUM	23	138	83
MA3350EUM	48.5	189	108

### Mounting Options

#### Mounting with square flange QF

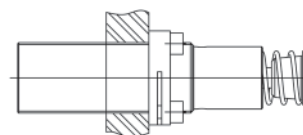

Install with 4 machine screws  
 Tightening torque: 11 Nm  
 Clamping torque: > 90 Nm

#### Mounting the shock absorbers in the tapped hole with two locking rings

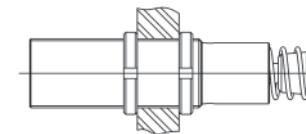

Tightening torque: 80 Nm

#### Side foot mounting S

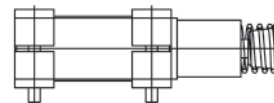

S33 = 2 flanges + 4 screws M6x40, DIN 912  
 Because of the thread pitch the fixing holes for the second foot mount should only be drilled and tapped after the first foot mount has been fixed in position.  
 Tightening torque: 11 Nm (screws)  
 Clamping torque: > 90 Nm

#### Screwing in the shock absorbers into a tapped hole with an additional locking ring

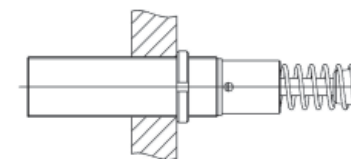

Tightening torque: 80 Nm

### Accessories

When using accessories and mounting elements, pay attention to the separate mounting instructions.

### EU Marking

Starting with the production date September 2010 (Code IB or 10244) all shock absorbers are to be marked with an additional EU letter code in the identification number. The EU marking refers to the adherence to the required norms, laws, and guidelines of the EU. Only products marked with EU ensure the world wide standard and the guarantee for liability.

Issue 8.2010 - Specifications subject to change

Issue 8.2010 - Specifications subject to change

### Calculation and dimensioning

In order to guarantee the long life time of the shock absorber it must be correctly calculated and dimensioned. For that the following parameters must be considered:

- moving mass [kg]
- impact velocity of moving mass onto the shock absorber [m/s]
- additional acting propelling force, motor power or propelling torque [N, kW, Nm]
- number of parallel acting shock absorbers [n]
- number of strokes or cycles per hour [1/h]

### WARNING

- ⚠ The shock absorbers have to be dimensioned in such a way that the calculated values do not exceed the maximum values of the individual capacity chart (see main catalogue):  
 $W_3$  [Nm/stroke]  
 $W_4$  [Nm/h]  
 effective weight me  
 max. side load angle [°]
- ⚠ To correctly calculate the shock absorber it must be the only active brake system in place. Additional deceleration systems, such as pneumatic cushioning, must be rendered ineffective and not allowed to interfere with the shock absorber deceleration.

The correct dimensioning of shock absorbers can be made with the ACE online calculation program at [www.ace-ace.com](http://www.ace-ace.com). Alternatively the filled out online form may be sent to us via E-Mail. Or call our free of charge calculation service: +49-2173-9226-20

### Installation information and initial start-up

Prior to installation and use, check if the identification number on the shock absorber or on the package corresponds to the number on the delivery sheet. Industrial shock absorbers are maintenance-free and ready-to-fit.

### WARNING

- ⚠ **Thermal effect:** The values given in the capacity chart  $W_4$  and  $m_e$  (see main catalogue) are valid for room temperature. Different values apply for higher temperatures.

**Mounting:** In any position, but always so that the complete stroke can be used. The shock absorber is to be mounted so that the forces can be guided centrally via the piston rod. The maximum permissible side load (see main catalogue) may not be exceeded. An existing side load leads generally to a reduced lifetime. When exceeding the maximum permissible side load, a side load adaptor must be used.

**Operating temperature range:** -12 °C to 70 °C

**Adjustment:** The scale displays a setting range between 0 to 9. The adjustment can be made via an adjustment screw at the bottom or at the adjusting ring on the stop collar. Both adjustment options are connected and show identical values on the scale. The equipment should be adjusted several times after mounting the shock absorber, using either the stop collar or the adjustment screw until the optimum deceleration (no hard impact at either the beginning or the end of stroke) is achieved.

Hard impact at the beginning of stroke, turn scale towards 9.

Hard impact at the end of stroke, turn scale towards 0.

The shock absorber is always preset to 5 upon delivery.

### WARNING

- ⚠ **Moving masses can lead to injuries or bodily harm when installing the shock absorber.**  
Secure moving masses against accidental movement.
- ⚠ **The shock absorbers may be unsuitable for the application and show insufficient damping performance.**  
Check for proper suitability of shock absorber.
- ⚠ **When operating outside the allowed temperature range, the shock absorber may lose its function.**  
Permissible temperature range must be adhered to. Do not paint the shock absorber due to heat radiation.
- ⚠ **Ambient fluids, gases and dirt particles may affect or damage the sealing system and lead to failure of the shock absorber.**  
Piston rods and sealing systems must be protected against foreign substances.
- ⚠ **Damage to the piston rod surface may destroy the sealing system.**  
Do not grease, oil, etc. the piston rod and protect it from dirt particles.
- ⚠ **The piston rod can be torn out of the shock absorber.**  
Do not put tensile stress on the piston rod.
- ⚠ **The shock absorber can tear off upon impact. The connection must be calculated so that the maximum operating reaction forces can be accepted with sufficient safety. The maximum reaction forces given in the calculation report may deviate from the actual reaction forces since these are based on theoretical values.**

**Disposal of packaging:** Dispose packaging in an environmentally safe manner. The recycling of packaging saves raw materials and lowers the amount of waste. The used packaging materials do not contain illegal substances.

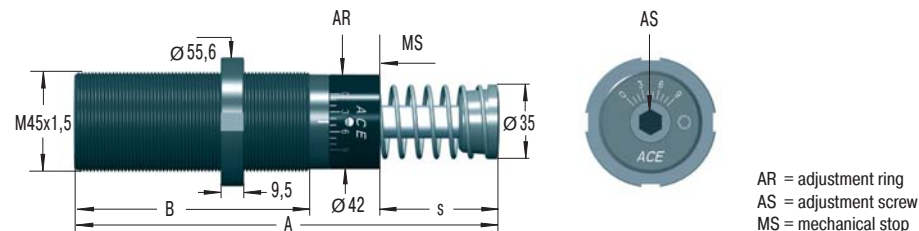

AR = adjustment ring  
 AS = adjustment screw  
 MS = mechanical stop

### Dimensions

Type Part Number	s (stroke)	A max	B
MA4525EUM	23	145	95
MA4550EUM	48.5	195	120
MA4575EUM	74	246	145

### Mounting Options

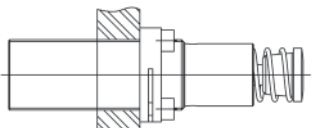
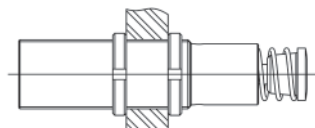
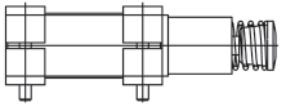
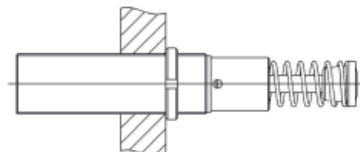
<p><b>Mounting with square flange QF</b></p>  <p>Install with 4 machine screws              Tightening torque: 27 Nm              Clamping torque: &gt; 200 Nm</p>	<p><b>Mounting the shock absorbers in the tapped hole with two locking rings</b></p>  <p>Tightening torque: 235 Nm</p>
<p><b>Side foot mounting S</b></p>  <p>S45 = 2 flanges + 4 screws M8x50, DIN 912              Because of the thread pitch the fixing holes for the second foot mount should only be drilled and tapped after the first foot mount has been fixed in position.              Tightening torque: 27 Nm (screws)              Clamping torque: &gt; 350 Nm</p>	<p><b>Screwing in the shock absorbers into a tapped hole with an additional locking ring</b></p>  <p>Tightening torque: 235 Nm</p>

### Accessories

When using accessories and mounting elements, pay attention to the separate mounting instructions.

### EU Marking

Starting with the production date September 2010 (Code IB or 10244) all shock absorbers are to be marked with an additional EU letter code in the identification number. The EU marking refers to the adherence to the required norms, laws, and guidelines of the EU. Only products marked with EU ensure the world wide standard and the guarantee for liability.

Issue 8.2010 Specifications subject to change

Issue 8.2010 Specifications subject to change

### Calculation and dimensioning

In order to guarantee the long life time of the shock absorber it must be correctly calculated and dimensioned. For that the following parameters must be considered:

- moving mass [kg]
- impact velocity of moving mass onto the shock absorber [m/s]
- additional acting propelling force, motor power or propelling torque [N, kW, Nm]
- number of parallel acting shock absorbers [n]
- number of strokes or cycles per hour [1/h]

#### WARNING

- ⚠ The shock absorbers have to be dimensioned in such a way that the calculated values do not exceed the maximum values of the individual capacity chart (see main catalogue):  
 $W_3$  [Nm/stroke]  
 $W_4$  [Nm/h]  
 effective weight me  
 max. side load angle [°]
- ⚠ To correctly calculate the shock absorber it must be the only active brake system in place. Additional deceleration systems, such as pneumatic cushioning, must be rendered ineffective and not allowed to interfere with the shock absorber deceleration.

The correct dimensioning of shock absorbers can be made with the ACE online calculation program at [www.ace-ace.com](http://www.ace-ace.com). Alternatively the filled out online form may be sent to us via E-Mail. Or call our free of charge calculation service: +49-2173-9226-20

### Installation information and initial start-up

Prior to installation and use, check if the identification number on the shock absorber or on the package corresponds to the number on the delivery sheet. Industrial shock absorbers are maintenance-free and ready-to-fit.

#### WARNING

- ⚠ **Thermal effect:** The values given in the capacity chart  $W_4$  and me (see main catalogue) are valid for room temperature. Different values apply for higher temperatures.

**Mounting:** In any position, but always so that the complete stroke can be used. The shock absorber is to be mounted so that the forces can be guided centrally via the piston rod. The maximum permissible side load (see main catalogue) may not be exceeded. An existing side load leads generally to a reduced lifetime. When exceeding the maximum permissible side load, a side load adaptor must be used.

**Operating temperature range:** -12 °C to 70 °C

**Adjustment:** The scale displays a setting range between 0 to 9. The adjustment can be made via an adjustment screw at the bottom or at the adjusting ring on the stop collar. Both adjustment options are connected and show identical values on the scale. The equipment should be adjusted several times after mounting the shock absorber, using either the stop collar or the adjustment screw until the optimum deceleration (no hard impact at either the beginning or the end of stroke) is achieved.

Hard impact at the beginning of stroke, turn scale towards 9.

Hard impact at the end of stroke, turn scale towards 0.

The shock absorber is always preset to 5 upon delivery.

#### WARNING

- ⚠ Moving masses can lead to injuries or bodily harm when installing the shock absorber.  
Secure moving masses against accidental movement.
- ⚠ The shock absorbers may be unsuitable for the application and show insufficient damping performance.  
Check for proper suitability of shock absorber.
- ⚠ When operating outside the allowed temperature range, the shock absorber may lose its function.  
Permissible temperature range must be adhered to. Do not paint the shock absorber due to heat radiation.
- ⚠ Ambient fluids, gases and dirt particles may affect or damage the sealing system and lead to failure of the shock absorber. Piston rods and sealing systems must be protected against foreign substances.
- ⚠ Damage to the piston rod surface may destroy the sealing system.  
Do not grease, oil, etc. the piston rod and protect it from dirt particles.
- ⚠ The piston rod can be torn out of the shock absorber.  
Do not put tensile stress on the piston rod.
- ⚠ The shock absorber can tear off upon impact. The connection must be calculated so that the maximum operating reaction forces can be accepted with sufficient safety. The maximum reaction forces given in the calculation report may deviate from the actual reaction forces since these are based on theoretical values.

**Disposal of packaging:** Dispose packaging in an environmentally safe manner. The recycling of packaging saves raw materials and lowers the amount of waste. The used packaging materials do not contain illegal substances.

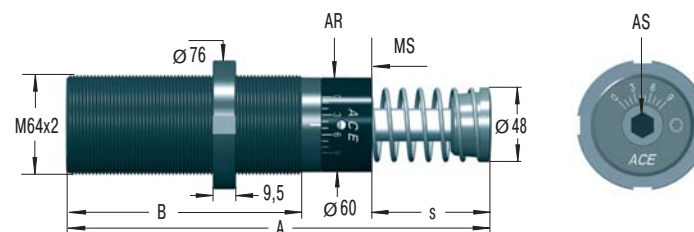

AR = adjustment ring  
AS = adjustment screw  
MS = mechanical stop

150 mm stroke model does not include stop collar and positive stop is provided by the rod button which is 60 mm dia.

### Dimensions

Type	s (stroke)	A max	B
Part Number			
MA6450EUM	48.5	225	140
MA64100EUM	99.5	326	191
MA64150EUM	150	450	241

### Mounting Options

#### Mounting with square flange QF

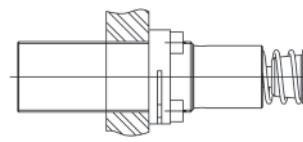

Install with 4 machine screws  
Tightening torque: 50 Nm  
Clamping torque: > 210 Nm

#### Mounting the shock absorbers in the tapped hole with two locking rings

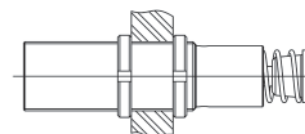

Tightening torque: 780 Nm

#### Side foot mounting S

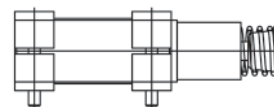

S64 = 2 flanges + 4 screws M10x80, DIN 912  
Because of the thread pitch the fixing holes for the second foot mount should only be drilled and tapped after the first foot mount has been fixed in position.  
Tightening torque: 50 Nm (screws)  
Clamping torque: > 350 Nm

#### Screwing in the shock absorbers into a tapped hole with an additional locking ring

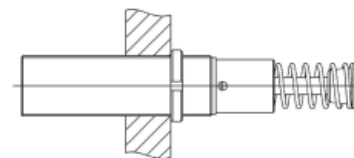

Tightening torque: 780 Nm

### Accessories

When using accessories and mounting elements, pay attention to the separate mounting instructions.

### EU Marking

Starting with the production date September 2010 (Code IB or 10244) all shock absorbers are to be marked with an additional EU letter code in the identification number. The EU marking refers to the adherence to the required norms, laws, and guidelines of the EU. Only products marked with EU ensure the world wide standard and the guarantee for liability.

Issue 8.2010 - Specifications subject to change

Issue 8.2010 - Specifications subject to change