

6.20 Single disc brake type ESB



Single disc brake manual



Single disc brake pneumatic



Single disc brake with membrane cylinder I



Single disc brake with membrane cylinder II

	ESB			
	manual	pneumatic	membrane I	membrane II
type 19-25				
performance kW (h.p.)	0.15 (0.201)	0.15 (0.201)	0.15 (0.201)	0.15 (0.201)
max. brake torque Nm (ft/lb)	40 (29,5)	40 (29,5)	40 (29,5)	90 (66,4)
type 22-30				
performance kW (h.p.)	0.15 (0.201)	0.15 (0.201)	0.15 (0.201)	0.15 (0.201)
max. brake torque Nm (ft/lb)	40 (29,5)	40 (29,5)	40 (29,5)	90 (66,4)
type 30-40 / A40				
performance kW (h.p.)	0.15 (0.201)	0.15 (0.201)	0.15 (0.201)	0.15 (0.201)
max. brake torque Nm (ft/lb)	40 (29,5)	40 (29,5)	40 (29,5)	90 (66,4)
type 40-50 / A50				
performance kW (h.p.)	0.2 (0.268)	0.2 (0.268)	0.2 (0.268)	0.2 (0.268)
max. brake torque Nm (ft/lb)	50 (36,9)	50 (36,9)	50 (36,9)	110 (81,1)

All data is on a basis of 5 bar (72,5 psi) pressure.

Safety Chuck with manual single disc brake

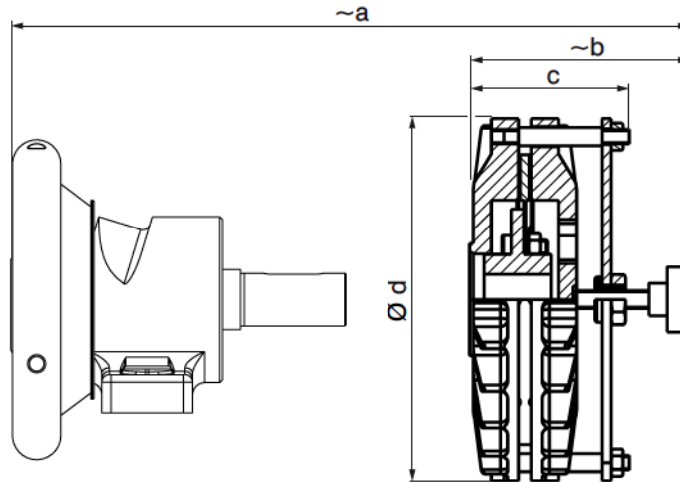

picture of chuck just symbolic

	a	b	c	d
Safety Chuck 19-25 + ESB manual	235	118	86	200
Safety Chuck 22-30 + ESB manual	241	118	86	200
Safety Chuck 30-40 + ESB manual	258	118	86	200
Safety Chuck 40-50 + ESB manual	327	136.5	110	235

Dimension schedule for Boschert-Chuck see chapter 2.10 - 2.40

Safety chuck with pneumatic single disc brake

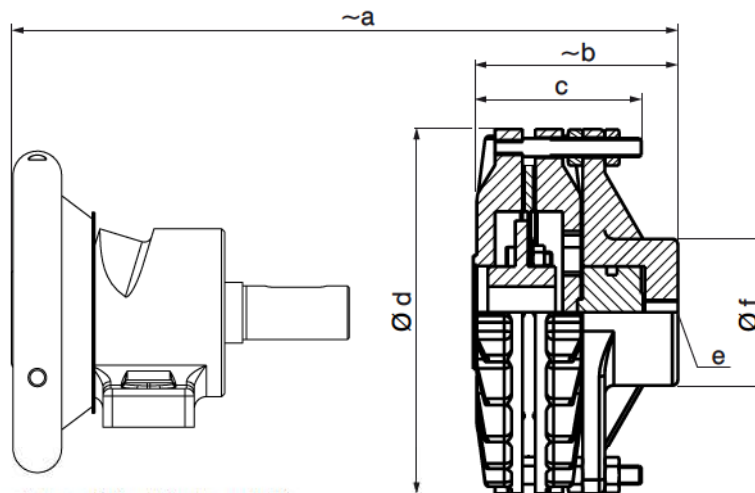

picture of chuck just symbolic

	a	b	c	d	e	f
Safety Chuck 19-25 + ESB pneumatic	227	110	90	200	G 1/4	80
Safety Chuck 22-30 + ESB pneumatic	233	110	90	200	G 1/4	80
Safety Chuck 30-40 + ESB pneumatic	250	110	90	200	G 1/4	80
Safety Chuck 40-50 + ESB pneumatic	324	133.5	107	235	G 1/4	80

Dimension schedule for Boschert-Chuck see chapter 2.10 - 2.40

ESB and membrane cylinder I / II

Safety chuck with single disc brake and membrane cylinder I

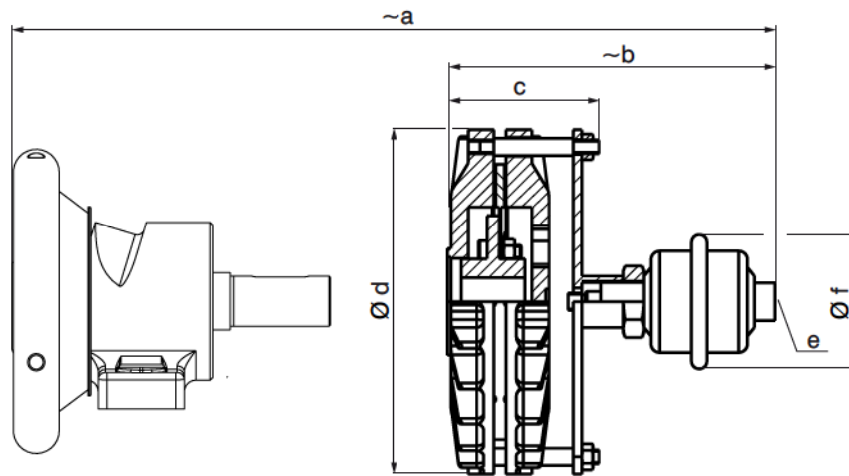

picture of chuck just symbolic

	a	b	c	d	e	f
Safety Chuck 19-25 + ESB membrane I	292	175	86	200	G 1/4	80
Safety Chuck 22-30 + ESB membrane I	298	175	86	200	G 1/4	80
Safety Chuck 30-40 + ESB membrane I	315	175	86	200	G 1/4	80
Safety Chuck 40-50 + ESB membrane I	375	185	110	235	G 1/4	80

Dimension schedule for Boschert-Chuck see chapter 2.10 - 2.40

Safety chuck with single disc brake and membrane cylinder II

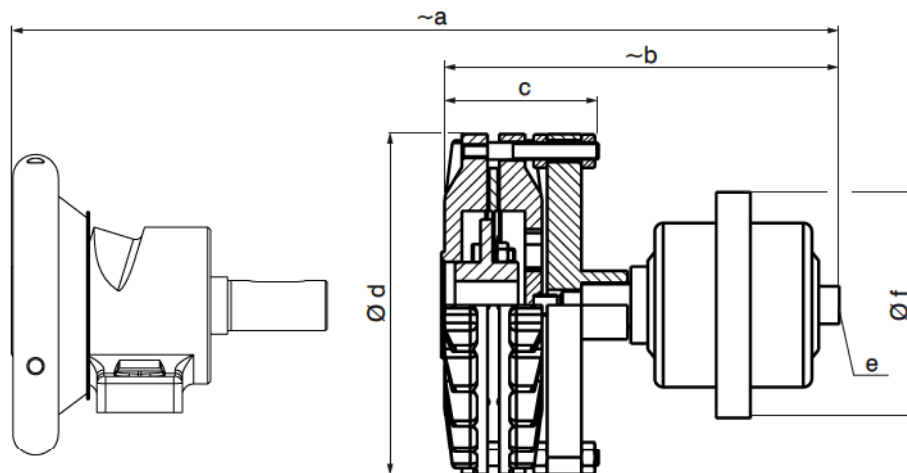

picture of chuck just symbolic

	a	b	c	d	e	f
Safety Chuck 22-30 + ESB membrane II	354	231	90	200	G 1/4	132
Safety Chuck 30-40 + ESB membrane II	371	231	90	200	G 1/4	132
Safety Chuck 40-50 + ESB membrane II	440	250	84	235	G 1/4	132

Dimension schedule for Boschert-Chuck see chapter 2.10 - 2.40

Overall dimension ESB with Sliding-, A- and P-Chuck

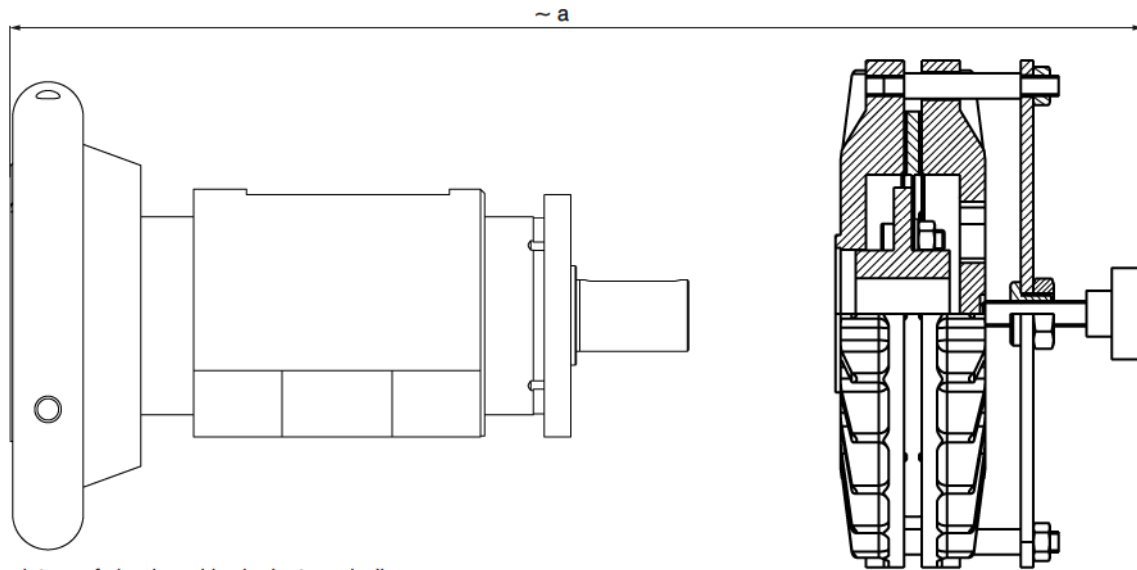

picture of chuck and brake just symbolic

overall dimension „a“
for Boschert Sliding-, A- and P-Chuck (flange- and foot mounted chuck)

	ESB				chuck dim. on page
	manual	pneumatic	membrane I	membrane II	
brake dim. on page	6.21	6.21	6.22	6.22	
Sliding-Chuck					
22-30					
50 mm adjustment	369	361	428	484	3.03 - 3.06
100 mm adjustment	469	461	528	584	3.03 - 3.06
30-40					
50 mm adjustment	371	364	426	482	3.03 - 3.06
100 mm adjustment	471	464	526	582	3.03 - 3.06
40-50					
50 mm adjustment	397	393.5	462	513	3.03 - 3.06
100 mm adjustment	497	493.5	562	613	3.03 - 3.06
A Chuck					
A40	258	250	315	371	4.21 - 4.22
A50	327	324	396	440	4.31 - 4.32
P Chuck					
P40	338	330	395	451	4.61 - 4.62
P50	393	330	455	506	4.71 - 4.72

A Chucks = A Series Pneumatic Safety Chucks
P Chucks = P Series Pneumatic Safety Chucks

ESB performance diagrams type 19-25 / 22-30 / 30-40

ESB manual

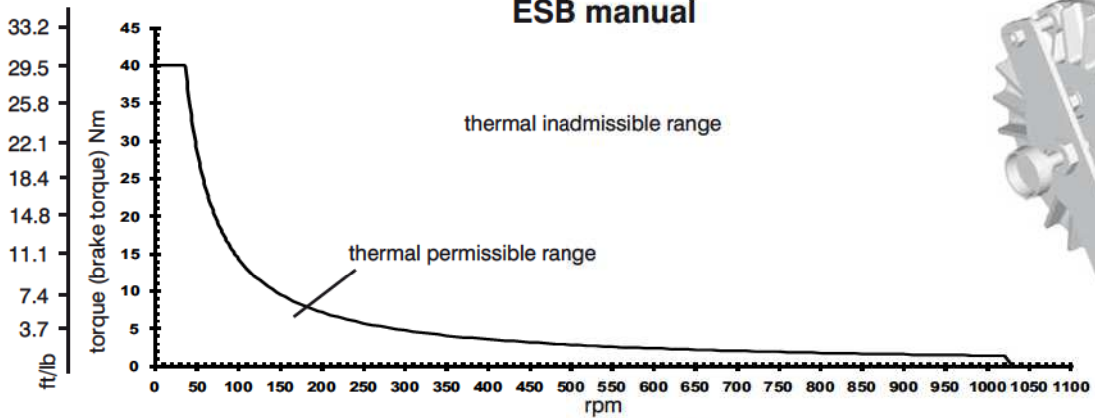

ESB pneumatic

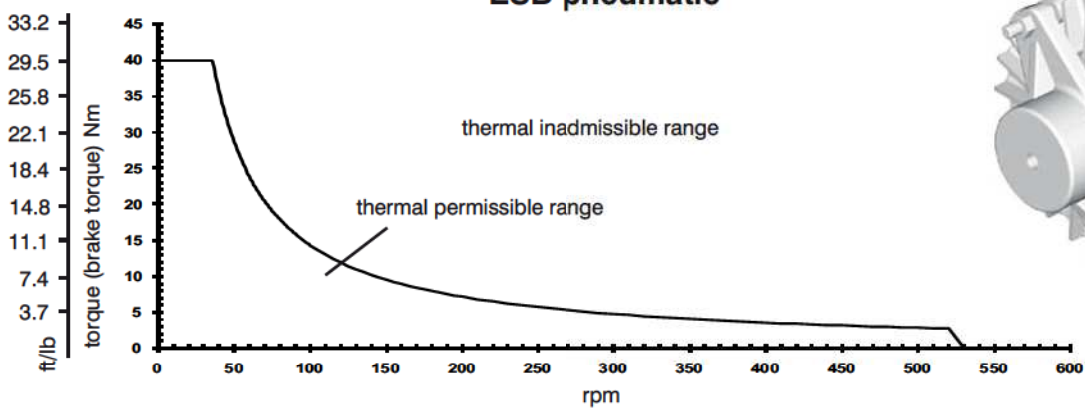

ESB membrane I

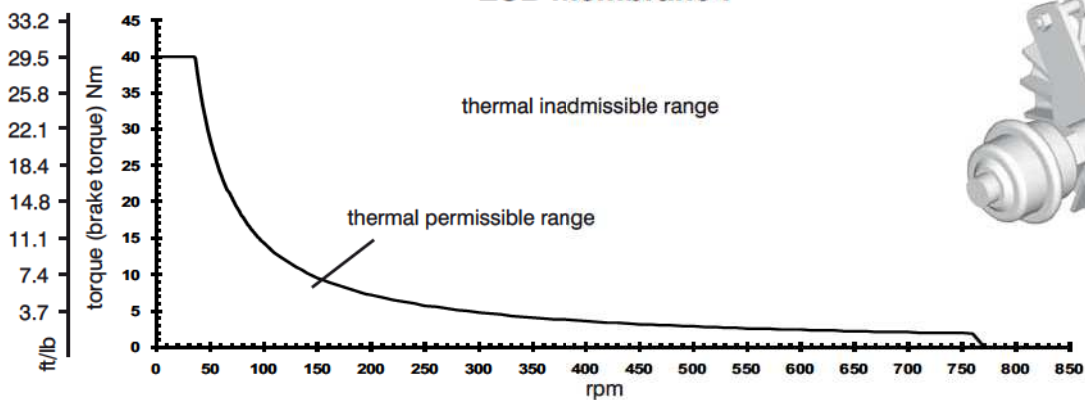

ESB membrane II

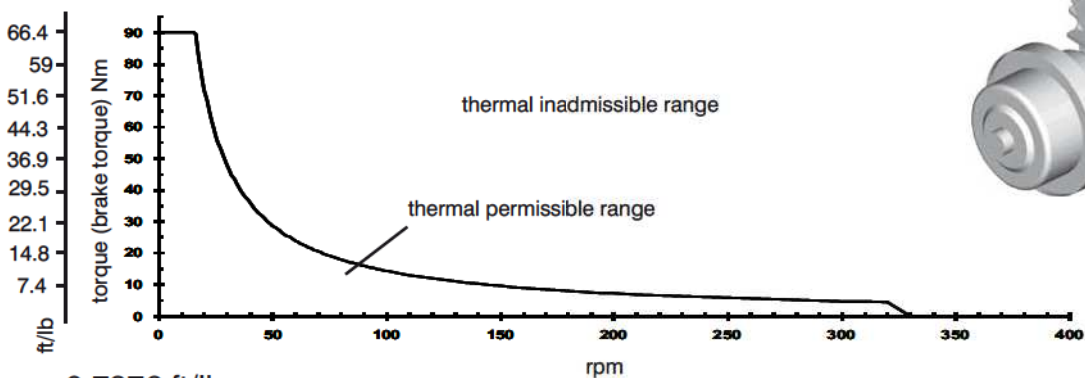

1 Nm = 0.7376 ft/lb

Mattenstrasse 1
D-79541 Loerrach-Hauingen

infokl@boschert.de
www.boschert.de

Tel.: +49 (0) 7621 / 9593 0
Fax: +49 (0) 7621 / 5518 4