

Locking assembly - Self-centering

# TLK 130

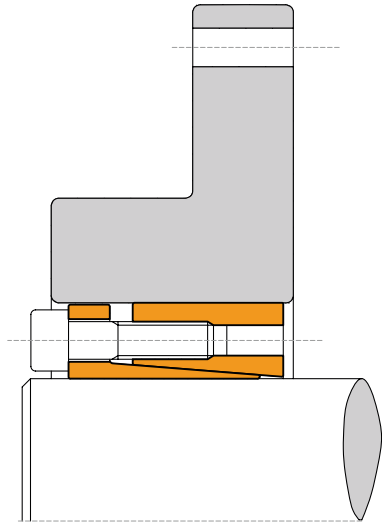

## Characteristics

- High torque
- Application economically advantageous
- Limited installation time
- Excellent shaft-hub perpendicularity

## Installation

Carefully clean the hub and shaft contact surfaces and apply a light oil film. Slide the locking assembly into the hub bore, insert the shaft and tighten gradually and regularly in crossed sequence all screws to reach the tightening torque  $M_t$  as indicated in the table.

The values  $M_t$  and  $F_{ax}$  indicated in the table are valid only in case of oil installation. Do not use any oil with **molibdenum bisulphide** or high pressure additives and not grease. Above substances notably reduce the friction coefficient.

## Dismantling

Loosen the clamping screws. Insert the screws into the dismantling threading and tighten gradually and regularly in crossed sequence until the back cone is released. If the element is to be reused, relubricate both screws and threads.

Locking assembly - Self-centering

# TLK 131

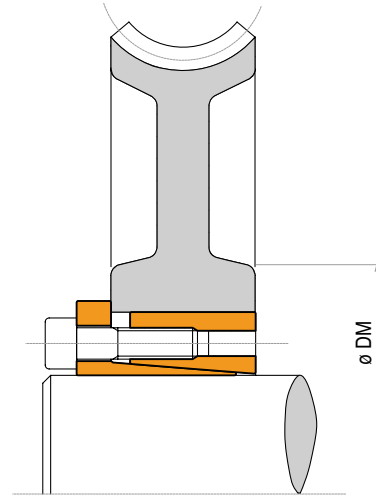

## Tolerances, surface finish

A good surface finish by the machine tool is sufficient.

Maximum allowable surface finish:

$R_t$  max 16  $\mu m$  ( $R_a$  3  $\mu m$  -  $R_z$  13  $\mu m$ )

Maximum permissible tolerances:

h8 for shaft

H8 for hub

## Axial movement

TLK 130: during screws tightening the hub has a slight axial movement with respect to the shaft.

TLK 131: during screws tightening the hub has no axial movement with respect to the shaft.

## DM hub calculation

The pressure  $P_n$  in the hub can be compared to the inside pressure on a thick hollow cylinder.

For DM calculation see page 46.

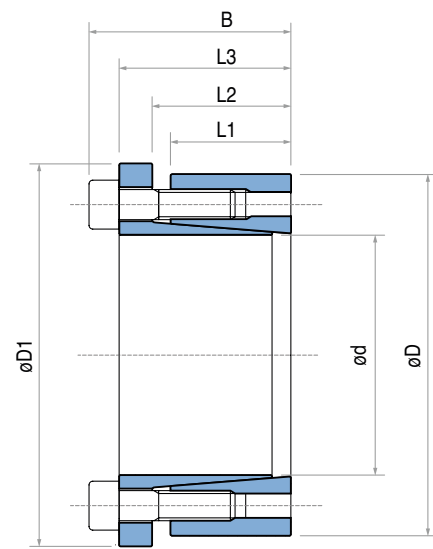
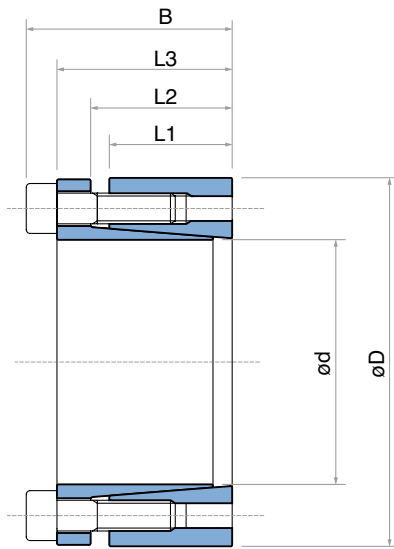

TLK 130 - TLK 131 DIMENSIONS

Dimensions						Only TLK 131	Tightening screws		TLK 130						TLK 131			
							DIN912 12.9	Tightening torque	Torque	Axial force	Surface pressures on		Weight	Torque	Axial force	Surface pressures on		Weight
											Shaft	Hub				Shaft	Hub	
d x D mm	L1 mm	L2 mm	L3 mm	B mm	D1 mm	N° x Type	M <sub>s</sub> Nm	M <sub>t</sub> Nm	F <sub>ax</sub> KN	P <sub>w</sub> N/mm <sup>2</sup>	P <sub>n</sub> N/mm <sup>2</sup>	Kg	M <sub>t</sub> Nm	F <sub>ax</sub> KN	P <sub>w</sub> N/mm <sup>2</sup>	P <sub>n</sub> N/mm <sup>2</sup>	Kg	
18 x 47	26	30	41	47	53	6 x M6	17	490	55	310	119	0,4	300	34	193	74	0,5	
19 x 47	26	30	41	47	53	6 x M6	17	510	55	294	119	0,4	320	34	183	74	0,5	
20 x 47	26	30	41	47	53	6 x M6	17	540	55	279	119	0,4	340	34	174	74	0,5	
22 x 47	26	30	41	47	53	6 x M6	17	600	55	254	119	0,4	370	34	158	74	0,5	
24 x 50	26	30	41	47	56	6 x M6	17	650	55	233	112	0,4	400	34	145	70	0,5	
25 x 50	26	30	41	47	56	6 x M6	17	680	55	223	112	0,4	420	34	139	70	0,5	
28 x 55	26	30	41	47	61	6 x M6	17	760	55	199	102	0,5	470	34	124	63	0,6	
30 x 55	26	30	41	47	61	6 x M6	17	820	55	186	102	0,5	510	34	116	63	0,6	
32 x 60	26	30	41	47	66	8 x M6	17	1160	73	233	124	0,6	720	45	145	77	0,7	
35 x 60	26	30	41	47	66	8 x M6	17	1270	73	213	124	0,5	790	45	133	77	0,6	
38 x 65	26	30	41	47	71	8 x M6	17	1380	73	196	115	0,6	860	45	122	71	0,8	
40 x 65	26	30	41	47	71	8 x M6	17	1450	73	186	115	0,6	900	45	116	71	0,6	
42 x 75	30	35	49	57	81	6 x M8	41	2120	101	213	119	1	1320	63	133	74	1,2	
45 x 75	30	35	49	57	81	6 x M8	41	2270	101	199	119	1	1410	63	124	74	1,1	
48 x 80	30	35	49	57	86	8 x M8	41	3230	135	248	149	1,1	2010	84	155	93	1,3	
50 x 80	30	35	49	57	86	8 x M8	41	3370	135	238	149	1	2100	84	149	93	1,1	
55 x 85	30	35	49	57	91	8 x M8	41	3700	135	217	140	1,1	2310	84	135	87	1,2	
60 x 90	30	35	49	57	96	8 x M8	41	4040	135	199	132	1,2	2520	84	124	83	1,3	
65 x 95	30	35	49	57	101	8 x M8	41	4380	135	183	125	1,3	2730	84	114	78	1,4	
70 x 110	40	45	59	69	117	8 x M10	83	7490	214	203	129	2,2	4670	133	126	80	2,5	
75 x 115	40	45	59	69	122	8 x M10	83	8020	214	189	123	2,5	5000	133	118	77	2,6	
80 x 120	40	45	59	69	127	8 x M10	83	8560	214	177	118	2,6	5330	133	111	74	2,8	
85 x 125	40	45	59	69	132	10 x M10	83	11370	268	209	142	2,8	7080	167	130	88	2,8	
90 x 130	40	45	59	69	137	10 x M10	83	12040	268	197	136	2,7	7500	167	123	85	3	
95 x 135	40	45	59	69	142	10 x M10	83	12700	268	187	131	2,9	7920	167	116	82	3	
100 x 145	46	52	68	80	153	8 x M12	145	15580	312	180	124	3,9	9710	194	112	77	4,5	
110 x 155	46	52	68	80	163	8 x M12	145	17140	312	163	116	4,2	10680	194	102	72	4,8	
120 x 165	46	52	68	80	173	10 x M12	145	23370	390	187	136	4,8	14570	243	117	85	5,5	
130 x 180	46	52	68	80	188	12 x M12	145	30380	467	207	150	5	18940	291	129	93	6	
140 x 190	50	57	76	90	199	10 x M14	230	37410	535	203	149	6,5	23300	333	126	93	7,5	
150 x 200	50	57	76	90	209	12 x M14	230	48100	641	227	170	7	30000	400	141	106	7,7	
160 x 210	50	57	76	90	219	12 x M14	230	51300	641	213	162	7	32000	400	133	101	8	
170 x 225	50	57	76	90	234	14 x M14	230	63600	748	234	176	8,5	39650	467	146	110	9,8	
180 x 235	50	57	76	90	244	14 x M14	230	67350	748	221	169	9	42000	467	138	105	9,8	
190 x 250	50	57	76	90	259	15 x M14	230	76150	802	224	170	10,5	47500	500	140	106	11,4	
200 x 260	50	57	76	90	269	16 x M14	230	85500	855	227	175	10,5	53300	533	141	109	11,4	
210 x 270	50	57	76	90	279	16 x M14	230	89800	855	216	168	11	56000	533	135	105	11,8	
220 x 285	64	72	94	110	294	12 x M16	355	98050	891	168	130	16,5	61150	556	105	81	17,5	
240 x 305	64	72	94	110	314	15 x M16	355	133700	1114	192	151	18	83350	695	120	94	18,9	

For larger diameter or inch series please contact us.

NOTE: it is possible to reduce the screws tightening torque down to 60% of the values indicated in above table; as a result M<sub>t</sub>, F<sub>ass</sub>, P<sub>w</sub>, P<sub>n</sub> are reduced proportionally.