

Locking assembly - Self-centering

TLK 132

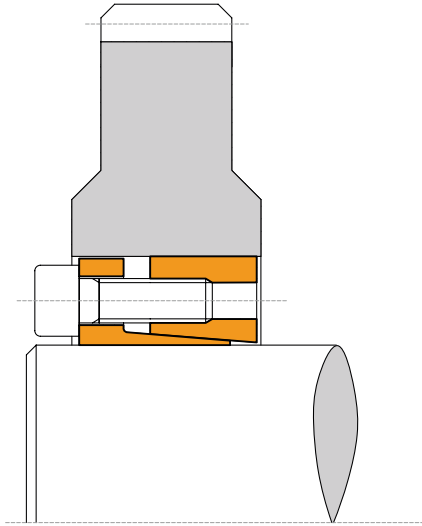

Characteristics

- Medium-high torque
- Application economically advantageous
- Limited installation time
- Interchangeable with TLK 200

Installation

Carefully clean the hub and shaft contact surfaces and apply a light oil film. Slide the locking assembly into the hub bore, insert the shaft and tighten gradually and regularly in crossed sequence all screws to reach the tightening torque M_s as indicated in the table.

The values M_t and F_{ax} indicated in the table are valid only in case of oil installation. Do not use any oil **with molybdenum bisulphide** or high pressure additives and not grease. Above substances notably reduce the friction coefficient.

Dismantling

Loosen the clamping screws. Insert the screws into the dismantling threading and tighten gradually and regularly in crossed sequence until the back cone is released. If the element is to be reused, relubricate both screws and threads.

Locking assembly - Self-centering

TLK 133

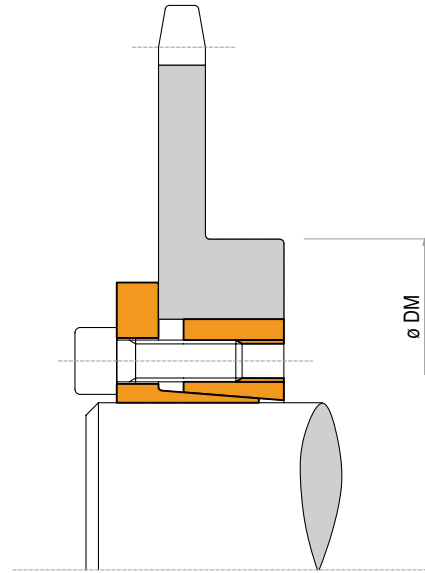

Tolerances, surface finish

A good surface finish by the machine tool is sufficient.
Maximum allowable surface finish:
 R_t max 16 μm (R_a 3 μm - R_z 13 μm)

Maximum permissible tolerances:

h8 for shaft

H8 for hub

Axial movement

TLK 132: during screws tightening the hub has a slight axial movement with respect to the shaft.

TLK 133: during screws tightening the hub has no axial movement with respect to the shaft.

DM hub calculation

The pressure P_n in the hub can be compared to the inside pressure on a thick hollow cylinder.

For DM calculation see page 46.

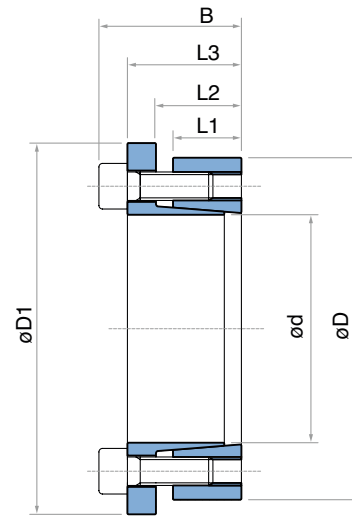
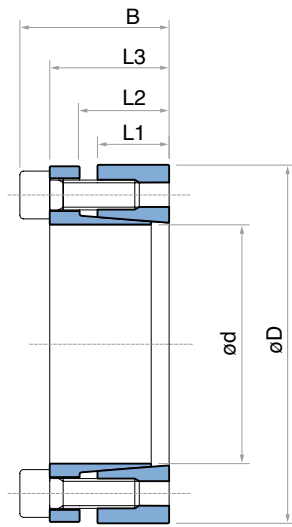

TLK 132 - TLK 133 DIMENSIONS

Dimensions					Only TLK 133	Tightening screws		TLK 132					TLK 133					
						DIN912 12.9	Tightening torque	Torque	Axial force	Surface pressures on		Weight	Torque	Axial force	Surface pressures on		Weight	
d x D mm	L1 mm	L2 mm	L3 mm	B mm	D1 mm	N° x Type	M _s (Nm) TLK 132	M _s (Nm) TLK 133	M _t Nm	F _{ax} KN	P _w N/mm ²				P _n N/mm ²	Kg		M _t Nm
18 x 47	17	22	28	34	53	5 x M6	14	17	330	38	326	125	0,35	250	28	246	94	0,3
19 x 47	17	22	28	34	53	5 x M6	14	17	350	38	308	125	0,3	270	28	233	94	0,3
20 x 47	17	22	28	34	53	6 x M6	14	17	450	45	352	150	0,3	340	34	266	113	0,3
22 x 47	17	22	28	34	53	6 x M6	14	17	490	45	320	150	0,3	370	34	242	113	0,3
24 x 50	17	22	28	34	56	6 x M6	14	17	540	45	293	141	0,3	400	34	222	106	0,3
25 x 50	17	22	28	34	56	6 x M6	14	17	560	45	281	141	0,3	420	34	213	106	0,3
28 x 55	17	22	28	34	61	6 x M6	14	17	630	45	251	128	0,4	470	34	190	97	0,4
30 x 55	17	22	28	34	61	6 x M6	14	17	670	45	234	128	0,3	510	34	177	97	0,4
32 x 60	17	22	28	34	67	8 x M6	14	17	960	60	293	156	0,4	720	45	222	118	0,4
35 x 60	17	22	28	34	67	8 x M6	14	17	1050	60	268	156	0,4	790	45	203	118	0,4
38 x 65	17	22	28	34	72	8 x M6	14	17	1140	60	247	144	0,4	860	45	187	109	0,5
40 x 65	17	22	28	34	72	8 x M6	14	17	1200	60	234	144	0,4	900	45	177	109	0,5
42 x 75	20	25	33	41	82	8 x M8	35	41	2410	115	363	204	0,8	1760	84	265	149	0,8
45 x 75	20	25	33	41	82	8 x M8	35	41	2580	115	339	204	0,6	1890	84	248	149	0,7
48 x 80	20	25	33	41	87	8 x M8	35	41	2760	115	318	191	0,8	2010	84	232	139	0,8
50 x 80	20	25	33	41	87	8 x M8	35	41	2870	115	305	191	0,8	2100	84	223	139	0,8
55 x 85	20	25	33	41	92	8 x M8	35	41	3160	115	278	180	0,8	2310	84	203	131	0,9
60 x 90	20	25	33	41	97	8 x M8	35	41	3450	115	254	170	0,8	2520	84	186	124	0,9
65 x 95	20	25	33	41	102	9 x M8	35	41	4200	129	264	181	0,9	3070	95	193	132	1
70 x 110	24	30	40	50	117	8 x M10	70	83	6300	181	285	181	1,8	4670	133	211	134	1,9
75 x 115	24	30	40	50	122	8 x M10	70	83	6750	181	266	173	1,8	5000	133	197	128	2
80 x 120	24	30	40	50	127	8 x M10	70	83	7200	181	249	166	1,8	5330	133	184	123	2
85 x 125	24	30	40	50	132	10 x M10	70	83	9600	226	293	200	2	7080	167	217	147	2
90 x 130	24	30	40	50	137	10 x M10	70	83	10150	226	277	192	2,1	7500	167	205	142	2,2
95 x 135	24	30	40	50	142	10 x M10	70	83	10700	226	263	185	2,1	7920	167	194	137	2,3
100 x 145	26	32	44	56	152	8 x M12	125	145	13450	269	274	189	2,8	9710	194	198	137	3
110 x 155	26	32	44	56	162	8 x M12	125	145	14750	269	249	177	3	10700	194	180	128	3,2
120 x 165	26	32	44	56	172	9 x M12	125	145	18150	302	257	187	3,2	13100	219	186	135	3,4
130 x 180	34	40	54	66	187	12 x M12	125	145	26200	403	242	175	4,8	18950	291	175	126	5,2
140 x 190	34	40	54	68	197	9 x M14	190	230	27800	397	221	163	5,2	21000	300	167	123	5,4
150 x 200	34	40	54	68	207	10 x M14	190	230	33100	442	230	172	5,4	25000	333	173	130	5,7
160 x 210	34	40	54	68	217	12 x M14	190	230	42400	530	258	197	5,7	32000	400	195	149	6
170 x 225	44	50	64	78	232	12 x M14	190	230	45050	530	188	142	8	34000	400	142	107	8,3
180 x 235	44	50	64	78	242	12 x M14	190	230	47700	530	177	136	8,3	36000	400	134	103	8,8
190 x 250	44	50	64	78	257	15 x M14	190	230	62900	662	210	160	9,6	47500	500	159	121	10
200 x 260	44	50	64	78	267	15 x M14	190	230	66250	662	200	154	10	50000	500	151	116	10,5

For larger diameter or inch series please contact us.

NOTE: it is possible to reduce the screws tightening torque down to 60% of the values indicated in above table; as a result M_t, F_{ass}, P_w, P_n are reduced proportionally.