

Locking assembly - Not self-centering

## TLK 300

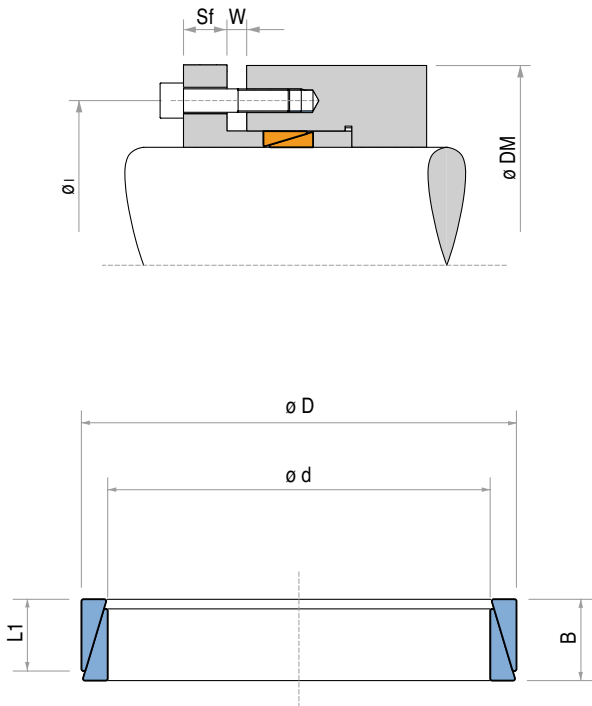

## TLK 300 DIMENSIONS

dg	DIN912			C=0,140		
	Pv in N			M <sub>s</sub> in Nm		
	8.8	10.9	12.9	8.8	10.9	12.9
M4	3900	5450	6550	2,9	4,1	4,9
M5	6350	8950	10700	6	8,5	10
M6	9000	12600	15100	10	14	17
[M7]	13200	18500	22200	16	23	28
M8	16500	23200	27900	25	35	41
[M9]	22000	30900	37100	36	51	61
M10	26200	36900	44300	49	69	83
M12	38300	54000	64500	86	120	145
M14	52500	74000	88500	135	190	230
M16	73000	102000	123000	210	295	355
M18	88000	124000	148000	290	405	485
M20	114000	160000	192000	410	580	690
M22	141000	199000	239000	550	780	930
M24	164000	230000	276000	710	1000	1200
M27	215000	302000	363000	1050	1500	1800
M30	262000	368000	442000	1450	2000	2400

$$P_a = N^{\circ} \text{ of screws} \cdot P_v$$

$$P_t = \text{see page 25}$$

$$M_t \text{ transmissible} = \frac{P_a - P_t}{0,54} \cdot 0,12 \cdot \frac{d}{2000}$$

Screws center distance  $l = D + 12 + dg$  (screws fixed on the hub) Flange thickness  $S_f = dg \cdot 1,3$  (screws quality 8.8)  
 Screws center distance  $l = d - 12 - dg$  (screws fixed on the shaft) Flange thickness  $S_f = dg \cdot 1,8$  (screws quality 12.9)

Note: On request the type TLK 300 can be supplied also with split rings: therefore the transmissible torque  $M_t$  increases. Please contact our technical department.

## Characteristics

- Medium low torque
- Restricted radial encumbrance
- Limited installation time
- Application economically advantageous

## Installation

Carefully clean the hub and shaft contact surfaces and apply a light oil film. Slide the locking elements into the hub bore, insert the shaft and tighten gradually and regularly in crossed sequence all screws to reach the tightening torque  $M_s$  as indicated in the table. The values  $M_t$  and  $F_{ax}$  indicated in the table are valid only in case of oil installation. Do not use any oil with molybdenum bisulphide or high pressure additives and not grease. Above substances notably reduce the friction coefficient.

## Dismantling

By loosening all tightening screws the locking elements are released and the clamping is free. However in case of difficulties slightly hammer the hub.

## Tolerances, surface finish

A good surface finish by the machine tool is sufficient.

Maximum allowable surface finish:

$R_t \text{ max } 6 \mu\text{m}$  ( $R_a \text{ } 1 \mu\text{m}$  -  $R_z \text{ } 5 \mu\text{m}$ )

Maximum permissible tolerances:

shaft h6 - hub H7 (up to 40mm d. diameter)

shaft h8 - hub H8 (over 42mm d. diameter)

 $M_t$  transmissible

Nr. 1 TLK 300  $M_t = M_t \text{ cat.}$

Nr. 2 TLK 300  $M_t = M_t \text{ cat.} \cdot 1,55$

Nr. 3 TLK 300  $M_t = M_t \text{ cat.} \cdot 1,85$

Nr. 4 TLK 300  $M_t = M_t \text{ cat.} \cdot 2,02$

## DM hub calculation

The pressure  $P_n$  in the hub can be compared to the inside pressure on a thick hollow cylinder.

For DM calculation see page 46.

## TLK 300 DIMENSIONS

Dimensions			Pre-load force	Total force	Torque	Axial force	Distance W before tightening				Spacer diameter		Surface pressures on		Weight
											Inside	Outside	Shaft	Hub	
d x D mm	B mm	L1 mm	Pt N	Pa N	M <sub>t</sub> Nm	F <sub>ax</sub> KN	1 mm	2 mm	3 mm	4 mm	d1 mm	D1 mm	p <sub>w</sub> N/mm <sup>2</sup>	P <sub>n</sub> N/mm <sup>2</sup>	Kg
6 x 9	4,5	3,7	-	3800	2	0,84	2,5	2,5	3	4	6,1	8,9	115	75	0,002
7 x 10	4,5	3,7	-	3900	3	0,86	2,5	2,5	3	4	7,1	9,9	105	70	0,002
8 x 11	4,5	3,7	-	5300	5	1,17	2,5	2,5	3	4	8,1	10,9	120	90	0,002
9 x 12	4,5	3,7	7650	15600	8	1,76	2,5	2,5	3	4	9,1	11,9	140	105	0,000
10 x 13	4,5	3,7	7000	15600	10	1,91	2,5	2,5	3	4	10,1	12,9	135	105	0,002
12 x 15	4,5	3,7	7000	15600	11	1,91	2,5	2,5	3	4	12,1	14,9	115	90	0,002
13 x 16	4,5	3,7	6500	15600	13	2,02	2,5	2,5	3	4	13,1	15,9	110	90	0,000
14 x 18	6,3	5,3	11000	25400	22	3,18	3,5	3,5	4,5	5,5	14,1	17,9	115	90	0,005
15 x 19	6,3	5,3	10800	25400	24	3,24	3,5	3,5	4,5	5,5	15,1	18,9	110	85	0,005
16 x 20	6,3	5,3	10000	25400	27	3,42	3,5	3,5	4,5	5,5	16,1	19,9	105	85	0,006
17 x 21	6,3	5,3	9600	25400	30	3,51	3,5	3,5	4,5	5,5	17,1	20,9	105	85	0,006
18 x 22	6,3	5,3	9150	25400	32	3,61	3,5	3,5	4,5	5,5	18,1	21,9	100	80	0,007
19 x 24	6,3	5,3	12500	36000	49	5,22	3,5	3,5	4,5	5,5	19,2	23,8	140	110	0,007
20 x 25	6,3	5,3	12000	36000	53	5,33	3,5	3,5	4,5	5,5	20,2	24,8	135	105	0,009
22 x 26	6,3	5,3	9000	36000	66	6	3,5	3,5	4,5	5,5	22,2	25,8	135	115	0,007
24 x 28	6,3	5,3	8400	36000	73	6,13	3,5	3,5	4,5	5,5	24,2	27,8	130	110	0,008
25 x 30	6,3	5,3	10000	36000	72	5,77	3,5	3,5	4,5	5,5	25,2	29,8	115	95	0,009
28 x 32	6,3	5,3	7500	36000	88	6,33	3,5	3,5	4,5	5,5	28,2	31,8	115	100	0,010
30 x 35	6,3	5,3	8600	36000	91	6,08	3,5	3,5	4,5	5,5	30,2	34,8	100	85	0,011
32 x 36	6,3	5,3	7900	45000	131	8,24	3,5	3,5	4,5	5,5	32,2	35,8	130	115	0,011
35 x 40	7	6	10000	54000	171	9,77	3,5	3,5	4,5	5,5	35,2	39,8	125	110	0,016
36 x 42	7	6	11700	54000	169	9,39	3,5	3,5	4,5	5,5	36,2	41,8	115	100	0,019
38 x 44	7	6	11000	54000	181	9,55	3,5	3,5	4,5	5,5	38,2	43,8	110	95	0,021
40 x 45	8	6,6	13900	66000	231	11,57	3,5	4,5	5,5	6,5	40,2	44,8	115	105	0,021
42 x 48	8	6,6	15550	66000	235	11,22	3,5	4,5	5,5	6,5	42,2	47,8	110	95	0,026
45 x 52	10	8,6	28300	99000	353	15,71	3,5	4,5	5,5	6,5	45,2	51,8	105	95	0,045
48 x 55	10	8,6	24700	132000	572	23,84	3,5	4,5	5,5	6,5	48,2	54,8	155	135	0,043
50 x 57	10	8,6	23600	132000	602	24,08	3,5	4,5	5,5	6,5	50,2	56,8	150	130	0,045
55 x 62	10	8,6	21700	132000	670	24,35	3,5	4,5	5,5	6,5	55,2	61,8	140	125	0,049
56 x 64	12	10,4	29500	157200	790	28,2	3,5	4,5	5,5	7	56,2	63,8	130	115	0,070
60 x 68	12	10,4	27500	157200	860	28,6	3,5	4,5	5,5	7	60,2	67,8	125	110	0,070
63 x 71	12	10,4	26500	157200	910	28,8	3,5	4,5	5,5	7	63,2	70,8	120	105	0,080
65 x 73	12	10,4	25500	157200	950	29,2	3,5	4,5	5,5	7	65,2	72,8	115	100	0,090
70 x 79	14	12,2	31000	209600	1380	39,4	3,5	5	6,5	7,5	70,3	78,7	125	110	0,115
71 x 80	14	12,2	31000	209600	1400	39,4	3,5	5	6,5	7,5	71,3	79,7	120	110	0,110
75 x 84	14	12,2	34700	209600	1450	38,6	3,5	5	6,5	7,5	75,3	83,7	115	100	0,120
80 x 91	17	15	48000	290000	2200	55	4	6	6,5	8	80,3	90,7	125	105	0,210
85 x 96	17	15	45500	305000	2400	56,4	4	6	6,5	8	85,3	95,7	120	105	0,210
90 x 101	17	15	43600	320000	2730	60,5	4	6	6,5	8	90,3	100,7	120	105	0,220
95 x 106	17	15	41300	330000	3050	64,2	4	6	6,5	8	95,3	105,7	120	110	0,230
100 x 114	21	18,7	61000	445000	4200	84	5	6	7	9	100,3	113,7	120	105	0,390
110 x 124	21	18,7	66000	485000	5150	93,6	5	6	7	9	110,3	123,7	120	105	0,420
120 x 134	21	18,7	60300	510000	6050	100,8	5	6	7	9	120,2	133,7	120	105	0,460
130 x 148	28	25,3	96300	765000	9600	147,6	5	7	9	11	130,4	147,6	120	105	0,860
140 x 158	28	25,3	89000	800500	11000	158,5	6	7	9	11	140,4	157,6	120	105	0,960
150 x 168	28	25,3	85000	860000	12900	172	6	7	8	11	150,4	167,6	120	105	1,000
160 x 178	28	25,3	78600	900000	14600	182,5	6	7	9	11	160,4	177,6	120	110	1,000
170 x 191	33	30	117400	1160000	19500	229	7	9	10	12	170,5	190,5	120	105	1,540
180 x 201	33	30	111300	1200000	21300	236	7	9	10	12	180,5	200,5	120	105	1,500
190 x 211	33	30	105000	1260000	24200	255	7	9	10	12	190,5	210,5	120	110	1,800
200 x 224	38	34,8	134200	1550000	31000	310	7	8	11	13	200,6	223,4	120	105	2,400
210 x 234	38	34,8	127200	1610000	35000	333	7	9	11	13	210,6	233,4	120	110	2,500
220 x 244	38	34,8	122100	1690000	38000	345	7	9	11	13	220,6	243,4	120	110	2,600
230 x 257	43	39,5	164500	2000000	47000	408	7	10	12	14	230,6	256,4	120	105	3,400
240 x 267	43	39,5	157400	2250000	51000	425	7	10	12	14	240,6	266,4	120	110	3,800
250 x 280	48	44	190000	2060000	52000	415	7	10	13	16	250,8	279,2	100	89	4,800
260 x 290	48	44	182000	2132000	56500	435	7	10	13	16	260,8	289,2	100	89	4,900
270 x 300	48	44	177000	2207000	61000	450	7	10	13	16	270,8	299,2	100	89	5,000
280 x 313	53	49	206000	2536000	72500	520	7	11	14	17	280,8	312,2	100	89	6,400
290 x 323	53	49	222000	2632000	77500	535	7	11	14	17	290,8	322,2	100	89	6,500
300 x 333	53	49	214000	2704000	83000	555	7	11	14	17	300,8	332,2	100	89	6,800
320 x 360	65	59	292000	3492000	114000	710	10	15	20	25	321,0	359,0	100	89	11,000
340 x 380	65	59	272000	3672000	128500	755	10	15	20	25	341,0	379,0	100	89	11,500
360 x 400	65	59	258000	3858000	144000	800	10	15	20	25	361,0	399,0	100	90	12,300
380 x 420	65	59	269000	4069000	160500	845	10	15	20	25	381,0	419,0	100	90	13,000
400 x 440	65	59	256000	4256000	178000	890	10	15	20	25	401,0	439,0	100	90	13,700
420 x 460	65	59	244000	4444000	196000	935	10	15	20	25	421,0	459,0	100	90	14,100
440 x 480	65	59	234000	4633000	215000	980	10	15	20	25	441,0	479,0	100	90	14,800
460 x 500	65	59	224000	4824000	235000	1020	10	15	20	25	461,0	499,0	100	91	15,500
480 x 520	65	59	239000	5039000	256000	1070	10	15	20	25	481,0	519,0	100	91	16,000
500 x 540	65	59	229000	5229000	278000	1110	10	15	20	25	501,0	539,0	100	91	16,700
520 x 570	80	73	338000	6788000	372000	1430	12	18	24	30	521,0	569,0	100	91	27,000
540 x 590	80	73	326000	7026000	400000	1480	12	18	24	30	541,0	589,0	100	91	28,000

For larger diameter or inch series please contact us.