

## Clamping Elements

### On-the-spot clamping and stopping in emergencies and other situations

Clamping elements from the LOCKED series also serve the purpose of safety. These ACE products clamp and decelerate loads and are suitable for perfectly controlled holding, both linear and rotary, in all processes.

Alongside ACE LOCKED solutions for conventional rail, rod or rotation clamping, special clamps with safety function for Z-axes, which reliably help secure axes with a gravitational load, are available in the LOCKED LZ-P series. The latter solution is available for both pneumatic operation and as an electric version. Whether Z-axes, linear guide, rod or rotation clamping, the choice is (typical of ACE) as large as the performance capacity of the products, which are compatible with the solutions of all standard manufacturers.

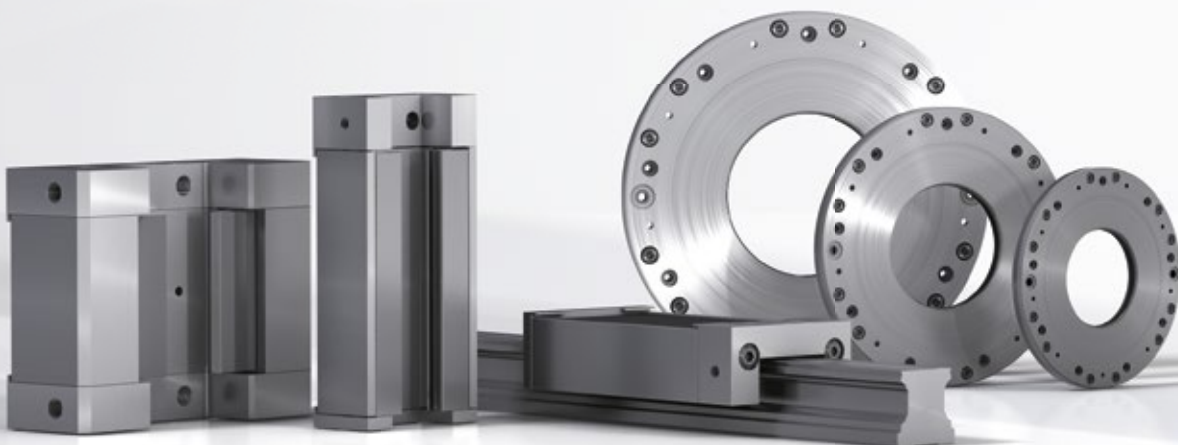

**LOCKED by ACE. After all, safe is safe.**

**Increased process reliability**

**Available as clamping and emergency stop brakes**

**Very short stop distances**

**Very high clamping forces**

**Compact designs**

**Ideal for all standard sizes**



## Rail Clamping

### For safe deceleration of rail-guided construction elements

Safe deceleration of a mass that is traversed with the help of a rail and guide rail and track carriage combination must be complied with and not only for safety reasons; reliable clamps in the production processes are also becoming increasingly important.

Both features can be taken care of by the clamping elements from ACE. All clamping elements work with the patented spring steel plate system.

This system achieves braking and clamping forces of up to 10,000 N. The clamping elements are always individually adapted to the used linear guide. They are available for all rail sizes and profiles for all renowned manufacturers.

### Function of clamping elements LOCKED PL/SL/PLK/SLK

All process and safety clamps work with the reinforced spring steel plate system.

Compressed air is introduced between the two spring plates, which are connected with a surrounding rubber coating.

If pressure is applied, the clamping element can freely move; if the clamping element is vented clamping to the guide rail follows.

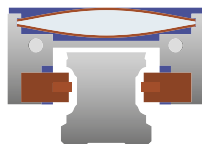

Clamping element vented

#### Released

The chamber filled with compressed air between the spring steel plates relaxes and thus releases the clamping/brake pads from the rail. The clamping element is now free to move.

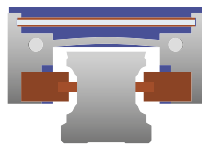

Clamping element vented

#### Engaged

The clamping force of the mechanically pre-stressed spring steel plates is transferred to the clamping/brake pads as holding force. The clamping element is clamped on the guide rail.

### Slot dimensions between braking and clamping linings and linear guide rail

The internal dimension "I" between the linings of every LOCKED rail clamping is ground to an exact value.

This is always 0.01 to 0.03 mm greater than the upper limit J max. of the respective linear guide rail (see drawing), resulting from the manufacturer's directives.

The maximum holding force results at J max. and, in the most unfavorable case, holding force losses up to 30 % can occur (see table).

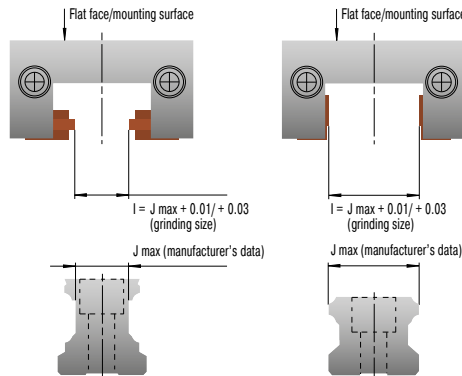

Air Gap Lining/Linear Guide Rail mm	Loss in Holding Force %
0.01	5
0.03	10
0.05	20
0.07	30

### Different brake pads for PL/PLK and for SL/SLK

The process clamps and safety clamps are available completely identical in their structure.

They differ only in the clamping and brake pads material.



Clamping

#### Position Clamping

The types of the LOCKED series PL and PLK are designed for clamping directly on the linear guide. The clamping linings are produced from tool steel and offer 100 % clamping force, even in the case of lubricated rails.



Braking

#### Position Clamping and Emergency Stop Braking

With the typical SL, SLK, low-wear sinter graphite linings are employed. These enable both a position clamping, as well as emergency stop braking on the linear guide. In case of lubricated rails, a stopping force of 60 % of the nominal stopping force should be considered.

## Rod Clamping

### The modular solution for exact holding at certain positions

Safe and reliable stopping at a position or an operating state is an important part of many production processes. This task can be performed by the clamping elements from ACE. If clamping on a rod is required, the clamping elements of the PN and PRK families are the right choice.

Safe and reliable stopping at a position or an operating state is an important part of many production processes. This task can be performed by the clamping elements from ACE. If clamping on a rod is required, the clamping elements of the PN and PRK families are the right choice.

The PN and PRK rod clamps can absorb both axial and rotary forces.

### Function of clamping elements LOCKED PN and PRK

Consisting of a deck plate, one to three clamping units and a base plate, all rod clamps work with the reinforced spring steel plate system.

Through that, both axial and rotary forces can be absorbed.

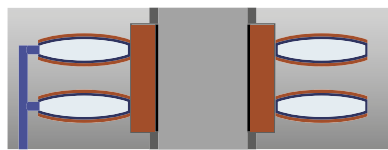

Clamping element is released

#### Released

The membrane filled with compressed air relaxes the spring steel plate system and releases the clamping sleeve.

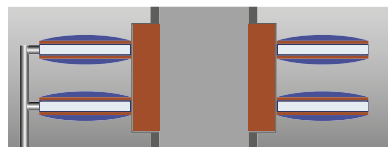

Clamping element is engaged

#### Engaged

The clamping force of the mechanically pre-stressed spring steel plates system is transferred as a holding force into the clamping sleeve. The rod or shaft is engaged.

### Intelligent component system solution

By connecting up to three clamping units between the base and deck plates, it is possible to easily increase the clamping force.

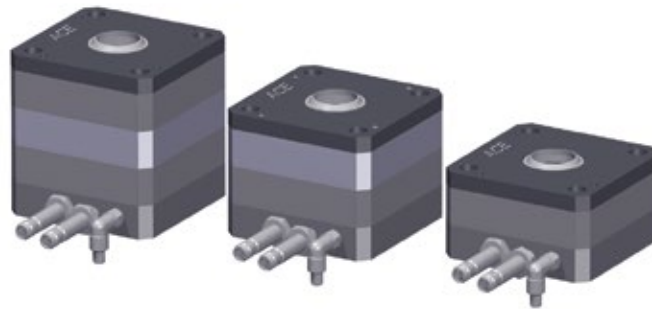

Modular construction

### Component tolerances for LOCKED PN and PRK

Design-related, the addition of the individual component tolerances leads to an elastic axial tolerance allowance. This axial tolerance allowance can be up to 500 µm in the clamped status, according to implementation!

The axis/shaft/rod must be machined with at least h9-fit (or better) above h5. Deviations from the prescribed tolerance can lead to reduction of the stopping force, or functional failure.



Rod clamping

## Rotational Clamping

### The reliable protection against twisting

Reliable holding and securing against a rotation of a position are important elements in many production processes.

This task can be performed by means of the clamping elements of the Locked R family. The rotational clamps can, thanks to the patented spring steel plate system, transfer holding torques of up to 4,680 Nm to the shaft.

The spring accumulator can immediately clamp the axis during a power failure.

### Function of clamping elements LOCKED R

The reinforced spring steel plate system transfers holding torques in the shortest possible time.



Clamping element is released

#### Released

The membrane filled with compressed air relaxes the spring steel plate system and releases the clamping ring. The shaft is free to move.



Clamping element is engaged

#### Engaged

The clamping force of the membrane/spring steel plates systems is transferred to the holding force of the clamping ring. The shaft is clamped.

### Function of clamping elements LOCKED Z with additional air

If higher holding torques are required, the rotational clamps with an additional air function are used.

With the same size, significantly higher holding torques are achieved.



Increased clamping force with additional air

#### Engaged with additional air

By filling the outer membrane chamber with additional compressed air (4 or 6 bar), there is the possibility to increase the clamping force. The clamping element is engaged in this condition.

## Clamping Elements



### LOCKED PL

Page 274

Process Clamping for Rail Systems

**High clamping power for all rail profiles**

 Tool machines, Transport systems, Feeder installations,  
Positioning tables

### LOCKED PLK

Page 276

Process Clamping for Rail Systems, Compact

**High clamping power for all compact design rail profiles**

 Tool machines, Transport systems, Feeder installations,  
Positioning tables

### LOCKED SL

Page 278

Safety Clamping for Rail Systems

**Combined clamping and braking**

 Tool machines, Transport systems, Feeder installations,  
Positioning tables

### LOCKED SLK

Page 280

Safety Clamping for Rail Systems, Compact

**Combined compact design clamping and braking**

 Tool machines, Transport systems, Feeder installations,  
Positioning tables

### LOCKED LZ-P

Page 282

Rail Clamping for Z-Axes

**Certified safety clamping**

Z-axes, Vertical conveyor systems, Jacking applications



### LOCKED PN

Page 284

Pneumatic Rod Clamping

**Rod clamping with maximum clamping force**

 Jacking systems, Light presses, Punching/stamping machines,  
Stacking units

### LOCKED PRK

Page 286

Pneumatic Rod Clamping, Compact

**Rod clamping with maximum clamping force in a compact size**

 Jacking systems, Light presses, Punching/stamping machines,  
Stacking units

### LOCKED R

Page 288

Pneumatic Rotational Clamping

**Strong holding force on the shaft**

Drive shafts, Torque motors, Conveyor systems

## LOCKED PL Clamping Elements

### High clamping power for all rail profiles

Always on the safe side: The process clamping elements from the LOCKED series PL clamp directly onto the clear area of guide rails on linear modules with forces of up to 10,000 N. They are individually adjusted to the linear guide being used and are available for all rail sizes from 20 to 65 mm and profiles from all renowned manufacturers.

This series achieves 100 % clamping force even on greased rails, due to the steel pads that are used. It offers optimum static clamping with up to 1 million cycles or up to 500 emergency braking operations. These process clamping elements also impress with their low system costs in comparison with hydraulic and electric solutions.

The various models from the LOCKED Series PL from ACE are mainly used on machine tools and customised machines.

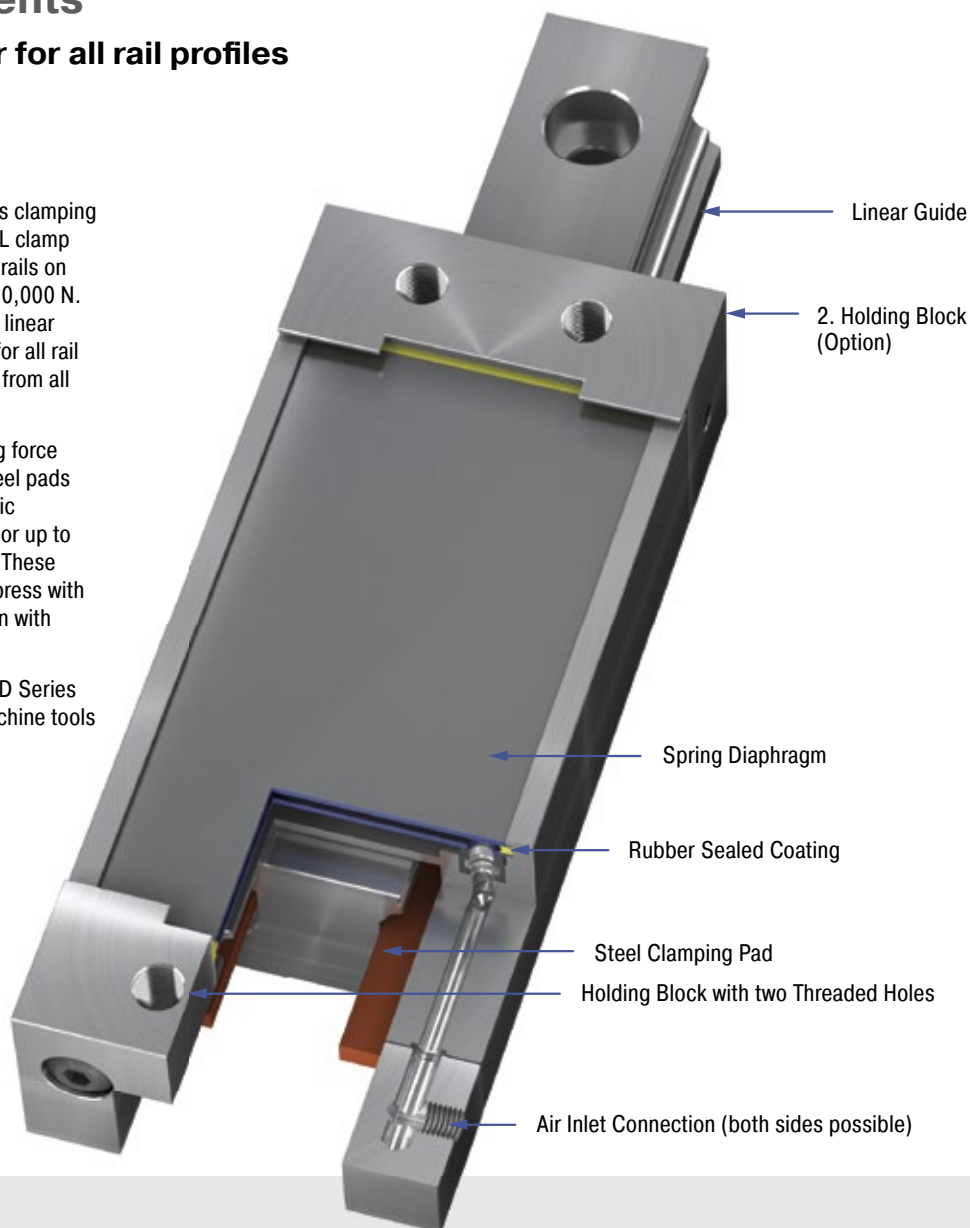

#### Technical Data

**Holding forces:** 540 N to 10,000 N

**Rail sizes:** 20 mm to 65 mm

**Clamping cycles:** 1,000,000/500. Higher values on request.

**Mounting:** In any position

**Operating pressure:** 4 bar (automotive) or 6 bar

**Material:** Outer body: Tool steel

**Pneumatic medium:** Dried, filtered air

**Operating temperature range:** 15 °C to 45 °C

**Application field:** Tool machines, Transport systems, Feeder installations, Positioning tables

**Note:** If requested installation drawings of the respective types are provided.

**On request:** Special designs on request.



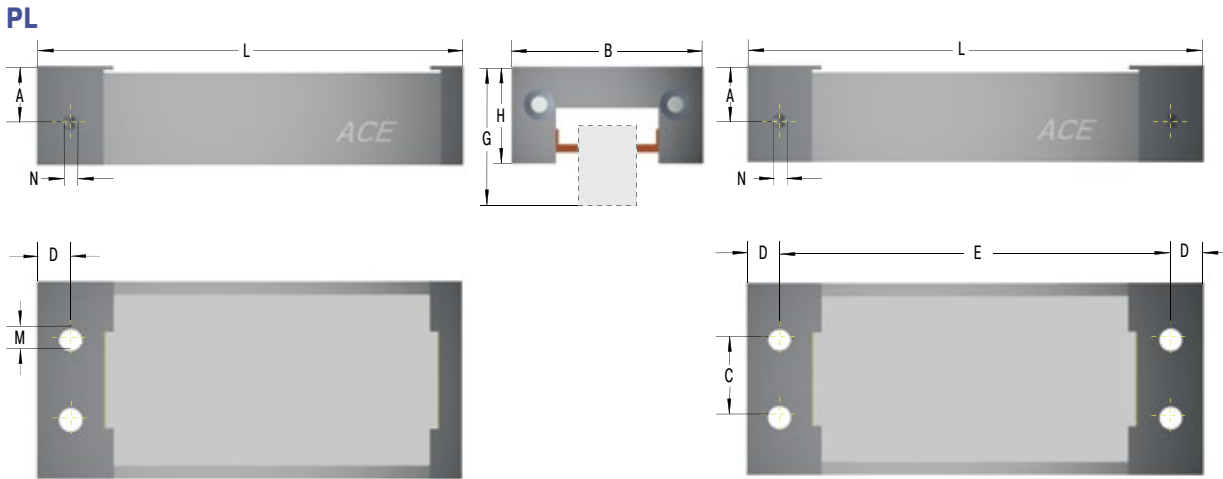

The calculation and selection of the most suitable clamping element should be carried out or be approved by ACE.

#### Complete details required when ordering

Operating pressure: 4 bar or 6 bar

#### Ordering Example

Linear Process Clamping ↑ **PL45-2-6B-X**  
 Rail Nominal Size 45 mm ↑  
 Number of Holding Blocks 2 ↑  
 6B = 6 bar Type ↑  
 4B = 4 bar Type ↑  
 Series Number assigned by ACE ↑

#### Performance and Dimensions

TYPES	Holding force N	Operating pressure bar	B mm	C mm	D mm	E mm	L mm	Low Carriage			High Carriage			M	N	Weight kg
								A mm	G mm	H mm	A mm	G mm	H mm			
PL20-1-4B	540	4	43	12	6	-	97.5	13.5	30	19.5	-	-	-	M5	M5	0.32
PL20-1-6B	900	6	43	12	6	-	97.5	13.5	30	19.5	-	-	-	M5	M5	0.32
PL25-1-4B	780	4	47	16	6	-	117.5	15.5	36	25	19.5	40	29	M6	M5	0.50
PL25-1-6B	1,200	6	47	16	6	-	117.5	15.5	36	25	19.5	40	29	M6	M5	0.50
PL30-1-4B	1,100	4	59	18	10	-	126.5	17.0	42	29.5	20.0	45	32.5	M8	M5	0.90
PL30-1-6B	1,800	6	59	18	10	-	126.5	17.0	42	29.5	20.0	45	32.5	M8	M5	0.90
PL35-1-4B	1,800	4	69	22	10	-	156.5	22.5	48	35	29.5	55	42	M10	G1/8	1.26
PL35-1-6B	2,800	6	69	22	10	-	156.5	22.5	48	35	29.5	55	42	M10	G1/8	1.26
PL45-1-4B	2,400	4	80	28	10	-	176.5	26.5	60	42	36.5	70	52	M10	G1/8	2.30
PL45-1-6B	4,000	6	80	28	10	-	176.5	26.5	60	42	36.5	70	52	M10	G1/8	2.30
PL45-2-4B	2,400	4	80	28	10	171.2	191.5	26.5	60	42	36.5	70	52	M10	G1/8	2.30
PL45-2-6B	4,000	6	80	28	10	171.2	191.5	26.5	60	42	36.5	70	52	M10	G1/8	2.30
PL55-1-4B	3,600	4	98	34	12.5	-	202.5	28.0	70	49	38.0	80	59	M10	G1/8	3.90
PL55-1-6B	6,000	6	98	34	12.5	-	202.5	28.0	70	49	38.0	80	59	M10	G1/8	3.90
PL55-2-4B	3,600	4	98	34	12.5	196.2	221.5	28.0	70	49	38.0	80	59	M10	G1/8	4.10
PL55-2-6B	6,000	6	98	34	12.5	196.2	221.5	28.0	70	49	38.0	80	59	M10	G1/8	4.10
PL65-1-4B	6,000	4	120	44	15	-	259.5	38.0	90	64	48.0	100	74	M12	G1/8	5.00
PL65-1-6B	10,000	6	120	44	15	-	259.5	38.0	90	64	48.0	100	74	M12	G1/8	5.00
PL65-2-4B	6,000	4	120	44	15	251.5	281.5	38.0	90	64	48.0	100	74	M12	G1/8	5.20
PL65-2-6B	10,000	6	120	44	15	251.5	281.5	38.0	90	64	48.0	100	74	M12	G1/8	5.20

<sup>1</sup> The holding forces as shown in the capacity chart were determined on dry rails for roller systems (STAR, INA). Different holding forces may occur for other rails.



## LOCKED PLK Clamping Elements

### High clamping power for all compact design rail profiles

Small can clamp perfectly too: The LOCKED-Series PLK clamping elements are more compact than the Series PL components. They also clamp directly onto the respective linear guide, suit all standard rail sizes from 15 to 55 mm and profiles from the known suppliers and are extremely reliable and space-saving.

Thanks to the patented spring steel plate system, the LOCKED-Series PLK achieves clamping and holding forces of up to 2,100 N with the shortest reaction times when vented. The LOCKED-Series PLK achieves 100 % clamping force due to the steel pads that are used, even on greased rails. The clamping elements represent the maximum holding forces. Whether in the 4 or 6 bar version, they are good for up to 1 million cycles or up to 500 emergency braking operations.

Representatives of the LOCKED-Series PLK from ACE are primarily used in mechanical engineering and customised machines.

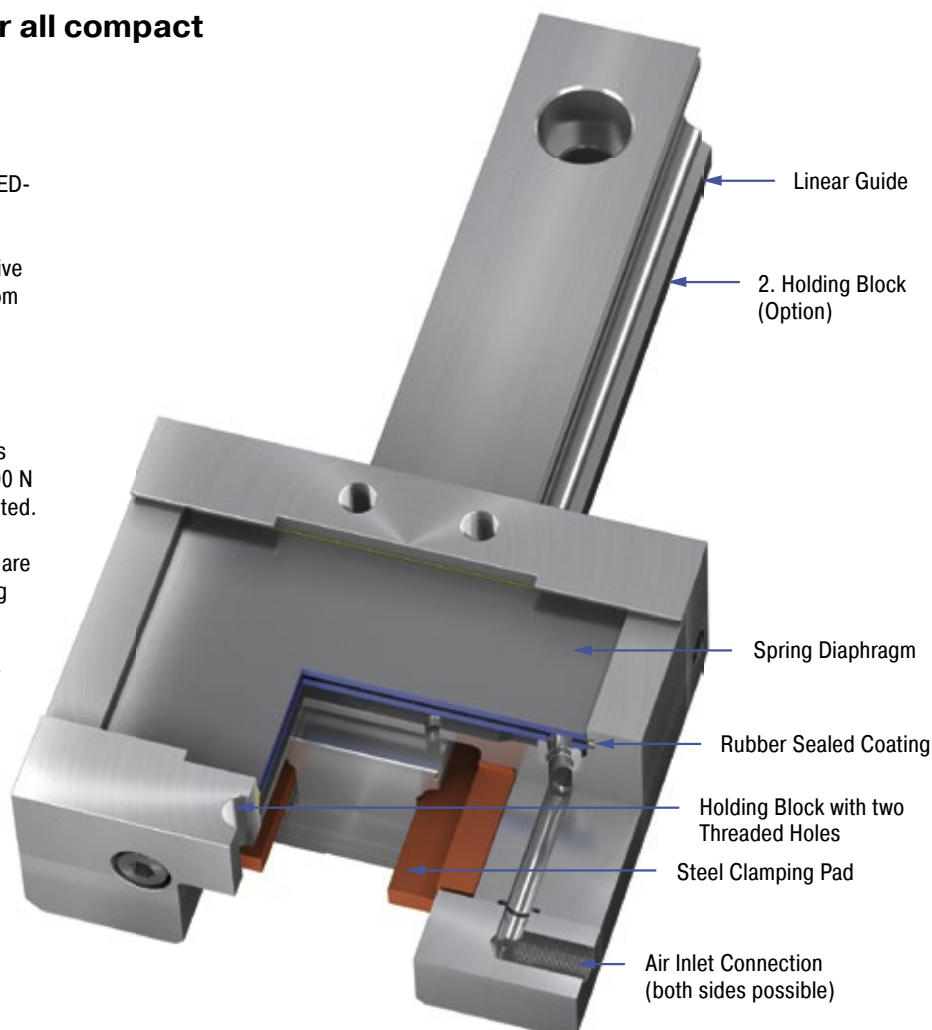

### Technical Data

**Holding forces:** 300 N to 2,100 N

**Rail sizes:** 15 mm to 55 mm

**Clamping cycles:** 1,000,000/500. Higher values on request.

**Mounting:** In any position

**Operating pressure:** 4 bar (automotive) or 6 bar

**Material:** Outer body: Tool steel

**Pneumatic medium:** Dried, filtered air

**Operating temperature range:** 15 °C to 45 °C

**Application field:** Tool machines, Transport systems, Feeder installations, Positioning tables

**Note:** If requested installation drawings of the respective types are provided.

**On request:** Special designs on request.

#### PLK

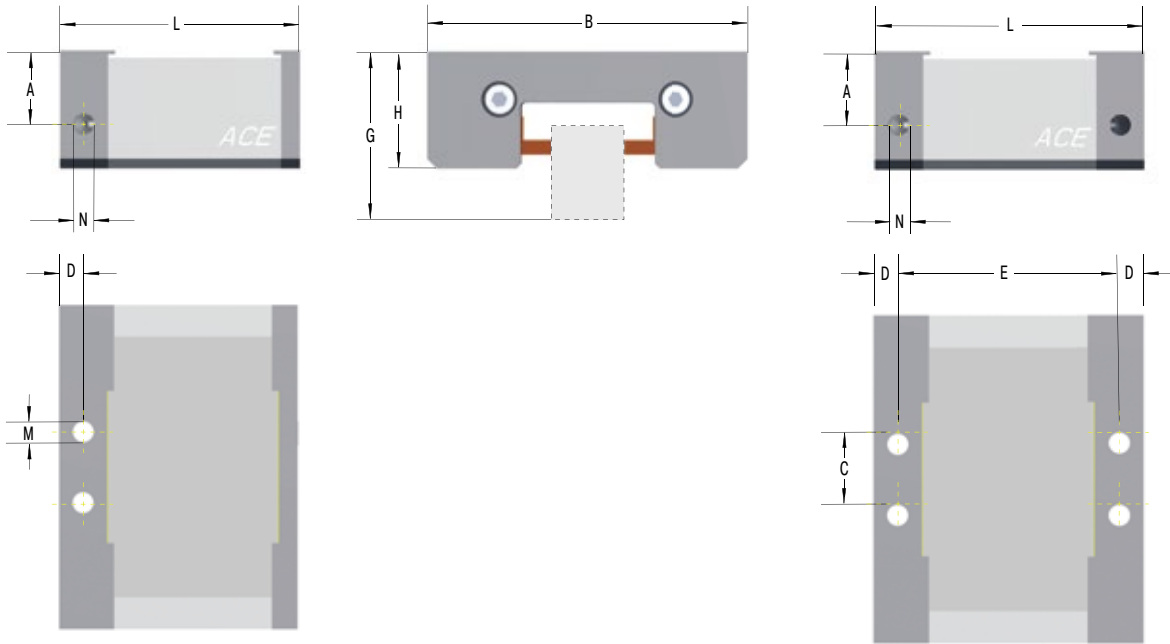

The calculation and selection of the most suitable clamping element should be carried out or be approved by ACE.

#### Complete details required when ordering

Operating pressure: 4 bar or 6 bar

#### Ordering Example

**PLK55-2-6B-X**

Linear Process Clamping Compact \_\_\_\_\_  
 Rail Nominal Size 55 mm \_\_\_\_\_  
 Number of Holding Blocks 2 \_\_\_\_\_  
 6B = 6 bar Type \_\_\_\_\_  
 4B = 4 bar Type \_\_\_\_\_  
 Series Number assigned by ACE \_\_\_\_\_

#### Performance and Dimensions

TYPES	Holding force N	Operating pressure bar	Low Carriage					High Carriage			M	N	Weight kg			
			B mm	C mm	D mm	E mm	L mm	A mm	G mm	H mm						
PLK15-1-4B	300	4	45	12	5	-	55.5	14.0	24	18	14.0	-	-	M5	M5	0.50
PLK15-1-6B	450	6	45	12	5	-	55.5	14.0	24	18	14.0	-	-	M5	M5	0.50
PLK20-1-4B	430	4	54	16	5	-	55.5	16.0	30	22	16.0	-	-	M6	M5	0.60
PLK20-1-6B	650	6	54	16	5	-	55.5	16.0	30	22	16.0	-	-	M6	M5	0.60
PLK25-1-4B	530	4	75	16	5	-	55.5	16.0	36	25.5	16.0	40	29.5	M6	M5	0.70
PLK25-1-6B	800	6	75	16	5	-	55.5	16.0	36	25.5	16.0	40	29.5	M6	M5	0.70
PLK30-1-4B	750	4	82	18	8.75	-	67	21.0	42	30	21.0	45	33	M8	M5	0.90
PLK30-1-6B	1,150	6	82	18	8.75	-	67	21.0	42	30	21.0	45	33	M8	M5	0.90
PLK35-1-4B	820	4	96	22	8.75	-	67	21.2	48	35	21.2	55	42	M10	G1/8	1.27
PLK35-1-6B	1,250	6	96	22	8.75	-	67	21.2	48	35	21.2	55	42	M10	G1/8	1.27
PLK45-1-4B	950	4	116	28	10	-	80	27.5	60	45	27.5	70	55	M10	G1/8	2.00
PLK45-1-6B	1,500	6	116	28	10	-	80	27.5	60	45	27.5	70	55	M10	G1/8	2.00
PLK45-2-4B	950	4	116	28	10	72	92	27.5	60	45	27.5	70	55	M10	G1/8	2.20
PLK45-2-6B	1,500	6	116	28	10	72	92	27.5	60	45	27.5	70	55	M10	G1/8	2.20
PLK55-1-4B	1,300	4	136	34	10	-	100	30.5	70	49	30.5	80	59	M10	G1/8	2.80
PLK55-1-6B	2,100	6	136	34	10	-	100	30.5	70	49	30.5	80	59	M10	G1/8	2.80
PLK55-2-4B	1,300	4	136	34	10	92	112	30.5	70	49	30.5	80	59	M10	G1/8	3.00
PLK55-2-6B	2,100	6	136	34	10	92	112	30.5	70	49	30.5	80	59	M10	G1/8	3.00

<sup>1</sup> The holding forces as shown in the capacity chart were determined on dry rails for roller systems (STAR, INA). Different holding forces may occur for other rails.

Issue 08.2016 – Specifications subject to change

## LOCKED SL Clamping Elements

### Combined clamping and braking

Always on the safe side: The safety clamping elements from the LOCKED series SL clamp and brake directly on the clear area of guide rails on linear modules with forces of up to 10,000 N. They are individually adjusted to the linear guide being used and are available for all rail sizes from 20 to 65 mm and profiles from all renowned manufacturers.

Special brake pads made of low wear sintered metal are used for the additional emergency stop braking functions in safety clamping elements from the LOCKED series SL. The SL series offer optimum static clamping with a service life up to 1 million cycles or up to 500 emergency braking operations. They also offer low system costs in comparison with hydraulic and electric solutions.

The LOCKED-Series SL is particularly used in machinery and special purpose machines.

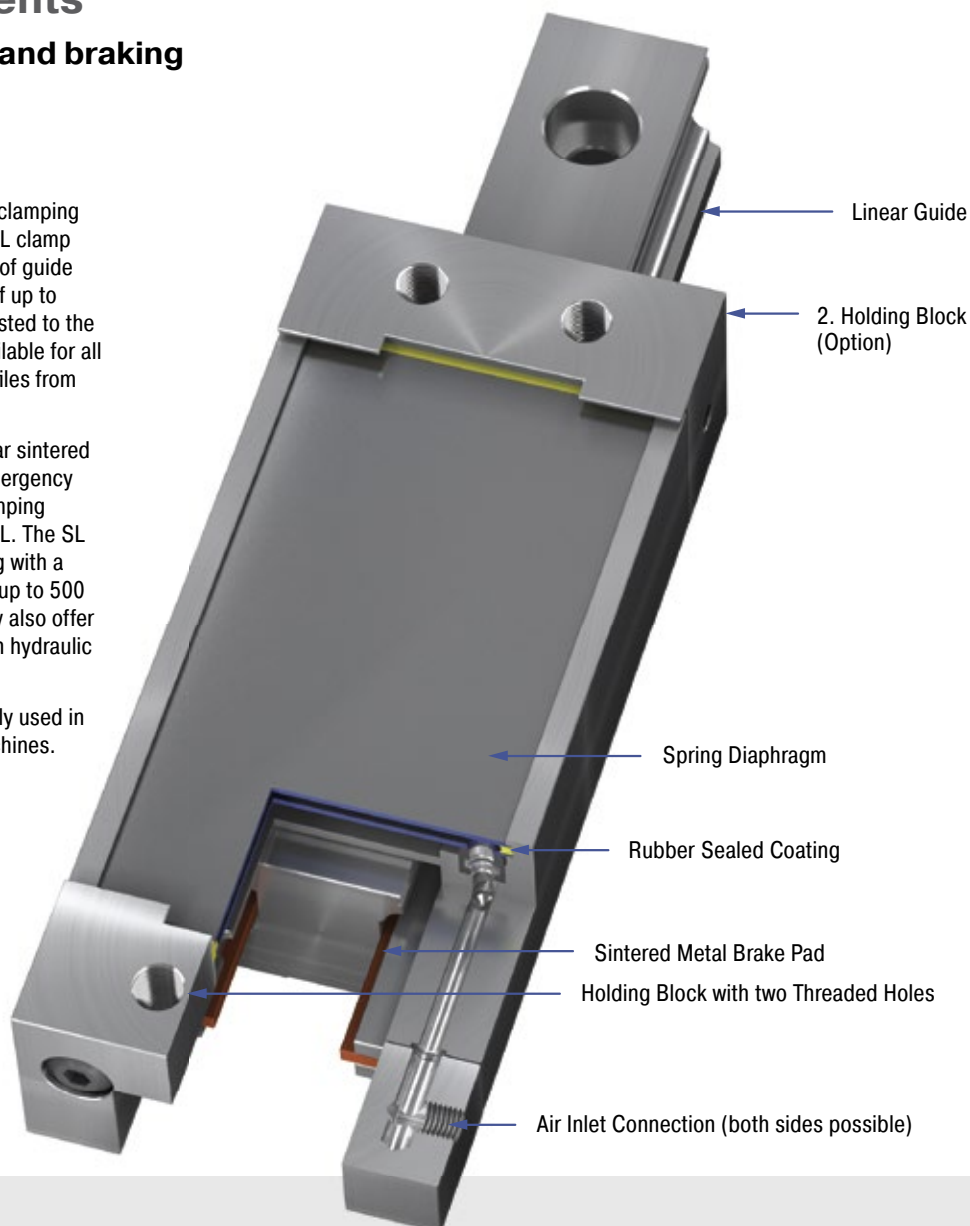

#### Technical Data

**Holding forces:** 540 N to 10,000 N

**Rail sizes:** 20 mm to 65 mm

**Clamping cycles/emergency use:**  
1,000,000/500

Higher values on request.

**Mounting:** In any position

**Operating pressure:** 4 bar (automotive)  
or 6 bar

**Material:** Outer body: Tool steel

**Pneumatic medium:** Dried, filtered air

**Operating temperature range:** 15 °C to  
45 °C

**Application field:** Tool machines, Transport systems, Feeder installations, Positioning tables

**Note:** If requested installation drawings of the respective types are provided.

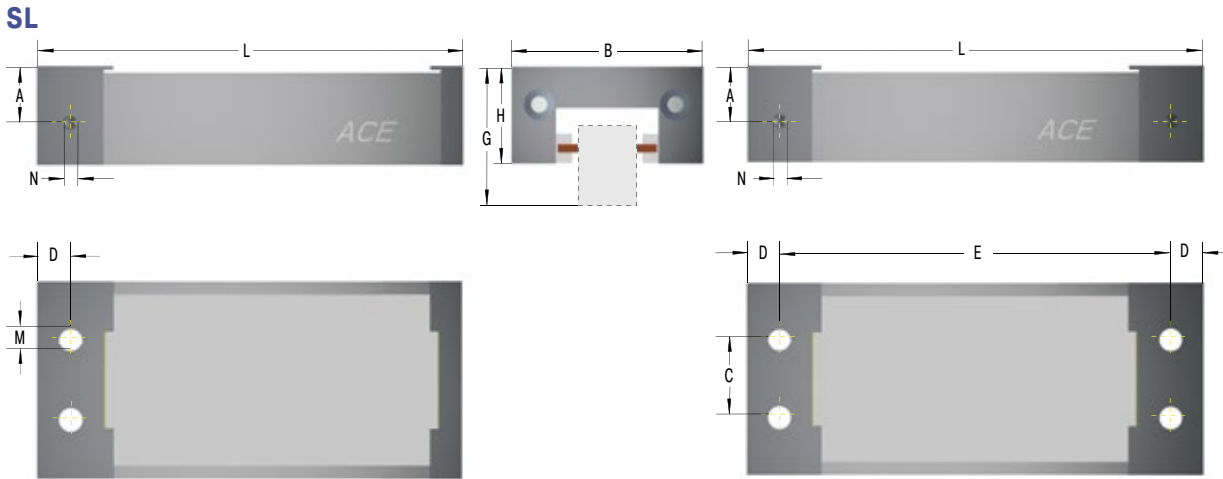

The calculation and selection of the most suitable clamping element should be carried out or be approved by ACE.

#### Complete details required when ordering

Operating pressure: 4 bar or 6 bar

#### Ordering Example

Linear Safety Clamping **SL55-1-4B-X**  
 Rail Nominal Size 55 mm  
 Number of Holding Blocks 1  
 4B = 4 bar Type  
 6B = 6 bar Type  
 Series Number assigned by ACE

#### Performance and Dimensions

TYPES	Holding force N	Operating pressure bar	B mm	C mm	D mm	E mm	L mm	Low Carriage			High Carriage			M	N	Weight kg
								A mm	G mm	H mm	A mm	G mm	H mm			
SL20-1-4B	540	4	43	12	6	-	97.5	13.5	30	19.5	-	-	-	M5	M5	0.32
SL20-1-6B	900	6	43	12	6	-	97.5	13.5	30	19.5	-	-	-	M5	M5	0.32
SL25-1-4B	780	4	47	16	6	-	117.5	15.5	36	25	19.5	40	29	M6	M5	0.50
SL25-1-6B	1,200	6	47	16	6	-	117.5	15.5	36	25	19.5	40	29	M6	M5	0.50
SL30-1-4B	1,100	4	59	18	10	-	126.5	17.0	42	29.5	20.0	45	32.5	M8	M5	0.90
SL30-1-6B	1,800	6	59	18	10	-	126.5	17.0	42	29.5	20.0	45	32.5	M8	M5	0.90
SL35-1-4B	1,800	4	69	22	10	-	156.5	22.5	48	35	29.5	55	42	M10	G1/8	1.26
SL35-1-6B	2,800	6	69	22	10	-	156.5	22.5	48	35	29.5	55	42	M10	G1/8	1.26
SL45-1-4B	2,400	4	80	28	10	-	176.5	26.5	60	42	36.5	70	52	M10	G1/8	2.30
SL45-1-6B	4,000	6	80	28	10	-	176.5	26.5	60	42	36.5	70	52	M10	G1/8	2.30
SL45-2-4B	2,400	4	80	28	10	171.2	191.5	26.5	60	42	36.5	70	52	M10	G1/8	2.30
SL45-2-6B	4,000	6	80	28	10	171.2	191.5	26.5	60	42	36.5	70	52	M10	G1/8	2.30
SL55-1-4B	3,600	4	98	34	12.5	-	202.5	28.0	70	49	38.0	80	59	M10	G1/8	3.90
SL55-1-6B	6,000	6	98	34	12.5	-	202.5	28.0	70	49	38.0	80	59	M10	G1/8	3.90
SL55-2-4B	3,600	4	98	34	12.5	196.2	221.5	28.0	70	49	38.0	80	59	M10	G1/8	3.90
SL55-2-6B	6,000	6	98	34	12.5	196.2	221.5	28.0	70	49	38.0	80	59	M10	G1/8	3.90
SL65-1-4B	6,000	4	120	44	15	-	259.5	38.0	90	64	48.0	100	74	M12	G1/8	5.00
SL65-1-6B	10,000	6	120	44	15	-	259.5	38.0	90	64	48.0	100	74	M12	G1/8	5.00
SL65-2-4B	6,000	4	120	44	15	251.2	281.5	38.0	90	64	48.0	100	74	M12	G1/8	5.20
SL65-2-6B	10,000	6	120	44	15	251.2	281.5	38.0	90	64	48.0	100	74	M12	G1/8	5.20

<sup>1</sup> The holding forces as shown in the capacity chart were determined on dry rails for roller systems (STAR, INA). Different holding forces may occur for other rails.

Issue 08.2016 – Specifications subject to change

## LOCKED SLK Clamping Elements

### Combined compact design clamping and braking

Small can clamp perfectly too: The LOCKED-Series SLK clamping elements are more compact than the Series SL. They also clamp directly onto the respective linear guide, suit all standard rail sizes from 15 to 55 mm and profiles from the known suppliers and are extremely reliable and safe.

Thanks to the patented spring steel plate system, the Series SLK achieves clamping and holding forces of up to 2,100 N with the shortest reaction times when vented. Thanks to the sintered metal coatings and the clamping function in emergency stop (e.g. in case of a power failure), this range enables braking directly on the rail. All clamping elements offer the maximum holding and braking forces and achieve up to 1 million clamping cycles or up to a maximum of 500 emergency braking operations in the 4 and 6 bar version.

The LOCKED-Series SLK are used in mechanical engineering and customised mechanical engineering.

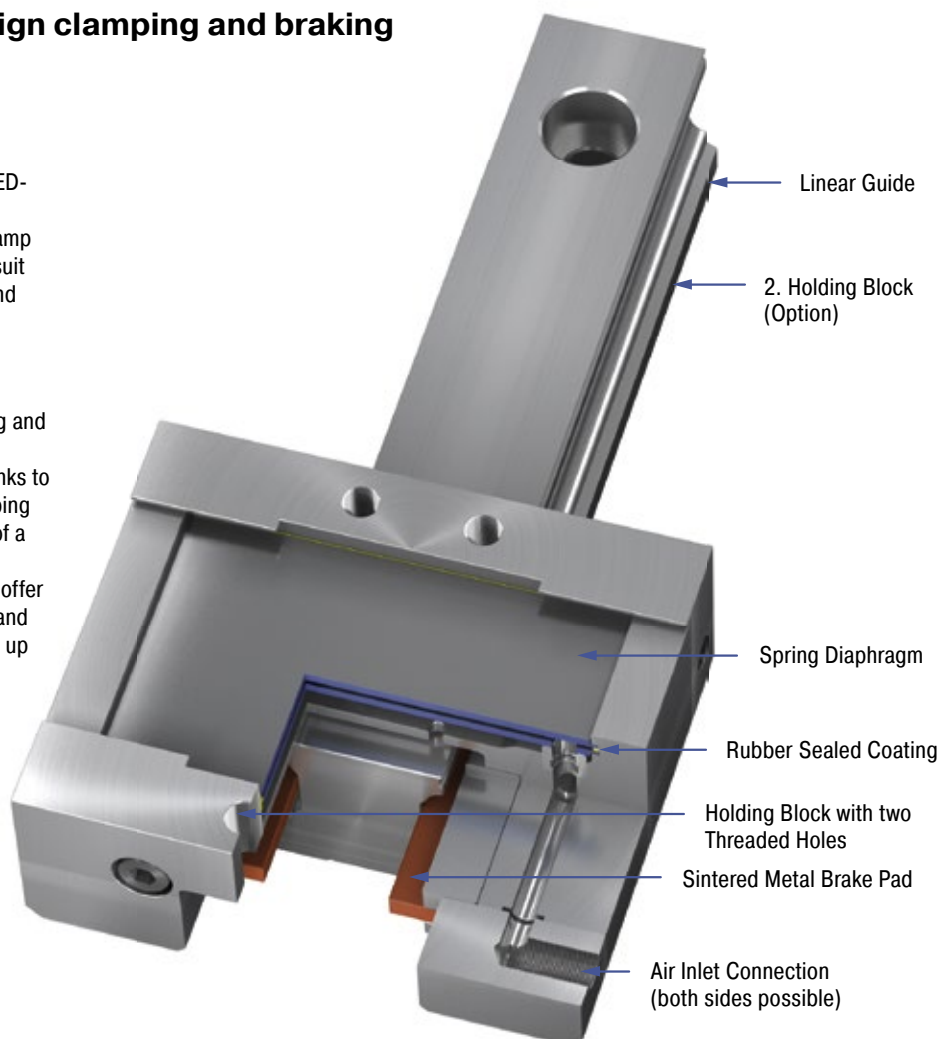

### Technical Data

**Holding forces:** 300 N to 2,100 N

**Rail sizes:** 15 mm to 55 mm

**Clamping cycles/emergency use:** 1,000,000/500. Higher values on request.

**Mounting:** In any position

**Operating pressure:** 4 bar (automotive) or 6 bar

**Material:** Outer body: Tool steel

**Pneumatic medium:** Dried, filtered air

**Operating temperature range:** 15 °C to 45 °C

**Application field:** Tool machines, Transport systems, Feeder installations, Positioning tables

**Note:** If requested installation drawings of the respective types are provided.

**On request:** Special designs on request.

### SLK

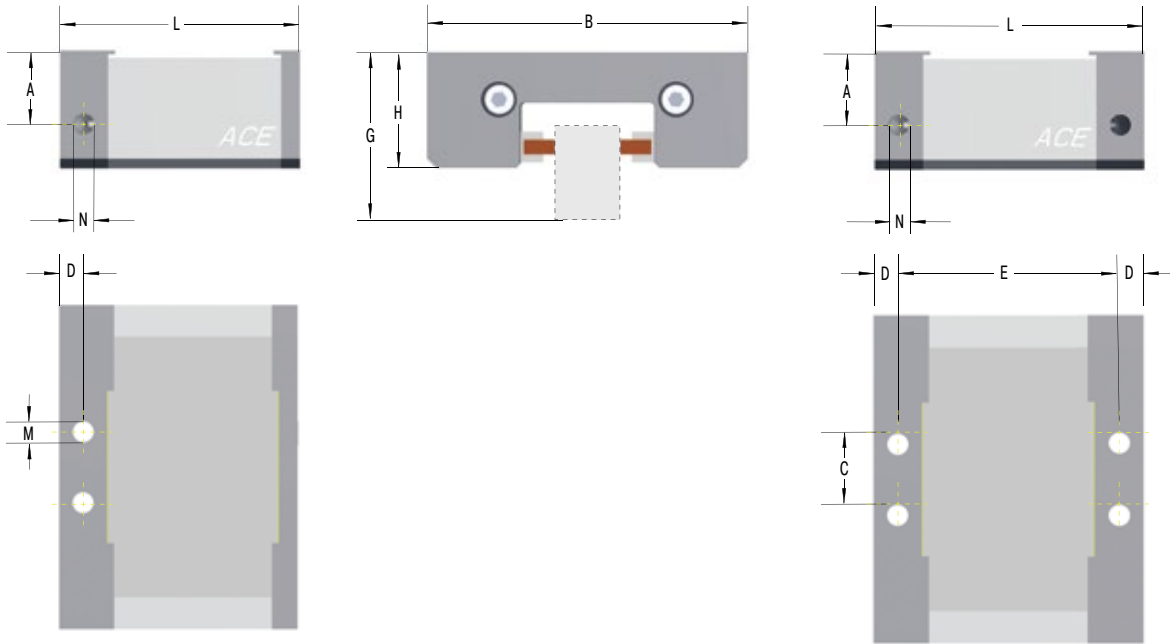

The calculation and selection of the most suitable clamping element should be carried out or be approved by ACE.

### Complete details required when ordering

Operating pressure: 4 bar or 6 bar

### Ordering Example

**SLK45-1-4B-X**

Linear Safety Clamping Compact \_\_\_\_\_  
 Rail Nominal Size 45 mm \_\_\_\_\_  
 Number of Holding Blocks 1 \_\_\_\_\_  
 4B = 4 bar Type \_\_\_\_\_  
 6B = 6 bar Type \_\_\_\_\_  
 Series Number assigned by ACE \_\_\_\_\_

### Performance and Dimensions

TYPES	Holding force N	Operating pressure bar	Low Carriage					High Carriage			M	N	Weight kg			
			B mm	C mm	D mm	E mm	L mm	A mm	G mm	H mm						
SLK15-1-4B	300	4	45	12	5	-	55.5	14.0	24	18	14.0	-	-	M5	M5	0.50
SLK15-1-6B	450	6	45	12	5	-	55.5	14.0	24	18	14.0	-	-	M5	M5	0.50
SLK20-1-4B	430	4	54	16	5	-	55.5	16.0	30	22	16.0	-	-	M6	M5	0.60
SLK20-1-6B	650	6	54	16	5	-	55.5	16.0	30	22	16.0	-	-	M6	M5	0.60
SLK25-1-4B	530	4	75	16	5	-	55.5	16.0	36	25.5	16.0	40	29.5	M6	M5	0.70
SLK25-1-6B	800	6	75	16	5	-	55.5	16.0	36	25.5	16.0	40	29.5	M6	M5	0.70
SLK30-1-4B	750	4	82	18	8.75	-	67	21.0	42	30	21.0	45	33	M8	M5	0.90
SLK30-1-6B	1,150	6	82	18	8.75	-	67	21.0	42	30	21.0	45	33	M8	M5	0.90
SLK35-1-4B	820	4	96	22	8.75	-	67	21.2	48	35	21.2	55	42	M10	G1/8	1.27
SLK35-1-6B	1,250	6	96	22	8.75	-	67	21.2	48	35	21.2	55	42	M10	G1/8	1.27
SLK45-1-4B	950	4	116	28	10	-	80	27.5	60	45	27.5	70	55	M10	G1/8	2.00
SLK45-1-6B	1,500	6	116	28	10	-	80	27.5	60	45	27.5	70	55	M10	G1/8	2.00
SLK45-2-4B	950	4	116	28	10	72	92	27.5	60	45	27.5	70	55	M10	G1/8	2.20
SLK45-2-6B	1,500	6	116	28	10	72	92	27.5	60	45	27.5	70	55	M10	G1/8	2.20
SLK55-1-4B	1,300	4	136	34	10	-	100	30.5	70	49	30.5	80	59	M10	G1/8	2.80
SLK55-1-6B	2,100	6	136	34	10	-	100	30.5	70	49	30.5	80	59	M10	G1/8	2.80
SLK55-2-4B	1,300	4	136	34	10	92	112	30.5	70	49	30.5	80	59	M10	G1/8	3.00
SLK55-2-6B	2,100	6	136	34	10	92	112	30.5	70	49	30.5	80	59	M10	G1/8	3.00

<sup>1</sup> The holding forces as shown in the capacity chart were determined on dry rails for roller systems (STAR, INA). Different holding forces may occur for other rails.



## LOCKED LZ-P Clamping Elements

### Certified safety clamping

Innovative and BG certified: The pneumatic clamping elements from the LOCKED-Series LZ-P have been specially designed for safe, reliable clamping on the vertical or Z-axes. The wedge principle makes sure that the gravity loaded axis does not drop. The brake wedges are pushed on both sides against the flat parallel surfaces of the guide rail in case of a loss of pressure.

Initially developed for Bosch-Rexroth rails in sizes 15 and 25 mm, a test certificate from the trade association was awarded after extensive tests on these clamping elements. Further certifications from other rail manufacturers and sizes are prepared and can be implemented within the shortest time. Users achieve holding forces of up to 2,500 N.

Pneumatic clamping elements from the LOCKED-Series LZ-P are used in all sectors of modern mechanical engineering and customised machine tools.

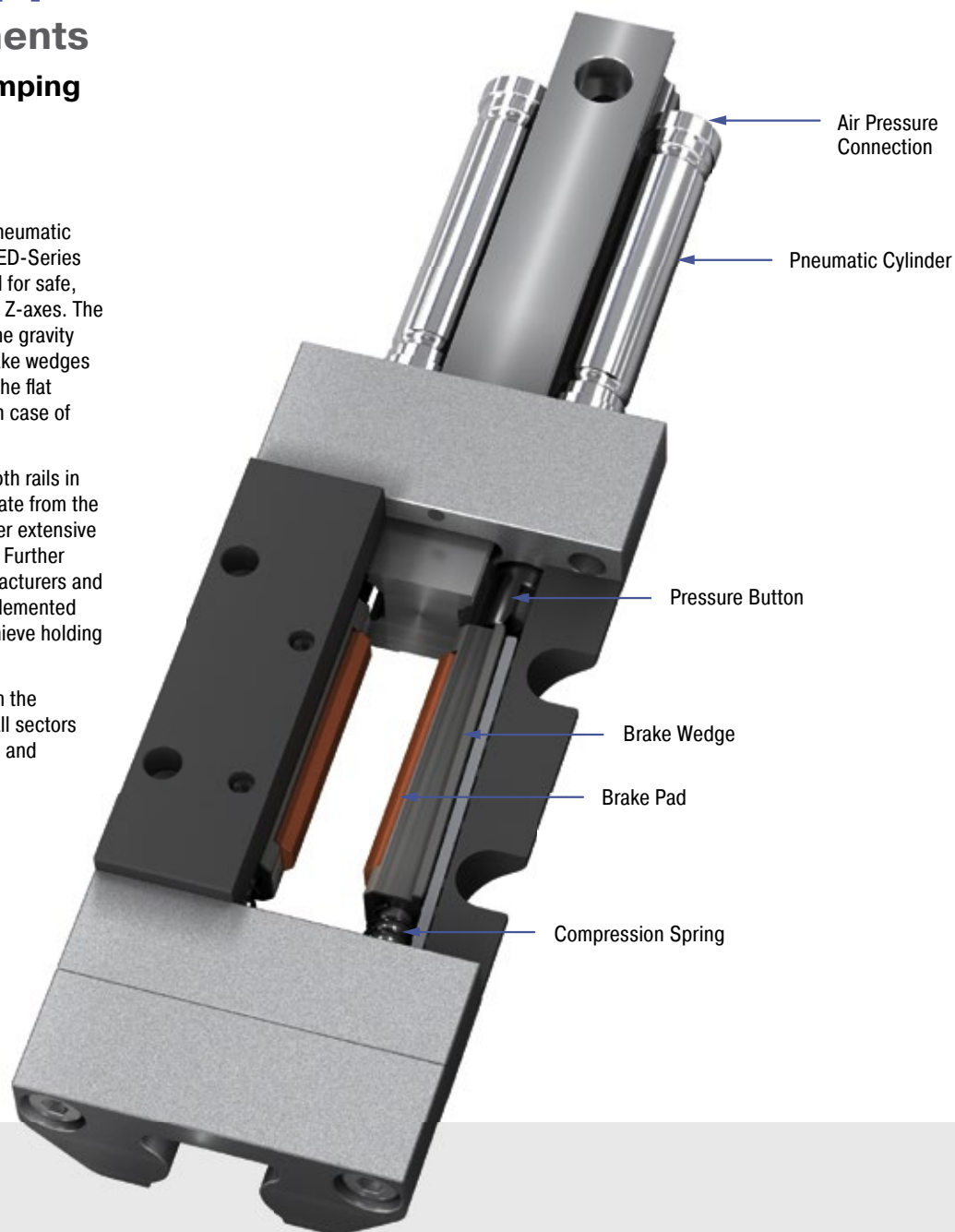

### Technical Data

**Holding forces:** 1,500 N to 2,500 N

**Rail sizes:** 15 mm and 25 mm Bosch Rexroth

**Clamping cycles:** 1,000,000

**Mounting:** Vertical

**Effective direction:** Z-axes toward gravity

**Operating pressure:** 4.8 bar to 8 bar

**Material:** Outer body: Tool steel; Brake components: Steel

**Pneumatic medium:** Dried, filtered air

**Operating temperature range:** 0 °C to 60 °C

**Application field:** Z-axes, Vertical conveyor systems, Jacking applications



#### LZ-P

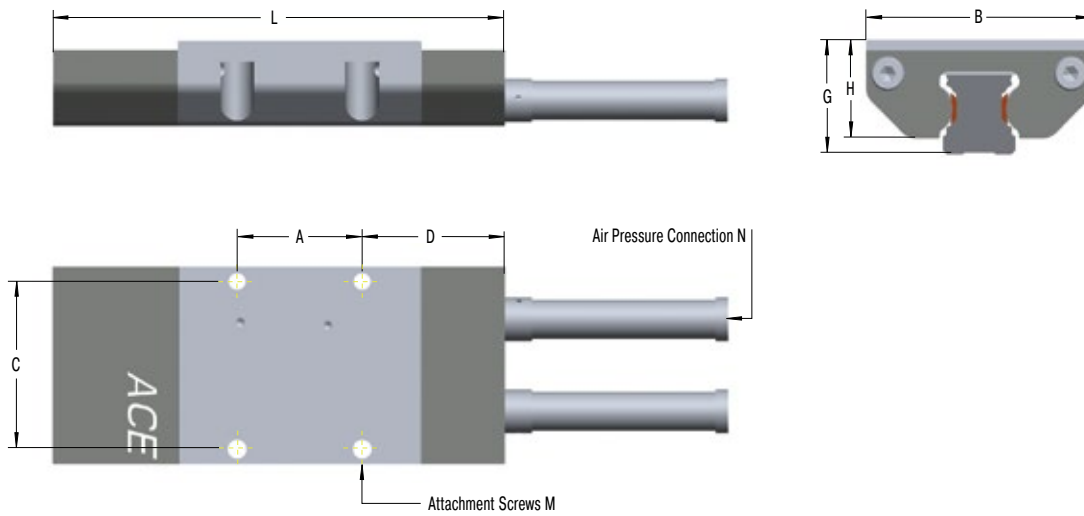

The calculation and selection of the most suitable clamping element should be carried out or be approved by ACE.

#### Ordering Example

Process Clamping Z-Axis \_\_\_\_\_ **LZ-P15-X**  
 Rail Nominal Size 15 mm \_\_\_\_\_  
 Series Number assigned by ACE \_\_\_\_\_

#### Performance and Dimensions

TYPES	Holding force <b>N</b>	A <b>mm</b>	B <b>mm</b>	C <b>mm</b>	D <b>mm</b>	G <b>mm</b>	H <b>mm</b>	L <b>mm</b>	M	N	Weight <b>kg</b>
LZ-P15-X	1,500	30	47	40	34	24	20	108.5	M4	M3	0.4
LZ-P25-X	2,500	30	70	56	70	36	30	170.0	M6	M5	1.3

## LOCKED PN Clamping Elements

### Rod clamping with maximum clamping force

Immediate clamping in case of loss of pneumatics: Suitable for rods with diameters of 20 to 40 mm, the clamping elements from the LOCKED-Series PN absorb the forces axially and rotationally. With holding forces of up to 36,000 N, they reach or exceed the levels of hydraulic clamps. The system costs are however lower.

Alongside clamping in both directions of motion, the LOCKED-PN also surprises with its compact design. They need less installation space and enable short rod lengths. For versions with ISO pneumatic cylinders, the base plate is coordinated to the dimensions of the flange sizes of standard cylinders according to ISO 15552. Users appreciate the modular system. It allows several segments to be stacked so that the necessary clamping force can be attained for every application.

The areas of application for the LOCKED-Series PN are mechanical engineering and machine tools.

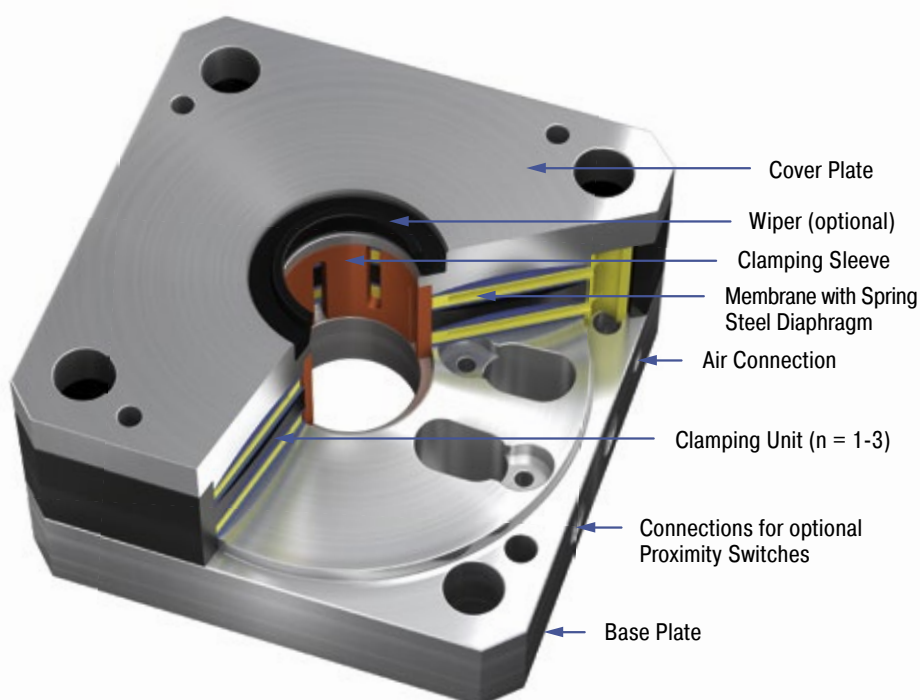

### Technical Data

**Holding torques:** 15 Nm to 720 Nm

**Holding forces:** 1,400 N to 36,000 N

**Rod diameter:** Ø 20 mm to Ø 40 mm

**Clamping cycles:** 1,000,000. Higher values on request.

**Mounting:** In any position

**Operating pressure:** 4 bar (automotive) or 6 bar

**Material:** Outer body: Tool steel

**Pneumatic medium:** Dried, filtered air

**Operating temperature range:** 10 °C to 45 °C

**Application field:** Jacking systems, Light presses, Punching/stamping machines, Stacking units

**Note:** When mounting, use hardened piston rod.

**On request:** Special designs as for example special diameters and accessories available on request.

#### PN

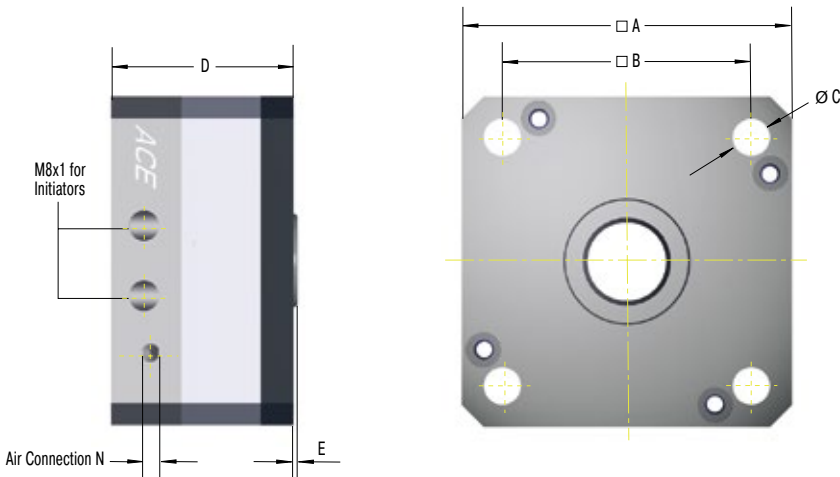

The calculation and selection of the most suitable clamping element should be carried out or be approved by ACE.

#### Ordering Example

Rod Clamping Standard Model \_\_\_\_\_  
 Cylinder Nominal Diameter 80 mm \_\_\_\_\_  
 Rod Diameter 25 mm \_\_\_\_\_  
 Number of Clamping Units 3 \_\_\_\_\_  
 6B = 6 bar Type \_\_\_\_\_  
 4B = 4 bar Type \_\_\_\_\_

**PN80-25-3-4B**

#### Performance and Dimensions

TYPES	<sup>1</sup> Holding force N	Holding torque Nm	Operating pressure bar	A mm	B mm	C mm	D mm	E mm	N	Weight kg
PN63-20-1-4B	1,400	15	4	75	56.5	8.5	41.5	2.1	M5	0.70
PN63-20-1-6B	2,000	20	6	75	56.5	8.5	41.5	2.1	M5	0.70
PN63-20-2-4B	2,520	25	4	75	56.5	8.5	59.5	2.1	M5	1.13
PN63-20-2-6B	3,600	35	6	75	56.5	8.5	59.5	2.1	M5	1.13
PN63-20-3-4B	3,780	35	4	75	56.5	8.5	77.5	2.1	M5	1.56
PN63-20-3-6B	5,400	50	6	75	56.5	8.5	77.5	2.1	M5	1.56
PN80-25-1-4B	2,100	25	4	96	72	10.5	43.5	2.14	G1/8	1.30
PN80-25-1-6B	3,000	35	6	96	72	10.5	43.5	2.14	G1/8	1.30
PN80-25-2-4B	3,780	40	4	96	72	10.5	63.5	2.14	G1/8	2.20
PN80-25-2-6B	5,400	60	6	96	72	10.5	63.5	2.14	G1/8	2.20
PN80-25-3-4B	5,670	65	4	96	72	10.5	83.5	2.14	G1/8	3.10
PN80-25-3-6B	8,100	95	6	96	72	10.5	83.5	2.14	G1/8	3.10
PN125-40-1-4B	7,000	140	4	145	110	13	51.6	3	G1/8	3.65
PN125-40-1-6B	10,000	200	6	145	110	13	51.6	3	G1/8	3.65
PN125-40-2-4B	12,600	250	4	145	110	13	75.2	3	G1/8	5.85
PN125-40-2-6B	18,000	360	6	145	110	13	75.2	3	G1/8	5.85
PN125-40-3-4B	18,900	375	4	145	110	13	98.8	3	G1/8	8.05
PN125-40-3-6B	27,000	540	6	145	110	13	98.8	3	G1/8	8.05
PN125-40-4-4B	25,200	500	4	145	110	13	122.4	3	G1/8	10.25
PN125-40-4-6B	36,000	720	6	145	110	13	122.4	3	G1/8	10.25

<sup>1</sup> The listed holding forces are reached under optimum conditions. We recommend a safety factor of > 10 %. Please note that surface, material and cleanliness of the rod as well as wear and tear and the use of rod wipers lead to different holding forces. Test the clamping needed for series production or safety applications in its specific application environment and measure the actual values.

## LOCKED PRK Clamping Elements

### Rod clamping with maximum clamping force in a compact size

Compact and safe: when space becomes restricted, the compact clamping elements from the LOCKED-Series PRK come into their own. As pneumatic rod clamping with low heights of 28 to 34 mm, they provide clamping forces of up to 5,000 N.

Clamping is carried out by a diaphragm spring-plate system and is released when compressed air is applied. Clamping elements from the LOCKED-Series PRK absorb the forces on rods with diameters between 20 and 40 mm both axially and rotationally. The function makes them suitable for use as static clamping without pressure, because the failure or drop of pneumatic pressure triggers immediate clamping. High clamping forces with low system costs compared with hydraulic and electric solutions make these clamping elements particularly interesting.

Models from the LOCKED-Series PRK are used in mechanical engineering and customised machine tools.

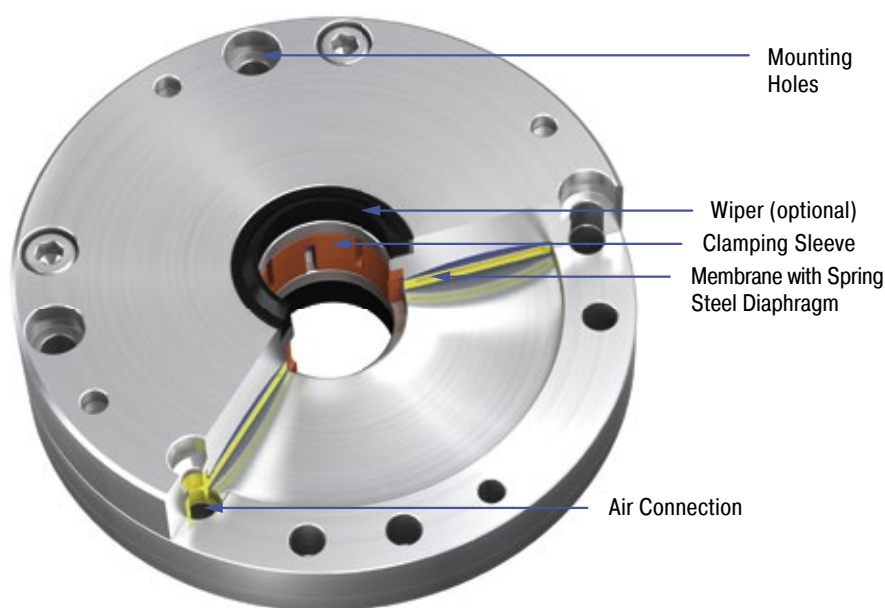

#### Technical Data

**Holding torques:** 7 Nm to 100 Nm

**Holding forces:** 700 N to 5,000 N

**Rod diameter:** Ø 20 mm to Ø 40 mm

**Clamping cycles:** 1,000,000. Higher values on request.

**Mounting:** In any position

**Operating pressure:** 4 bar (automotive) or 6 bar

**Material:** Outer body: Tool steel

**Pneumatic medium:** Dried, filtered air

**Operating temperature range:** 10 °C to 45 °C

**Application field:** Jacking systems, Light presses, Punching/stamping machines, Stacking units

**Note:** When mounting, use hardened piston rod.

**On request:** Special designs as for example special diameters and accessories available on request.

### PRK

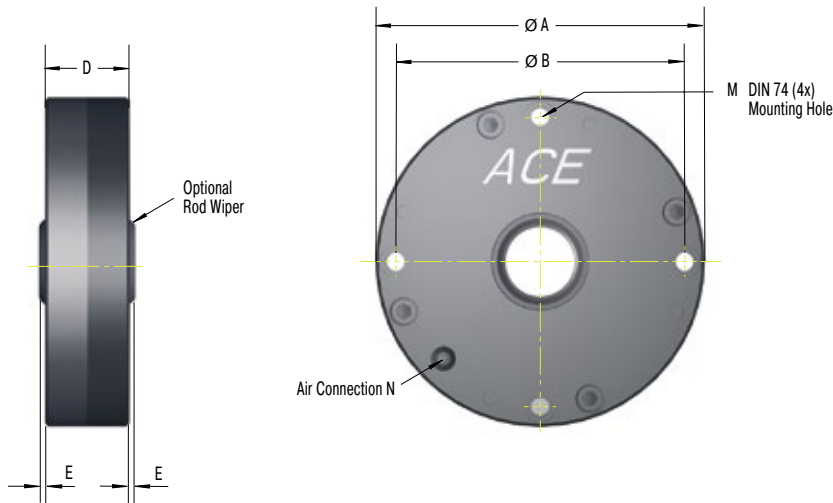

The calculation and selection of the most suitable clamping element should be carried out or be approved by ACE.

### Complete details required when ordering

Operating pressure: 4 bar or 6 bar

### Ordering Example

Rod Clamping Compact \_\_\_\_\_ **PRK80-25-6B**  
 Cylinder Nominal Diameter 80 mm \_\_\_\_\_  
 Rod Diameter 25 mm \_\_\_\_\_  
 6B = 6 bar Type \_\_\_\_\_  
 4B = 4 bar Type \_\_\_\_\_

### Performance and Dimensions

TYPES	<sup>1</sup> Holding force <b>N</b>	Holding torque <b>Nm</b>	Operating pressure <b>bar</b>	A <b>mm</b>	B <b>mm</b>	D <b>mm</b>	E <b>mm</b>	M	N	Weight <b>kg</b>
PRK63-20-4B	700	7	4	92	80	28	2.1	M5	G1/8	1.15
PRK63-20-6B	1,000	10	6	92	80	28	2.1	M5	G1/8	1.15
PRK80-25-4B	1,050	12	4	118	104	29	2.14	M6	G1/8	2.10
PRK80-25-6B	1,500	17	6	118	104	29	2.14	M6	G1/8	2.10
PRK125-40-4B	3,500	70	4	168	152	29	3	M6	G1/8	4.90
PRK125-40-6B	5,000	100	6	168	152	29	3	M6	G1/8	4.90

<sup>1</sup> The listed holding forces are reached under optimum conditions. We recommend a safety factor of > 10 %. Please note that surface, material and cleanliness of the rod as well as wear and tear and the use of rod wipers lead to different holding forces. Test the clamping needed for series production or safety applications in its specific application environment and measure the actual values.

## LOCKED R Clamping Elements

### Strong holding force on the shaft

Direct clamping on the shaft: Rotation motions are prevented by the LOCKED-Series R. Their clamping elements are available for shaft diameters of 50 to 340 mm and ensure maximum holding forces.

The clamp is immediately applied by the diaphragm and spring-plate system when pressure is lost. Pneumatic quick-switch valves reduce the reaction times. The costs are low in comparison with hydraulic clamping systems. Their performance is, however, achieved or exceeded despite the compact and easy to assemble design. Special versions for YRT bearings as well as active clamping elements are additionally available. ACE recommends the use of the optional shaft flange as wear protection. The clamping force can be increased considerably by the use of the additional air function.

Models from the LOCKED-Series R are also used in mechanical engineering and customised machine tools.

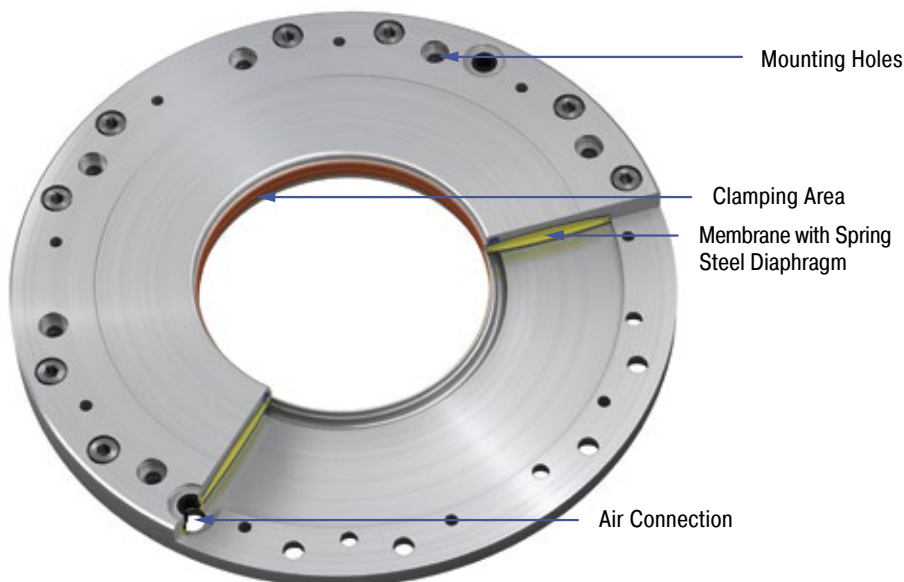

### Technical Data

**Holding torques:** 42 Nm to 4,680 Nm

**Shaft diameter:** Ø 50 mm to Ø 340 mm

**Clamping cycles:** 1,000,000. Higher values on request.

**Mounting:** In any position

**Operating pressure:** 4 bar (automotive) or 6 bar

**Material:** Outer body: Hardened fine-grain structural steel, inner bore ground

**Pneumatic medium:** Dried, filtered air

**Operating temperature range:** 10 °C to 45 °C

**Application field:** Drive shafts, Torque motors, Conveyor systems

**Note:** If requested installation drawings of the respective types are provided.

**On request:** Special designs and customised solutions e.g. YRT bearing up to Ø 460 mm and shaft flange available on request.

R

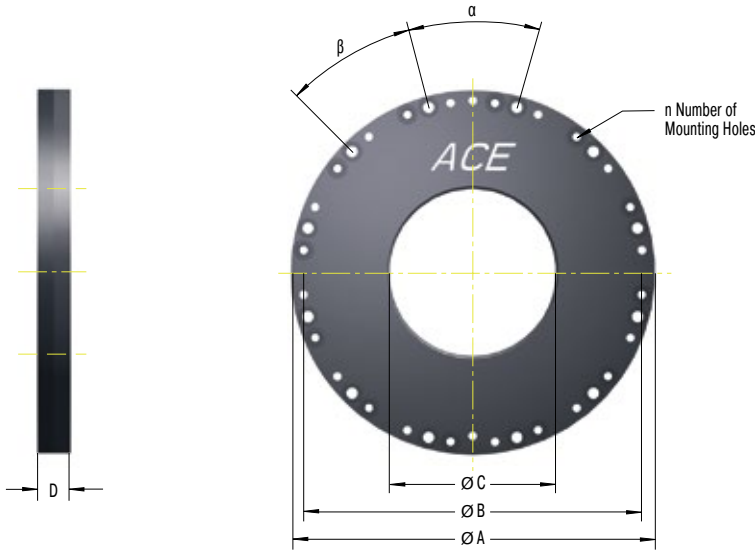

The calculation and selection of the most suitable clamping element should be carried out or be approved by ACE.

#### Complete details required when ordering

Operating pressure: 4 bar or 6 bar  
Option: With additional air

#### Ordering Example

Rotational Clamping R80-Z-6B  
 Shaft Nominal Diameter 80 mm  
 Z = Increased Force with Additional Air  
 6B = 6 bar Type  
 4B = 4 bar Type

#### Performance and Dimensions

TYPES	Holding torque Nm	Operating pressure bar	A mm	B mm	C opened mm	Shaft Diameter mm	D mm	n	$\alpha$ °	$\beta$ °	Weight kg
R50-4B	42	4	145	134	50+0.03/+0.05	50-0.01/-0.025	15	8	45	45	1.7
R50-6B	60	6	145	134	50+0.03/+0.05	50-0.01/-0.025	15	8	45	45	1.7
R60-4B	59	4	155	144	60+0.03/+0.05	60-0.01/-0.025	15	8	45	45	1.9
R60-6B	84	6	155	144	60+0.03/+0.05	60-0.01/-0.025	15	8	45	45	1.9
R70-4B	80	4	165	154	70+0.03/+0.05	70-0.01/-0.025	15	12	30	30	2.1
R70-6B	114	6	165	154	70+0.03/+0.05	70-0.01/-0.025	15	12	30	30	2.1
R80-4B	105	4	175	164	80+0.03/+0.05	80-0.01/-0.025	15	12	30	30	2.3
R80-6B	150	6	175	164	80+0.03/+0.05	80-0.01/-0.025	15	12	30	30	2.3
R90-4B	132	4	185	174	90+0.03/+0.05	90-0.01/-0.025	15	12	30	30	2.5
R90-6B	189	6	185	174	90+0.03/+0.05	90-0.01/-0.025	15	12	30	30	2.5
R100-4B	168	4	228	210	100+0.04/+0.06	100-0.01/-0.025	16	12	40	20	4.1
R100-6B	240	6	228	210	100+0.04/+0.06	100-0.01/-0.025	16	12	40	20	4.1
R120-4B	235	4	248	230	120+0.04/+0.06	120-0.01/-0.025	16	12	40	20	4.6
R120-6B	336	6	248	230	120+0.04/+0.06	120-0.01/-0.025	16	12	40	20	4.6
R140-4B	319	4	268	250	140+0.04/+0.06	140-0.01/-0.025	16	12	40	20	5.1
R140-6B	456	6	268	250	140+0.04/+0.06	140-0.01/-0.025	16	12	40	20	5.1
R160-4B	420	4	288	270	160+0.04/+0.06	160-0.01/-0.025	16	12	40	20	5.6
R160-6B	600	6	288	270	160+0.04/+0.06	160-0.01/-0.025	16	12	40	20	5.6
R180-4B	525	4	308	290	180+0.04/+0.06	180-0.01/-0.025	20	16	30	15	7.7
R180-6B	750	6	308	290	180+0.04/+0.06	180-0.01/-0.025	20	16	30	15	7.7
R200-4B	651	4	328	310	200+0.05/+0.07	200-0.01/-0.03	20	16	30	15	8.3
R200-6B	930	6	328	310	200+0.05/+0.07	200-0.01/-0.03	20	16	30	15	8.3
R220-4B	777	4	348	330	220+0.05/+0.07	220-0.01/-0.03	20	16	30	15	8.9
R220-6B	1,110	6	348	330	220+0.05/+0.07	220-0.01/-0.03	20	16	30	15	8.9
R240-4B	945	4	368	350	240+0.05/+0.07	240-0.01/-0.03	20	24	20	10	9.5
R240-6B	1,350	6	368	350	240+0.05/+0.07	240-0.01/-0.03	20	24	20	10	9.5
R260-4B	1,092	4	388	370	260+0.05/+0.07	260-0.01/-0.03	22	24	20	10	11.2
R260-6B	1,560	6	388	370	260+0.05/+0.07	260-0.01/-0.03	22	24	20	10	11.2
R280-4B	1,260	4	408	390	280+0.05/+0.07	280-0.01/-0.03	22	24	20	10	11.9
R280-6B	1,800	6	408	390	280+0.05/+0.07	280-0.01/-0.03	22	24	20	10	11.9
R300-4B	1,470	4	428	410	300+0.05/+0.07	300-0.01/-0.03	22	24	20	10	12.6
R300-6B	2,100	6	428	410	300+0.05/+0.07	300-0.01/-0.03	22	24	20	10	12.6
R320-4B	1,638	4	448	430	320+0.05/+0.07	320-0.01/-0.03	22	24	20	10	13.1
R320-6B	2,340	6	448	430	320+0.05/+0.07	320-0.01/-0.03	22	24	20	10	13.1
R340-4B	1,806	4	468	450	340+0.05/+0.07	340-0.01/-0.03	22	24	20	10	14.0
R340-6B	2,580	6	468	450	340+0.05/+0.07	340-0.01/-0.03	22	24	20	10	14.0

Issue 08.2016 – Specifications subject to change



Pneumatic Rotational Clamping

R-Z

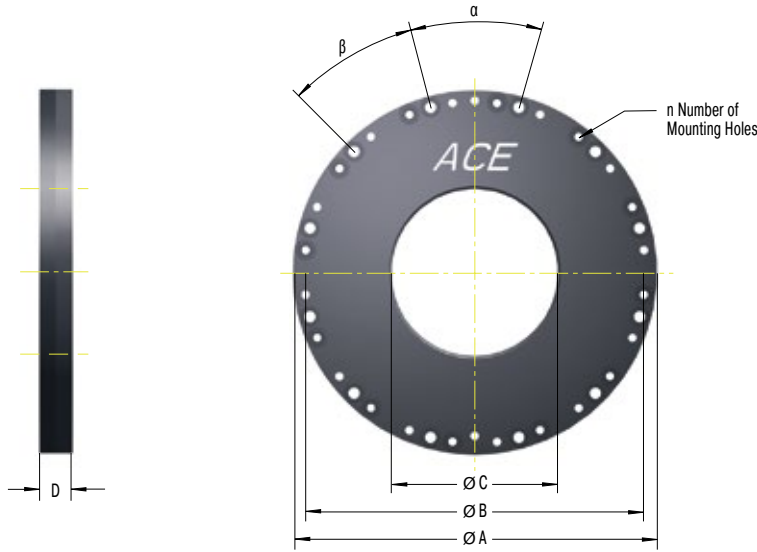

The calculation and selection of the most suitable clamping element should be carried out or be approved by ACE.

Complete details required when ordering

Operating pressure: 4 bar or 6 bar  
Option: With additional air

Ordering Example

Rotational Clamping R80-Z-6B  
 Shaft Nominal Diameter 80 mm  
 Z = Increased Force with Additional Air  
 6B = 6 bar Type  
 4B = 4 bar Type

Performance and Dimensions

TYPES	Holding torque Nm	Operating pressure bar	A mm	B mm	C opened mm	Shaft Diameter mm	D mm	n	$\alpha$ °	$\beta$ °	Weight kg
R50-Z-4B	76	4	145	134	50+0.03/+0.05	50-0.01/-0.025	15	8	45	45	1.7
R50-Z-6B	108	6	145	134	50+0.03/+0.05	50-0.01/-0.025	15	8	45	45	1.7
R60-Z-4B	107	4	155	144	60+0.03/+0.05	60-0.01/-0.025	15	8	45	45	1.9
R60-Z-6B	153	6	155	144	60+0.03/+0.05	60-0.01/-0.025	15	8	45	45	1.9
R70-Z-4B	147	4	165	154	70+0.03/+0.05	70-0.01/-0.025	15	12	30	30	2.1
R70-Z-6B	210	6	165	154	70+0.03/+0.05	70-0.01/-0.025	15	12	30	30	2.1
R80-Z-4B	189	4	175	164	80+0.03/+0.05	80-0.01/-0.025	15	12	30	30	2.3
R80-Z-6B	270	6	175	164	80+0.03/+0.05	80-0.01/-0.025	15	12	30	30	2.3
R90-Z-4B	239	4	185	174	90+0.03/+0.05	90-0.01/-0.025	15	12	30	30	2.5
R90-Z-6B	342	6	185	174	90+0.03/+0.05	90-0.01/-0.025	15	12	30	30	2.5
R100-Z-4B	294	4	228	210	100+0.04/+0.06	100-0.01/-0.025	16	12	40	20	4.1
R100-Z-6B	420	6	228	210	100+0.04/+0.06	100-0.01/-0.025	16	12	40	20	4.1
R120-Z-4B	420	4	248	230	120+0.04/+0.06	120-0.01/-0.025	16	12	40	20	4.6
R120-Z-6B	600	6	248	230	120+0.04/+0.06	120-0.01/-0.025	16	12	40	20	4.6
R140-Z-4B	588	4	268	250	140+0.04/+0.06	140-0.01/-0.025	16	12	40	20	5.1
R140-Z-6B	840	6	268	250	140+0.04/+0.06	140-0.01/-0.025	16	12	40	20	5.1
R160-Z-4B	756	4	288	270	160+0.04/+0.06	160-0.01/-0.025	16	12	40	20	5.6
R160-Z-6B	1,080	6	288	270	160+0.04/+0.06	160-0.01/-0.025	16	12	40	20	5.6
R180-Z-4B	966	4	308	290	180+0.04/+0.06	180-0.01/-0.025	20	16	30	15	7.7
R180-Z-6B	1,380	6	308	290	180+0.04/+0.06	180-0.01/-0.025	20	16	30	15	7.7
R200-Z-4B	1,176	4	328	310	200+0.05/+0.07	200-0.01/-0.03	20	16	30	15	8.3
R200-Z-6B	1,680	6	328	310	200+0.05/+0.07	200-0.01/-0.03	20	16	30	15	8.3
R220-Z-4B	1,428	4	348	330	220+0.05/+0.07	220-0.01/-0.03	20	16	30	15	8.9
R220-Z-6B	2,040	6	348	330	220+0.05/+0.07	220-0.01/-0.03	20	16	30	15	8.9
R240-Z-4B	1,680	4	368	350	240+0.05/+0.07	240-0.01/-0.03	20	24	20	10	8.9
R240-Z-6B	2,400	6	368	350	240+0.05/+0.07	240-0.01/-0.03	20	24	20	10	8.9
R260-Z-4B	1,974	4	388	370	260+0.05/+0.07	260-0.01/-0.03	22	24	20	10	11.2
R260-Z-6B	2,820	6	388	370	260+0.05/+0.07	260-0.01/-0.03	22	24	20	10	11.2
R280-Z-4B	2,268	4	408	390	280+0.05/+0.07	280-0.01/-0.03	22	24	20	10	11.9
R280-Z-6B	3,240	6	408	390	280+0.05/+0.07	280-0.01/-0.03	22	24	20	10	11.9
R300-Z-4B	2,604	4	428	410	300+0.05/+0.07	300-0.01/-0.03	22	24	20	10	12.6
R300-Z-6B	3,720	6	428	410	300+0.05/+0.07	300-0.01/-0.03	22	24	20	10	12.6
R320-Z-4B	2,940	4	448	430	320+0.05/+0.07	320-0.01/-0.03	22	24	20	10	13.1
R320-Z-6B	4,200	6	448	430	320+0.05/+0.07	320-0.01/-0.03	22	24	20	10	13.1
R340-Z-4B	3,276	4	468	450	340+0.05/+0.07	340-0.01/-0.03	22	24	20	10	14.0
R340-Z-6B	4,680	6	468	450	340+0.05/+0.07	340-0.01/-0.03	22	24	20	10	14.0

## Application Examples

### SL Special LOCKED SL elements for emergency stops

In order to secure the processing position of a special lathe in both the horizontal and the vertical axis, ACE LOCKED elements of the type SL35-1-6B are installed. They have the further advantage of preventing slippage through the vertical axis in the case of a malfunction. The products used in the SL-series not only have the correct track width and offer very high process clamping forces of up to 10,000 N, but can also apply the same force as an emergency-stop braking function. This is due to the specially integrated brake linings made of low-wear sintered metal.

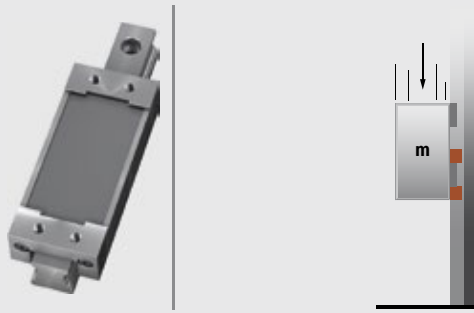

ACE clamping and safety elements maintain a rock-solid hold on the axes in special lathes and secure the predetermined positions both horizontally and vertically

RASOMA Werkzeugmaschinen GmbH, 04720 Döbeln, Germany

### SLK Secure rail clamping

ACE clamping elements secure machines in the tyre industry. The goods accumulator/compensator of a material dispenser carries meandering, coiled, highly tear resistant material strips, which are fed at high speed to a tyre-manufacturing machine. To prevent damaging the machine, innovative type SLK25-1-6B clamping elements are employed.



Secure material accumulator

## PN

## Clamping elements as a variable stop

ACE clamping elements are inserted, as a variable stop, during a joining process for the production of drilling tools. They meet the requirements for a precise positioning of the workpiece head and an adaptation of the length tolerance of up to 3 mm, ideally. ACE was awarded the contract because the clamping element is attached on a bar and its PN LOCKED series is specifically designed for this purpose. For clamping on linear guides, rails, axles and shafts, ACE offers a great range of high-performance models.

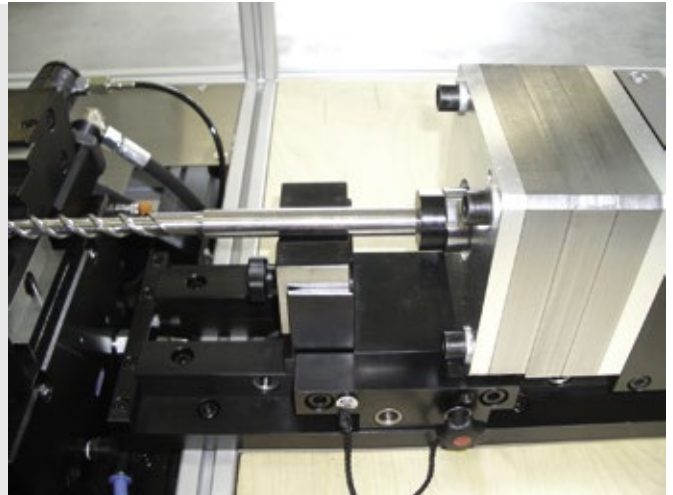
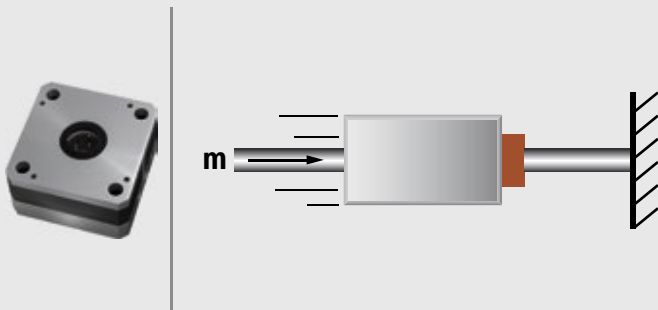

ACE clamping elements assist in the production of drilling tools: the LOCKED-P system clamps and at the same time absorbs the opposing forces of the joining process without difficulty  
GRAF automation GmbH, 88214 Ravensburg, Germany

## PN

## Secure rod clamping

Pneumatic rod clamping allows hydraulic presses to be used for any application. With the help of hydraulic presses, cut ceramic parts are manufactured during the week. So that the rods of the upper and lower stamping plate do not sag when the press is at a standstill over the weekend or during holidays and therefore have to be setup again on the next working day, PN80-25-2-6B type rod clamps are used.

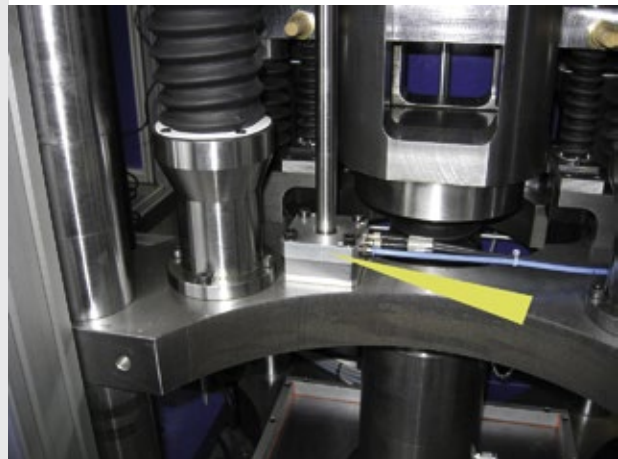

Secured Presses  
KOMAGE Gellner Maschinenfabrik KG, 54427 Kell am See, Germany